

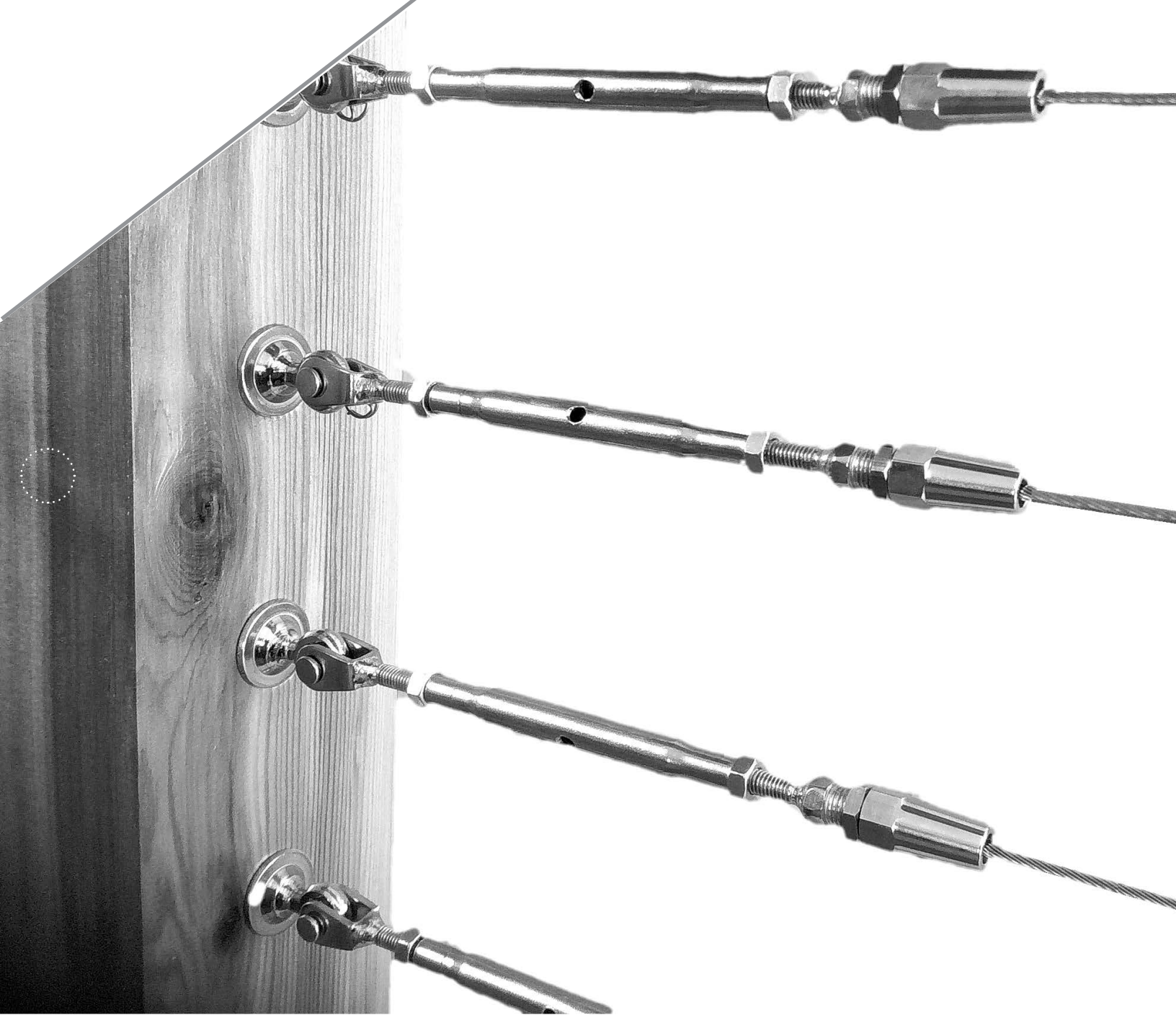

RAM TAIL

CABLE RAIL SYSTEMS



Product Catalog
www.ramtail.com
(251) 943 - 4675

TABLE OF CONTENTS



About Us.....	2
Tension End Fittings/Assemblies	3-5
Quick Lock Fittings	6
Fixed End Fittings.....	7
Stainless Steel Cable.....	8
Hardware & Installation Tools.....	9
Installation Instructions.....	10
Star Installation.....	11
FAQ.....	12
Product Reference Sheet.....	13



We work with architects, contractors and homeowners all over the country to provide you with one of our railing designs ready to install. Our design process ensures an attractive look and a layout that suits your needs.

If you have a home at a certain elevation, one thing you are always trying to protect is your spectacular view. You may be willing to cut down trees and negotiate with neighbors in order to take in the beautiful landscape, so why would you choose a railing system for your deck or balcony that obstructs your line of sight in any way? If you want a railing system for your home that will serve its purpose yet be practically invisible, you want a stainless cable railing system. Cable railings have emerged as a popular choice in recent years, for both homeowners and commercial property owners.

There is no simpler way to enhance the visual appeal of a deck, balcony or even a garden. Cable railings have long been used in commercial buildings, like hotels, malls, and airports because of their clear, understated design, low-maintenance, longstanding durability and affordability. For these reasons, homeowners are also incorporating cable railings into decking and other projects.

ASSEMBLIES

TURNBUCKLE / FORK JAW



EYE LAG
RT-EL-01

TURNBUCKLE
RT TB-01

FORK JAW
RT FJ-01

EYE LAG
RT-EL-01

**SQUARE EYE PLATE CAN BE USED IN PLACE OF EYE LAG

THRU-POST SYSTEM



CYLINDRICAL TENSIONER
RT CT-75 / 115

THREADED JAWS
RT TJ-45 / 75

CYLINDRICAL TENSIONER
RT CT-75 / 115

**MUST BE ABLE TO ACCESS BACK OF POST TO TENSION CABLE

IN-LINE SYSTEM



RT B017-FM

(INCLUDES BOTH FITTINGS)

TURNBUCKLE / LAG JAW



EYE LAG
RT-EL-01

TURNBUCKLE
RT TB-01

LAG JAW
RT LJ-01

**SQUARE EYE
PLATE**
RT SEP-01



TURNBUCKLE
RT TB-01



LAG JAW
RT LJ-01

TURNBUCKLE / FORK JAW



EYE LAG
RT-EL-01

TURNBUCKLE
RT TB-01

FORK JAW
RT FJ-01

EYE LAG
RT-EL-01

****SQUARE EYE PLATE CAN BE USED IN PLACE OF EYE LAG**

THRU-POST SYSTEM



CYLINDRICAL TENSIONER
RT CT-75 / 115

THREADED JAWS
RT TJ-45 / 75

CYLINDRICAL TENSIONER
RT CT-75 / 115

IN-LINE SYSTEM



RT B017-FM

(INCLUDES BOTH FITTINGS)

SWAGED SYSTEM



THREADED SWAGE STUDS

RT TS-05

TURNBUCKLE / LAG JAW



EYE LAG
RT-EL-01

TURNBUCKLE
RT TB-01

LAG JAW
RT LJ-01

****SQUARE EYE PLATE CAN BE USED IN PLACE OF EYE LAG**

TENSION END FITTINGS



Tension End fittings include Threaded Terminals, Turnbuckles and Adjusters that are used to tighten the cable lines. Tension is adjusted by tightening the nuts on the Threaded Terminal fittings, spinning the tubular bodies on the Turnbuckles or rotation the bolt on the Adjusters. Every cable assembly must have at least one Tension Adjustment fitting.

75 mm Threaded Jaw



- Use with 3mm wire rope
- Thread: M6 RH 75mm long

Cylindrical Tensioner



- Thread: M6 RH
- Length: 75 or 115mm



Turnbuckle Assembly



- Use with: 3mm wire rope
- Allows for 6" of take-up

3 mm Swage Stud



- Thread: M6 RH
- Requires swaging tool



QUICK LOCK FITTINGS

The design's main function is the locking system. It uses jaws with rigged teeth to grab hold of the wire and locks them in place by screwing in the fitting.

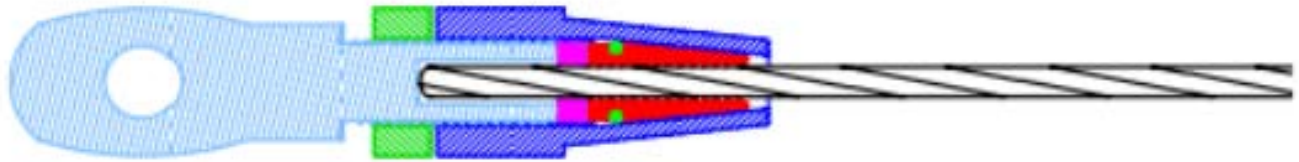

Each individual jaw has numerous rigged teeth on the inside surface. When combined, the 3-section jaw has an immense gripping power.

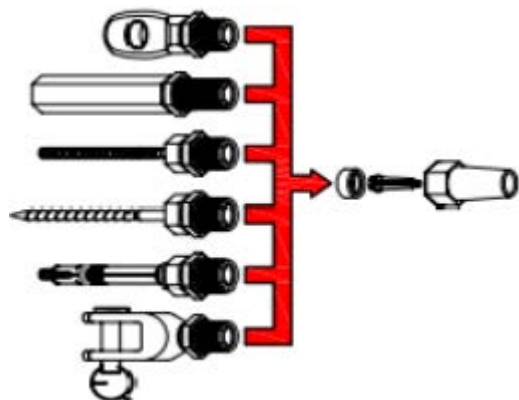

Ram Tail offers an assortment of fittings to suit any application.

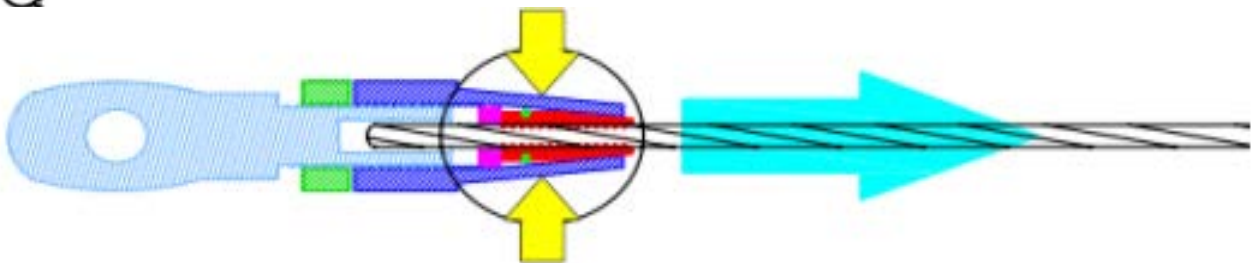

As tension is applied to the cable, the jaws are pulled against the inside of the cone shaped terminal. Due to the cone design the jaws react to the force by contracting, resulting in a greater grip on the cable. The beauty of this design is that it allows the cable to be easily tightened when necessary.

FIXED END FITTINGS



Fixed End Fittings are non-adjustable end termination fittings that have no tensioning capabilities - Therefore, each Fixed End must be paired with a Tension End fitting.

Leg Jaw



- Use with: 3mm wire rope

In-Line Rail System



- Use with Ram Tail threaded jaws
- Thread: M6 RH



Eye Lag Screw



- Highly corrosion resistant

Fork Jaw



- Use with: 3mm wire rope

Eye Lag Screw



- Use with: 3mm wire rope



STAINLESS STEEL CABLE



Why Choose Stainless Steel?

The many unique qualities of stainless steel make it a leading contender in material choice. It may be overlooked in some instances by architects and designers because it is viewed as a high cost product, however over its lifespan stainless steel is often the good value option owing to its endless list of benefits:

- **Corrosion resistant**

Depending on the choice of grade in response to its environmental setting, stainless steel is highly resistant.

- **Fire and heat resistant**

Specific grades of stainless steel that have chromium and nickel-alloys retain strength at high temperatures.

- **Aesthetic qualities**

The clean-cut visual appearance of stainless steel is easily maintained, contemporary and attractive.

- **Long-term value**

The lifespan and long-term costs of stainless steel make an attractive and less expensive material choice

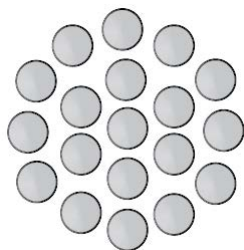

3mm 1x19 Stainless Steel wire Rope

- Premium quality, highly corrosion resistant 316 marine grade stainless steel
- Low-twist, flexible and true to size
- Low-stretch strand with smooth outer profile
- Very high breaking strength
- Highly polished and decorative

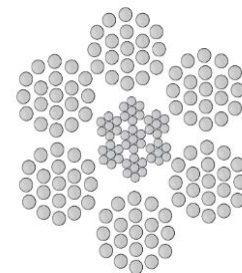

5mm 7x19 Stainless Steel Wire Rope

- Premium quality, highly corrosion resistant 316 marine grade stainless steel
- Low-twist, flexible and true to size
- Excellent all around cable, used throughout the marine and engineering industries
- Perfectly suited for most running applications, around sheaves, pulleys, control cables, cable rail, and lanyards.

HARDWARE & TOOLS



When ordering cable railing, proper layout is important for an accurate material take off. When running cables on three inch centers, ten runs are necessary to reach your 36 inch code compliant height. Most corner post will be utilized as a start and stop point, enabling another maximum run of cable. A single run of cable should be no greater than 35 feet, using a one sided tensioner application. Accomplishing runs greater than thirty feet may be reached by using tensioners on both ends of the cable.

W a s h e r



- 316 Marine Grade Stainless Steel
- Highly corrosion resistant

S q u a r e E y e P l a t e



- 316 Marine Grade Stainless Steel
- Highly corrosion resistant

H e x N u t



- 316 Marine Grade Stainless Steel
- Thread: M6 RH
- Highly corrosion resistant

A c o r n N u t



- 316 Marine Grade Stainless Steel
- Thread: M6 RH
- Highly corrosion resistant



C a b l e C u t t e r s

- Comfortably cuts up to 4mm (3/16") diameter steel wire rope
- Compact, light and very easy to handle
- Hardened steel blades, center bolt and steel handles with plastic covering
- Triangular cutting system for progressive cutting without crushing



M u l t i - s i z e d S p a n n e r

- High quality zinc plate
- Fits all Ram Tail Fittings nuts

BASIC INSTALLATION

Prior to installation, building codes should always be taken into consideration to ensure safety. Post layout is the most important step for accurate ordering and installation. Federal building code requires spacing no greater than 4 inches. to ensure compliancy, we recommend 3 inch spacing on all cables and a stanchion post every 48 inches to minimize cable deflection.

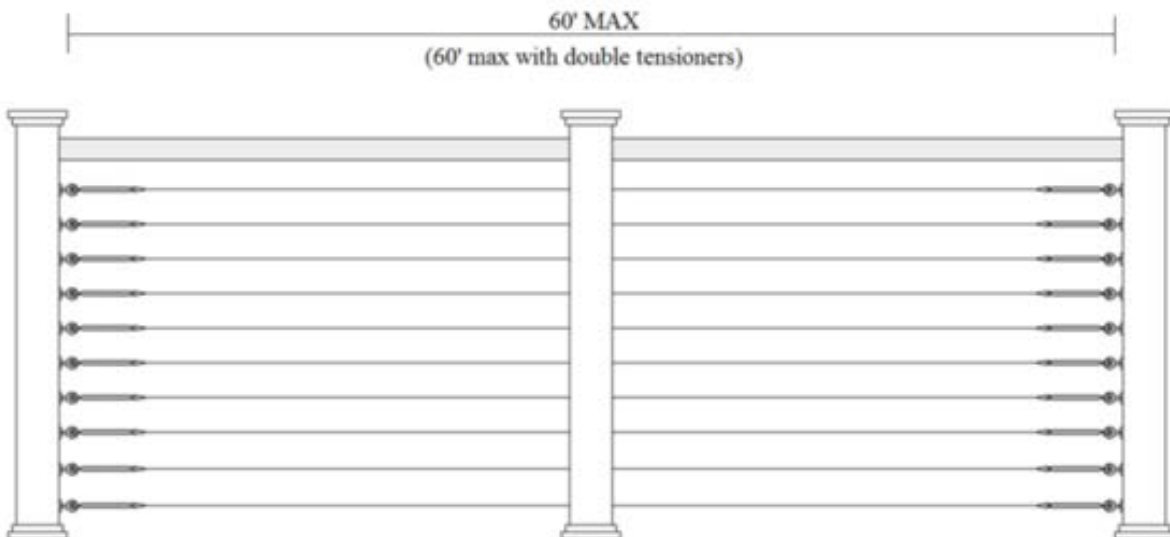
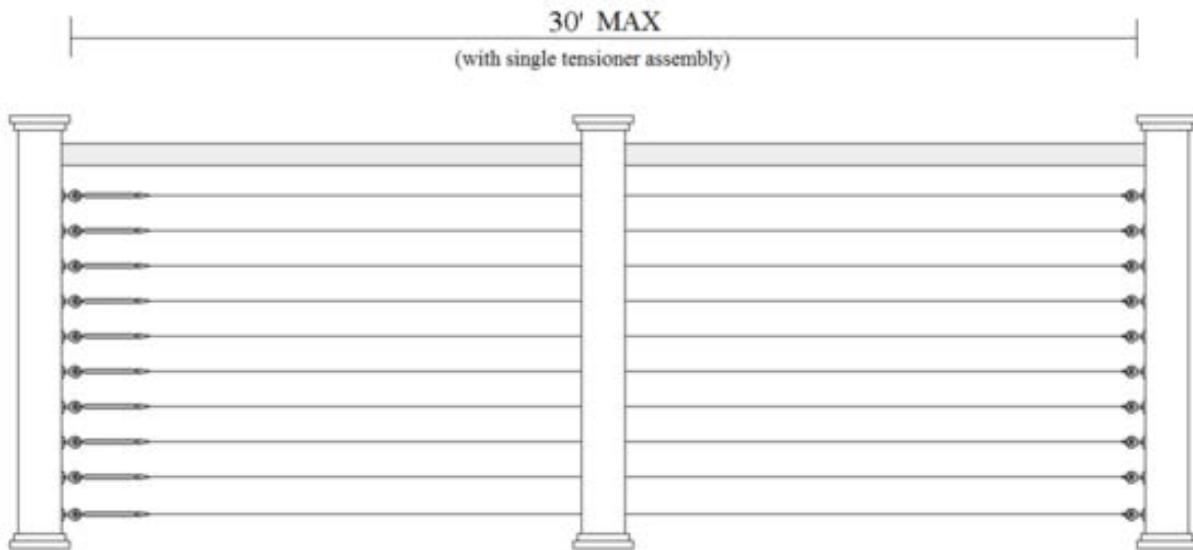

STAIR INSTALLATION

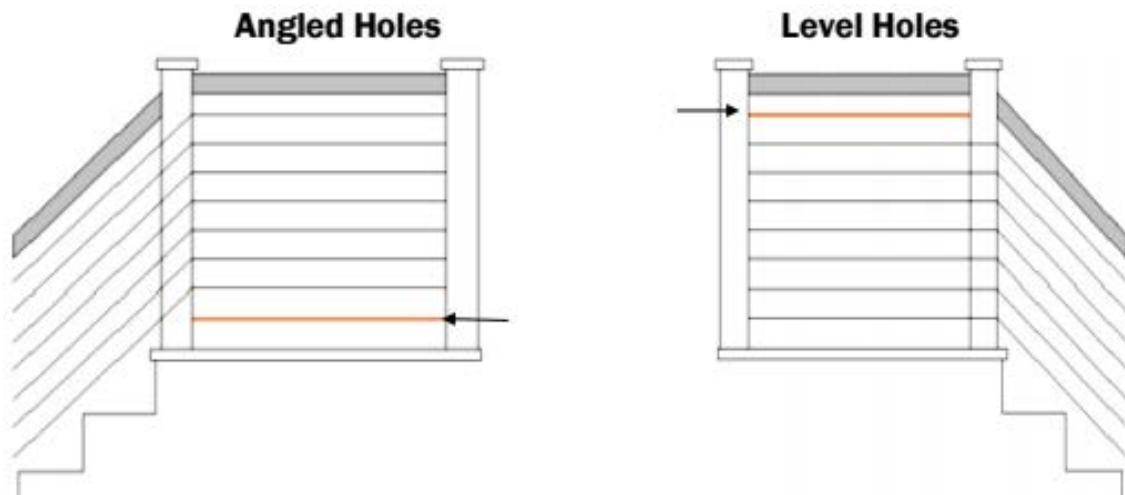

When installing cable railing on stairs, you will typically lose one run of cable on the angled section of railing. In the illustrations above you can see the result of drilling on an angle vs. drilling straight through the post. Drilling through stair post on an angle will make the lowest cable the same height of the second lowest cable as seen in figure 2, resulting in the addition of another cable run.

Drilling through post on angles may be eliminated by choosing to start and stop the run on either side of the post.

Standard Angle Post Specifications

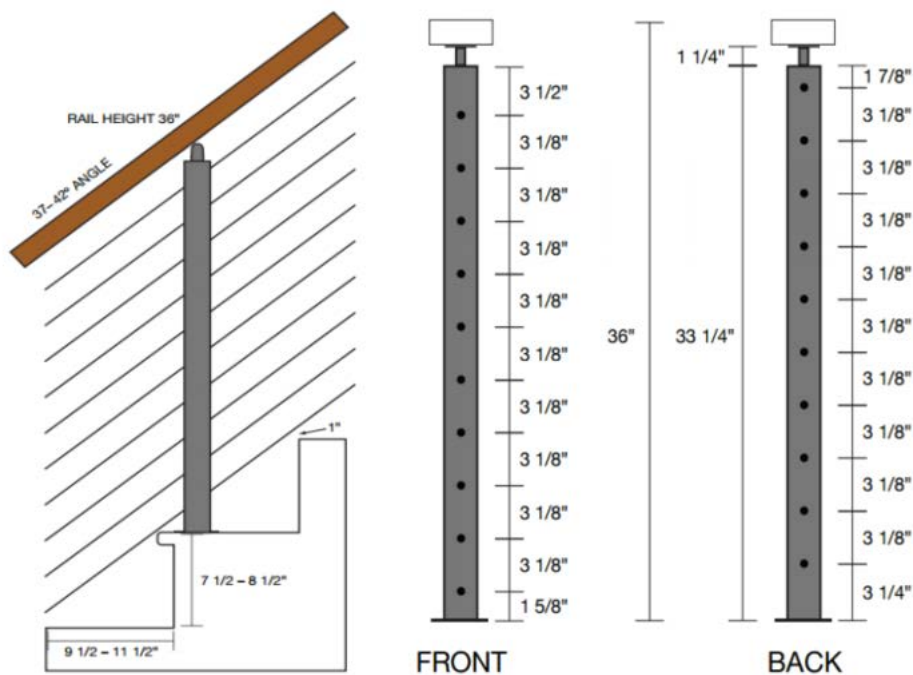



FREQUENTLY ASKED QUESTIONS

1. What is your product made of, and how well does it withstand harsh coastal environments?

All of our components are forged from 316 marine grade stainless steel, ready to withstand years of abuse.

2. Will cable hand railing pass building codes?

Code compliancy is often a concern when considering cable railing infill on your building project. National building code requires a 36" inch top rail for residential construction with spacings no greater than 4 inches. And a 42" inch top rail with the same spacing requirement for commercial. To ensure proper code compliancy, we recommend spacing cable railing 3 inches apart. To minimize cable deflection, a mid post should be spaced every 48 inches.

3. Will the cables get loose over time?



The determining factor of cable deflection is based on the material in which it is attached. Typically, wood decks and handrails will expand and contract with the ever changing climate, but given the simplicity of our system, re tensioning is quick and easy. Metal or concrete mounted fittings will typically stay tensioned for many years after proper installation.

4. Do i have to use post sleeves?

Post sleeves are designed to take pressure loads off small points of contact when cables are run through wood post on angles. Post sleeves are not necessary in all applications, but recommended on any angle over 20 degrees. Failure to use a post sleeve on angled application over 20 degrees will cause accelerated post wear, and an early cable sag.

5. How long can can I cable railing?

Cable railing can be installed with safe results on runs 30 feet or less using a single sided tensioner. Runs greater than 30' can be accomplished when using a tensioning device on both ends. Never run cables over 60 feet.



75mm Threaded Jaw

RT-TJ-75

Cylindrical Tensioner

RT-CT-75 / 115

Turnbuckle Assembly

RT-TB-01

3mm Swage Stud

RT-TS-01

Lag Jaw

RT-LJ-01

In-Line Rail System

RT-BJ-01

Eye Jaw

RT-EJ-01

Fork Jaw

RT-FJ-01

Eye Lag Screw

RT-EL-01

3mm 1x19 Stainless
Steel Wire Rope

5mm 7x19 Stainless
Steel Wire Rope

Washer

RT-FW-01

Square Eye Plate

RT-AN-01

Hex Nut

RT-HN-01

Acorn Nut

RT-SEP-02

Multi-Sized Spanner

RT-WC-01

Cable Cutters

RT-ST-01

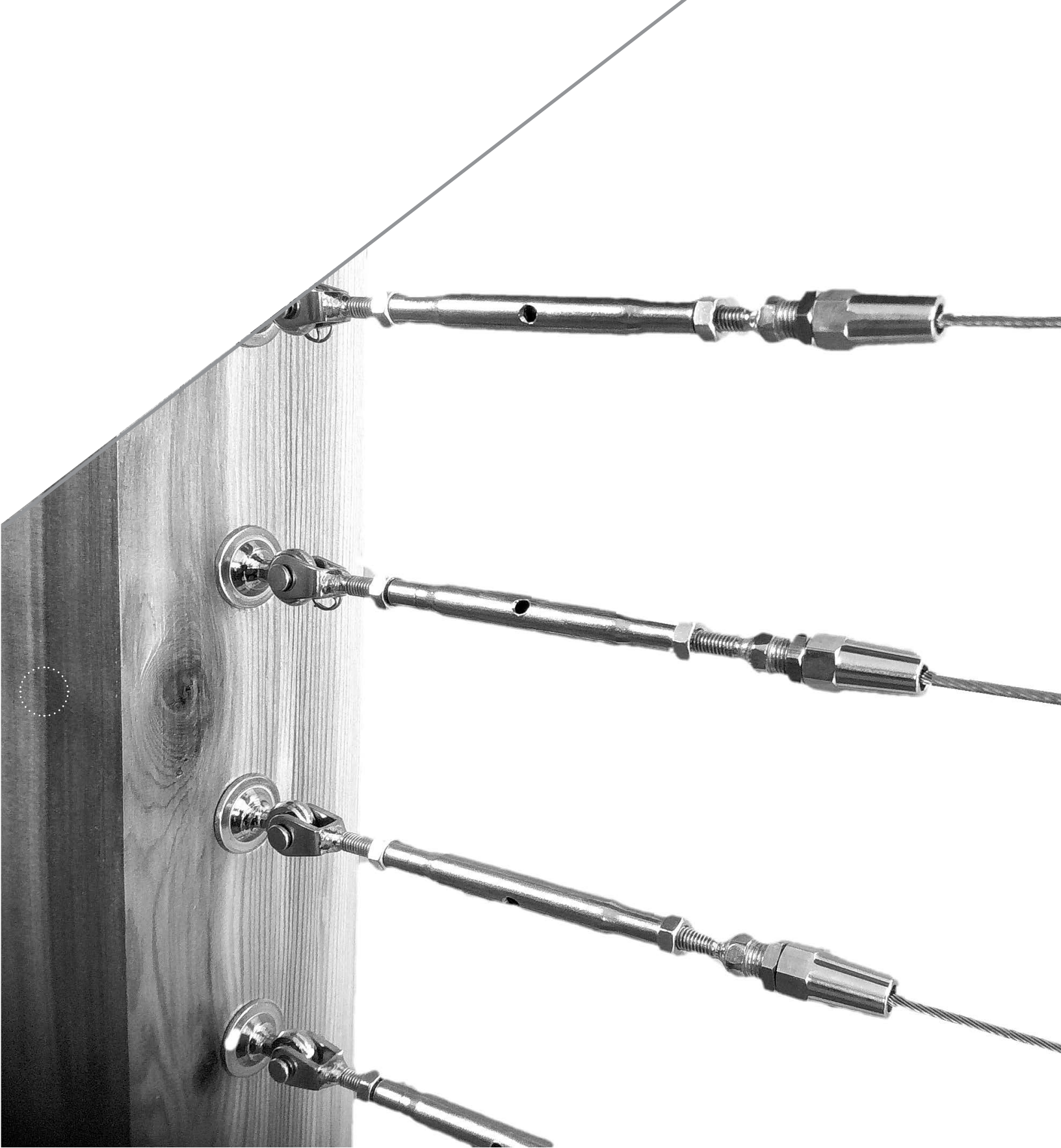

Ram Tail, LLC
Cable Rail Systems
9381 Hard Dr. Foley. AL, 36535
United States
sales@ramtail.com