

# Scoot About

## model/modèle/modelo #20

Patents pending / Brevets en attente / Patente pendiente

For ages 1 to 3 years

Pour enfants de 1 à 3 ans

Para los niños 1 a 3 años

Thank you for your purchase. If you have any questions or comments, please visit the customer service section of our website:

Merci d'avoir acheté notre produit. Si vous avez des questions ou commentaires, veuillez référer notre site web dans la section de service à la clientèle.

Gracias por su compra. Si tiene preguntas o comentarios por favor visite la sección, servicio al cliente de nuestro website:

**www.radioflyer.com**

Or phone / ou composez le / o llame al 1-800-621-7613

Available weekdays 8:00 a.m. to 5:00 p.m. CST.

Please keep this sheet for future reference.

Disponible sur semaine de 8:00 heures 17:00 heures.

Veuillez garder cette feuille comme référence.

Lunes a viernes de 8:00 a.m. a 5:00 p.m. CST.

Por favor retenga esta copia para futura referencia.

Radio Flyer Inc. / 6515 West Grand Ave. / Chicago, IL 60707

phone: 773-637-7100 fax: 773-637-8874

*The Original Little Red Wagon™ Since 1917*

### 1

**Required:**

**Nécessaire:**

**Requeridas:**

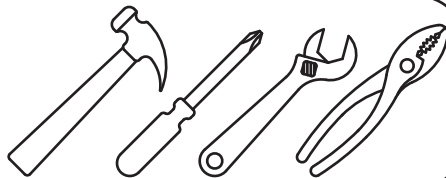

### 2

20.1003099 (x1)

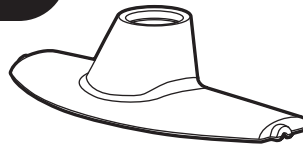

20.1003199 (x1)

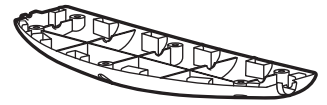

20.1003299 (x1)

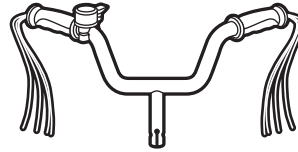

20.1003399 (x4)

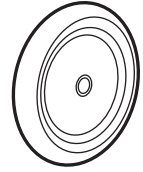

20.1003499 (x1)

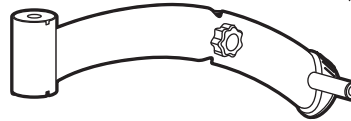

20.1003699 (x1)

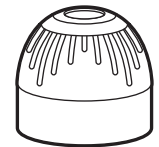

20.1004199 (x1)

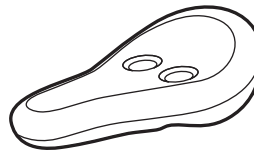

20.1003799 (x1)

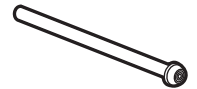

20.1003899 (x1)

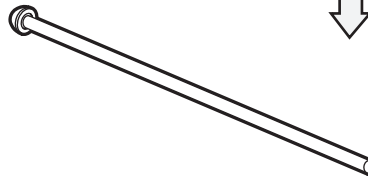

20.1004299 (x1)

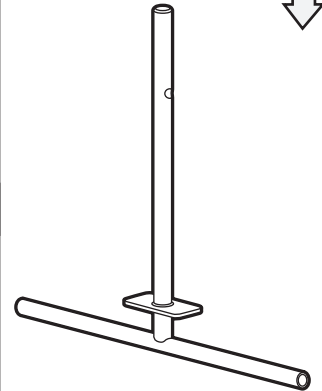

20.1004099 (x1)

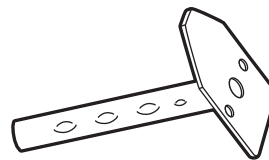

### 3

7.0450099 (x2)

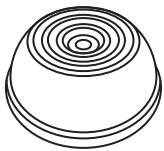

1/4.0635599 (x2)

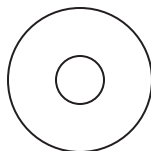

#8.0607099 (x6)



#8 x 1/2"

1/4 .0517999 (x3)



1/4 - 20

1/4 .0270399 (x2)

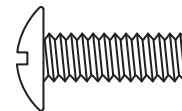

1/4 - 20 x 3/4"

1/4 .02676999 (x1)

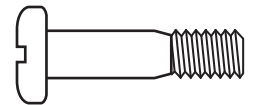

1/4 - 20 x 1"

+1 Extra  
+1 Supplémentaire  
+1 Adicional

**! If you find extra hardware items, please dispose of them and keep them away from small children.**

**Si vous avez de éléments en surplus, rangez-les dans un endroit sûr, à l'abri des bambins.**

**Desahacerse de la ferretería que le sobre, manteniéndolo fuera del alcance de los niños.**

**4****⚠ CAUTION:****ADULT ASSEMBLY REQUIRED.**

This package contains small parts which, before assembly, present a choking hazard to children under the age of three. Care should be taken during unpacking and assembly to insure that all small parts and plastic bags are accounted for and kept out of the reach of children.

**⚠ ATTENTION:****ASSEMBLAGE REQUIS PAR ADULTE.**

Cet emballage contient de petites pièces qui, avant l'assemblage, présentent un danger potentiel de suffocation avec les enfants âgés de moins de trois ans. Prendre les précautions nécessaires au cours du déballage et de l'assemblage afin de garantir que toutes les pièces et plastique sacs ont été incluses et tenues à l'écart des enfants.

**⚠ PRECAUCIÓN:****MONTAJE REQUERIDO POR ADULTOS.**

Este paquete contiene pequeñas piezas que, antes del montaje, presentan un peligro potencial de asfixia para niños de menos de tres años de edad. Se debe tener todas las piezas pequeñas y plástico bolsas y ponerlas fuera del alcance de los niños.

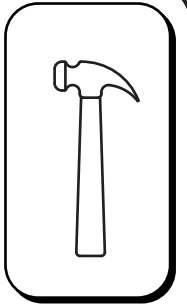
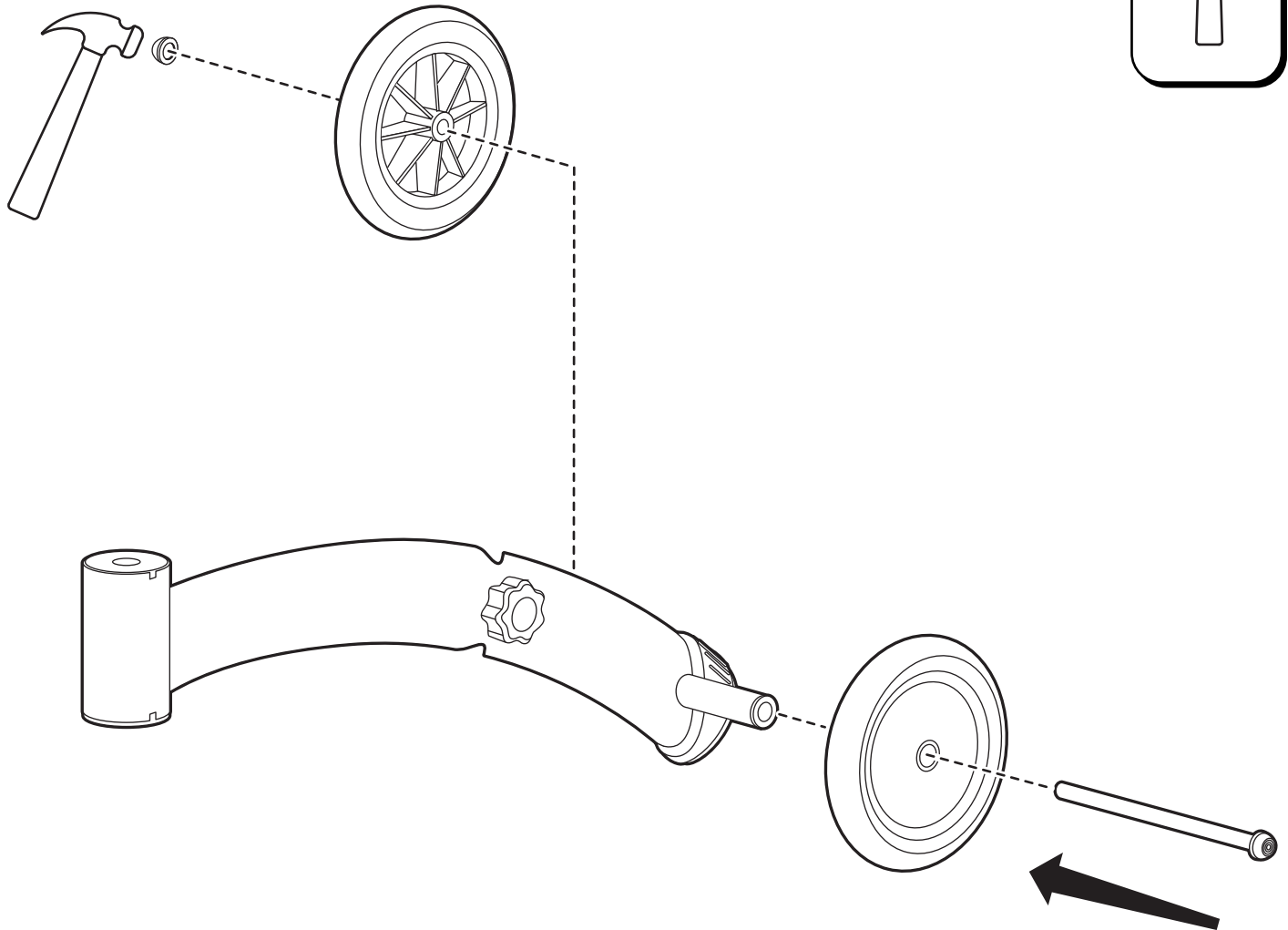
**5**

7.045099 (x1)

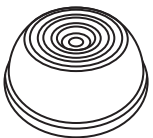

6

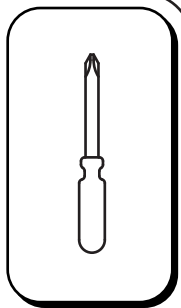

**A**

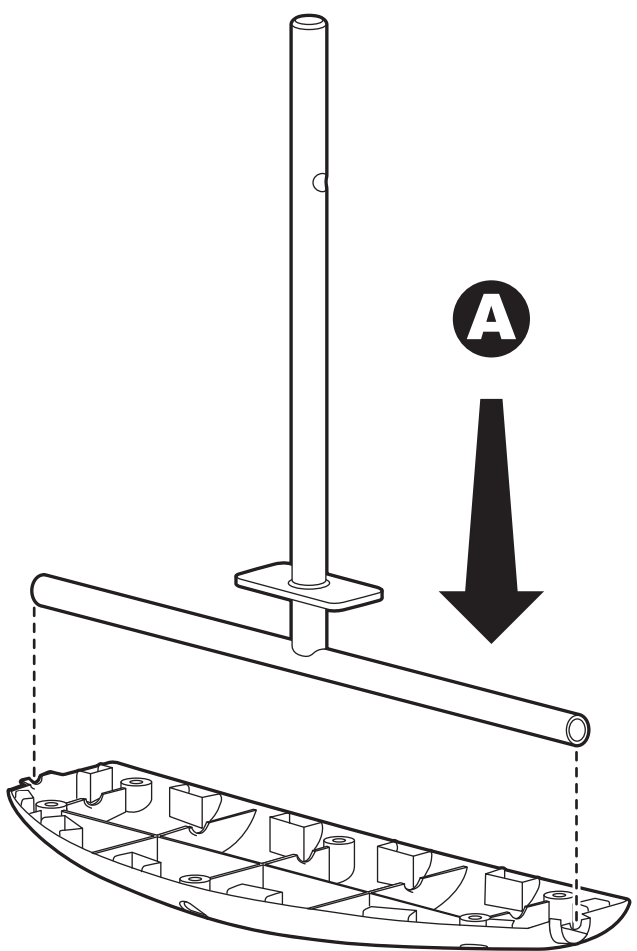

**B**

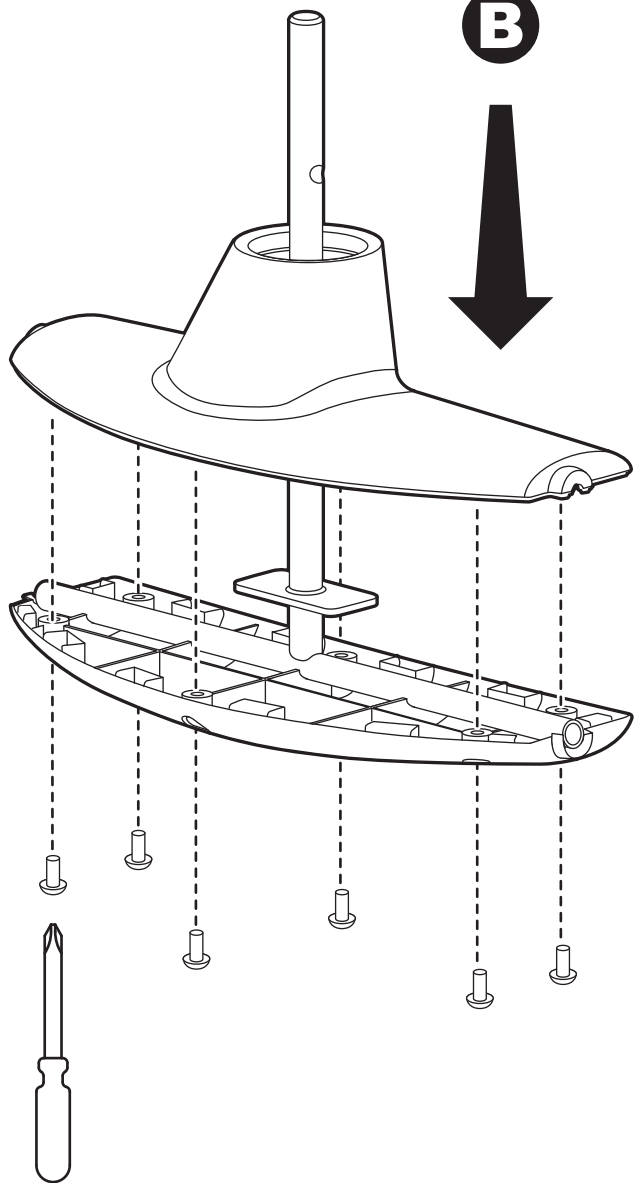

#8.0607099 (x6)

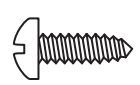

#8 x 1/2"

7

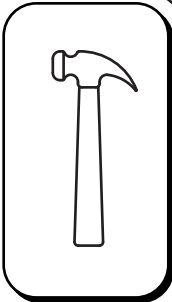
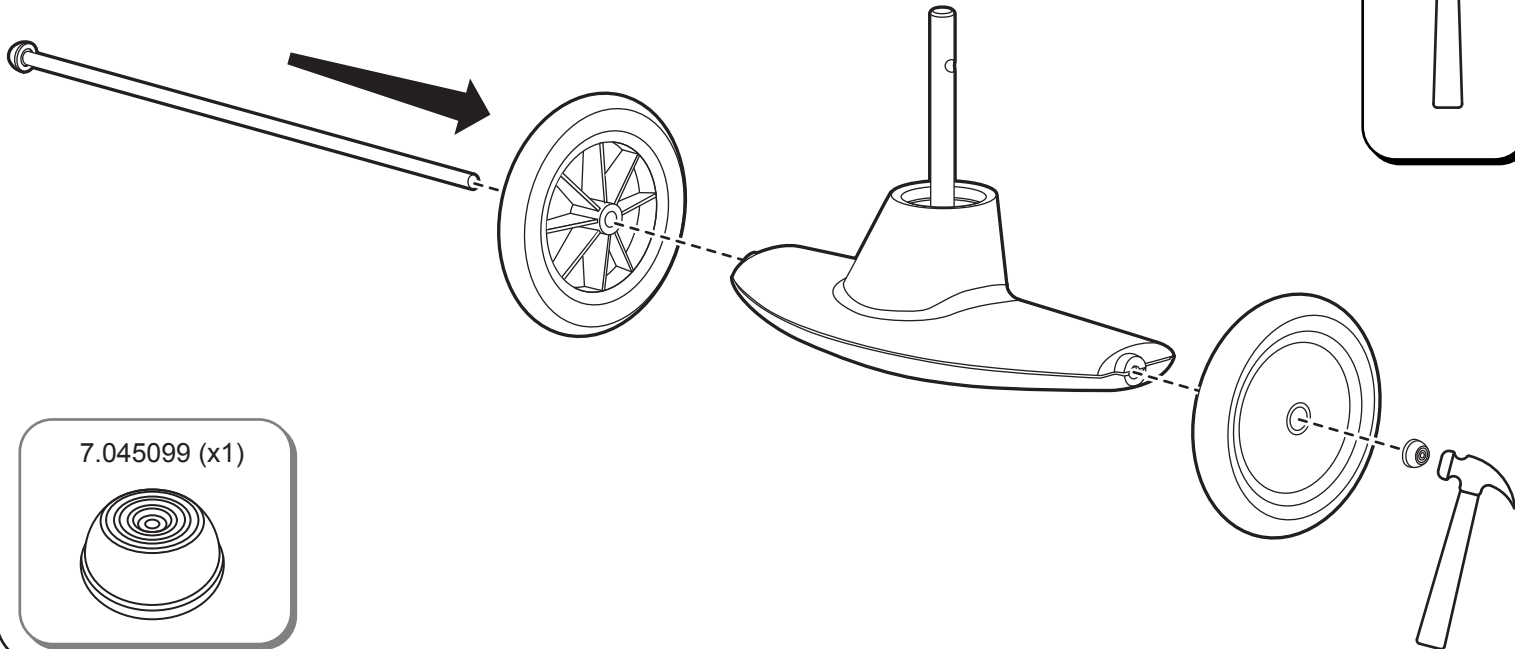

8

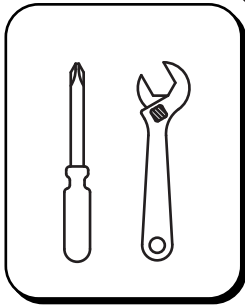
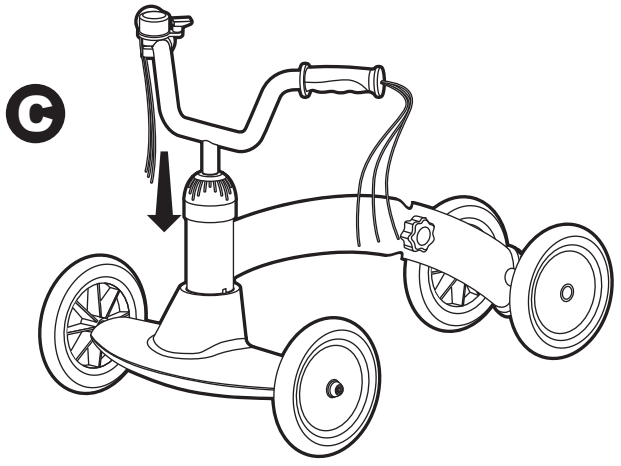
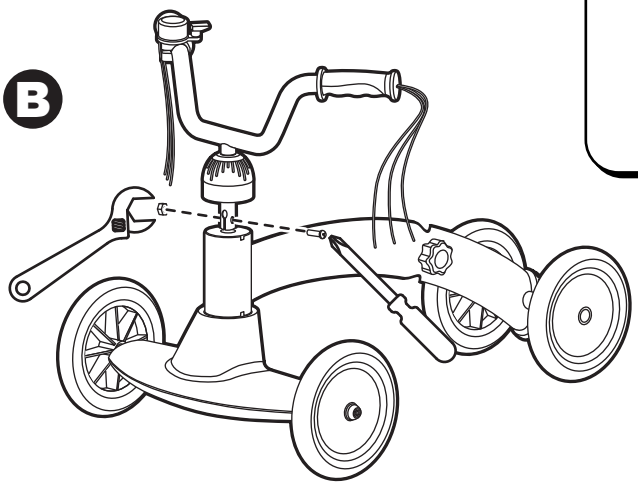
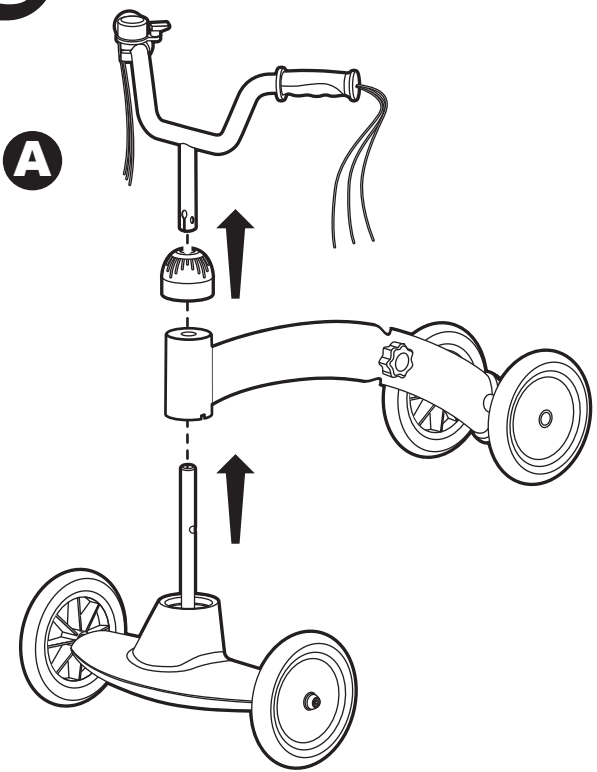

1/4 .02676999 (x1)

1/4 .0517999 (x1)

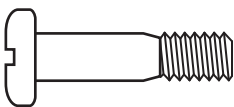

1/4 - 20 x 1"

1/4 - 20

9

1/4 .0270399 (x2)

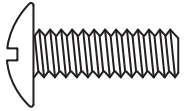

1/4 - 20 x 3/4"

1/4 .0517999 (x2)



1/4 - 20

1/4.0635599 (x2)

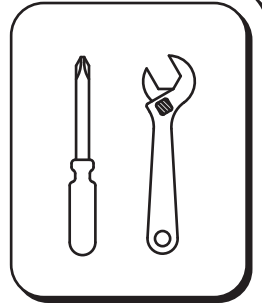
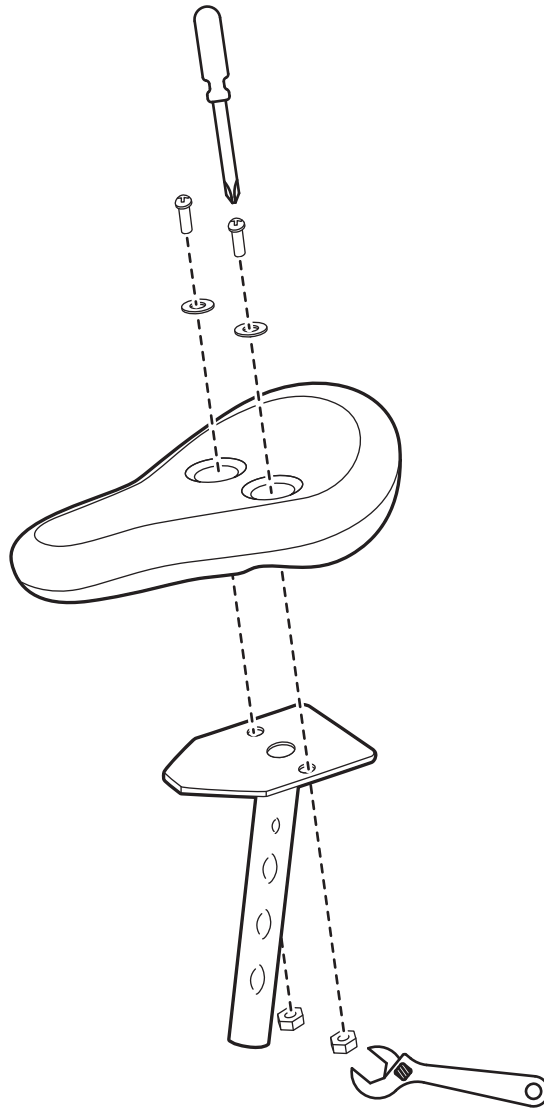
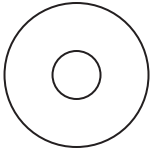

10

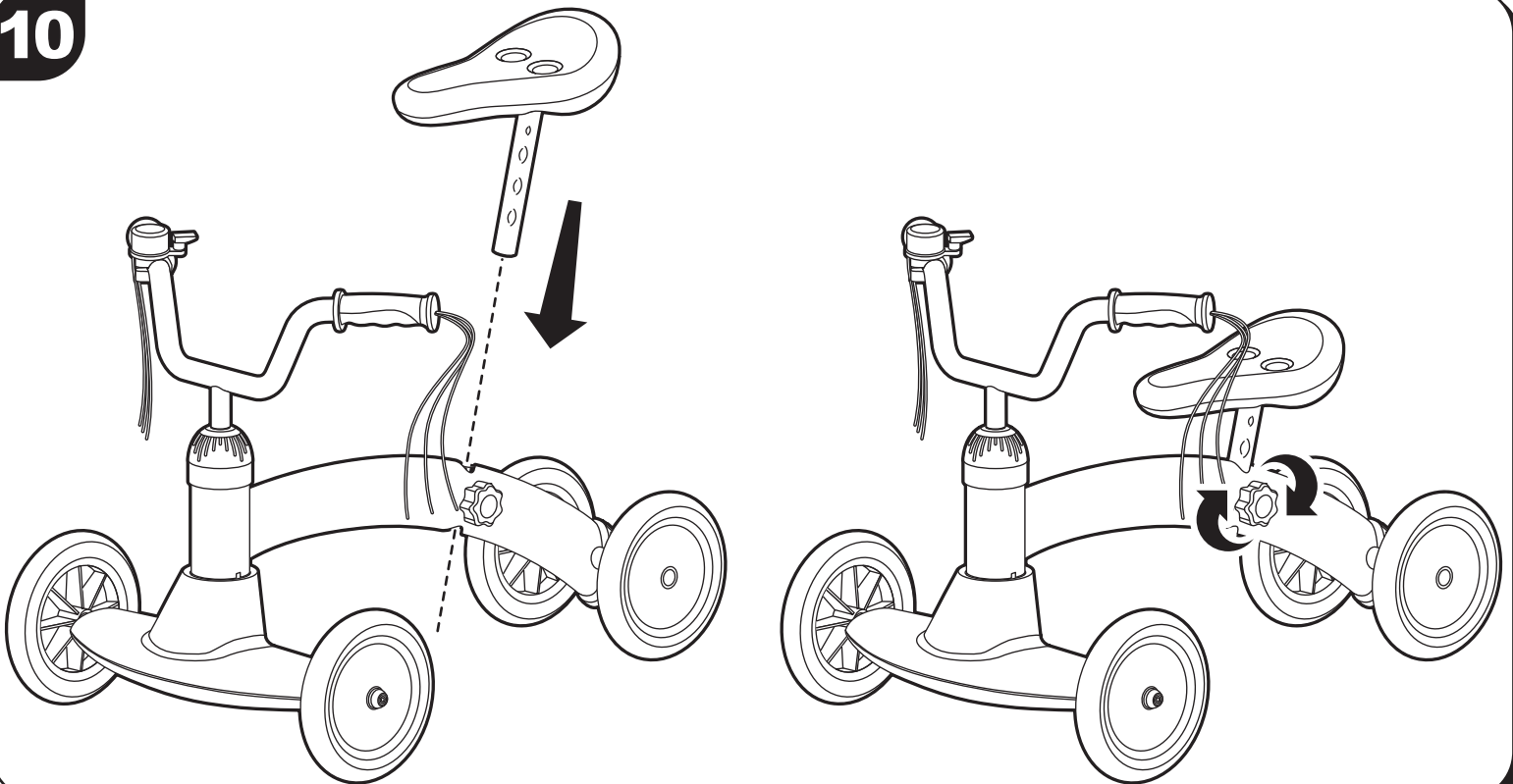

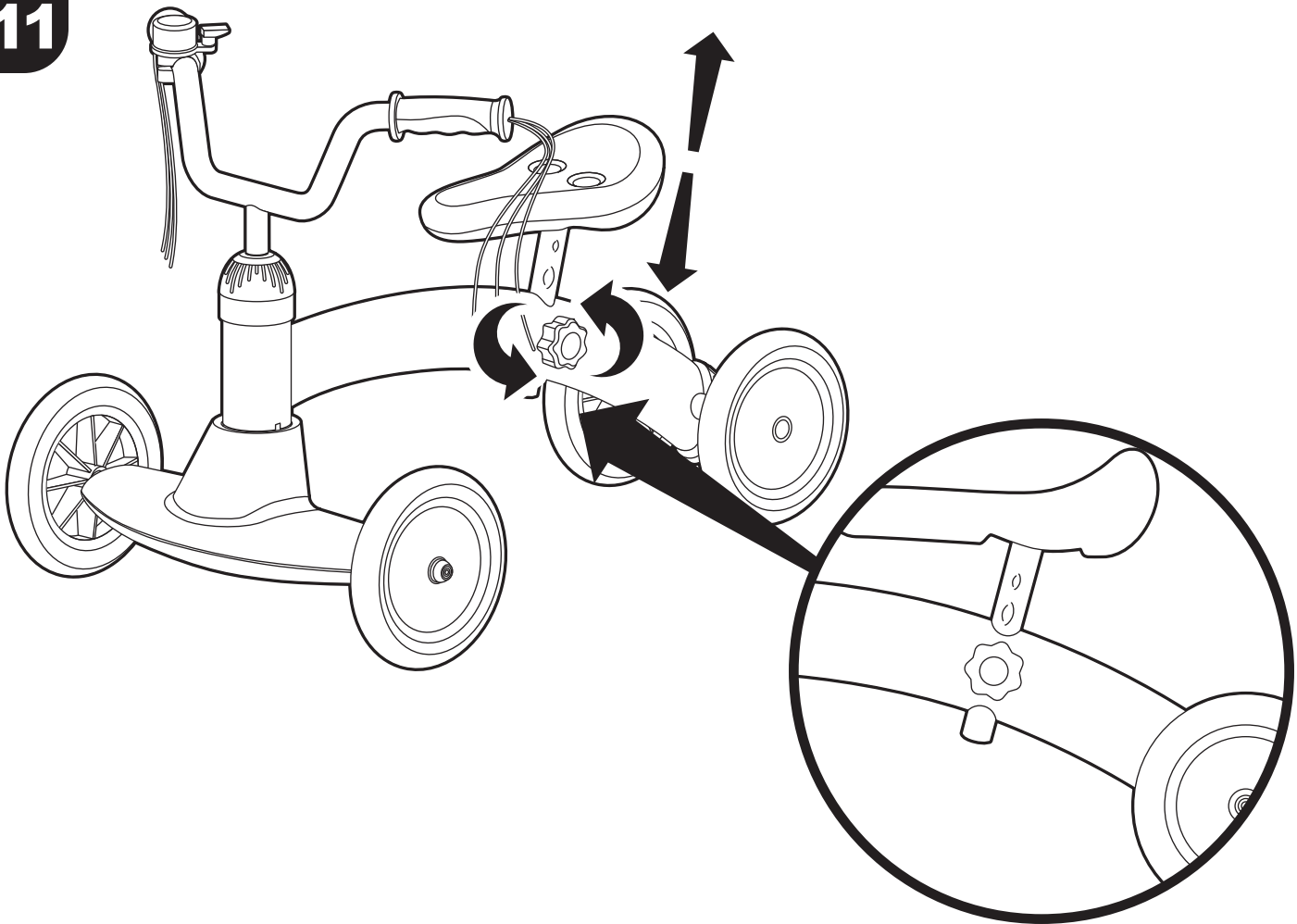

### MAINTENANCE INSTRUCTIONS

1. Check nuts and bolts often and tighten if necessary. Make certain hand grips are in place.
2. Any parts showing evidence of wear should be replaced immediately.
3. Follow closely the assembly instructions pertaining to the proper adjustment of the handle bar.
4. These instructions are valuable. It will assure your being able to obtain proper parts and service at all times. We suggest you keep it with other valuable papers.

### INSTRUCTIONS D'ENTRTIEN

1. Vérifiez souvent les boulons et écrous et resserrez les si nécessaire. Assurez vous que les poignées sont toujours bien en place.
2. Toute pièce présentant des signes d'usure doit être remplacée immédiatement.
3. Suivez attentivement les instructions d'assemblage relatives a l'ajustement correct du guidon.
4. Ces instructions sont importantes. Toute les pièces de rechange peuvent être demandées, si nécessaire, a votre distributeur. Il est conseille de conserver ces instructions.

### INSTRUCCIONES D'ENTRTIEN

1. Chequear las tuercas, tornillos y ajustarlos se están flojos.
2. Reemplazar inmediatamente las partes muy usadas.
3. Seguir de cerca la instrucciones de ensamblaje consumientes al ajuste del timón.
4. Estas instrucciones son valiosas. Aseguran que UUD pueda obtener apropiado servicio de piezas en todo momento. Le sugerimos que las mantenga con sus papeles valiosos.

### ⚠️ WARNING:

- Continuous adult supervision is required.
- Never use near motor vehicles, streets, roadways, alleys, swimming pool areas, hills, steps, sloped driveways, inclines and public highways.
- Only one rider at a time.
- Always wear shoes when using the toy.
- Periodically check hardware and tighten if necessary. Replace worn or broken parts immediately.
- Maximum weight 40 lbs.
- Make sure seat is in the locked position before use.
- Ride on smooth, paved surfaces away from motor vehicles.

### ⚠️ AVERTISSEMENT

- La supervision continu d'un adulte est exigée.
- Ne jamais utilisez près des véhicules à moteur, des rues, des chaussées, des allées, au environs des piscine, des collines, des marches, est des descente en pente des allées, des pentes et des autoroutes publiques.
- Seulement un cavalier à la fois.
- Ne conduisez jamais sans chaussures.
- Vérifiez souvent les boulons et écrous et resserrez les si nécessaire. Remplacez les pièces usées out endommagées immédiatement.
- Charge maximale 40 livres (18.1 kg).
- Assurez-vous que le siège est en position verrouillée avant l'emploi.
- Utilisation su la surface douce loin des véhicules à moteur.

### ⚠️ ADVERTENCIA

- La supervisión adulta continua requerida.
- Nunca uso cerca de automóviles, calles, carreteras, callejones, áreas de piscinas, colinas, pasos, calzadas inclinas, inclinaciones y carreteras públicas.
- Solamente un jinete a la vez.
- Use siempre los zapatos.
- Compruebe el hardware y apriete periódicamente en caso de necesidad. Reemplace inmediatamente las piezas dañadas o gastadas.
- Peso máximo 40 lbs. (18.1kg).
- Asegurarse que el asiento este en la posición asegurada antes de usarse.
- Dé un paseo en liso, superficie pavimentada lejos de los vehículos de motor.