



Workbench and Guardrail Holder Combo
Model #2204

Substantially cut work time with a workbench attached to the pump jack scaffold. Guardrail holder included.

Components below can be purchased separately.

Workbench Nose Section
Model #2202

Guardrail Holder
Model #2203

Pump Jack Brace
Model #2201

Provides rigid steel triangular bracing as required by OSHA. Used as bracing for wood pump jack poles. (Poles to be constructed in accordance with operating instructions).

Pump Jack Pole Anchor
Model #2210

Pole anchor provides additional margin of safety and security when used in accordance with instructions. Provides a mud sill in loose soil conditions.

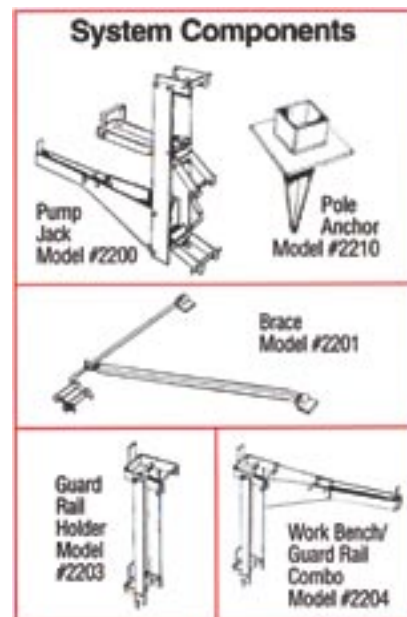

WARNING
Failure to read and follow instructions on the use of this product could result in serious personal injury. This product must be used in strict compliance with Local, State & Federal OSHA Regulations. Be safety conscious.



Product Specifications

Pump Jack & System Components

Model #	2200	2201	2213	2202	2203	2204
Description:	Pump Jack	Brace	H.D. Swivel Brace	Work Bench Nose	Guard Rail	Guard Rail/Work Bench Comb.
Unit Pack:	1	1	1 / Carton	1	1	1
Weight per Pack:	19.4 lbs.	5.2 lbs.	7 lbs.	5 lbs.	5 lbs.	10 lbs.
Cu. Ft. per Pack:	2.55	.61	1.05	.63	.55	1.33





Model 2201 Triangular Pump Jack Brace

USE OF TRIANGULAR PUMP JACK BRACES; Setting the Pump Jack Poles:

1) Space poles uniformly not more than 7 feet on center when using 2 inch thick nominal walk planks, 9 feet on center when using 2 inch undressed lumber or 11 feet on center when using aluminum walk planks. Always support aluminum walk planks longer than 12 feet at both ends and in the middle of the walk platform. Poles shall not exceed 30 feet in height. 2) Using rigid steel triangular bracing, attach a brace to the top of each pole by loosening the wing nut on the brace's clamping mechanism and sliding the clamping plates over the wood pole so that the pole's seam faces the carriage bolt. Then tighten at the desired height. Nail clamp to pole. 3) Position the poles along the work wall and secure in place. **Always use triangular steel pump jack braces. The round bar of the brace should be fastened to the work wall at right angle to the walk plank. The angle bar of the brace is then fastened to the right or left as desired. Space between the brace arms is 32 inches, enabling installation on studs 16 inches apart. The seam of the pole must face the work wall.** 4) All poles must bear on a firm foundation or mudsill. Install a pole anchor, then insert pole and secure in place. Or, using a 2"x10" square piece of lumber remove enough dirt to insert board creating a firm level foundation. Secure pole in place by blocking all four sides with 2x4's and nailing in place. 5) **Install triangular steel bracing at the bottom of the pole to prevent movement.** 6) **Additional pump jack braces must be installed vertically along each pole no more than 10 feet apart.**



Model # 2204 Workbench/Guardrail Combo

1) Remove the round pin connecting the Nose Section of the Combo. 2) Remove the round pin from the bottom of the guardrail. 3) From the platform side of the pump jack, place the guardrail over the pump jack pole such that the Guardrail retainers are on the platform side of the poles and are pointed towards the sky. 4) Re-install the bottom pin connecting the guardrail to the pump jack using the holes provided in the connector plate at the top of the pump jack and the holes at the bottom of the guardrail. Ensure that the Guardrail rests on the outside of the connector plates. Secure in place by inserting a cotter pin into the hole at the end of the pin and bending it over. 5) Place the second pin through the holes provided at the top of the guardrail installing the nose section, so that the guardrail/workbench combo will ride up and down with the pump jack and secure with a cotter pin. Ensure that the nose section rests on the inside of the guardrail. 6) Place a single length 2x4 across the scaffold connecting two pump jacks at both the middle and the top of the guardrail in the

space provided and secure with #6d common nails. Install a toe board as required onto the scaffold plank. **CAUTION:** Always install guardrails when using pump jack scaffolding. The workbench should be fully decked when in use and should be used only as a work surface for tools and materials. Never stand on workbench. Spacing between poles should not exceed 7 feet on center when using 2 inch thick nominal walk planks, 9 feet on center when using 2 inch undresses lumber, or 11 feet on center when using aluminum walk planks. Poles must not exceed 30 ft. in height and must be secured using rigid triangular steel bracing at the top, bottom and at 10-foot intervals. Mending plates must be installed at all splices. **Care & Maintenance:** Inspect all pump jack equipment including the pump jack pole before and after each use to be sure that there is no damage, deformation or deterioration due to rusting or extensive use to any of the equipment's components. Read and follow the instructions and warnings on the Qual-Craft Pump Jack before installation and use of this product.



Model 2210 Pole Anchor

General Requirements: Qual-Craft's Pump Jack Scaffolding products are intended for use by qualified professional contractors. Prior to installation, the user should review all instructions for the installation, use and care of these products. All scaffolding and accessories must be used in strict compliance with Local, State and Federal OSHA regulations.

Installation: The pump jack pole anchor has been designed to provide an additional method of securing the bottom of the Pump Jack pole and should be used in conjunction with the pump jack pole brace. After determining the location, care should be taken to insure that the ground is firm and free of small rocks or other objects. The presence of rocks or other objects could prevent the anchor from being fully seated into the ground. Soft or muddy surface areas may cause the pole to be unstable and would constitute an unsafe condition. With a small block of wood placed into the shoe, the anchor should be driven

into the ground using a hammer. Care should be taken to insure that the 8"x8" plate is resting completely on the ground and that the spike has been fully seated into the ground. The nail holes provided in the shoe should be used to secure the wood pole to the anchor after the anchor has been placed into the ground.

Care & Maintenance: Inspect the Pump Jack Pole Anchor and all other pump jack equipment including the pump jack pole before and after each use to be sure that there is no damage, deformation or deterioration due to rusting or extensive use to any of the equipment's components. Always handle pump jack scaffolding equipment with care to insure safe and lasting use. Do not throw or drop this product. Do not use this equipment if it has been exposed to extreme heat or cold. Discard at once. Do not use if wet or frozen. Read and follow the instructions and warnings on the Qual-Craft Pump Jack before installation and use of this product.

