



WORKSHOP CATALOGUE

Engineered to last



SHINN FU EUROPE B.V.
www.shinnfu.com



WARRANTY CONDITIONS For OMEGA and PRO LIFT BRAND LIFT EQUIPMENT

All Shinn Fu products are carefully supervised throughout the manufacturing process. Before sending the products to the customers, every article is checked for material and manufacturing defects. The high quality and reliability of our products is what characterizes our brands.

Shinn Fu's products are warranted against defects in material and workmanship for a period of two (2) years for both OMEGA and PRO LIFT (from the date of purchase).

Warranty terms:

The warranty applies to all Shinn Fu's products under regular conditions of use. In case the product is found to be defective by Shinn Fu (in its sole judgment); Shinn Fu will repair, replace or credit (at its option) the product without charge.

Warranty assessment:

In case of defective articles the customers have to contact a Shinn Fu Europe B.V dealer for further instructions.

WARRANTY CONDITIONS For OMEGA-MECHANIX brand products

Shinn Fu's products are warranted (for the expected life of the products) against defects in material and workmanship.

Warranty terms:

The warranty applies to all Shinn Fu's products under regular conditions of use. In case the product is found to be defective by Shinn Fu (in its sole judgment); Shinn Fu will repair or replace (at its option) the product without charge.

Disclaimers and Limitations:

This LIMITED WARRANTY does not extend to products manufactured by SHINN FU that in its sole judgment were improperly used, altered, abused or repaired by others.

- Ten (10) years limited warranty for OMEGA-MECHANIX hand tools with exception of shank bits, bit sockets, ratchet handles, torque-sockets, torque-wrenches, air impact wrench and electrical impact wrench.
- Two (2) years limited warranty for OMEGA-MECHANIX ratchet handles, torque-sockets, torque-wrenches and air impact wrenches.
- One (1) year limited warranty on all OMEGA-MECHANIX products that are equipped with a battery or 230V power lead.
- No warranty on shank bits and socket bits, or wear items like creeper wheels.

Shinn Fu is not liable for incidental or consequential costs or losses incurred by product purchaser or user.

Warranty Assessment:

In case of defective articles the customers have to contact their Shinn Fu Europe B.V dealer for further instructions.

The product price is in consideration of limiting Shinn Fu's liability for products manufactured or distributed.

WARNING!

Familiarize yourself carefully with these products before using. Know the hazards associated with their improper use. Never use these products for any purpose other than for which they are specifically intended.



SHINN FU

Under the direction and leadership of the founder Mr. Michael Hung, and the hard work and devotion of their employees, Shinn Fu Group has firmly established itself as a world leader in the automotive and hydraulic industry.

Shinn Fu Corporation was founded by Mr. Michael Hung in 1971 (based Chia-yi, Taiwan). Shinn Fu's vision is one of continuous growth and prosperity. Their goal is to generate strong growth and new levels of achievement, and to continue to make the company even more customer-focused, responsive, efficient and innovative.

The insistence of producing and offering only the highest quality products has earned Shinn Fu Group a reputation for exceptional quality in the automotive lifting equipment, hydraulic equipment, and automotive accessories with strong brands in the professional market and invaluable recognition for reliability in the DIY market.

The quality of Shinn Fu's products is recognized not only by customers worldwide, but also by international governments and industry agencies including the American National Standards Institute (ANSI), Australian Standards (AS), European Conformity (CE), Germany's Technical Inspection Association (TUV), and Japanese Industrial Standards (JIS). Every Shinn Fu product is specifically designed and engineered to not only meet, but to exceed the industry standards set forth by these organizations.

Shinn Fu's commitment to quality permeates all aspects of the organization, and it is aggressively assimilating the International Quality Assurance System into its production fold. Currently Shinn Fu has three plants that are ISO9001, ISO14000 and QS9000 compliant, and a mechanical jack manufacturing plant that conforms to rigorous automotive industry Quality Assurance (QA) standards. All other facilities in the Shinn Fu Group have initiated programs to reach compliance in the near future in order to progress toward Shinn Fu's goal of total quality system compliance. Shinn Fu is committed to continuous upgrades all of its facilities to ensure that they remain state-of-the-art.

Shinn Fu possesses a valuable, substantial and global patent portfolio that covers many important inventions in hydraulics, lifting, and automotive accessories. Shinn Fu is also devoted to supplying safe user-friendly product lines.

In order to provide our customers with excellent after-sales service, Shinn Fu has established worldwide branch offices in the USA, Canada, Australia, Hong Kong, Japan and Europe. This global presence facilitates the establishment of strong customer relationships and allows Shinn Fu to provide more effective customer assistance.

Shinn Fu Europe B.V. (SFE) was established in 1994 in The Netherlands. With the objective of promoting and distributing Shinn Fu's products in the markets of Europe, Middle East and Northern Africa, SFE launched the Omega Lifting Equipment program beginning in 1994. Since then, Omega has won the market's recognition.

SFE maintains the following divisions:

- BVA Hydraulics™
- Omega Lift Equipment®
- Omega Mechanix
- Pro-Lift®

Thanks to our customers' trust and support in the past years, SFE is definitely encouraged to devote time and effort to the continuation of efficiently distributing high quality and innovative products to our customers throughout the region.

Professional lifting equipment



Hydraulic bottle jacks	Page 8
Specifications	Page 9
Hydraulic service jacks	Page 10 - 12
High lift	Page 13
Specifications	Page 14 - 15
Hydraulic service jacks	Page 16 - 17
Specifications	Page 18
Air actuated axle jacks	Page 19 - 23
Specifications	Page 24 - 25
Stabilisation Products	Page 26 - 27
Jack stands	Page 28
Axle stands & high stands	Page 29
Specifications stands	Page 30
Hydraulic pit jack	Page 31
Transmission jacks	Page 32 - 33
Specifications	Page 33
Body repair kits	Page 34
Engine cranes	Page 35 - 36
Specifications	Page 37
Engine stands & supports + specs	Page 38 - 39
Presses + specs.	Page 40 - 41
Bench & shop presses + specs.	Page 42 - 43
Wheel arm & pipe bender	Page 44
Car dolly + Tyre handling equipment	Page 45 - 47
Pumps & cylinders + specs.	Page 48 - 49

Magic Lift

- Magic Lift for fast and time-saving operation.
- Reaches the lifting point with only one stroke.

Magic Lift™

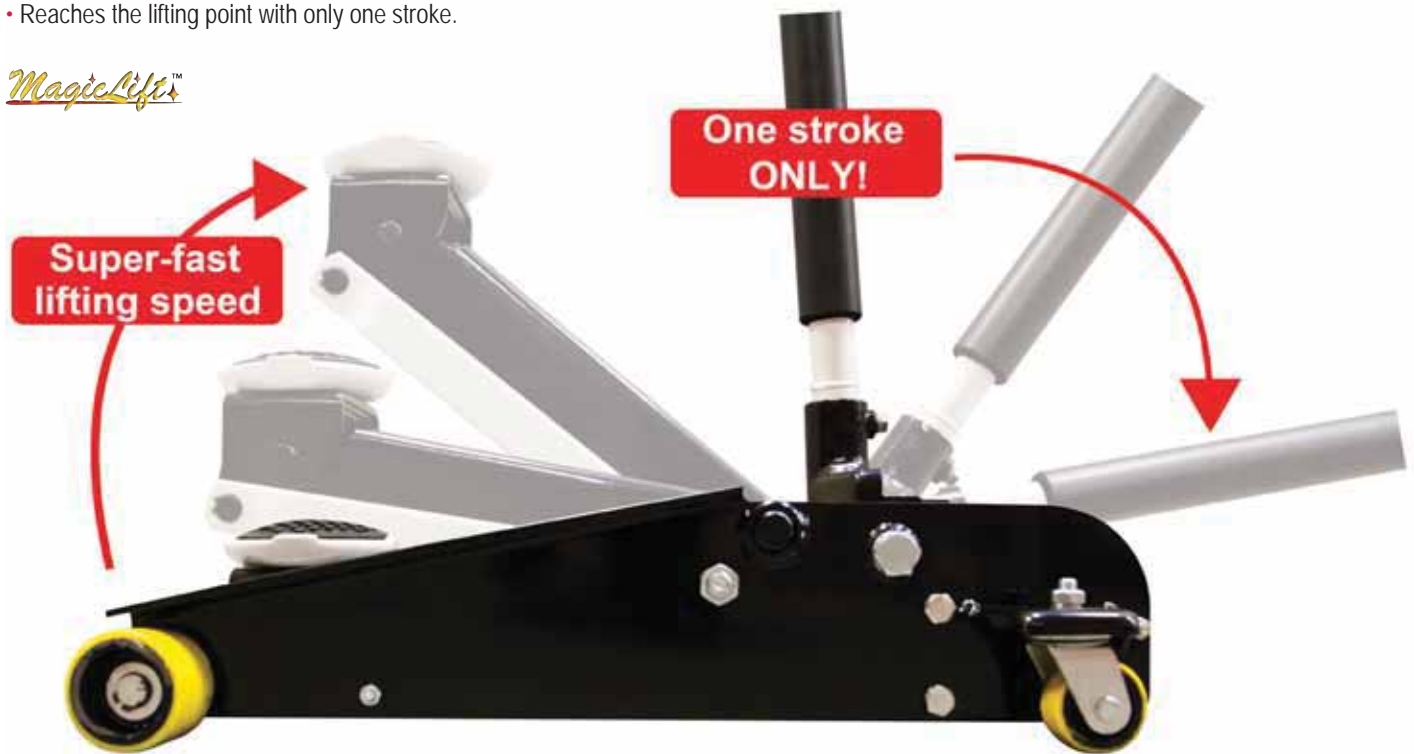

1. Soft Handle Foam

Soft Foam for extra protection. Prevents handle from accidentally damaging the car.



2. Saddle pad

Patented airvented soft saddle pad prevents vehicle's chassis against scratching.



3. Full cover Saddle pad

Patented airvented soft saddle pad prevents vehicle's chassis against scratching.



4. Universal Joint Mechanism

Universal joint release mechanism provides precision control of load descent in any handle position.



5. Gear Type

Traditional and proven transmission.



6. Air Vent Valve or Oil Filler Plug

Exclusive designed breather plug automatically eliminates air in the hydraulic system, optimizing jack's performance.



General Features

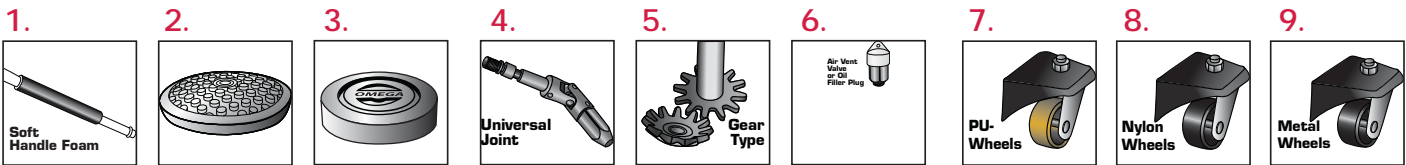

7. PU-Wheels

PU-Wheels for easy and silent moving prevent damage to oil tight garage floors.



8. Nylon Wheels

Nylon wheels for easy and silent moving prevent damage to oil tight garage floors.



9. Metal Wheels

Metal wheels, long lasting and strong.



Handle

Handle

Handle

Handle

Handle

Round-Shape handle

T-Shape handle

With Air Return

With Air Return



Hydraulic bottle jacks

Heavy duty

Hydraulic bottle jacks >

Model: 1102500 - 1104500 - 1106500 - 1108500 - 1112500 - 1112900
1120500 - 1120900 - 10500 - 10990

- With easy adjustable extension screw [2-20 Ton].
- With rubber removable carry ring for easy storage of pump handle [2-20 Ton].
- Safety valve against over-loading.
- Bottle Jacks 8 Ton and more are supplied with a carry grip.



< Hydraulic welded bottle jacks

Model: 1412000 - 1420000 - 1430000

- With easy adjustable extension screw.
- Safety valve against over-loading.
- Bottle Jacks are supplied with a carry grip.



Telescopic bottle jacks >

Model: 1202100 - 1204100

- Telescopic ram plunger combines a compact construction with a long hydraulic stroke.



< Air-actuated bottle jacks

Model: 1820200 - 1730200 - 1820600 - 1850200

- 8 - 12 BAR suggested air-pressure for optimal performance.

Specifications

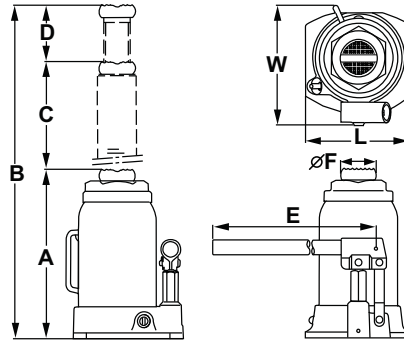

Heavy duty

Model	1102500	1104500	1106500	1108500	1112500	1112900	1120500	1120900	10500	10990
Capacity	2 ton	4 ton	6 ton	8 ton	12 ton	12 ton	20 ton	20 ton	50 ton	100 ton
A (mm)	184	208	221	231	240	157	244	169	305	305
B (mm)	349	393	434	451	470	274	474	286	483	461
C (mm)	110	125	133	150	150	77	150	77	178	156
D (mm)	55	60	80	70	80	40	80	40	-	-
E (mm)	340	448	448	460	460	460	460	460	593	600
F (mm)	25	27	31	34	43	43	52	52	79	113
L (mm)	100	109	118	120	140	164	138	164	275	305
W (mm)	98	100	105	122	130	154	130	150	198	238
N.W. (Kg)	3.0	4.0	5.0	6.2	8.0	6.3	12.5	9.6	50.4	90.6
G.W. (Kg)	12.8	17.3	21.9	24.9	33.5	26.0	26.1	20.5	54.9	97.2
Pieces Carton	4	4	4	4	4	4	2	2	1	1
CBM/CTN	0.013	0.019	0.019	0.025	0.029	0.029	0.020	0.014	0.034	0.044
Pcs/20ft Cont.	5600	3900	3300	2900	2100	2668	1300	1766	328	185

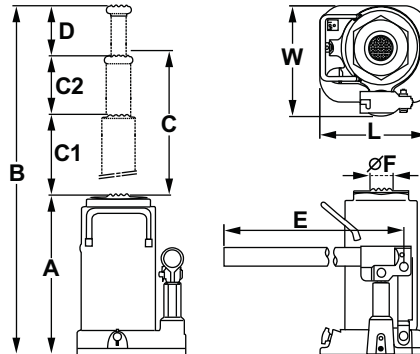

Model	Heavy duty - Welded			- Telescopic		- Air Actuated			
	1412000	1420000	1430000	1202100	1204100	1820200	1820600	1730200	1850200
Capacity	12 ton	20 ton	30 ton	2 ton	4 ton	20 ton	20 ton	30 ton	50 ton
A (mm)	241	249	268	170	173	247	245	280	305
B (mm)	469	475	480	375	418	477	478	458	483
C (mm)	150	150	155	205	201	130	80	180	178
C1 (mm)	-	-	-	103	104	-	-	-	-
C2 (mm)	-	-	-	102	106	-	-	-	-
D (mm)	78	76	57	-	35	100	153	-	-
E (mm)	452	452	695	345	445	600	600	965	600
F (mm)	42	76	67	28	32	48	52	62	79
L (mm)	138	160	190	110	130	216	230	260	280
W (mm)	106	150	152	122	120	184	173	210	187
N.W. (Kg)	8	12.5	20	4	5.4	17.0	17.6	27.5	58.4
G.W. (Kg)	8.25	13	20.8	24	23.1	17.9	18.4	28.5	63.3
Pieces Carton	4	2	1	6	4	1	1	1	1
CBM/CTN	0.027	0.018	0.014	0.031	0.024	0.017	0.017	0.031	0.0395
Pcs/20ft Cont.	2000	1200	800	4554	2980	1005	976	632	284

Hydraulic Service Jacks

Gear Type & Universal joint

2902401 >

Capacity: 2.25 Ton
 Max: 495mm
 Min: 135mm



MagicLife™



< 2103001

Capacity: 3 Ton
 Max: 494mm
 Min: 140mm

Equipped with traditional handle and convenient foot pedal.

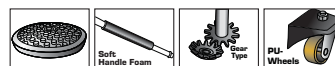

2903501 >

Capacity: 3.2 Ton
 Max: 504mm
 Min: 145mm

Extra wide wheels and solid stance designed for stability under load stress.

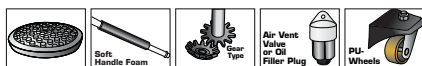

MagicLife™



< 2903101

Capacity: 3 Ton
 Max: 460mm
 Min: 120mm

Universal joint mechanism



MagicLife™



Hydraulic Service Jacks

Universal joint



< 2602701

Capacity: 2.7 Ton
 Max: 485mm
 Min: 103mm

Full aluminum jack

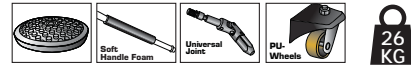

2702701 >

Capacity: 2.7 Ton
 Max: 480mm
 Min: 100mm

Aluminum frame with steel lifting arm



< 2903701

Capacity: 3.2 Ton
 Max: 558mm
 Min: 140mm

Universal joint mechanism



MagicLife™



2903011 >

Capacity: 3.5 Ton
 Max: 533mm
 Min: 100mm

Universal joint mechanism



MagicLife™



Hydraulic service jacks

Low profile universal joint

2102701 >

Long reach

Capacity: 2 Ton
 Max: 375mm
 Min: 80mm

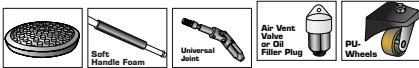

MagicLift™

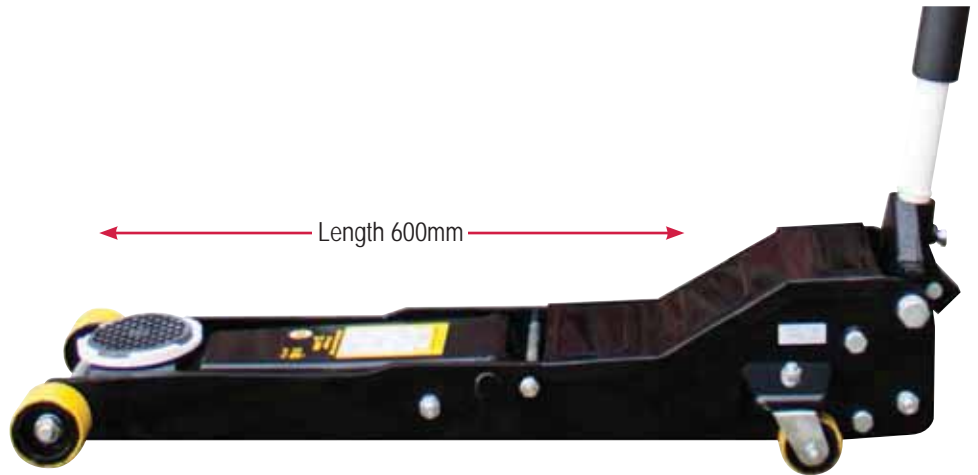

2902301 >

Only 63mm high / Extra long reach

Capacity: 2 Ton
 Max: 508mm
 Min: 63mm

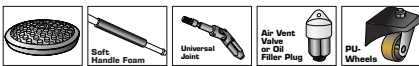

MagicLift™



2902501 >

High lifting range 63 - 500mm

Capacity: 2.25 Ton
 Max: 500mm
 Min: 63mm



MagicLift™



2903201 >

High lifting range 85 - 500mm

Capacity: 3 Ton
 Max: 500mm
 Min: 85mm



MagicLift™



High lift Universal joint

2501503 >

T-Shape handle

Capacity: 1,5 Ton

Max: 815mm

Min: 100mm



MagicLife™



**T-Shape
Handle**

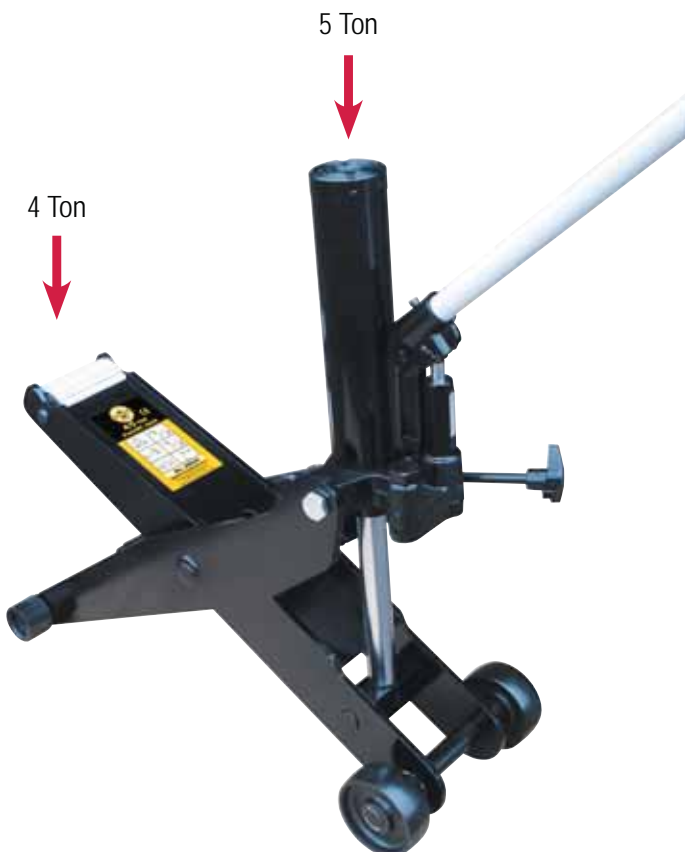

< 28045

Forklift jack

Capacity: 4 Ton

Max: 435mm

Min: 55mm

Capacity: 5 Ton

Max: 765mm

Min: 430mm

- Dual lift points for servicing forklift trucks, vehicles or machinery with low or high ground clearance.







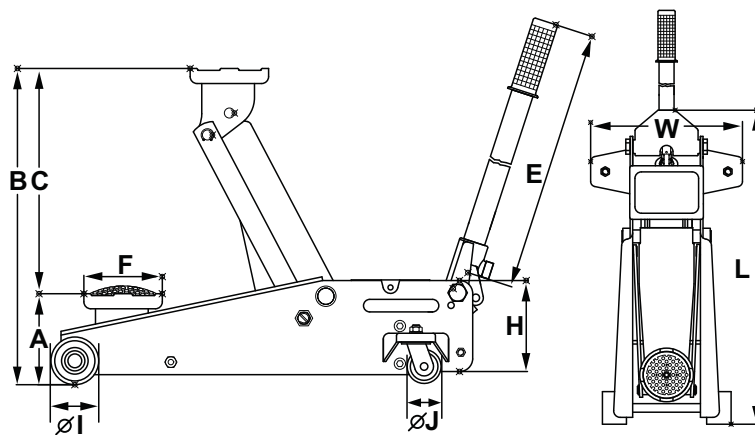

Optional 32075
capacity: 7 Ton

Specifications



Hydraulic service jacks

Model	2902401	2602701	2702701	2103001	2903101	2903501	2903701
Capacity	2 ton	2.7 ton	2.7 ton	3 ton	3 ton	3.2 ton	3.2 ton
A (mm)	135	103	100	140	120	145	140
B (mm)	495	485	480	494	460	504	558
Stroke C (mm)	360	382	380	354	-	359	418
E (mm)	1070	1210	1210	1070	1150	1070	1320
F (mm)	100	100	100	125	110	125	125
I (mm)	76	65	65	92	76	76	92
J (mm)	43	55	55	58	43	58	43
L (mm)	636	730	705	697	678	690	758
W (mm)	335	332	332	341	334	336	351
H (mm)	165	160	160	160	161	160	165
 N.W. (Kg)	31,5	26	31	37,6	32,3	37,2	39,8
 G.W. (Kg)	33,0	271	32,6	39,0	34,3	38,5	42,8
Pieces Carton	1	1	1	1	1	1	1
CBM/CTN	0.043	0.056	0.053	0.064	0.043	0.062	0.066
Pcs/20ft Cont.	620	500	500	440	500	445	420
 Soft Saddle-Pad	x	x	x	x	x	x	x
 Universal Joint	-	-	-	-	x	-	x
 Air vent valve or oil filter plug	-	-	-	x	x	x	x
 Wheels	PU	PU	PU	PU	PU	PU	PU

Specifications

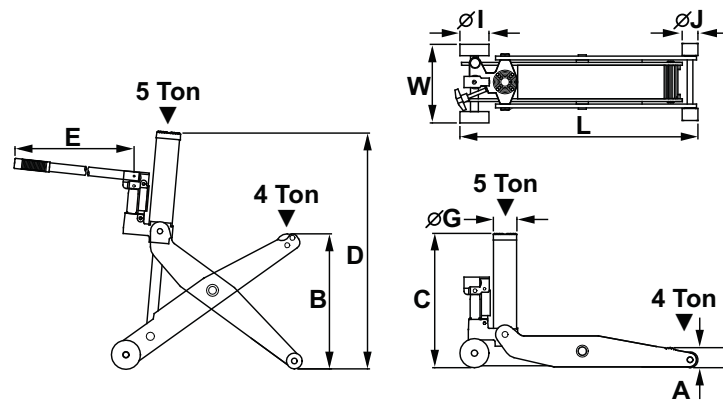

service jacks	Low profile				High lift	Forklift
2903011	2102701	2902301	2902501	2903201	2501503	28045
3.5 ton	2 ton	2 ton	2.25 ton	3 ton	1.5 Ton	4 Ton
100	80	63	63	85	100	55
533	375	508	500	500	815	435
433	295	445	437	415	715	430
1320	1320	1320	1320	1320	1342	765
110	125	125	125	110	140	750
85	72	60	60	72	92	75
40	58	58	43	40	58	100
738	955	1078	762	692	1029	50
344	349	349	345	344	385	755
161	170	175	145	158	170	255
38.9	44.3	52.5	39.5	38	52	38.5
41	48.5	54.9	41.5	39	56.5	41.3
1	1	1	1	1	1	1
0.059	0.094	0.107	0.064	0.057	0.090	0.070
480	306	270	456	500	286	348
x	x	x	x	x	x	-
x	x	x	x	x	x	-
x	x	x	x	x	x	-
PU	PU	PU	PU	PU	Nylon	Metal

Hydraulic service jacks

Long chassis

2505700 >

Capacity: 5 Ton
Max: 565mm
Min: 165mm



Magic Lift™



Round-Shape
Handle



< 2510700

Capacity: 10 Ton
Max: 686mm
Min: 175mm



Magic Lift™



Round-Shape
Handle



Hydraulic service jacks

Long chassis - air operated

22101C >

Capacity: 10 Ton

Max: 686mm

Min: 178mm



22201 >

Capacity: 20 Ton

Max: 660mm

Min: 190mm





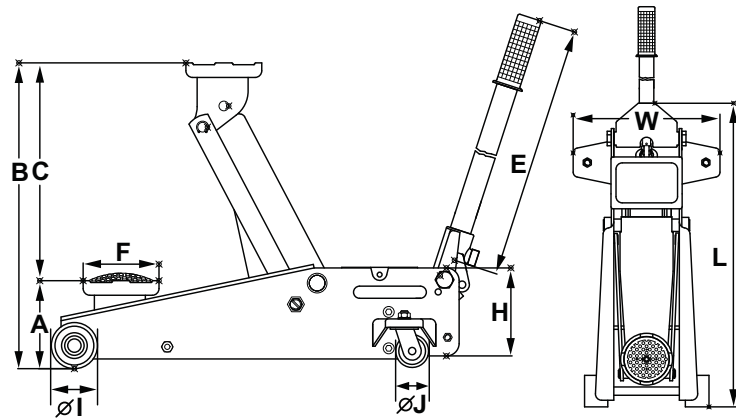

- 8-14 BAR suggested air-pressure for optimal performance.
- 3-Ways to operate: by air, manually and with foot pedal.



Specifications



Hydraulic Service Jacks

Model	2505700	2510700	22201	22101C
Capacity	5 ton	10 ton	20 ton	10 Ton
A (mm)	165	175	178	190
B (mm)	565	686	686	660
Stroke (mm)	400	511	508	470
E (mm)	1068	1215	1069	1346
F (mm)	167	167	188	155
I (mm)	110	130	150	150
J (mm)	70	100	100	100
L (mm)	1338	1309	1390	1580
W (mm)	428	499	507	517
H (mm)	281	245	324	300
 N.W. (Kg)	85.5	130.0	163	220
 G.W. (Kg)	91.5	140.0	200.0	259.1
Pieces Carton	1	1	1	1
CBM/CTN	0.144	0.253	0.368	0.461
Pcs/20ft Cont.	200	90	60	50
 Soft Saddle-Pad	x	x	x	x
 Universal Joint	x	x	x	x
 Air vent valve or oil filter plug	x	x	x	x
 Wheels	Metal	Metal	Metal	Metal

Air actuated axle jacks

Telescopic - Air Return



Air actuated axle jacks

- Compact low profile design.
- Easy access between wheels of tandem axle trucks.
- 8-12 BAR suggested air-pressure for optimal performance.
- Extension adaptors included.

23152 >

Capacity:	15 / 30 Ton
Max with adaptor:	409mm
Max without adaptor:	289mm
Min:	150mm

Adaptors



Air actuated axle jacks

Telescopic - Air return

23212 >

2 stage

Capacity: 20 / 40 Ton

Max with adaptor: 559mm

Max without adaptor: 289mm

Min: 150mm

With air return handle

Adaptors



120mm 75mm 45mm 30mm



Air actuated axle jacks

Telescopic - Air return

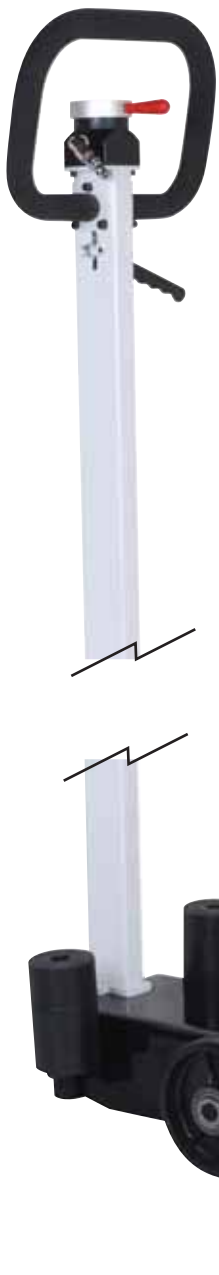

< 24213

3 stage

Capacity: 20 / 40 / 60 Ton

Max with adaptor: 597mm

Max without adaptor: 327mm

Min: 150mm

With air return handle

Adaptors



120mm 75mm 45mm 30mm



24113 >

3 stage - low profile

Capacity: 10 / 20 / 40 Ton

Max with adaptor: 559mm

Max without adaptor: 289mm

Min: 130mm

With air return handle

Adaptors



120mm 75mm 45mm 30mm



Air actuated axle jacks

Short chassis

23205 >

Capacity:	20 Ton
Max with adaptor:	495mm
Max without adaptor:	395mm
Min:	260mm

With extension screw
(see dimension D in table)



with air return

With extension screw



With extension screw



< 23211

Model: 23211

Capacity:	20 Ton
Max with adaptor:	541mm
Max without adaptor:	441mm
Min:	215mm

Adaptors



23207 telescopic >

Capacity:	20 / 35 Ton
Max with adaptor:	454mm
Max without adaptor:	334mm
Min:	186mm

Adaptors



Air actuated axle jacks

High tonnage

< High tonnage - Short chassis

Model: 23301C - 23501 - 23991

Capacity: 30 ton - 50 ton - 100 ton

- Compact, low profile design for maximum access, which fits easily and safely between wheels of tandem axle vehicle.
- User friendly, self-returning spring minimizes operator's effort, greatly reducing fatigue.
- An inline air filter traps contamination and protects air motor for longer life.
- 8-14 BAR suggested air pressure for optimal performance.



Adaptors



45mm

100mm



100mm

200mm

< Air actuated axle jacks

Model: 24301 - 24601

24301

Capacity: 30 Ton

Max with adaptor: 772mm

Max without adaptor: 627mm

Min: 360mm

24601

Capacity: 60 Ton

Max with adaptor: 1031mm

Max without adaptor: 731mm

Min: 420mm

Specifications

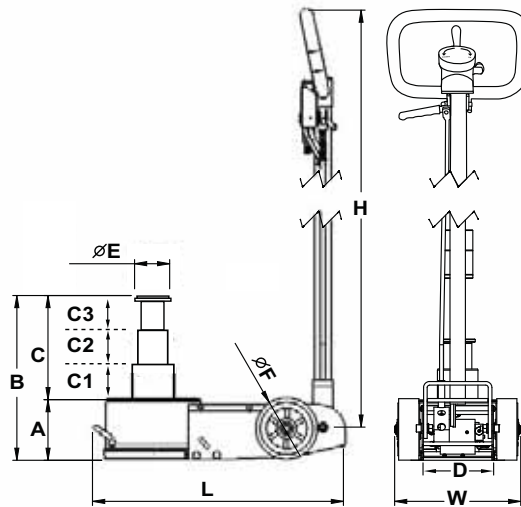



Telescopic - air return

Model	23152	23212	24213	24113	24301/24601
Capacity	15/30 ton	20/40 ton	20/40/60 ton	10/20/40 ton	30 / 60 ton
A (mm)	150	150	150	130	360 / 420
B (mm)	289	289	327	289	627 / 731
Stroke C (mm)	139	139	177	159	267 / 311
C1 (mm)	73	73	57	57	-
C2 (mm)	66	66	59	49	-
C3 (mm)	-	N/A	61	53	-
D (mm)	176	186	215	179	215 / 295
E (mm)	70	70	70	70	70 / 90
F (mm)	65	160	150	125	200 / 200
L (mm)	490	480	875	830	840 / 910
W (mm)	290	290	295	295	282 / 362
H (mm)	500	1430	1510	1510	1380 / 1380
Adaptor 1 (mm)	75	120	120	120	100 / 200
Adaptor 2 (mm)	45	75	75	75	45 / 100
Adaptor 3 (mm)	-	45	45	45	-
Adaptor 4 (mm)	-	30	30	30	-
N.W. (Kg)	24	47	76	50	87 / 126
G.W. (Kg)	30	51	81	56	101 / 143
Pieces Carton	1	1	1	1	1 / 1
CBM/CTN	0.065	0.11	0.17	0.17	0.139 / 0.18
Pcs/20ft Cont.	420	254	175	175	145 / 118

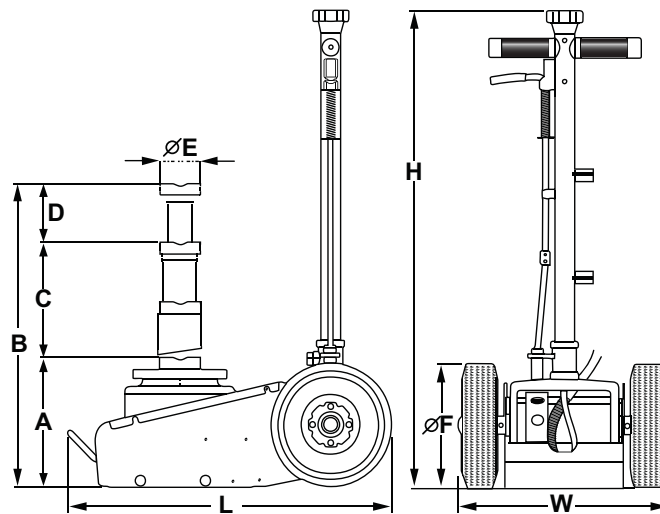
Specifications



	Short Chassis			High Tonnage - Short Chassis		
Model	23205	23211	23207	23301C	23501	23991
Capacity	20 Ton	20 Ton	20/35 Ton	30 Ton	50 Ton	100 Ton

A (mm)	260	215	186	280	305	305
B (mm)	495	441	334	458	483	461
A-B (mm)	235	226	148	-	-	-
Stroke C (mm)	135	141	148	178	178	156
D (mm)	100	85	-	-	-	-
E (mm)	71	43	70	62	79	113
F (mm)	200	165	204	200	204	254
L (mm)	547	525	549	547	549	586
W (mm)	315	265	351	317	351	416
H (mm)	1229	1240	1229	1229	1229	1258
Adaptor 1 (mm)	-	100	120	-	-	-
Adaptor 2 (mm)	-	50	70	-	-	-
Adaptor 3 (mm)	-	20	10	-	-	-
Adaptor 4 (mm)	-	-	-	-	-	-
 N.W. (Kg)	33.4	30	49.5	43.5	72.3	112.5
 G.W. (Kg)	35.4	35	53.2	45.6	83.0	123.3
Pieces Carton	1	1	1	1	1	1
CBM/CTN	0.091	0.083	0.083	0.081	0.119	0.139
Pcs/20ft Cont.	290	320	325	255	216	145

Stabilisation blocks



< SB 001B & SB 001Y

Stabilisation block

- The stabilisation blocks are designed to provide superior crib stability compared to standard products.
- Unlike wooden products, the stabilisation blocks do not splinter or absorb fluids, neither will fail catastrophically.
- Lightweight and easy to handle, with anti-slip layers.
- Instead of snapping, cracking or collapsing it gradually deforms providing a visual warning of overload.

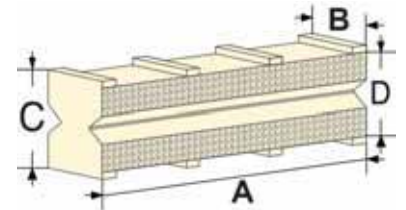

Stabilisation Blocks									
Model	SB 001B		SB 001Y		SB 002B		SB 002Y		
Capacity	35 ton		35 ton		100 ton		100 ton		
	50 ton		50 ton		150 ton		150 ton		
Color	Black		Yellow		Black		Yellow		
Dimension (mm)	457(A) x 90(B)		457(A) x 90(B)		610(A) x 152(B)		610(A) x 152(B)		
	105(C) x 80(D)		105(C) x 80(D)		178(C) x 150(D)		178(C) x 150(D)		
Weight (Kg)	3.2		3.2		11.3		11.3		
Layer	1	4	7	10	1	4	7	10	
Height (mm)	105	345	585	825	175	625	1075	1525	

Wedge for SB 001 or SB 002



Model	SW 001B	SW 002B
Color	Black	Black
Dimension(mm)	490 x 90 x 90	610 x 130 x 145
Weight(Kg)	1.8	5.5

Interlocking
Cribbing Options

Height of the stability tower is limited to
 $\leq 3x$ width of the base.

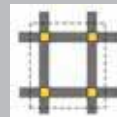

2 Stage

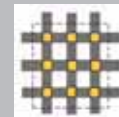

3 Stage



In this photo, we see SB 002B blocks set up for a 2 stage crib application.



Stabilisation blocks are designed according to a system of interlocking blocks. In this photo, we see SB 002B blocks set up for a 3 stage crib application.

Support pads

SP 44410 >

Support pad

- The support pads are outrigger pads used for mobile cranes, truck mounted cranes, aerial working platforms, concrete pumps, containers, hydraulic jacks etc.
- Its purpose is to spread the weight over a larger surface offering better support while also protecting the surface.



Support Pads					
Model	SP 44410	SP 55410	SP 66420	SP 66625	SP 1010650
Capacity	10 ton	15 ton	20 ton	25 ton	50 ton
Grip	1	1	1	1	2
Dimension(mm)	400 x 400 x 40	500 x 500 x 40	600 x 600 x 40	600 x 600 x 60	1000 x 1000 x 60
Weight(Kg)	6	9	14	20	58

Other sizes/capacities available on request.

Support Pads >

- Ecological
- Light weight
- Easy to handle
- High durability
- High flexibility
- Water-repellent
- Nearly unbreakable
- No rusting
- No Rotting



Jack stands

tubing & Ratchet

Jack stands *tubing* >

Model: 3203100 | 3 Ton | Max 433mm / Min 290mm
3206100 | 6 Ton | Max 565mm / Min 365mm
3212100 | 12 Ton | Max 750mm / Min 485mm
3220100 | 20 Ton | Max 923mm / Min 568mm

- Adjustable in various heights.
- Chained lock pin to secure ratchet column.

Sold and to be used only in pairs!



3 & 6 Ton with
rubber pad



< Jack stands *ratchet*

Model: 3203500 | 3 Ton | Max 432mm / Min 292mm
3206500 | 6 Ton | Max 618mm / Min 390mm
3212500 | 12 Ton | Max 700mm / Min 445mm

- One piece, FCD-40 ductile iron ratchet bar provides super strength and durability.
- Quick adjustment ratchet mechanism.

Sold and to be used only in pairs!

Axle stands & High stands

Heavy Duty

3207500 >

Capacity: 7 Ton | Max 360mm / Min 238.5mm

- Special for forklift trucks.

Sold and to be used only in pairs!



< 3222500

Capacity: 22 Ton | Max 505mm / Min 310mm

Sold and to be used only in pairs!



< 3210901

Capacity: 10 Ton | Max 1194mm / Min 711mm

Sold and to be used only in pairs!



with rubber pad

3203900 >

Capacity: 3 Ton | Max 2000mm / Min 1300mm

Sold per piece!

Specifications

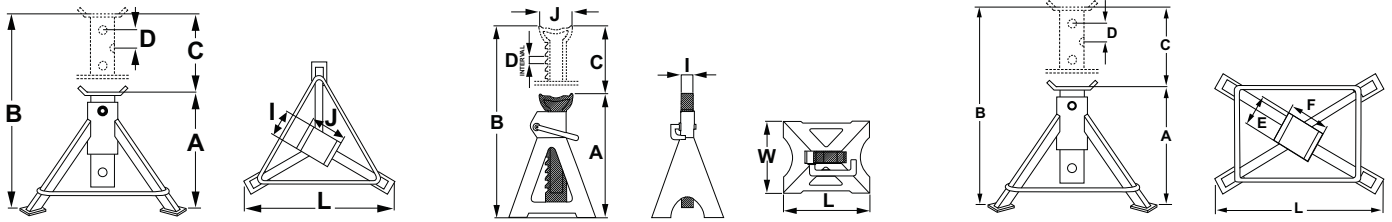

Model Capacity	Tubing				Ratchet		
	3203100	3206100	3212100	3220100	3203500	3206500	3212500
Capacity	3 ton	6 ton	12 ton	20 ton	3 ton	6 ton	12 ton
A (mm)	294	375	481	568	292	390	445
B (mm)	437	575	752	923	432	618	700
C (mm)	143	200	265	355	140	228	255
D (mm)	29	40	53	79	15	18	23
I (mm)	60	80	90	80	27	31	37
J (mm)	75	80	90	90	90	110	120
L (mm)	121	339	389	524	190	270	307
W (mm)	-	-	-	-	170	235	274
N.W. (Kg)	5.2	10.6	23.5	34.4	6.0	13.7	24.5
G.W. (Kg)	5.5	12.0	25.5	38.5	6.4	14.5	25.8
Pieces Carton	1	1	1	1	1	1	1
CBM/CTN	0.020	0.047	0.073	0.169	0.016	0.038	0.063
Pcs/20ft Cont.	1343	600	336	172	1760	708	415

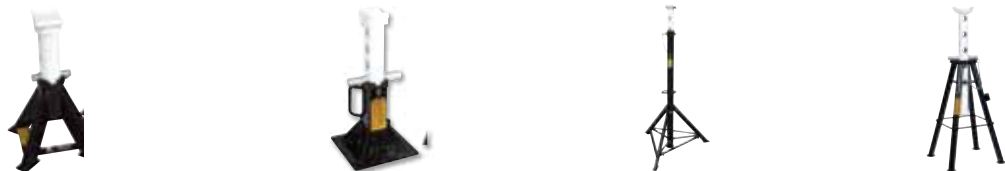

Model Capacity	Heavy Duty			
	3207500	3222500	3203900	3210901
Capacity	7 ton	22 ton	3 ton	10 ton
A (mm)	238.5	310	1300	711
B (mm)	360	505	2000	1194
C (mm)	121.5	195	700	483
D (mm)	55	55	50	50
E (mm)	64	70	80	80
F (mm)	90	80	110	125
G (mm)	-	-	-	-
L (mm)	220	250	837	407
W (mm)	-	-	-	-
H (mm)	-	-	-	-
N.W. (Kg)	9.6	27.8	21.9	50.0
G.W. (Kg)	11.1	28.8	24.3	54.2
Pieces Carton	1	1	1	1
CBM/CTN	0.023	0.034	0.059	0.228
Pcs/20ft Cont.	1152	832	429	120

Hydraulic pit jack

Magic lift



< Pit jack

Model: 46030 | 300kg | max 2105mm / min 1280mm
 46060 | 600kg | max 2097mm / min 1267mm
 46100 | 1000kg | max 2146mm / min 1316mm

- Magic lift hydraulic unit reaches the desired height twice as fast as traditional models without magic lift.
- By turning the saddle upside down, it can also be used as extra support.



Reversible



Saddle

art. 21030-04



Saddle pad

art. 2903509100



Transmission Saddle

41901 (optional for the 46100)



Transmission Saddle

S0501T (optional for the 46030)



	Magic lift		
Model	46030	46060	46100
Capacity	300 kg	600 kg	1000 kg
A (mm)	1280	1267	1316
B (mm)	2105	2097	2146
C (mm)	825	830	830
D (mm)	100	100	100
E (mm)	900	873	931
F (mm)	76	76	125
G (mm)	435	435	435
L (mm)	575	575	720
W (mm)	600	600	640
H (mm)	1052	1028	1086
N.W. (Kg)	31.0	36.3	43.9
G.W. (Kg)	34.1	39.4	49.4
Pieces Carton	1	1	1
CBM/CTN	0.0971	0.0971	0.103
Pcs/20ft Cont.	270	270	210

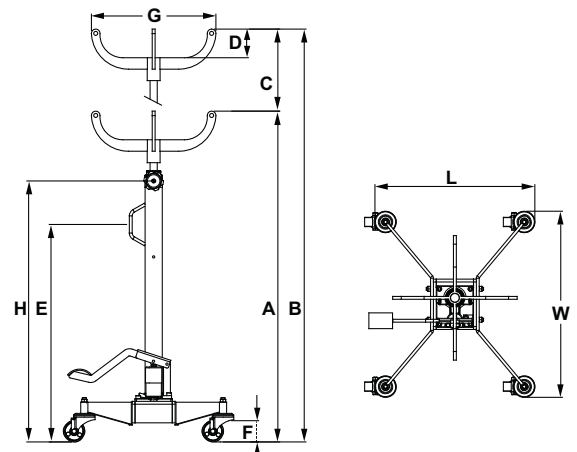

Transmission jacks

Heavy duty



< 41000C

Model: 41000C - Manual

41001 - Air Operated

Capacity: 500kg | max 2026mm / min 1016mm

- Effortless air operation will greatly reduce operator's fatigue and speed up the efficiency of garage work.
- 8-14 BAR suggested air pressure for optimal performance.

42001 >

Single stage air operated

Capacity: 1000kg | max 2163mm / min 1433mm

- Effortless air operation will greatly reduce operator's fatigue and speed up the efficiency of garage work.
- 8-14 BAR suggested air pressure for optimal performance.



< 4200000

Model: 41100C | 500kg | max 630mm / min 343mm

4200000 | 1000kg | max 850mm / min 320mm

- Load-restraining chain for safety.
- Head adjustable in all directions for optimal alignment of transmission bolt patterns and pins.
- Rugged steel wheels and full swivel ball bearing casters.
- Multi-adjustment knobs ensure that transmission cradle is always at the right angle to position and accept any load.

Transmission jacks

Heavy duty



< 43000

Capacity: 1500 KG | max 1195mm / min 450mm

- Load-restraining chain for safety.
- Head adjustable in all directions for optimal alignment of transmission bolt patterns and pins.
- Rugged steel wheels and full swivel ball bearing casters.
- Multi-adjustment knobs ensure that transmission cradle is always at the right angle to position and accept any load.

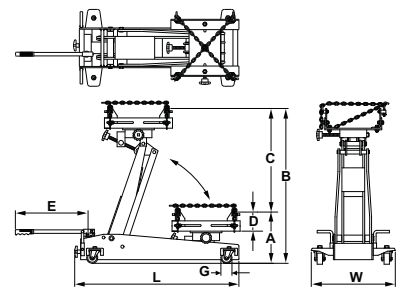
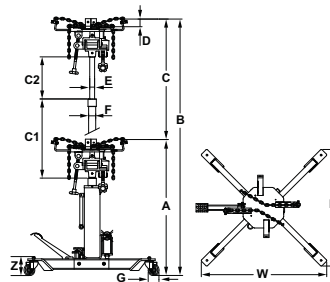

	Heavy duty					
	41000C	41001	42001	41100C	4200000	43000
Model	41000C	41001	42001	41100C	4200000	43000
Capacity	500 kg	500 kg	1000 kg	500 kg	1000 kg	1500 kg
A (mm)	1016	1016	1433	343	320	450
B (mm)	2026	2026	2163	630	850	1195
C (mm)	1010	1010	730	400	650	745
C1 (mm)	490	490	-	-	-	-
C2 (mm)	520	520	-	-	-	-
D (mm)	55	55	198	114	120	250
E (mm)	35	35	45	570	570	740
F (mm)	47	47	-	-	-	-
G (mm)	79	79	100	58	73	100
L (mm)	840	840	1002	790	1038	1188
W (mm)	903	903	1069	380	485	650
N.W. (Kg)	73.5	81.5	130.0	43.0	84.8	133.5
G.W. (Kg)	81.8	89.8	143.8	48.2	91.0	147.8
Pieces Carton	1	1	1	1	1	1
CBM/CTN	0.175	0.175	0.246	0.105	0.130	0.231
Pcs/20ft Cont.	170	170	85	224	184	104

Body Repair Kits

Heavy Duty



< 50040

Capacity: 4 Ton

- Sets are portable for easy usage in shop or on the road.
- Designed for applications such as pushing, spreading and pressing of vehicle body panels as well as various component parts and assemblies.

Length extension bars:

50040 (mm)	50100 (mm)
495	685
420	455
215	255
155	105
75	



Flat base



Rubber head



Ram toe



Wedged head



Hose



Plunger toe



Combi head



Serrated saddle



Male connector



Spreader



Specifications for the pumps & rams see page 47

50100 >

Capacity: 10 Ton

- Sets are portable for easy usage in shop or on the road.
- Designed for applications such as pushing, spreading and pressing of vehicle body panels as well as various component parts and assemblies.
- Handy tubing storage compartment design.
- With wheels



Engine cranes

Foldable

44012 >

Capacity: 1000 KG

- **Foldable cranes**

Unique folding design for easy, fast and compact storage.

- HTR (Hold-To-Run) mechanism, designed to assure user's maximum safety when the valve is released.

Equalizer optional 90150

680 kg capacity



Equalizer optional 90150

680 kg capacity



< 44017

Model: 44017 - 44018

Capacity: 1000 KG

- 44017 with MagicLift hydraulic unit.
- 44017 + 44018, operating handle with 270 degrees swiveling angle.
- HTR (Hold-To-Run) mechanism.



MagicLift™

Engine cranes



< 44020

Capacity: 2000 KG

- Hard chrome plated piston rod.
- Built in safety overload valve.
- Retractable front legs and lifting boom for easy storage.

Equalizer optional 90150

680 kg capacity

Hydraulic long jack >

Models: 44943 - 44947 - 44949 - 44980

- Polished ram plunger and cylinder protect seals from abrasion.
- Built- in safety overload valve.

Model	Hydraulic long jack			
	44943	44947	44949	44980
Capacity	4 Ton	4 Ton	4 Ton	8 Ton
A (mm)	612	605	612	600
B (mm)	1120	1113	1120	1085
C (mm)	508	508	508	485
D (mm)	1137	1130	1137	1099
E (mm)	750	500	500	500
F (mm)	30	30	30	35
G (mm)	16.0	16.0	16.0	18.0
L (mm)	165	130	165	128
W (mm)	130	114	130	120
H (mm)	628	622	628	614
N.W. (Kg)	12.7	9.9	11.4	13.5
G.W. (Kg)	28.2	20.8	25.0	28.3
Pieces Carton	2	2	2	2
CBM/CTN	0.060	0.030	0.050	0.043
Pcs/20ft Cont.	972	1360	1056	1226



*With 270° swivel handle
where indicated*

Specifications

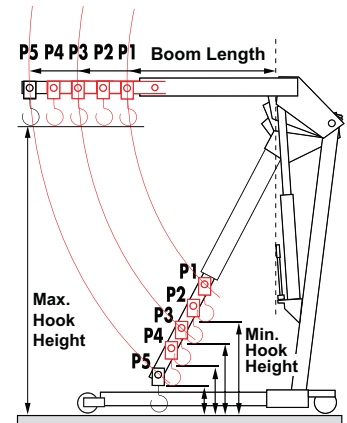
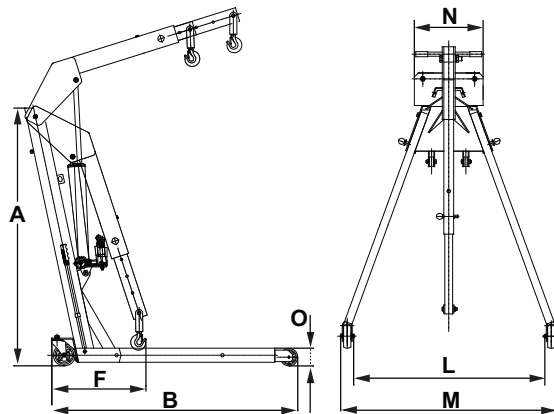

	Foldable			Heavy Duty
	44012	44017	44018	44020
Model	44012	44017	44018	44020
Capacity	1 ton	1 ton	1 ton	2 ton
A (mm)	1330	1460	1460	1394
B (mm)	1540	1525	1525	2305
F (mm)	450	570	570	1725
L (mm)	845	1060	1060	735
M (mm)	1000	1200	1200	860
N (mm)	380	350	350	1350
O (mm)	125	100	100	89
N.W. (Kg)	73.0	84.0	83.4	105.0
G.W. (Kg)	80.0	94.0	90.6	110.5
Pieces Carton	1	1	1	1Pc = 2Carton
Wheels	Metal	PU	PU	Metal
Lifting Arm Position	4	5	5	4
Operating Swivel Handle	-	270°	270°	-
HTR (hold to run)	Yes	Yes	Yes	Yes
Magic Lift	No	Yes	No	No

	44012				44017 & 44018					44020			
	P1	P2	P3	P4	P1	P2	P3	P4	P5	P1	P2	P3	P4
Lock position of extension boom													
Capacity	1000	850	700	550	1000	900	800	700	600	2000	1500	1000	500
Minimum hook height (mm)	280	200	125	50	439	341	243	145	0	465	355	235	127
Maximum hook height (mm)	2070	2140	2205	2280	1978	2021	2075	2131	2170	1760	1910	2065	2200
Boom Length (mm)	710	795	870	950	620	720	820	920	1020	1238	1465	1692	1919

Engine Stands & Supports

Heavy Duty

31000 >

Engine stand
Capacity: 500 KG

- Head plate locks in 8 positions and rotates 360°.



90068 ^

1 spindle
Capacity: 300 KG

- Feet and spindles are adjustable over the whole length of the support.



NEW

Ball bearing makes turning the spindle easier



90165 v

2 spindles
Capacity: 500 KG

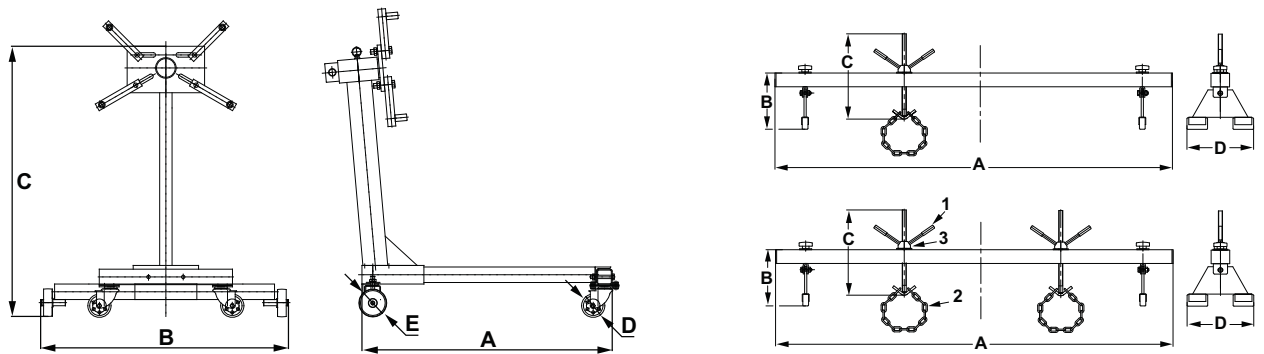

Specifications



	Engine Stand	Supports	
Model	31000	90068	90165
Capacity	500 Kg	300 Kg	500 Kg
A (mm)	808	1500	1650
B (mm)	800	205	205
C (mm)	878	310	310
D (mm)	75	243	243
E (mm)	89	-	-
Saddle Base	250x150	-	-
Min. Claw Area	292x122	-	-
Max. Claw Area	402x152	-	-
 N.W. (Kg)	23.0	12.5	16.0
 G.W. (Kg)	25.4	13.5	17.5
Pieces Carton	1	1	1
CBM/CTN	0.043	0.023	0.027
Pcs/20ft Cont.	700	1250	1000

Presses

Heavy duty

Presses >

Model: 61154 - 61204 - 61304 - 61504

Capacity: 15 - 20 - 30 - 50 Ton

- Excellent for bending, bonding or straightening applications.
- Multi-position bed for work height adjustment (A-B)
- Press bed of 50 Ton press moved by Winch.
- Double speed pumps for fast ram moving without load.
- Cylinder can be re-positioned in width (M).
- Gauge indicates metric Tons.

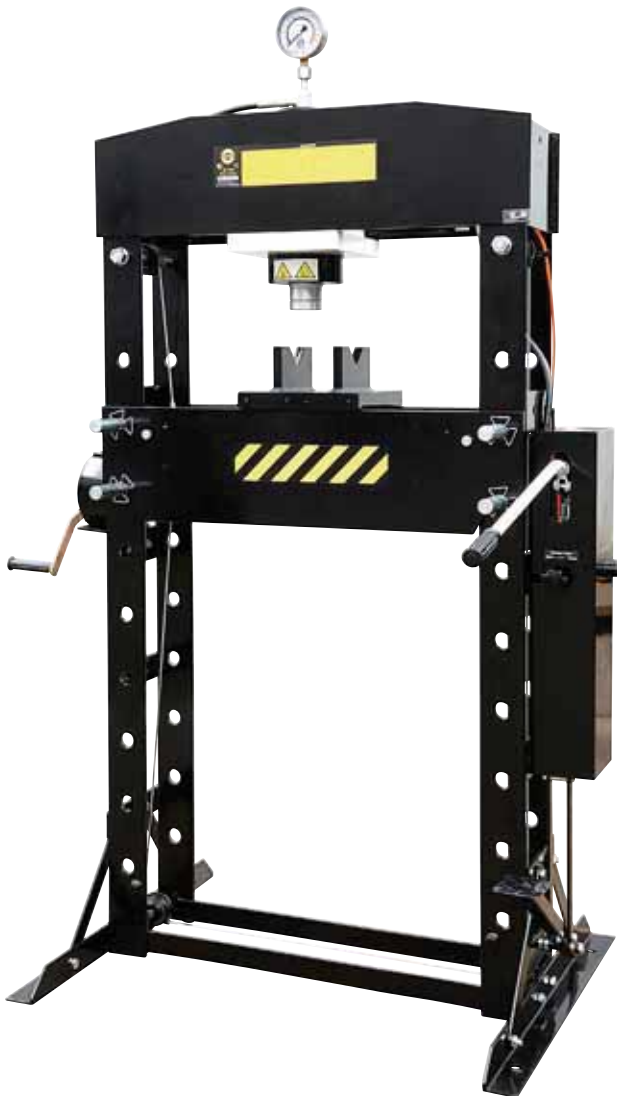

< 61504

Capacity: 50 Ton



Handwinch

61025 >

Punch set

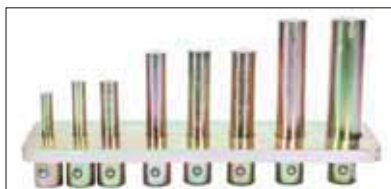

Specifications

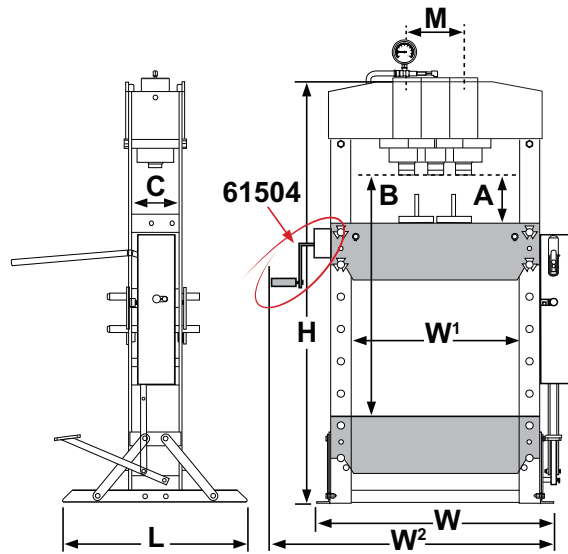

Presses

Model	61154	61204	61304	61504
Capacity	15 ton	20 ton	30 ton	50 ton
Stroke	160	185	160	200
A (mm)	168	35	151	69
B (mm)	980	912	1031	1048
C (mm)	160	176	200	245
M (mm)	160	176	200	245
L (mm)	540	540	700	800
W (mm)	700	730	795	1030
W1 (mm)	500	510	535	730
W2 (mm)	-	-	-	748
H (mm)	1727	1713	1772	1830
N.W. (Kg)	91.5	112	166.7	298
G.W. (Kg)	118.5	139	202.7	340.6
Pieces Carton	1	1	1	1
CBM/CTN	0.299	0.331	0.404	0.607
Pcs/20ft Cont.	56	56	56	56



Gauge



Arbor plate



Manual operation



Foot operation

Bench & Shop presses

Heavy duty



< **65124**

Capacity: 12 Ton

Optional:

Gauge adaptor: 60153-50 (GBW1460)

Fitting: 434-4-0000-000

60253 >

Capacity: 25 Ton



Specifications

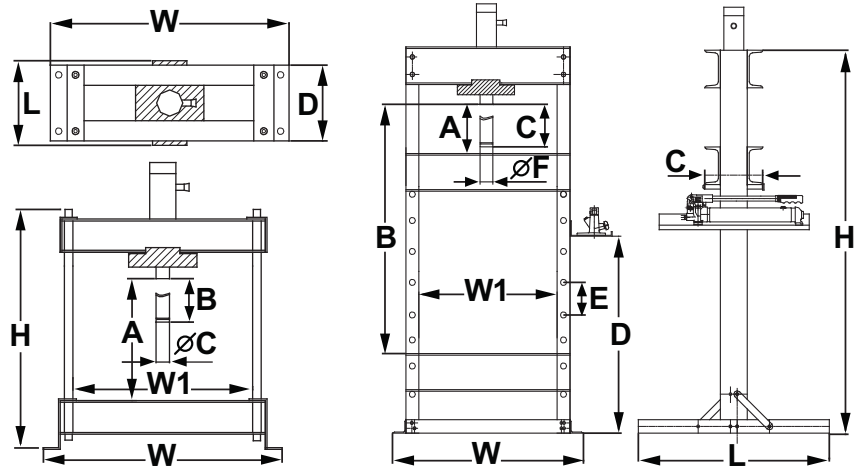

Presses

Model	65124	60253
Capacity	12 ton	25 ton
Stroke	153,5	165
A (mm)	378,5	63,5
B (mm)	153,6	869
C (mm)	33,3	165
D (mm)	175	800
E (mm)	-	115
F (mm)	-	57
G (mm)	-	219
H (mm)	725	1495
L (mm)	175	710
W (mm)	550	710
W1 (mm)	365	510
N.W. (Kg)	49,1	119,2
G.W. (Kg)	55,7	123,8
Pieces Carton	1	2
CBM/CTN	0,052	0,086
Pcs/20ft Cont.	320	156



Bearing punch 60253



Arbor plate 60253



Gauge 60253
65124 (optional!)



Gauge adaptor + Fitting
65124 (optional!)

Wheel arm & pipe bender

9210000 >

EZ wheel arm

The EZ Wheel Arm is a great accessory to hold tyres on a vehicle lift arm. With the adjustable design, it can easily be used on lift arms of various thickness. The bar can be folded up or sideways when not in use to save space.

Supplied in pairs

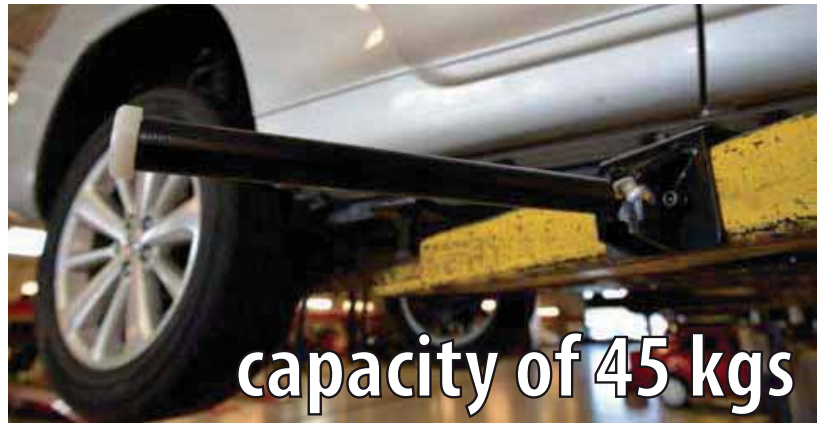

Min width 79 mm
Max width 142 mm

Min height 76 mm
Max height 123 mm

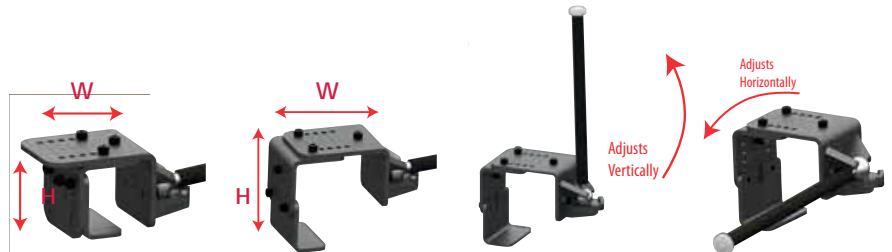

< 6615000

Pipe Bender

Capacity: 15 Ton

- Complete with 8 former attachments for a wide variety of pipe diameters.
- Capable of bending high pressure/temperature tubing as well as standard hydraulic, gas, steel, aluminum and brass from 12.7mm up to 76,2mm with included attachments.

Specifications:

Cylinder capacity:	15 Ton
Ram range:	251mm
Max. working pressure:	700 BAR
Product size:	770x779x970mm
G.W.:	82.8 Kg



12,7mm 19,1mm 25,4mm 31,8mm 38,1mm 50,8mm 64mm 76,2mm

Car dolly set

47020 >

Capacity: 900 Kg per dolly

Can support the vehicle in three different ways:

- By the wheel
- By the pinch weld
- By the frame



- No adapters required
- Integrated frame adapters
- Locking casters
- No tools required
- Adapter secured with pins
- Easily stacked for convenient storage
- Sold in pairs of two



Tyre handling equipment

90250 >

Move Jack

Capacity: 680 Kg

- Ideal for manoeuvring cars in shops and showrooms.
- Rigid steel frame - 680 Kg capacity per jack, 2720 Kg capacity per 4 jacks set.
- Handles tyres up to 12" - 305mm wide.
- Easy foot-pedal operation.

2 jacks: allow full 180° vehicle pivot.

4 jacks: place vehicle on 360° rolling platform.

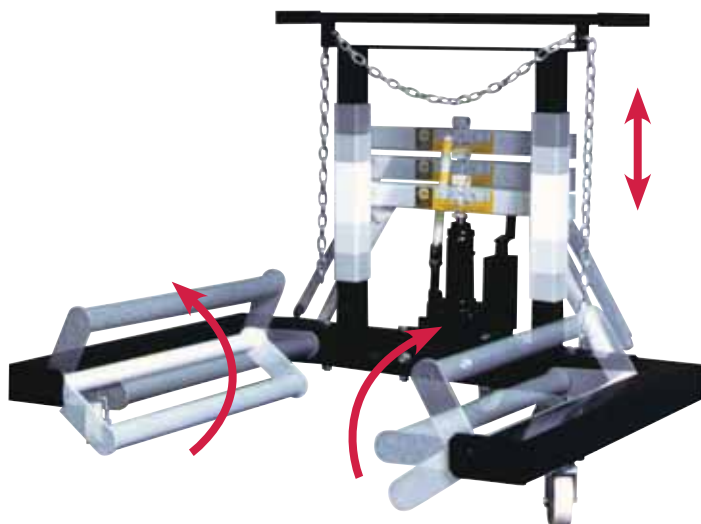

< 47053

Wheel Dolly

Capacity: 680 Kg

- Hydraulic system actuated to provide smooth, positive power for the removal and installation of single, tandem and duplex tyres and wheels.
- Adjustable cradle rollers and lifting height.

22910 >

Bead Breaker

Capacity: 5 Ton

- For single rimmed wheels, with a maximum rim size of 25".
- Oil capacity 250cc.



Specifications

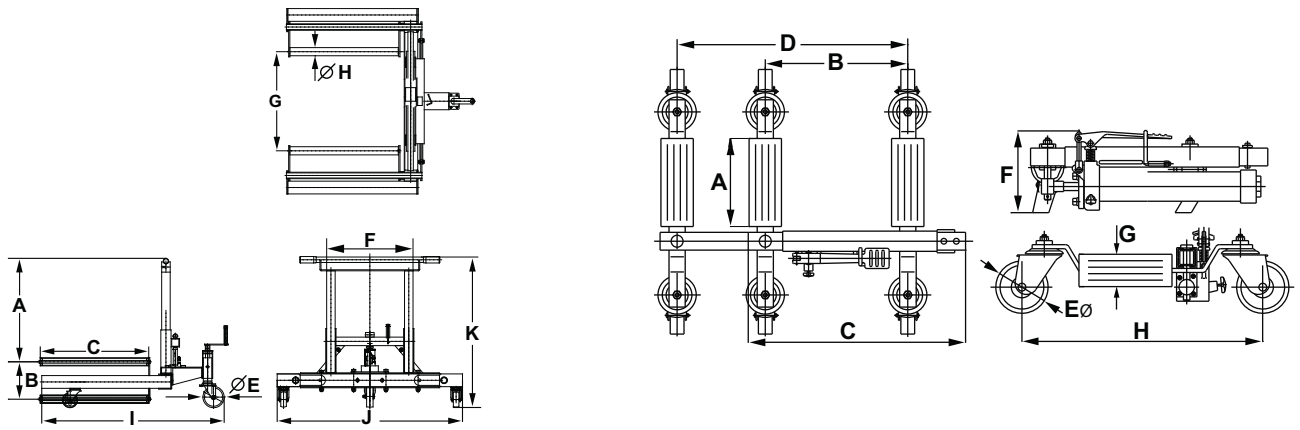

	Wheel Dolly	Move Jack	Car Dolly	Bead Breaker
Model	47053	90250	47020	22910
Capacity	680 Kg	680 Kg	900 Kg	5 ton
A (mm)	609	305	352	397
B (mm)	220	345	458	-
C (mm)	638	540	515	131.5
D (mm)	-	625	187	73
E (mm)	125	102	-	55
F (mm)	508	190	380	230
G (mm)	583	68	190	330
H (mm)	48	560	60	20
I (mm)	1073	-	101	95
J (mm)	1090	-	-	38
K (mm)	883	-	-	138
L (mm)	-	-	-	100
N.W. (Kg)	68.0	35	36.2	14.0
G.W. (Kg)	72.2	40	38	16.4
Pieces Carton	1	2	2	1
CBM/CTN	0.129	0.134	280	0.022
Pcs/20ft Cont.	144	400	560	1125

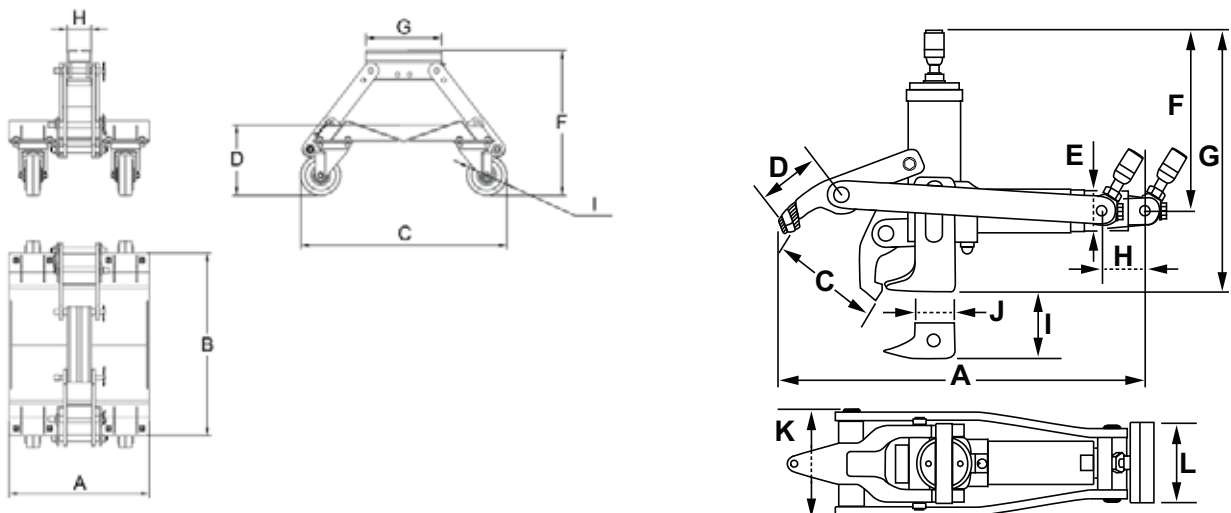

Pumps & Cylinders

Heavy duty

Hydraulic hand pumps >

Model: 55040 - 55100

Capacity: 270cc / 700 BAR - 770cc / 700 BAR

- Built-in safety overload valve.



< Air actuated treadle pump

Model: 22903

Capacity: 1500cc / 700 BAR

- Built-in safety overload valve.
- Durable lightweight aluminum reservoir.
- Foot pedal provides hand-free user-friendly operation.

Hydraulic cylinders >

Model: 55049 - 55109

Capacity: 4 Ton - 10 Ton

- Internal plunger wipers help seal out dirt and a guide ring is designed to protect against side load damage.
- Industrial hard chrome-plated ram helps to prevent rust and corrosion.
- Maximum working pressure: 700 BAR / 10000psi.

55049

Also included in the auto-body repair-kit 50040. (page 34)

55109

Also included in the auto-body repair-kit 50100. (page 34)



< Pull cylinders

Model: 71055 - 71105

Capacity: 5 Ton - 10 Ton

Specifications

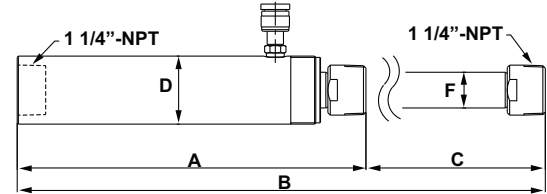
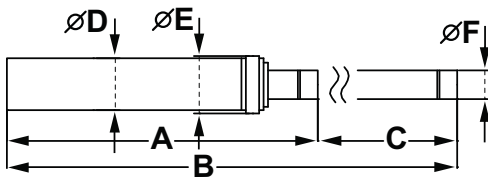
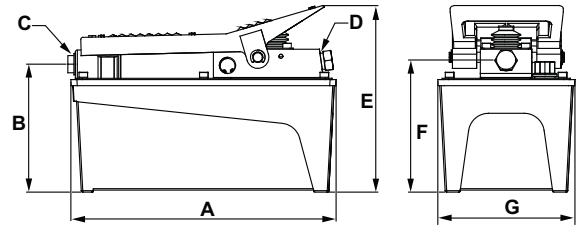
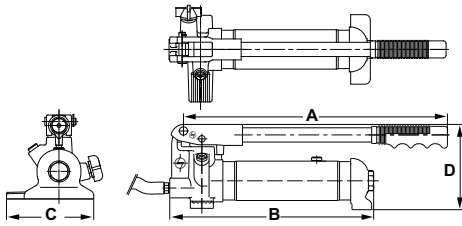

Model	Hydraulic pumps		Foot pump	Hydraulic cylinders		Pull Cylinders	
	55040	55100	22903	55049	55109	71055	71105
Capacity	700 BAR	700 BAR	700 BAR	4 Ton	10 Ton	5 Ton	10 Ton
Oil Capacity (cc)	270	770	1500	100	290	106	236
A (mm)	400	480	263	274	348	294	290
B (mm)	310	500	126	397	502	435	440
C (mm)	147	147	1/4" NPTF-18	123	154	141	150
D (mm)	130	130	3/8" NPTF-18	38	58	58	70
E (mm)	-	-	185	44	66	-	-
F (mm)	-	-	130	25	41	32	32
G (mm)	-	-	136	-	-	-	-
Weight (Kg)	-	-	8.2	-	-	-	-
N.W. (Kg)	6.1	7.2	-	1.8	4.9	3.8	5.5
G.W. (Kg)	6.6	7.8	-	8.6	5.1	8.6	12.0
Pieces Carton	1	1	-	1	1	2	2
CBM/CTN	0.014	0.020	-	0.001	0.004	0.007	0.008
Pcs/20ft Cont.	1980	1320	-	8780	3529	3456	3000
Hose Length (mm)	13x1818	13x1818	-	-	-	-	-
Coupler	1/4" NPTF-18	1/4" NPTF-18	-	-	-	1/4" NPTF	1/4" NPTF
Pressure Rating (BAR)	-	-	700	-	-	700	700
Output Flow Rate (cm ³ / min)							
No Load	-	-	1075	-	-	-	-
Load	-	-	180	-	-	-	-
Air pressure range (BAR)	-	-	7-14	-	-	-	-

Lifting equipment



Pro-Lift

Bottle jacks	Page 52
Floor jacks	Page 53
Garage jacks	Page 54
Specifications	Page 55
Jacks stands	Page 56
Lawn mower lift	Page 57
Engine crane & body repair kit	Page 58
Pit jack	Page 59

Bottle jacks

- Steel lifting saddle created for load gripping power.
- Extension screw adjusts to accommodate work height.
- Patented bypass device protects against over-pumping.
- Heat treated critical stress areas ensure long life performance.
- Meets or exceeds CE & ANSI/PALD standards.
- Ideal for auto, truck service, farm and shop use.

B0200 >

Bottle Jack - 2 Ton

B0200: 95mmx95mmx183mm (LxWxH)

Lifting Range: 183-348mm

Packing specification:

Carton: 6 - Length: 340mm - Wide: 230mm - Height: 220mm -
N.W.(Kgs): 2.9 - G.W.(Kgs): 18.3 - CBM: 0.017



< B0400

Bottle Jack - 4 Ton

B0400: 107mmx99mmx204mm (LxWxH)

Lifting Range: 204-391mm

Packing specification:

Carton: 6 - Length: 410mm - Wide: 250mm - Height: 250mm -
N.W.(Kgs): 4 - G.W.(Kgs): 25.3 - CBM: 0.026

B0600 >

Bottle Jack - 6 Ton

B0600: 115mmx102mmx219mm (LxWxH)

Lifting Range: 219-427mm

Packing specification:

Carton: 4 - Length: 270mm - Wide: 240mm - Height: 273mm -
N.W.(Kgs): 5.2 - G.W.(Kgs): 21.8 - CBM: 0.018



Floor jacks

< F2000

Floor jack - 2 Ton

F2000: 504mmx201mmx104mm (LxWxH)

Lifting Range: 140-356mm

F2000 B v

Floor jack in blow mold case - 2 Ton



F7670 >

Low Profile - 2 Ton

F777: 560mmx212mmx85mm (LxWxH)

Lifting Range: 85-373mm



< F5210

Floor jack extra high (SUV) lift - 2.25 Ton

F5210: 719mmx249mmx150mm (LxWxH)

Lifting Range: 150-533mm



Garage jacks

G1250 >

Low profile aluminium garage jack - 1.25 Ton

G2500: 553mmx238mmx89mm (LxWxH)

Lifting range: 89-354mm

- Double Piston.
- Universal Joint.
- Bypass System to prevent overloading and over-pumping.
- Compactly Build.
- Including Saddle Pad.



< G2500

Low profile garage jack - 2.5 Ton

G2500: 650mmx340mmx85mm (LxWxH)

Lifting range: 85-480mm

- Double Piston.
- Universal Joint.
- Bypass System to prevent overloading and over-pumping.
- Compactly Build.
- Including Saddle Pad.



G2250 >

Garage Jack - 2.25 Ton.

G2250: 644mmx335mmx165mm (LxWxH)

Lifting Range: 135-495mm

- Gear type
- Bypass System to prevent overloading and over-pumping.
- Compactly Build.



< G3002

Garage Jack - 3 Ton

G3002: 672mmx334mmx120mm (LxWxH)

Lifting Range: 120-480mm





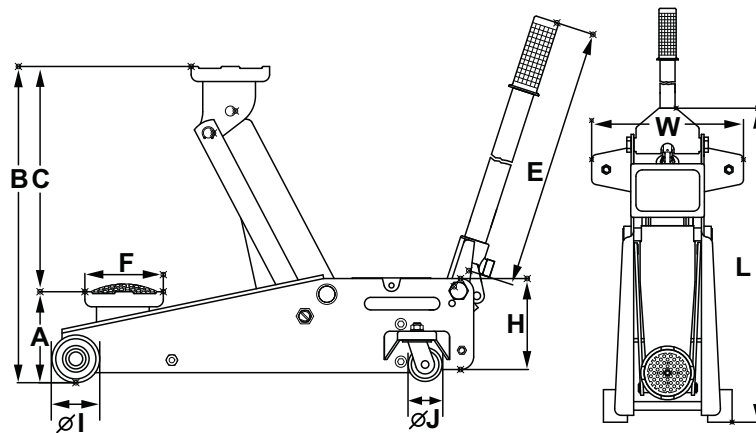

- Double Piston.
- Universal Joint.
- Bypass System to prevent overloading and over-pumping.
- Compactly Build.
- Including Saddle Pad.



Specifications



Hydraulic service jacks

Model	F2000	F7670	F5210	G1250	G2500	G2250	G3002
Capacity	2 ton	2 ton	2.25 ton	1.25 ton	2.5 ton	2.25 ton	3 ton
A (mm)	135	85	150	89	85	135	120
B (mm)	350	373	533	354	490	495	460
Stroke C (mm)	220	288	383	265	410	360	340
E (mm)	500	500	620	946	1070	1100	1150
F (mm)	48	60	60	100	110	110	110
I (mm)	60	65	75	50	72	90	80
J (mm)	35	40	50	40	43	50	58
L (mm)	490	560	719	553	704	740	672
W (mm)	210	212	250	238	334	345	334
H (mm)	115	145	125	142	151	140	162
 N.W. (Kg)	10.2	13.3	19.4	15	31.5	30.2	32
 G.W. (Kg)	11	14	21	16.3	33	31.5	34.2
Pieces Carton	1	1	1	1	1	1	1
CBM/CTN	0.018	0.025	0.036	0.030	0.060	0.054	0.049
Pcs/20ft Cont.	x	x	x	x	x	x	x
 Soft Saddle-Pad	-	-	-	x	x	-	x
 Universal Joint	-	-	-	x	x	-	x
 Air vent valve or oil filter plug	-	-	-	-	-	-	-
 Wheels	Metal	Metal	Metal	Metal	Metal	Metal	Metal

Jack stands

- High quality cast ductile iron ratchet bar.
- Ideal for auto, truck service, farm and shop use.
- Height adjustment mechanism allows smooth upward movement while release handle locks into position.
- Meets or exceeds ANSI/PALD standards.
- Sturdy stamped steel construction.

T3004 >

Jack Stands Ratchet (Extra High) - 2.25 Ton

T3004: 215mmx170mmx340mm (LxWxH)

Lifting Range: 340-535mm

Packing specification:

Carton: 1 - Length: 305mm - Wide: 245mm - Height: 320mm -
N.W.(Kgs): 6.6 - G.W.(Kgs): 7.6 - CBM: 0.024



< T3003

Jack Stands Ratchet - 2.8 Ton

T3003: 208mmx180mmx284mm (LxWxH)

Lifting Range: 305-450mm

Packing specification:

Carton: 1 - Length: 318mm - Wide: 230mm - Height: 280mm -
N.W.(Kgs): 6.6 - G.W.(Kgs): 7.4 - CBM: 0.017



T2002 >

Jack stands foldable - 2 Ton

G2002: 250mmx250mmx249mm (LxWxH)

Lifting Range: 280-355mm

Packing specification:

Carton: 6 - Length: 514mm - Wide: 200mm - Height: 295mm -
N.W.(Kgs): 21.4 - G.W.(Kgs): 22.8 - CBM: 0.030



Lawn mower lift

T5350B >

Lawn mower lift

Capacity: 155 Kg

Lift height: 508mm

Weight: 36,5 Kg

Compatible wheel track: 116,8cm - 129,5cm outside span

- Perform necessary mower maintenance
- Easy, convenient hydraulically powered foot pedal operation
- Rubber coated saddle to prevent unwanted movement
- Welded solid steel construction
- Positive dual locking safety latch for added safety
- Four steel wheels for sturdy mobility
- Patent pending
- Extra side brackets for more stability

Packing specification:

Carton: 1 - Length: 1110mm - Wide: 440mm - Height: 210mm -

N.W.(Kgs): 36.5 - G.W.(Kgs): 40 - CBM: 0.104



Engine crane & body repair kit

- Polished ram plunger and cylinder protects seals from abrasion.
- Foldable model with retractable front legs and lifting boom for easy storage.
- Built-in safety valve ensures operator's safety against overloading.
- Heavy duty welded construction with rugged reinforced tubular steel.



< C1001

Foldable Engine Crane

C1001: 1540mm x 1000mm x 1330mm (LxWxH)

Capacity: 1000 Kg

Lifting Range: 50-2280mm

Packing specification:

Carton: 1 - Length: 1430mm - Wide: 460mm - Height: 345mm -
N.W.(Kgs): 73.0 - G.W.(Kgs): 80.0 - CBM: 0.226

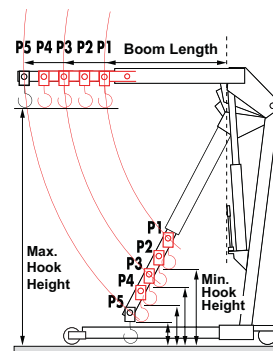

Lock position of extension boom				
Capacity				
Minimum hook height (mm)				
Maximum hook height (mm)				
Boom Length (mm)				
N.W. (Kg)				
G.W. (Kg)				

C1001				
	P1	P2	P3	P4
Capacity	1000	850	700	550
Minimum hook height (mm)	280	200	125	50
Maximum hook height (mm)	2070	2140	2205	2280
Boom Length (mm)	710	795	870	950
N.W. (Kg)		73.0		
G.W. (Kg)		80.0		

Sets are portable for easy usage in shop or on the road. Designed for applications of pushing, spreading and pressing of vehicle body panels as well as various component parts and assemblies.

< A1000

10 Ton Body repair kit



P0501 >

Pit Jack

P0500: 600mm x 600mm x 1100mm (LxWxH)

Capacity: 500 Kg

Lifting Range: 1100-1900mm

HTR (Hold-To-Run) mechanism, designed to assure users' maximum safety when the valve is released.



Transmission Saddle

S0501T

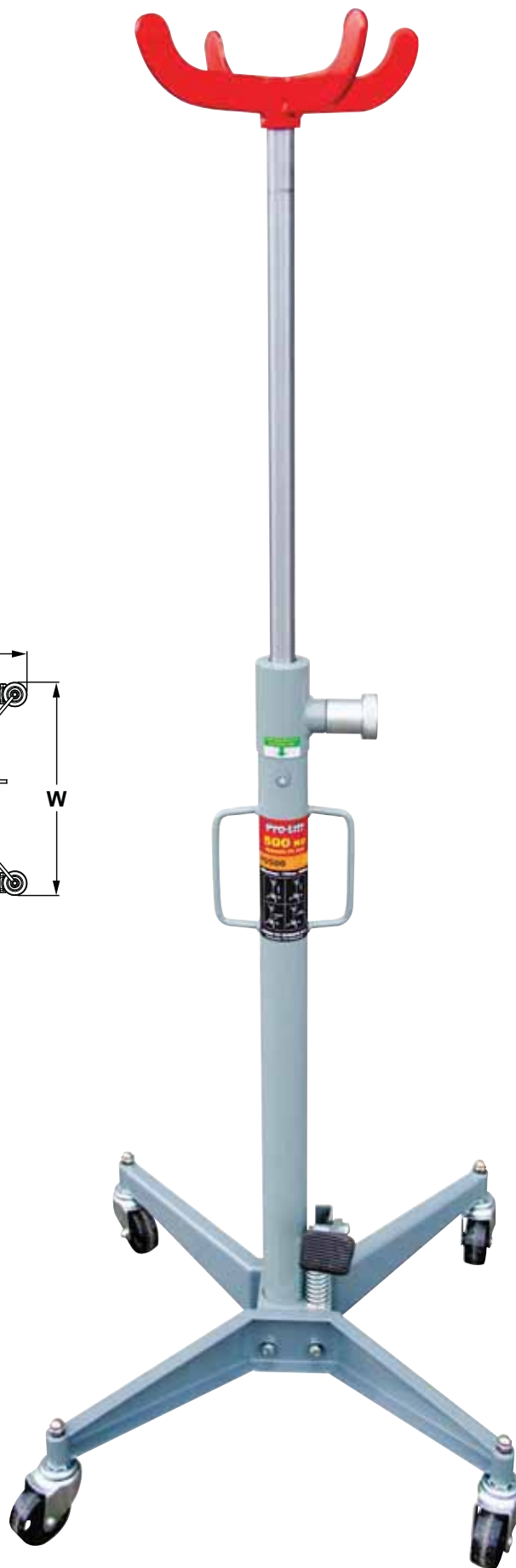
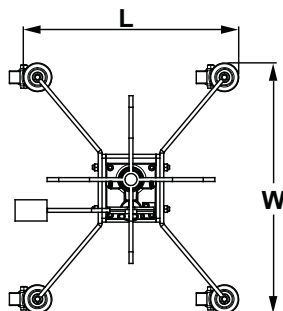
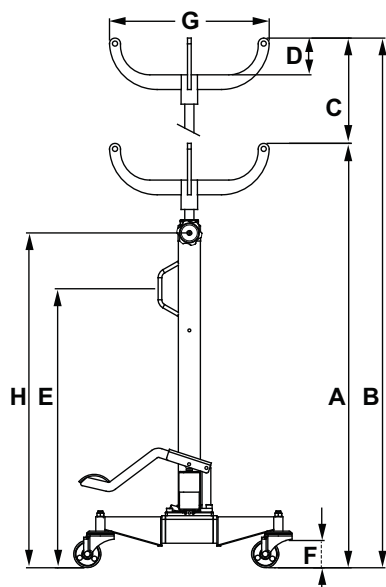

Pit Jack	
Model	P0501
Capacity	500 kg
A (mm)	1100
B (mm)	1900
C (mm)	700
D (mm)	50
E (mm)	775
F (mm)	76
G (mm)	325
L (mm)	600
W (mm)	600
H (mm)	975
N.W. (Kg)	28
G.W. (Kg)	30
Pieces Carton	1
CBM/CTN	0.069
Pcs/20ft Cont.	

Professional hand tools



Tool cabinet & Tool trolley	Page 62 - 65
Modules (sets)	Page 66 - 67
Modules	Page 68 - 73
Socket sets	Page 74 - 79
Tool set	Page 80 - 83
Adaptor sets	Page 84 - 85
Ratchet handles	Page 86
Gear wrench & sets	Page 87 - 89
Combination & Adjustable wrenches	Page 90 - 91
Pliers set & Wire cutters	Page 92 - 93
Screwdrivers	Page 94 - 95
Torque wrenches & Ratchet handles	Page 96 - 97
Air impact wrenches	Page 98 - 100
Cordless Impact wrenches	Page 101
Impact sockets & Adapters	Page 102 - 103
Automotive misc & clutch tools	Page 104 - 106
Bearing driver & Oil filling system	Page 107
Bit sets	Page 108
Rethreading & Locking nut extractor set	Page 109
Pullers & Splitters	Page 110 - 111
Punch, chisel & hex key sets	Page 112
Wrench, Twist drill bits &	
Oil drain plug key set	Page 113
Tyre bead seater & Heavy duty pry bars	Page 114
Death blow hammer & magnetic holders	Page 115
Induction heater	Page 116 - 117
Hot stapler	Page 118
Auto body repair tools	Page 119
Mechanix display unit	Page 120 - 121

Tool cabinet

M3531 >

Tool Chest - 3 Drawers & Top
Fits M3760 & M3770

Top Chest 676 x 459 x 400
Drawer x3 568 x 398 x 75

- Locking drawers



M3500 - MDF02 >

Wooden Top Plate

Top Plate 676 x 459 x 30

- Apply for M3760 & M3770



M3760 >

Tool Cabinet - 6 Drawers
Handle for push or pull

Top Cabinet 676 x 459 x 815
Drawer x5 568 x 398 x 75
Drawer x1 568 x 398 x 154

- **Locking drawers**
- *You can only open 1 drawer at a time to avoid tilting of cabinet*



M3770 >

Tool Cabinet - 7 Drawers
Handle for push or pull

Top Cabinet 676 x 459 x 1005
Drawer x5 568 x 398 x 75
Drawer x2 568 x 398 x 154

- **Locking drawers**
- *You can only open 1 drawer at a time to avoid tilting of cabinet*



Tool cabinet & Tool trolley

M3591 >

Tool Cabinet - 6 Drawers & 1 Locker

1 Locker with 2 drawers. (Adjustable in height)

Handle for push or pull

Tool Cabinet 1044 x 459 x 1035

Drawer x1 938 x 398 x 135

Drawer x5 568 x 398 x 75

Drawer x1 568 x 398 x 154

Locker x1 330 x 398 x 588

Drawer x2 300 x 390 x 75

- Locking drawers



< M3593

Tool Trolley - 3 Drawers

Handle for push or pull

Tool Trolley 860 x 440 x 1000

Drawer x3 568 x 398 x 75

- Locking drawers

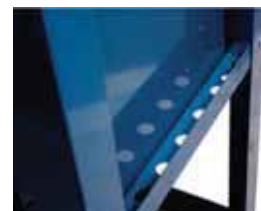



< M3397

Tool Trolley - 3 Trays
Handle for push or pull

Tool Trolley 910 x 459 x 985
Load per shelf max. 35 Kg

M3379 >

Tool Chest - 9 Drawers & Top
With Ball bearing slides

Tool Chest 660 x 307 x 433
Drawer x6 170 x 270 x 50
Drawer x2 570 x 270 x 50
Drawer x1 570 x 270 x 75

- Locking drawers



M3350 >

Metal Tool Box

Tool Box 475 x 200 x 200mm



Modules

tool modules - MD02 & MD12

M0023 >

Drawer 1



M0127 >

Drawer 2

M0032
32 Pc bit set
See page 108



Drawer 1

M0048 >

48 Pc 1/4" drive
socket set



M0027 >

27 Pc 1/2" drive
socket set



M0029 >

29 Pc 3/8" drive
socket set



Drawer 2

M0012 >

12 Pc gear
wrench set



M0013 >

13 Pc
wrench set



M0078 >

78 Pc bit set

M0032
32 pc bit set

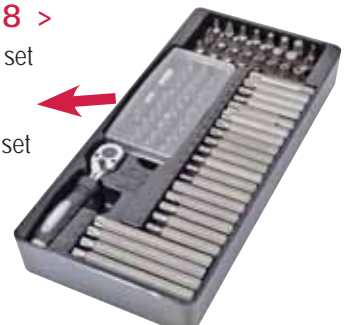

Drawer 3

M8304 >

4 Pc Deluxe
pliers set



M8306 >

6 Pc Torx
screwdriver set



M8308 >

8 Pc
screwdriver set



Drawer 4

M8011 >

11 Pc hammer &
punch set



M8107 >

7 Pc T5 handle
Tamper star wrench
& star key
wrench set



M8207 >

7 Pc T5 handle ball
point & star key
wrench set



Modules

tool modules - MD15

Drawer 1

M0048 >
48 Pc 1/4" drive
socket set



M0027 >
27 Pc 1/2" drive
socket set



M0029 >
29 Pc 3/8" drive
socket set



Drawer 2

M0012 >
12 Pc gear
wrench set



M0013 >
13 Pc
wrench set



M0078 >
78 Pc bit set

M0032
32 pc bit set

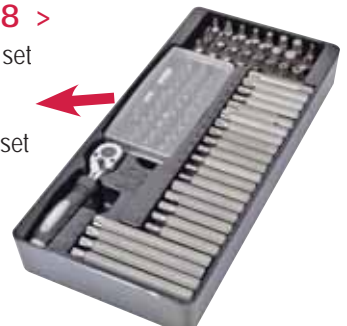

Drawer 3

M8304 >
4 Pc Deluxe
pliers set



M8306 >
6 Pc Torx
screwdriver set



M8308 >
8 Pc
screwdriver set



Drawer 4

M8011 >
11 Pc hammer &
punch set



M8107 >
7 Pc T5 handle
Tamper star wrench
& star key
wrench set



M8207 >
7 Pc T5 handle ball
point & star key
wrench set



Drawer 5

M0006 >
6 Pc double
flexible socket
wrench set



M8204 >
4 Pc
pliers set



M8104 >
4 Pc combination
wrench set



Modules

M0127 >

Handtools - 127 Pc - 1/2"Dr. & 1/4"Dr. Sockets - Bits

M0127: 560mm(L) x 390mm(W) x 60mm(H)

Content - 1/2"Dr. :

- Ratchet Handle (Quick release / 72 Teeth)
- Swivel Handle - 390mm
- Universal Joint
- Extension Bar - 5"/125mm
- Extension Bar - 10"/250mm
- Socket (6pt / mm) : 10 - 11 - 12 - 13 - 14 - 15 - 16 - 17 - 18 - 19 - 20 - 21 - 22 - 24 - 27 - 30 - 32 - 34
- E-Socket (6pt) : E12 - E14 - E16 - E18 - E20 - E22 - E24
- Deep Socket (6pt / mm) : 14 - 15 - 17 - 18 - 19 - 22 - 24
- Spark Plug Socket (6pt / mm) : 16 - 21
- Shank Bit Adaptor - 5/16"

Content - 1/4"Dr. :

- Ratchet Handle (Quick release / 72 Teeth)
- Universal Joint
- Spinner Handle - 150mm
- Bit Hex + Electric Wrench Adaptor
- Bit Adaptor - 1/4"
- Flex Bar - 150mm
- Extension Bar - 2"/50mm
- Extension Bar - 4"/100mm
- Socket (6pt / mm) : 4 - 4.5 - 5 - 5.5 - 6 - 7 - 8 - 9 - 10 - 11 - 12 - 13
- E-Socket (6pt) : E4 - E5 - E6 - E7 - E8 - E10 - E11
- Deep Socket (6pt / mm) : 6 - 7 - 8 - 9 - 10 - 11 - 12 - 13

Content - Others :

- 3-Way Adaptor : 3/8"F x 1/4"M - 3/8"F x 1/2"M
- Hex Key Set (mm) : 1.5 - 2 - 2.5

Shank Bits - 5/16"

- | | |
|-----------------------|--|
| Hex : H10 - H12 - H14 | Spline : M5 - M6 - M8 - M10 - M12 |
| Phillips : PH4 | Slotted (mm) : 8 - 10 - 12 |
| Pozi : PZ4 | Torx Tamperproof : TT45 - TT50 - TT55 - TT60 |



< **M0032**
Bit Set - 32 Pc
See Page 108
for contents



< M0023

Handtools - 23 Pc
Screwdriver, Pliers & Wrench

M0023: 560mm(L) x 390mm(W) x 40mm(H)

Content:

- Combination Wrench (mm) : 8 - 9 - 10 - 11 - 12 - 13 - 14 - 15 - 16 - 17 - 19
- Water Pliers - 250mm
- Long Nose Pliers - 200mm
- Combination Pliers - 180mm
- Diagonal Cutter - 160mm

Screwdrivers :

- Slotted (mm) : 5x75, 6x100, 6x150, 8x200
- Phillips : PH1x75, PH2x100
- Stubby - 38mm : SL6 - PH2

M0048 >

1/4"Dr. Socket set - 48 Pc

M0048: 390mm(L) x 190mm(W) x 60mm(H)

Content:

Ratchet Handle (Quick release / 72 Teeth)
 Universal Joint
 3-Way Adaptor : 3/8"F - 1/4"M
 Bit Hex + Electric Wrench Adaptor - 1/4"
 Spinner Handle - 150mm
 Extension Bar - 2"/50mm
 Extension Bar - 6"/150mm
 Socket (6pt / mm) : 4 - 4.5 - 5 - 5.5 - 6 - 7 - 8 - 9 - 10 - 11 - 12 - 13
 Deep Socket (6pt / mm) : 6 - 7 - 8 - 9 - 10 - 11 - 12 - 13

Bit Sockets :

Slotted (mm) : 4 - 5.5 - 6.5
 Philips : PH1 - PH2 - PH3
 Pozi : PZ1 - PZ2 - PZ3
 Torx Tamperproof : TT10 - TT15 - TT20 - TT25 - TT27 - TT30 - TT40
 Hex : H3 - H4 - H5 - H6 - H8



M0027 >

1/2"Dr. Socket set - 27 Pc

M0027: 390mm(L) x 190mm(W) x 60mm(H)

Content:

Ratchet Handle (Quick release / 72 Teeth)
 Universal Joint
 3-Way Adaptor : 3/8"F - 1/2"M
 Extension Bar - 5"/125mm
 Extension Bar - 10"/250mm
 Socket (6pt / mm) : 10 - 11 - 12 - 13 - 14 - 15 - 16 - 17 - 18 -
 19 - 20 - 21 - 22 - 24 - 27 - 30 - 32
 Deep Socket (6pt / mm) : 14 - 15 - 17 - 19 - 22



M0029 >

3/8"Dr. Socket set - 29 Pc

M0029: 390mm(L) x 190mm(W) x 60mm(H)

Content:

Ratchet Handle (Quick release / 72 Teeth)
 Universal Joint
 3-Way Adaptor : 1/2"F - 3/8"M
 Extension Bar - 3"/75mm
 Extension Bar - 6"/150mm
 Socket (6pt / mm) : 6 - 7 - 8 - 9 - 10 - 11 - 12 - 13 - 14 -
 15 - 16 - 17 - 18 - 19 - 20 - 21 - 22
 Deep Socket (6pt / mm) : 10 - 12 - 13 - 15 - 17
 Spark Plug Socket (6pt / mm) : 16 - 21



Modules

M0012 >

Gear Wrench set - 12 Pc

M0012: 390mm(L) x 190mm(W) x 60mm(H)

Content:

Gear Wrench (mm) : 8 - 10 - 12 - 13 - 14 - 15 - 17 - 19

Adaptors

1/4" Dr. (Quick release) : 10 mm

1/2" Dr. (Quick release) : 13 mm

3/8" Dr. (Quick release) : 19 mm

1/4" Dr. Bit (Mirror polish) : 10 mm



< M2012

Reversible Gear Wrench set - 12 Pc

M2012: 390mm(L) x 190mm(W) x 60mm(H)

Content:

Gear Wrench (mm) : 8 - 10 - 12 - 13 - 14 - 15 - 17 - 19

Adaptors

1/4" Dr. (Quick release) : 10 mm

1/2" Dr. (Quick release) : 13 mm

3/8" Dr. (Quick release) : 19 mm

1/4" Dr. Bit (Mirror polish) : 10 mm



M0013 >

Combination Wrench set - 13 Pc

M0013: 390mm(L) x 190mm(W) x 60mm(H)

Content:

Combination Wrench (mm) : 8 - 9 - 10 - 11 - 12 - 13 - 14 -
15 - 16 - 17 - 18 - 19 - 22



< M8104

Combination Wrench set - 4 Pc

M8104: 390mm(L) x 190mm(W) x 60mm(H)

Content:

Combination Wrench (mm) : 24 - 27 - 30 - 32



< M8203

Offset Ring Wrench set - 3 Pc

M8203: 390mm(L) x 190mm(W) x 60mm(H)

Content:

Offset Ring Wrench (mm) : 24/26 - 25/28 - 30/32

M0006 >

Double Flexible Socket Wrench set - 6 Pc

M0006: 390mm(L) x 190mm(W) x 60mm(H)

Content:

Double Flexible Socket Wrench (mm) : 8/9 - 10/11 - 12/13 - 14/15 -
16/17 - 18/19



< M8204

Pliers set - 4 Pc

M8204: 390mm(L) x 190mm(W) x 60mm(H)

Content:

External Straight - 180 mm

External Bent - 180 mm

Internal Straight - 180 mm

Internal Bent - 180 mm

M8304 >

Deluxe Pliers set - 4 Pc

M8304: 390mm(L) x 190mm(W) x 60mm(H)

Content:

Water Pliers - 250mm

Long Nose Pliers - 200mm

Combination Pliers - 180mm

Diagonal Pliers - 160mm



Modules



< M8306

Trox Screwdriver set - 6 Pc

M8306: 390mm(L) x 190mm(W) x 60mm(H)

Content:

Torx Screwdriver

- 100mm: T10 - T15 - T20 - T25 - T30

- 115mm: T40

M8308 >

Screwdriver set - 8 Pc

M8308: 390mm(L) x 190mm(W) x 60mm(H)

Content:

Slotted (mm) : 5 x75

Slotted with Hex (mm) : 6 x100 - 6 x150 - 8 x200

Phillips: PH1 x75

Phillips with Hex : PH2 x100

Stubby - 38mm : SL6 - PH2



< M8107

T5 Handle Torx Tamperproof Wrench
& Torx Key Wrench set - 7 Pc

M8107: 390mm(L) x 190mm(W) x 60mm(H)

Content:

T5 Handle Torx Tamperproof Wrench
& Torx Key Wrench

- 100mm: T10 - T15

- 150mm: T20 - T25 - T27 - T30 - T40



M8207 >

T5 Handle Ball Point & Hex Key Wrench set - 7 Pc

M8207: 390mm(L) x 190mm(W) x 60mm(H)

Content:

T5 Handle Ball Point & Hex Key Wrench

- 100mm: H2 - H2.5 - H3

- 150mm: H4 - H5 - H6

- 200mm: H8



M0078 >

5/16" Bit set - 78 Pc

M0078: 390mm(L) x 190mm(W) x 60mm(H)

Content:

Stubby Ratchet Bit Handle

Phillips - 30mm : PH2 - PH3

Slotted - 30mm (mm) : 8 - 10

Torx Tamperproof - 30mm : TT20 - TT25 - TT27 - TT30 - TT40 - TT45 - TT50 - TT55 - TT60

Torx Tamperproof - 75mm : TT20 - TT25 - TT27 - TT30 - TT40 - TT45 - TT50 - TT55 - TT60

Torx Tamperproof - 120mm : T40 - T45 - T50 - T55

Spline - 30mm : M5 - M6 - M8 - M10 - M12

Spline - 75mm : M5 - M6 - M8 - M10 - M12

Hex - 30mm : H5 - H6 - H7 - H8 - H10 - H12

Hex - 75mm : H5 - H6 - H7 - H8 - H10



M0032: Bit set

32 Pc Bit set. See page 108 for contents.



< M0017

1/2"Dr. Impact Socket set - 17 Pc

M0017: 390mm(L) x 190mm(W) x 60mm(H)

Content:

Impact Socket

- 38mm (mm) : 10 - 11 - 12 - 13 - 14 - 15 -
16 - 17 - 19 - 21 - 22

- 42mm (mm) : 24

- 82mm (mm) : 17 - 19 - 21 - 22 - 24

M8011 >

Hammer & Punch set - 11 Pc

M8011: 390mm(L) x 190mm(W) x 60mm(H)

Content:

Punch (mm) : 2x115, 3x125, 4x150, 5x165, 6x180, 8x180

Center Punch (mm) : 2x120

Cold Chisel (mm) : 18x128

Soft Face Hammer (PU) : 460gr/35mm

Enginers Hammer : 300gr



< M8000

Storage module

M8000: 390mm(L) x 190mm(W) x 60mm(H)

Socket set

M1443 >

1/4" Dr. Socket set - 43 Pc

M1443: 290mm(L) x 210mm(W) x 60mm(H)

Content:

Ratchet Handle (Quick release / 72 Teeth)

Universal Joint

Spinner Handle - 150mm

Extension Bar - 2"/50mm

Extension Bar - 6"/150mm

Socket (6pt / mm) : 4 - 4.5 - 5 - 5.5 - 6 - 7 - 8 - 9 - 10 - 11 - 12 - 13

Deep Socket (6pt / mm) : 6 - 7 - 8 - 9 - 10 - 11 - 12 - 13

Bit Adaptor - 1/4"

Shank Bits :

Phillips : PH1 - PH2

Pozi : PZ1 - PZ2

Slotted (mm) : 4 - 5.5

Torx Tamperproof : TT10 - TT15 - TT20 - TT25 - TT27 - TT30

Hex : H3 - H4 - H5 - H6

Material : Socket = CR-V / Bit = S2

Packing Specification : N.W.=7.5 kgs / G.W.=8 kgs / Carton=5 pcs / CBM=0.024



M3852 >

3/8" Dr. Socket set - 52 Pc

M3852: 380mm(L) x 280mm(W) x 80mm(H)

Content:

Ratchet Handle (Quick release / 72 Teeth)

Universal Joint

Extension Bar - 3"/75mm

Extension Bar - 6"/150mm

Socket (6pt / mm) : 6 - 7 - 8 - 9 - 10 - 11 - 12 - 13 - 14 - 15 - 16 - 17 - 18 - 19 - 20 - 21 - 22

Deep Socket (6pt / mm) : 10 - 12 - 13 - 15 - 17

Spark Plug Socket (6pt / mm) : 16 - 21

3-Way Adaptor - 1/2"F

Bit Sockets :

Phillips : PH1 - PH2 - PH3

Pozi : PZ1 - PZ2

Slotted (mm) : 5.5 - 6.5

Torx Tamperproof : TT10 - TT15 - TT20 - TT25 - TT30 - TT40 - TT45 - TT50 - TT55

Hex : H3 - H4 - H5 - H6 - H7 - H8 - H10

Material : Socket = CR-V / Bit = S2

Packing Specification : N.W.=15.5 kgs / G.W.=16.5 kgs / Carton=4 pcs / CBM=0.045



Socket set

M1395 >

1/4" & 3/8" Dr. Socket set - 95 Pcs

M1395: 380mm(L) x 260mm(W) x 70mm(H)

Content - 1/4"Dr. :

Ratchet Handle (Quick release / 72 Teeth)

Universal Joint

3-Way Adaptor - 3/8"F

Bit Adaptor - 1/4"

Spinner Handle - 150mm

Extension Bar - 2"/50mm

Extension Bar - 6"/150mm

Socket (6pt / mm) : 4 - 4.5 - 5 - 5.5 - 6 - 7 - 8 - 9 - 10 - 11 - 12 - 13

Deep Socket (6pt / mm) : 6 - 7 - 8 - 9 - 10 - 11 - 12 - 13

Bits :

Phillips : PH1 - PH2

Pozi : PZ1 - PZ2

Slotted (mm) : 4 - 5.5

Torx Tamperproof : TT10 - TT15 - TT20 - TT25 - TT27 - TT30

Hex : H3 - H4 - H5 - H6

Material : Socket = CR-V / Bit = S2

Packing Specification : N.W.=14.2 kgs / G.W.=13.7 kgs / Carton=3 pcs / CBM=0.030

Content - 3/8"Dr. :

Ratchet Handle (Quick release / 72 Teeth)

Universal Joint

3-Way Adaptor - 1/2"F

Extension Bar - 3"/75mm

Extension Bar - 6"/150mm

Socket (6pt / mm) : 6 - 7 - 8 - 9 - 10 - 11 - 12 - 13 - 14 - 15 - 16 - 17 - 18 - 19 - 20 - 21 - 22

Deep Socket (6pt / mm) : 10 - 12 - 13 - 15 - 17

Spark Plug Socket (6pt / mm) : 16 - 21

Bit Sockets :

Phillips : PH1 - PH2 - PH3

Pozi : PZ1 - PZ2

Slotted (mm) : 5.5 - 6.5

Torx Tamperproof : TT10 - TT15 - TT20 - TT25 - TT30 - TT40 - TT45 - TT50 - TT55

Hex : H3 - H4 - H5 - H6 - H7 - H8 - H10



M1297 >

1/4" & 1/2" Dr. Socket set - 97 Pc

M1297: 380mm(L) x 280mm(W) x 80mm(H)

Content 1/4"Dr.:

Ratchet Handle (Quick release / 72 Teeth)
 Universal Joint
 3-Way Adaptor - 3/8"F
 Spinner Handle - 150mm
 Extension Bar - 2"/50mm
 Extension Bar - 6"/150mm
 Socket (6pt / mm) : 4 - 4.5 - 5 - 5.5 - 6 - 7 - 8 - 9 - 10 - 11 - 12 - 13
 Deep Socket (6pt / mm) : 6 - 7 - 8 - 9 - 10 - 11 - 12 - 13
 E-Socket (6pt / mm) : E6 - E7 - E8 - E10 - E11

Bit Sockets :

Phillips : PH1 - PH2
 Pozi : PZ1 - PZ2
 Slotted (mm) : 4 - 5.5 - 6.5
 Torx Tamperproof : TT10 - TT15 - TT20 - TT25 - TT27 - TT30 - TT40
 Hex : H3 - H4 - H5 - H6 - H8

Material : Socket = CR-V / Bit = S2

Packing Specification : N.W.=18.5 kgs / G.W.=19.5 kgs / Carton=3 pcs
 / CBM=0.031

Content - 1/2"Dr. :

Ratchet Handle (Quick release / 72 Teeth)
 Universal Joint
 3-Way Adaptor - 3/8"F
 Shank Bit Adaptor - 5/16"
 Extension Bar - 5"/125mm
 Extension Bar - 10"/250mm
 Socket (6pt / mm) : 10 - 11 - 12 - 13 - 14 - 15 - 16 - 17 - 18 -
 19 - 20 - 21 - 22 - 24 - 27 - 30 - 32
 Deep Socket (6pt / mm) : 14 - 15 - 17 - 19
 E-Socket (6pt / mm) : E12 - E14 - E16 - E18 - E20
 Spark Plug Socket (6pt / mm) : 16 - 21

Content - others : Shank Bits - 5/16"

Phillips : PH3 - PH4
 Pozi : PZ3 - PZ4
 Slotted (mm) : 8 - 10 - 12
 Torx Tamperproof : TT40 - TT50 - TT55
 Hex : H10 - H12 - H14



Socket sets

M1228 >

1/2" Dr. Socket set - 28 Pc

M1228: 380mm(L) x 280mm(W) x 90mm(H)

Content:

Ratchet Handle (Quick release / 72 Teeth)

Universal Joint

3-Way Adaptor - 3/8"F

Extension Bar - 5"/125mm

Extension Bar - 10"/250mm

Socket (6pt / mm) : 10 - 11 - 12 - 13 - 14 - 15 - 16 - 17 - 18 -
19 - 20 - 21 - 22 - 24 - 27 - 30 - 32

Deep Socket (6pt / mm) : 14 - 15 - 17 - 19

Spark Plug Socket (6pt / mm) : 16 - 21

Material : Socket = CR-V

Packing Specification : N.W.=18.5 kgs / G.W.=19.5 kgs
Carton=4 pcs / CBM=0.043



< M3414

3/4" Dr. Socket set - 14 Pc

M3414: 500mm(L) x 390mm(W) x 100mm(H)

Content:

Ratchet Handle (Quick release / 72 Teeth / Solid / 500mm)

Extension Bar - 4"/100mm

Extension Bar - 8"/200mm

Sliding T-Bar - 450mm

Socket (6pt / mm) : 22 - 24 - 27 - 30 - 32 -
36 - 38 - 41 - 46 - 50

Material : CR-V

Packing Specification : N.W.=11 kgs / G.W.=12 kgs
Carton=1 pcs / CBM=0.026



M5713 >

3/4" Dr. Socket set - 21 Pc

M5713: 536mm(L) x 345mm(W) x 98mm(H)

Content:

Ratchet Handle (40 Teeth)

Extension Bar - 4"/100mm

Extension Bar - 8"/200mm

Extension Bar - 16"/400mm

Sliding T-Bar - 450mm

Socket (6pt / mm) : 19 - 21 - 22 - 23 - 24 - 26 - 27 - 29 -
30 - 32 - 35 - 36 - 38 - 41 - 46 - 50



Material : CR-V

Packing Specification : N.W.=14 kgs / G.W.=15 kgs Carton=1 pc / CBM=0.03

M8015 >

1" Dr. Socket Wrench set with Metal case - 15 Pc

M8015: 500mm(L) x 390mm(W) x 100mm(H)

Content:

Ratchet Hand

Reversible Handle - 635mm

Extension Bar - 8"/200mm

Extension Bar - 16"/400mm

Sliding T-Bar - 450mm

Socket (6pt / mm) : 36 - 41 - 46 - 50 - 55 - 60 - 65 - 70 - 75 - 80



Material : CR-V

Packing Specification : N.W.=28.6 kgs / G.W.=30 kgs / Carton=1 pc / CBM=0.03



Tool set

M0105 >

1/4" & 1/2" Dr. Socket set in Aluminium case - 105 Pc

M0105: 565mm(L) x 350mm(W) x 100mm(H)

Content - 1/4"Dr. :

Ratchet Handle (Quick release / 72 Teeth)
Universal Joint
Spinner Handle - 150mm
Extension Bar - 2"/50mm
Extension Bar - 4"/100mm
Socket (6pt / mm) : 4 - 4.5 - 5 - 5.5 - 6 - 7 - 8 - 9 - 10 - 11 - 12 - 13
Deep Socket (6pt / mm) : 8 - 10 - 13
E-Socket (6pt) : E6 - E7 - E8

Bit Sockets :

Phillips : PH1 - PH2
Pozi : PZ1 - PZ2
Spline : M4 - M5 - M6
Torx Tamperproof : TT10 - TT15 - TT20 - TT25 - TT27 - TT30 - TT40
Hex : H3 - H4 - H5 - H6

Content - Others :

Ball Key set (mm) : 1.5 - 2 - 2.5 - 3 - 4 - 5 - 6 - 8 - 10
Combination Wrench (mm) : 8 - 10 - 12 - 13 - 14 - 17 - 19

Bits - 30mm : 5/16"

Phillips : PH3
Pozi : PZ3
Spline : M8 - M10 - M12
Torx Tamperproof : TT45 - TT50 - TT55 - TT60
Hex : H8 - H10

Content - 1/2"Dr. :

Ratchet Handle (Quick release / 72 Teeth)
Universal Joint
Shank Bit Adaptor - 5/16"
3-Way Adaptor - 3/8"
Extension Bar - 4.5"/115mm
Extension Bar - 10"/250mm
Socket (6pt / mm) : 10 - 11 - 12 - 13 - 14 - 15 - 16 - 17 - 18 -
19 - 20 - 21 - 22 - 24 - 27 - 30 - 32 - 34
Deep Socket (6pt / mm) : 14 - 15 - 17 - 19 - 22
E-Socket (6pt) : E10 - E12 - E14 - E16 - E18 - E20
Spark Plug Socket (6pt / mm) : 16 - 21

Bit Sockets :

Phillips : PH1 - PH2
Pozi : PZ1 - PZ2
Spline : M4 - M5 - M6
Torx Tamperproof : TT10 - TT15 - TT20 - TT25 - TT27 - TT30 - TT40
Hex : H3 - H4 - H5 - H6

Material : Socket = CR-V / Bit = S2

Packing Specification : N.W.=19 kgs / G.W.=20 kgs /
Carton=2 pcs / CBM=0.04



M1500 >

1/2"Dr. & 1/4"Dr. Sockets - 127 Pc

M0127: 560mm(L) x 390mm(W) x 60mm(H)

Content - 1/2"Dr. :

- Ratchet Handle (Quick release / 72 Teeth)
- Swivel Handle - 390mm
- Universal Joint
- 3-Way Adaptor - 3/8"F
- Extension Bar - 5"/125mm
- Extension Bar - 10"/250mm
- Socket (6pt / mm) : 10 - 11 - 12 - 13 - 14 - 15 - 16 - 17 - 18 - 19 - 20 - 21 - 22 - 24 - 27 - 30 - 32 - 34
- E-Socket (6pt) : E12 - E14 - E16 - E18 - E20 - E22 - E24
- Deep Socket (6pt / mm) : 14 - 15 - 17 - 18 - 19 - 22 - 24
- Spark Plug Socket (6pt / mm) : 16 - 21
- Shank Bit Adaptor - 5/16"

Content - 1/4"Dr. :

- Ratchet Handle (Quick release / 72 Teeth)
- Universal Joint
- Spinner Handle - 150mm
- Bit Hex + Electric Wrench Adaptor - 1/4"
- Bit Adaptor - 1/4"
- 3-Way Adaptor - 3/8"F
- Flex Bar - 150mm
- Extension Bar - 2"/50mm
- Extension Bar - 4"/100mm
- Socket (6pt / mm) : 4 - 4.5 - 5 - 5.5 - 6 - 7 - 8 - 9 - 10 - 11 - 12 - 13
- E-Socket (6pt) : E4 - E5 - E6 - E7 - E8 - E10 - E11
- Deep Socket (6pt / mm) : 6 - 7 - 8 - 9 - 10 - 11 - 12 - 13

Content - Others :

- Hex Key Set (mm) : 1.5 - 2 - 2.5
- Combination Wrench (mm) : 8 - 9 - 10 - 11 - 12 - 13 - 14 - 15 - 16 - 17 - 19
- Water Pliers - 250mm
- Long Nose Pliers - 200mm
- Combination Pliers - 180mm
- Diagonal Cutter - 160mm

Shank Bits : 5/16"

- Hex : H10 - H12 - H14
- Phillips : PH4
- Pozi : PZ4
- Spline : M5 - M6 - M8 - M10 - M12
- Slotted (mm) : 8 - 10 - 12
- Torx Tamperproof : TT45 - TT50 - TT55 - TT60

Screwdrivers :

- 38mm : SL6 - PH2
- 75mm : SL5 - PH1
- 100mm : SL6 - PH2
- 150mm : SL6
- 200mm : SL8



M0032: Bit set
32 Pc Bit set. See page 108 for contents.



Tool set

M1256 >

1/2" Dr. Tool set - 56 Pc

M1256: 565mm(L) x 350mm(W) x 100mm(H)

Content - 1/2"Dr. :

Ratchet Handle (Quick release / 72 Teeth)

Universal Joint

Extension Bar - 5"/125mm

Socket (6pt / mm) : 10 - 11 - 12 - 13 - 15 - 17 - 19 - 22 - 24 - 27

Spark Plug Socket (6pt / mm) : 16 - 21

Content - others :

Hex Key Set (mm) : 1.5 - 2 - 3 - 4

Combination Wrench (mm) : 11 - 12 - 13 - 14 - 15 - 17

Water Pliers - 250mm

Combination Pliers - 180mm

Hammer - 300g

Screwdrivers :

- 40mm : SL6 - PH6

- 100mm : SL6 - PH6

- 200mm : PZ8

Material : Socket = CR-V / Bit = S2

Packing Specification : N.W.=19 kgs / G.W.=20 kgs /

Carton=2 pcs / CBM=0.04

Content - 1/4"Dr. :

Bit Adaptor - 1/4"/6mm

Spinner Handle - 150mm

Socket (6pt / mm) : 8 - 9 - 10 - 11 - 12 - 13

Bits :

Phillips : PH1 - PH2 - PH3

Slotted (mm) : 4 - 5.5 - 7

Torx Tamperproof : TT10 - TT15 - TT20 - TT30

Hex : H3 - H4 - H5 - H6



M0119 >

1/4" & 1/2" Dr. Tool set - 119 Pc

M0119:565mm(L) x 350mm(W) x 100mm(H)

Content - 1/2"Dr. :

Ratchet Handle (Quick release / 72 Teeth)
 Universal Joint
 Bit Adaptor - 5/16"
 Extension Bar - 3"/75mm
 Extension Bar - 10"/250mm
 Extension Bar (Flexible) - 15"/375mm
 Socket (6pt / mm) : 10 - 11 - 12 - 13 - 14 - 15 - 16 - 17 - 18
 19 - 20 - 21 - 22 - 23 - 24 - 27 - 30 - 32
 E-Socket (6pt) : E10 - E11 - E12 - E14 - E16 - E18 - E20 - E22
 Spark Plug Socket (6pt / mm) : 16 - 21

Bits - 30mm :

Slotted (mm) : 3 - 4 - 5.5 - 7
 Phillips : PH1 - PH2 - PH3
 Torx Tamperproof : TT10 - TT20 - TT25 - TT27 - TT30 -
 TT40 - TT45 - TT50

Bits - 75mm :

Hex : H4 - H5 - H6 - H7 - H8 - H10 - H12

Content - others :

Combination Wrench (mm) :
 6 - 7 - 8 - 9 - 10 - 12 - 13 - 14
 15 - 16 - 17 - 18 - 19 - 21 - 22
 24 - 27

Water Pliers - 250mm
 Combination Pliers - 180mm
 Hammer - 300g

Screwdrivers :

- 40mm : SL6 - PH6
 - 200mm : SL8 - PH8

Material : Socket = CR-V / Bit = S2

Packing Specification : N.W.=12.5 kgs / G.W.=11.5 kgs / Carton=1 pc / CBM=0.025

Content - 1/4"Dr. :

Ratchet Handle (Quick release / 72 Teeth)
 Spinner Handle - 150mm
 Universal Joint
 Bit Adaptor
 Extension Bar - 2"/50mm
 Extension Bar - 4"/100mm
 Extension Bar (Flexible) - 6"/150mm
 Sliding T-Bar - 110mm
 Socket (6pt / mm) : 4 - 5 - 6 - 7 - 8 - 9 - 10 - 11 - 12 - 13

Bits :

Slotted (mm) : 3 - 4 - 5.5 - 7
 Phillips : PH1 - PH2 - PH3
 Pozi : PZ1 - PZ2 - PZ3
 Torx Tamperproof : TT10 - TT15 - TT20 - TT30
 Hex : H3 - H4 - H5 - H6



Adaptor sets

M1209 >

Extension Bar set - 9 Pc

M1209: 280mm(L) x 182mm(W) x 50mm(H)

Content

Extension Bar

- 50mm / 2" : 1/4" - 1/2"
- 75mm / 3" : 3/8"
- 100mm / 4" : 1/4" - 3/8"
- 125mm / 5" : 1/2"
- 225mm / 9" : 1/4" - 3/8"
- 250mm / 10" : 1/2"

Material : CR-V

Packing Specification : N.W.=28 kgs / G.W.=29 kgs / Carton=20 pc / CBM=0.065



< M1234

Adaptor set - 6 Pc

M1234: 150mm(L) x 107mm(W) x 50mm(H)

Content

Adaptor

- 1/4"(M) : 3/8"(F)
- 3/8"(M) : 1/4"(F) - 1/2"(F)
- 1/2"(M) : 3/8"(F) - 3/4"(F)
- 3/4"(M) : 1/2"(F)

Material : CR-V

Packing Specification : N.W.=17 kgs / G.W.=18 kgs
Carton=36 pc / CBM=0.028



M1208 >

Dr. Adaptor & Universal Joint set - 8 Pc

Content :

Dr. Universal Joint : 1/4" - 3/8" - 1/2"

Dr. Adaptor :

- 1/4" (M) : 3/8" (F)
 - 3/8" (M) : 1/4" (F) - 1/2" (F)
 - 1/2" (M) : 3/8" (F)
- Bit Adaptor : 1/4"

Material : CR-V



Socket sets



< M0043

1/4", 3/8" & 1/2" Dr. Xi-on Socket set - 43 Pc

The Xi-on Socket Set offers an improved design on the point of contact and always succeeds in those approximately 85% rounded nuts/bolts compared to conventional sockets.

Features:

- Protects the nut/bolt, prevents the nut/bolt from rounding.
- High performance design allows the socket to contact the nut/bolt away from the corner while the torque can evenly spread all over the head of the nut/bolt makes the turning labor-saving.
- Extends the life of a nut/bolt

Content :

- 1/4"Dr. : 4, 4.5, 5, 5.5, 6, 7, 8, 9, 10, 11, 12, 13 mm
- 3/8"Dr. : 8, 10, 11, 12, 13, 14, 15, 16, 17, 18, 19, 20, 21, 22, 24 mm
- 1/2"Dr. : 8, 10, 11, 12, 13, 14, 15, 16, 17, 19, 21, 22, 24, 27, 30, 32 mm

< M0034

Star Bit Socket set - 34 Pc

Content :

E-Socket :

- 1/4" : E4 - E5 - E6 - E7 - E8
- 3/8" : E10 - E12 - E14 - E16
- 1/2" : E18 - E20

Bit Socket - Torx :

- 1/4" : T8 - T10 - T15 - T20 - T25 - T27 - T30
- 3/8" : T40 - T45 - T47 - T50
- 1/2" : T55 - T60

Bit Socket - Torx Tamperproof :

- 1/4" : TT10 - TT15 - TT20 - TT25 - TT27 - TT30
- 3/8" : TT40 - TT45 - TT50
- 1/2" : TT55

Material : CR-V



M2435 >

1/4" Reversible Bit & Socket Ratchet Handle set - 35 Pc

M2435: 173mm(L) x 105mm(W) x 42mm(H)

Content - 1/4"Dr:

- Ratchet Handle (Double reversible / 72 Teeth)
- Bit Adapter - 4"
- Extension Bar - 4"/100mm
- Socket (6pt / mm) : 4 - 4.5 - 5 - 5.5 - 6 - 7 - 8 - 9 - 10 - 11 - 12 - 13

Bits :

- Slotted (mm) : 4 - 5.5 - 6.5
- Phillips : PH1 - PH2 - PH3
- Pozi : PZ1 - PZ2 - PZ3
- Torx Tamperproof : TT10 - TT15 - TT20 - TT25 - TT27 - TT30
- Hex : H3 - H4 - H5 - H6 - H8

Material : CR-V, Matted Surface

Packing Specification : N.W.=7.36 kgs / G.W.=7.86 kgs /
Carton=4 pc / CBM=0.04



Ratchet handles

Ratchet handles >

M0142 : 1/4" Ratchet Handle - 72 Teeth
Length - 132mm



M0142

M0382 : 3/8" Ratchet Handle - 72 Teeth
Length - 270mm



M0382

M0122 : 1/2" Ratchet Handle - 72 Teeth
Length - 435mm



M0122



M0141 : 1/4" Ratchet Handle - 72 Teeth

M0121 : 1/2" Ratchet Handle - 72 Teeth

M0381 : 3/8" Ratchet Handle - 72 Teeth

M0003 >

Stubby Ratchet Handle set - 3 Pc

M0003 : mm(L) x mm(W) x mm(H)

Content :

Ratchet Handle - 72 Teeth (Stubby) :

- 95mm : 1/4"
- 115mm : 3/8"
- 150mm : 1/2"

Material : CR-V



Gear wrenches

M7580 - M7599 >

Gear wrenches

- M7580 : 8mm / 140mm(L) x 16.5mm(W) / Carton=10 pcs
- M7583 : 9mm / 143mm(L) x 19.0mm(W) / Carton=10 pcs
- M7584 : 10mm / 160mm(L) x 20.7mm(W) / Carton=10 pcs
- M7585 : 11mm / 168mm(L) x 22.4mm(W) / Carton=10 pcs
- M7586 : 12mm / 174mm(L) x 23.7mm(W) / Carton=10 pcs
- M7587 : 13mm / 180mm(L) x 25.7mm(W) / Carton=10 pcs
- M7588 : 14mm / 193mm(L) x 27.4mm(W) / Carton=10 pcs
- M7589 : 15mm / 200mm(L) x 28.8mm(W) / Carton=10 pcs
- M7591 : 16mm / 216mm(L) x 30.4mm(W) / Carton=10 pcs
- M7592 : 17mm / 233mm(L) x 32.3mm(W) / Carton=10 pcs
- M7593 : 18mm / 239mm(L) x 33.4mm(W) / Carton=10 pcs
- M7594 : 19mm / 250mm(L) x 34.5mm(W) / Carton=10 pcs
- M7596 : 21mm / 285mm(L) x 42.0mm(W) / Carton= 6 pcs
- M7597 : 22mm / 285mm(L) x 42.0mm(W) / Carton= 6 pcs
- M7598 : 24mm / 325mm(L) x 47.0mm(W) / Carton= 6 pcs
- M7599 : 25mm / 325mm(L) x 47.5mm(W) / Carton= 6 pcs

Material : CR-V



< M7808 - M7819

Reversible gear wrenches

- M7808 : 8mm / 135mm(L) x 17.0mm(W) / Carton=10 pcs
- M7809 : 9mm / 148mm(L) x 18.5mm(W) / Carton=10 pcs
- M7810 : 10mm / 158mm(L) x 20.0mm(W) / Carton=10 pcs
- M7811 : 11mm / 165mm(L) x 22.0mm(W) / Carton=10 pcs
- M7812 : 12mm / 172mm(L) x 23.0mm(W) / Carton=10 pcs
- M7813 : 13mm / 176mm(L) x 25.0mm(W) / Carton=10 pcs
- M7814 : 14mm / 191mm(L) x 27.0mm(W) / Carton=10 pcs
- M7815 : 15mm / 206mm(L) x 33.0mm(W) / Carton=10 pcs
- M7816 : 16mm / 208mm(L) x 30.0mm(W) / Carton=10 pcs
- M7817 : 17mm / 231mm(L) x 37.0mm(W) / Carton=10 pcs
- M7818 : 18mm / 234mm(L) x 37.0mm(W) / Carton=10 pcs
- M7819 : 19mm / 246mm(L) x 39.0mm(W) / Carton=10 pcs

Material : CR-V

M2402 >

Reversible multi gear wrench - 2 Pc

Specification :

Fits 5 different nut and bolt styles:

- 6pt Hex : 5/16", 3/8", 7/16", 1/2", 9/16", 5/8", 11/16", 3/4"
- 12pt Hex (mm) : 8, 10, 11, 13, 14, 16, 17, 19
- External Torx : E10, E12, E14, E18, E20, E24
- Spline : M10, M12, M14, M16, M18, M20, M22
- Square: 5/16", 3/8", 7/16", 1/2", 9/16"

Material : CR-V



Gear wrench sets

M2305 >

Gear Wrench set (72 Teeth) - 5 Pc

M2305: 280mm(L) x 190mm(W) x 50mm(H)

Content:

Gear Wrench (72 Teeth / mm) : 8 - 10 - 13 - 17 - 19

Material : CR-V

Packing Specification : N.W.=10.3 kgs / G.W.=11.8 kgs
Carton=10 pc / CBM=0.038



< M2308

8 Pc Gear Wrench Set, 72 teeth, CR-V 6140.

M2308: 275mmx200mmx50mm (LxWxH)

Content:

8 - 10 - 12 - 13 - 14 - 15 - 17 - 19 mm

Packing specification:

Carton: 10 / N.W.(Kgs): 13.6 / G.W.(Kgs): 15.1 / CBM: 0.038

M2312 >

12 Pc Gear Wrench Set, 72 teeth, CR-V 6140.

M2312: 295mmx290mmx60mm (LxWxH)

Content:

8 - 9 - 10 - 11 - 12 - 13 - 14 - 15 - 17 - 16 - 17 - 18 - 19 mm

Packing specification:

Carton: 10 / N.W.(Kgs): 21.9

G.W.(Kgs): 23.9 / CBM: 0.071



Reversible gear wrench sets



< M2405

Reversible Gear Wrench set (72 Teeth) - 5 Pc

M2405: 280mm(L) x 190mm(W) x 50mm(H)

Content:

Gear Wrench (Reversible / 72 Teeth / mm) : 8 - 10 - 13 - 17 - 19

Material : CR-V

Packing Specification : N.W.=10.3 kgs / G.W.=11.8 kgs
Carton=10 pc / CBM=0.039

M2408 >

Reversible Gear Wrench set (72 Teeth) - 8 Pc

M2408: 275mm(L) x 200mm(W) x 50mm(H)

Content:

Gear Wrench (Reversible / 72 Teeth / mm) :
8 - 10 - 12 - 13 - 14 - 15 - 17 - 19

Material : CR-V

Packing Specification : N.W.=15 kgs / G.W.=16.2 kgs
Carton=10 pc / CBM=0.037



< M2412

Reversible Gear Wrench set (72 Teeth) - 12 Pc

M2412: 295mm(L) x 290mm(W) x 60mm(H)

Content:

Gear Wrench (Reversible / 72 Teeth / mm) :
8 - 9 - 10 - 11 - 12 - 13 - 14 - 15 - 16 - 17 - 18 - 19

Material : CR-V

Packing Specification : N.W.=21.9 kgs / G.W.=23.9 kgs
Carton=10 pc / CBM=0.071



Combination wrenches



< M2339

Combination Wrench set - 13 Pc

Content :

Combination Wrench (mm) :
8 - 9 - 10 - 11 - 12 - 13 - 14 - 15 - 16 - 17
18 - 19 - 22

Material : CR-V

Packing Specification :

N.W.=22 kgs / G.W.=22.5 kgs
Carton=12 pc / CBM=0.05

M9104 >

Combination Wrench set - 4 Pc

Content :

Combination Wrench (mm) : 24 - 27 - 30 - 32

Material : CR-V

Packing Specification :

N.W.=7.36 kgs / G.W.=7.86 kgs
Carton=4 pc / CBM=0.04



Adjustable wrenches & Plier sets

M2560, M2562, M2563 >

Adjustable Wrenches

M2560 : 8" / 200mm

Material : CR-V

Packing Specification :

N.W.=24 kgs / G.W.= 29 kgs / Carton=80 / CBM=0.06

M2562 : 10" / 250mm

Material : CR-V

Packing Specification :

N.W.=19.8 kgs / G.W.= 23.4 kgs / Carton=50 / CBM=0.04

M2563 : 12" / 300mm

Material : CR-V

Packing Specification :

N.W.=24 kgs / G.W.= 29 kgs / Carton=80 / CBM=0.06



< M2502

Self adjusting multi-grip pliers - 2 Pc

Specification :

Innovative design allows the jaws to automatically adjust to any size
Straight and V-type jaws for hex, square and round objects

Set includes 175mm(L) & 255mm(L) pliers

Jaw capacity : 40mm & 60mm



M9416 >

Hose pinch off plier set - 3 Pc

Content :

(L) 8 inch - 203mm

(L) 10 inch - 254mm

(L) 12 inch - 304mm



Pliers set

M9304 >

Deluxe Pliers set - 4 pc

M9304: 390mm(L) x 190mm(W) x 60mm(H)

Content

Water Pliers - 250mm

Long Nose Pliers - 200mm

Combination Pliers - 180mm

Diagonal Pliers - 160mm

Material : CR-V

Packing Specification :

N.W.=25.5 kgs / G.W.= 26.5 kgs / Carton=20 / CBM=0.05



< M9438

Hose Clamp Pliers Jaw : 0-38 mm

Material : CR-MO

< M9455

Hose Clamp Pliers Jaw : 22-5 mm

Material : CR-MO

M9410 >

CV Boot Clamp Pliers

For easy installation of ear-type clamps on fuel filters water pumps, other cooling system hose and CV joint clamps.



< M9411

CV Boot Band Cutter - L=216mm

Special design to easily cut the stainless steel clamps without damaging the CV boot. Spring loaded action with heat treated 440 steel jaes and comfort grip handles.

Wire cutters



< M9402

Adjustable Wire Cutter / Stripper Tool

- Easily Cuts and strips wire 0.75 - 4.0 mm².
- Automatically adjusts to wire size.

Packing Specification :

N.W.=14.5 kgs / G.W.=15.5 kgs / Carton=60 / CBM=0.045

M9404 >

Multi-Purpose 4-in-1 Cutter

- Pliers in nose.
- Easily cuts and strips wire Ø0.8 ~ Ø0.26 mm.
- TPR handles for comfortable soft grip.

Packing Specification :

N.W.=8.5 kgs / G.W.=9.5 kgs / Carton=60 / CBM=0.039



< M9405

Oblique Cutter - 5"

- High quality diagonal cutter pliers designed for precision work, durable and sharp cutting edge by CNC grinding machine.
- This tool is the best choice for making the flush cut in any soft wire.
- It is also suitable for injection gate, electronic repair, craftwork or jewelry making ect.
- It offers user a TPR comfortable soft grip and return spring action.
- Use for plastic or under 2.0 mm soft material only.

Packing specification:

N.W.=6.3 kgs / G.W.=7.3 kgs / Carton=60 / CBM=0.028



M9406 >

Multi-Purpose 5-in-1 Cutter

- Crimps insulated terminals 1.5 - 2.5 - 6.0 mm².
- Crimps open barrel terminals & disconnectors 1.5 - 2.5 - 6.0 mm².
- Easily cuts and strips wire 0.75 - 1.0 - 1.5 - 2.5 - 4.0 - 6.0 mm².
- Cleanly shears bolts M2.6 - M3.0 - M3.5 - M4.0 - M5.0.
- TPR handles for comfortable soft grip.

Packing Specification :

N.W.=16.6 kgs / G.W.=17.6 kgs / Carton=48 / CBM=0.040



Screwdrivers



< M9305

Screwdriver set - 5 pc

M9305: 300mm(L) x 125mm(W) x 40mm(H)

Content :

Slotted (mm) : 3.5 x 75 - 5.5 x 125 - 6.5 x 150

Philips : PH1 x 80 - PH2 x 100

Material : CR-V

Packing Specification :

N.W.=10.6 kgs / G.W.= 11.6 kgs / Carton=24 /CBM=0.048

M9308 >

Screwdriver set - 8 Pc

M9308: 390mm(L) x 190mm(W) x 60mm(H)

Content :

Slotted (mm) : 5 x 75

Slotted with Hex (mm) : 6 x 100 - 6 x 150 - 8 x 200

Philips : PH1 x 75

Philips with Hex : PH2 x 100

Stubby - 38mm : SL6 - PH2

Material : CR-V

Packing Specification :

N.W.=18 kgs / G.W.= 20 kgs / Carton=20 / CBM=0.06

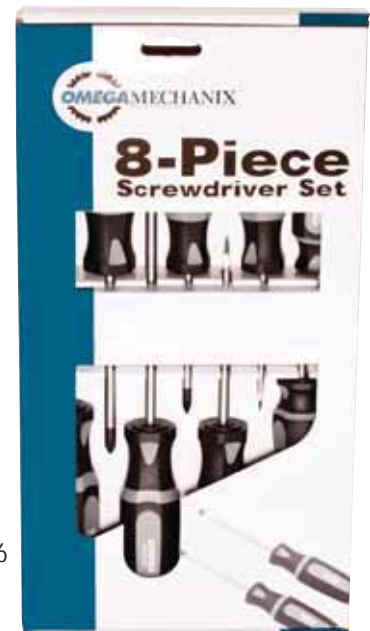

< M9306

Trox Screwdriver set - 6 Pc

M9306: 300mm(L) x 165mm(W) x 40mm(H)

Content :

Torx Screwdriver

- 100mm : T10 - T15 - T20 - T25 - T30

- 115mm : T40

Material : CR-V

Packing Specification :

N.W.=12.6 kgs / G.W.= 14.6 kgs / Carton=20 / CBM=0.05



Screwdrivers

M9307 >

Hexagon Screwdriver set - 7 Pc

M9307:

Content :

- 75 (mm) : 2.5, 3.0
- 100 (mm) : 4.0, 5.0
- 125 (mm) : 6.0
- 150 (mm) : 8.0, 10.0



< M9383

Stubby Screwdriver set - 3 Pc

M9383: 113mm(L) x 115mm(W) x 37mm(H)

Content :

- Philips : PH2 x 38
- Slotted (mm) : 6.5 x 38
- Pozi : PZ2 x 38

Material : CR-V

M9393 >

Long Screwdriver set - 3 Pc

M9393: 525mm(L) x 155mm(W) x 37mm(H)

Content :

- Philips : PH1 x 400
- Slotted (mm) : 4 x 400
- Pozi : PZ1 x 400

Material : CR-V



Torque wrenches

M030N, M110N, M210N, M500N >

M030N : Torque Wrench - 1/4" / 6 - 30Nm

M110N : Torque Wrench - 3/8" / 19 - 110Nm

M210N : Torque Wrench - 1/2" / 40 - 210Nm

M500N : Torque Wrench - 1/2" / 100 - 500Nm



M030N 1/4" Drive



M110N 3/8" Drive



M210N 1/2" Drive



M500N 3/4" Drive



< M2214, M2238, M2212

M2214 : Dual Way Torque Wrench - 1/4" Dr.
Range - 5 - 25 Nm

M2238 : Dual Way Torque Wrench - 3/8" Dr.
Range - 20 - 100 Nm

M2212 : Dual Way Torque Wrench - 1/2" Dr.
Range - 60 - 340 Nm



< M1000N

M1000N : Torque Wrench - 1" / 1000Nm



1240mm

Torque wrenches & Ratchet handles

M1500N >

M1500N : Torque Wrench - 1" / 1500Nm



1170mm

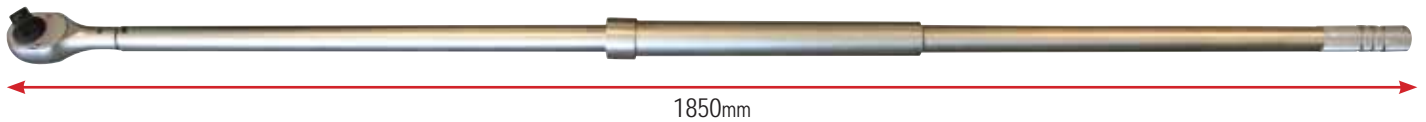

1850mm

M1219 >

Telescopic Ratchet Handle - 1/2" Dr.

M1219 : Max. Torque=750 Nm /
330-485mm (13"-19") / 48 Teeth



330 - 485mm



M7320 >

Breaker Bar - 1/2" Dr.

M7320 : Length 600mm

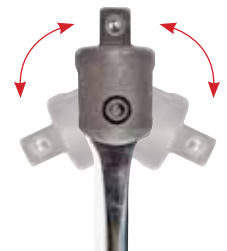

M3424 >

Extension Telescopic Ratchet Handle - 3/4" Dr.

M3424 : Max. Torque=1074 Nm / 610 - 915mm (24"-36") / 24 Teeth



Air impact wrenches



< M2063

Air Impact Wrench - 1/2" Dr.

Specification :

Square Drive	- 1/2"
No-Load Speed	- 8200rpm
Max Torque	- 1250 Nm / 922 ft-lb
3 Torque Forward	- Low : 245 Nm / 180 ft-lb
	- Medium : 650 Nm / 480 ft-lb
	- High : 990 Nm / 730 ft-lb
Air Consumption	- 245 L / min
Air Hose (I.D.)	- 8 mm
Air Inlet	- 1/4"
Weight	- 2.1 kg / 4.6 lb

M2060 >

Ultra Compact Air Impact Wrench - 3/8" Dr.
Twin Hammer , Handle Exhaust

Specification :

Square drive	- 3/8"
No-Load speed	- 11000 rpm
Max Torque	- 610 Nm / 450 ft-lb
Air pressure	- 90 PSI / 6.3 Bar
Air Consumption	- 200 L/min
Air Hose (I.D.)	- 10 mm
Air Inlet	- 1/4"
Bolt capacity	- 5/8" (16mm)



< M2064

Ultra Compact Air Impact Wrench - 1/2" Dr.
Twin Hammer , Handle Exhaust
Supplied with 1/2"(f) & 3/4"(m) adaptor

Specification :

Square drive	- 1/2"
No-Load speed	- 9000 rpm
Max Torque	- 1356 Nm / 1000 ft-lb
Air pressure	- 90 PSI / 6,3 Bar
Air Hose (I.D.)	- 10 mm
Air Inlet	- 1/4"
Bolt Capacity	- 7/8" (23mm)



Air impact wrenches

M2062 >

Air Impact Wrench - 1/2" Dr.

- Twin Hammer
- Light Weight, Aluminium & Composite
- 3 Forward Speed & 2 Reverse Speed
- Maximum Torque 1356 Nm

Specification :

Square Drive	- 1/2"
No-Load Speed	- 10000rpm
Max Torque	- 1356 Nm / 1000 ft-lb
Torque Forward	- 950 Nm / 700 ft-lb
Torque Reverse	- 1020 Nm / 752 ft-lb
Air Pressure	- 90 PSI / 6.3 Bar
Air Consumption	- 153 L / min
Air Hose (I.D.)	- 10 mm
Air Inlet	- 1/4"
Capacity	- 5/8" (16mm)



< M2072

Air Impact Wrench set - 15 pc

Content :

- M2062
- Impact Deep Socket with Plastic Sleeve (mm) : 17 - 19 - 21
- Impact Deep Socket (mm) : 22 - 23 - 24
- Oil Pot
- Hex Key - 4mm
- Nipple
- Mini Oiler

Air impact wrenches

M2034 >

Air Impact Wrench - 3/4" Dr.

- Twin Hammer
- Light Weight, High Torque
- 3 Forward Speed & 3 Reverse Speed
- Maximum Torque 1630 Nm

Specification :

Square Drive	- 3/4"
No-Load Speed	- 5500 rpm
Max Torque	- 1630 Nm / 1202 ft-lb
Torque Forward	- 1290 Nm / 951 ft-lb
Torque Reverse	- 1356 Nm / 1000 ft-lb
Air pressure	- 90 PSI / 6.3 Bar
Air Consumption	- 195L / min
Air Hose (I.D.)	- 13 mm
Air Inlet	- 3/8"
Bolt Capacity	- 1 1/8" (28mm)



M2016 >

Air Impact Wrench - 1" Dr.

Pinless Mechanism

- Powerfull Torque Output

Adjustable Torque

- 3 Forward Torque Setting

- 3 Reverse Torque Setting

Comfortable, Ergonomic Design

- Ergonomically Designed for the operator's comfort

- Long Typyr with 6" (15cm) Anvil

Specifications

Square Drive	- 1"
No-Load Speed	- 5000 Rpm
Max Torque	- 2712 Nm / 2000 ft-lb
Torque Forward	- 1742 Nm / 1285 ft-lb
Torque Reverse	- 1827 Nm / 1348 ft-lb
Air pressure	- 90 PSI / 6.3 Bar
Air Consumption	- 255 L/min
Air Hose (I.D.)	- 19 mm
Air Inlet	- 1/2"
Bolt Capacity	-

Cordless Impact wrenches

M2033 >

Cordless Impact Wrench - 1/2" Dr.
- Comes with 2 batteries

Specification :

Square Drive	- 1/2"
No-Load Speed	- 1800 rpm
Max Torque	- 588 Nm / 430 ft-lb
Impact per min.	- 2300
Voltage	- 18V DC
Charging time	- 1 hour Auto cut-off
Capacity	- 1/2" (13mm)
Weight	- 3 kg (incl. battery 0.53kg)



< M2038

Mini Cordless Impact Wrench - 3/8" Dr.
- Comes with 1 battery

Specification :

Square Drive	- 3/8"
No-Load Speed	- 2000 rpm
Max Torque	- 240 Nm / 177 ft-lb
Voltage	- 18V DC
Charging time	- 60 ~ 70 mins Auto cut-off
Capacity	- 3/8" (10mm)
Weight	- 2 kg (incl. battery 0.53kg)

M2041 >

Battery

Specifications :

18V DC
3.0 Ah Li-ion battery
Apply for : M2033, M2038



M2042 >

Battery Charger

Specifications :

18V
2.3 Ah Li-ion battery charger
Apply for : M2033, M2038



Impact sockets

M3322 >

1/2" Impact Socket set - 3 Pc

- Thin wall for sport/racing cars
- Plastic cover for protection against scratching
- Blow-mold case

M3322 : 148mm(L) x 132mm(W) x 450mm(H)

Content :

L = 85mm (mm) : 17 - 19 - 21

Material : CR-MO

Packing Specification :

N.W.=17 kgs / G.W.=17.5 kgs / Carton=36 pc / CBM=0.02



< M3314

1/2" Impact Socket set - 14 Pc

M3314 : 230mm(L) x 200mm(W) x 50mm(H)

Content :

L = 39mm (mm) : 10 - 12 - 13 - 14 - 17 - 19 - 22 - 24

L = 78mm (mm) : 17 - 19 - 21 - 22 - 24 - 27

Material : CR-MO

Packing Specification :

N.W.=10.8 kgs / G.W.=11.5 kgs / Carton=4 pc /

CBM=0.013

M3316 >

3/4" Impact Socket set - 16 Pc

M3316 : 470mm(L) x 345mm(W) x 84mm(H)

Content :

L = 90mm (mm) : 19 - 21 - 22 - 23 - 24 - 26 - 27

30 - 32 - 33 - 34 - 36 - 38 - 41

L = 95mm (mm) : 46 - 50

Material : CR-MO

Packing Specification :

N.W.=12 kgs / G.W.=13 kgs / Carton=1 pc / CBM=0.018



Impact adaptor set & wheel nut tools



< M3306

1/2" Dr. Impact Socket set - 6 Pc

M3306 : 110mm(L) x 300mm(W) x 50mm(H)

Content :

L = 88mm (mm) : MS17

L = 88mm (mm) : 15 - 17 - 19 - 21 - 22

Material : CR-V & CR-MO

M1217 >

1/2" Dr. Wheel Lug Socket - 1 Pc

Content :

L = 88mm (mm) : MS17

Material : CR-MO



< M3211

Impact socket adaptor set - 11 Pc

Content :

L = 39mm : 1/4" x 1/4" - 1.4" x 3/8"

3/8" x 1/4" - 3/8" x 3/8" - 3/8" x 1/2"

1/2" x 2/8" - 1/2" x 1/2" - 1/2" x 3/4"

3/4" x 1/2" - 3/4" x 1"

1" x 3/4"

Material : CR-MO



M3234 >

Impact Adaptor set - 6 Pc

M3234 : 150mm(L) x 107mm(W) x 50mm(H)

Content :

Adaptor

- 1/4"(M) : 3/8"(F)

- 3/8"(M) : 1/4"(F) - 1/2"(F)

- 1/2"(M) : 3/8"(F) - 3/4"(F)

- 3/4"(M) : 1/2"(F)

Material : CR-MO



Automotive clutch tools



< M9706

Clutch Aligner Tool for Trucks - 6 Pc

Content :

Mandrel NO. 1 (mm) : $\varnothing 36 - \varnothing 45$

Mandrel NO. 2 (mm) : $\varnothing 42 - \varnothing 52$

Centering Sleeve (mm) : $\varnothing 20, \varnothing 25, \varnothing 27, \varnothing 30$

M9711 >

Clutch Aligner set - 11 pc

Content :

Spigot Adaptor (mm) : $\varnothing 12 - \varnothing 14 - \varnothing 15 - \varnothing 16$
 $\varnothing 17 - \varnothing 18 - \varnothing 19 - \varnothing 20$

Mandrel (mm) : 15/19 - 20/26.6 - 23/36



< M9737

Self adjusting clutch (SAC) master tool kit - 38 pc

- Master tool kit for the professional disassembling & assembling of all self-adjusting clutches (SAC)
- Necessary for the pre-tightening of the SAC clutch pressure plates before their removal and installation
- Prevents plate distortion which may prevent the clutch from disengaging or cause dragging
- Single piece, six arm plate has been designed for SAC clutches with 6/8 locking holes

Content :

Clamping tool with 6 arms for clutches with 6/8 locking holes

Face spanner

Compression strut

Clutch mandrel set (BMW):

- 15mm x 23mm
- 15mm x 28mm
- 15mm x 34mm
- 15mm x 26.5mm
- 15mm x 32.5mm
- 15mm x 32.5mm (sleeve)

Clutch resetting tool

Handle for clamping tool

4 x knurled nuts for threaded bolts

Three lots of 4 x threaded bolt sets:

- M6 / 1.0 screw thread
- M8 / 1.25 screw thread
- M7 / 1.0 screw thread

Clutch centering tools:

- Centering handle
- Handle adapter
- Clamping cone (15-22mm)
- Clamping cone (22-28mm)
- Centering pin (12mm)
- Centering pin (14mm)
- Centering pin (15mm)
- Centering pin (16mm)
- Centering pin (17mm)
- Centering pin (18mm)
- Centering pin (19mm)



Automotive misc tools

M3206 >

Spring Compressor set

Specification :

Compression length 65 - 320 mm



< M3808

Strut Nut Kit - 8 Pc

M9711 : mm(L) x mm(W) x mm(H)

Content :

Internal Ø10.5 x 22mm Hex Dr. - 3.5mm PIN.
Internal Ø12.5 x 22mm Hex Dr. - 3.5mm PIN.
Internal Ø14.5 x 22mm Hex Dr. - 5mm PIN.
Internal Ø14 x 22mm Hex Dr. - 2.5mm PIN.
5mm x 60mm(L) x 1/2" Dr.
5.5mm x 48mm(L) x 1/2" Dr.
Internal Ø14.5 x 21mm Hex Dr. - 5mm PIN.
Internal Ø12.5 external Ø15.5 - 3mm PIN.



M9703 >

Tail Pipe Expander - 3 Pc

Content :

Small-Capacity : 1-1/8" to 1-3/4" (29-44mm) I.D
Medium-Capacity : 1-1/2" to 2-7/16" (38-62mm) I.D
Large-Capacity : 2-1/8" to 3-7/16" (54-87mm) I.D



< M3205

Mini Tube Bender set

Content :

One-Hand Bender
Dies : 3/16"(5mm) - 1/4"(6mm) - 5/16"(8mm)
3/8"(10mm) - 1/2"(12mm)



Automotive misc tools



< M3232

Cooling System & Radiator Cap Master Kit - 33 Pc

Content :

Universal Airvac Coolant Refiller

Extension Tube : $\varnothing 9.5\text{mm}$ x 600mm (L)

4 Conical Bushes: - 24-53 (Ford)

- 27-50.5

- $\varnothing 9.5\text{mm}$ Connector

- $\varnothing 9.5\text{mm}$ L-Type Connector

Content :

25 Adaptors



#01 (060)
Black
Mercedes



#08
Black
Adjustable Stationary Seat



#15 (041)
Black
Honda / Toyota



#22
Black
GM / Opel



#02
Blue
Audi (after 2000)



#09
Black
50mm Universal Connector
Used with #08 (Adjustable Stationary Seat)
Japanese and European Cars



#16 (043)
Black
Mitsubishi / Ford /
Nissan / Mazda



#23
Yellow (with Circlip)
BMW E-50



#03
Yellow
Opel / VW / Ford



#10
Black
35mm Universal Connector
Used with #08 (Adjustable Stationary Seat)
Japanese and European Cars



#17 (040)
Black
Ford



#24
Blue (with Circlip)
Ford Fiesta / Mondeo
(after 2010)
Mazda 3 (2005)



#04
Red (Maroon)
BMW



#11
Black
27mm Universal Connector
Used with #08 (Adjustable Stationary Seat)
for Japanese and European Cars



#18 (042)
Black
Ford



#25 (045)
Black
Toyota Previa / RAV 4



#05
Orange
BMW



#12
Black
Used to link #08 with
#09, #10 and #11



#19
Black
Mercedes



#06
Black
Audi / Citroen / Fiat / Peugeot



#13
Black
For cars with the cap
on the Radiator itself



#20
Black
Mercedes



#07
Black
Volvo / VW (before 2000)



#14
Steel Fastener
Used with adaptors and
seat accessories for
Toyota / Suzuki / Nissan



#21
Black
GM / Ford

Bearing driver & Oil filling system



< M3203

Universal Bearing Race and Seal Driver - 2 Pc



M3215 >

Transmission Oil Filling System - 15 Pc

Specification :

Capacity: 7.5 Liter

Part Number	Application
M3215-101	FORD 1/8-27 (NPT)
M3215-102	Universal BMW, Honda, Nissan, etc
M3215-103	VW/Audi, Skoda.
M3215-104	VW/Audi, Porsche.
M3215-105	VW/Audi, Mini Copper M10x1.0
M3215-106	VW/Audi DSG M24x1.5
M3215-107	VW/Audi CVT M22x1.5
M3215-108	Mercedes M12x1.5
M3215-109	V/W, Skoda M30x1.5
M3215-110	VW/Audi, Skoda M30x1.5
M3215-111	Universal Flexible 300mm, Honda, Hyundai, Kia, etc.
M3215-112	Volvo 5/16-24(UNF)
M3215-113	Toyota, Lexus M18x1.5
M3215-114	Nissan, Infinity M8x1.0
M3215-115	ATF-Adapter, V/W Passat.



Bit sets



< M0032

1/4" Bit set - 32 Pc

Content

Philips : PH1 - PH2 - PH3
 Slotted (mm) : 4 - 4.5 - 6.5
 Pozi : PZ1 - PZ2 - PZ3
 Torx : T8 - T10 - T15 - T20 - T25 - T27 - T30 - T40
 Torx Tamperproof : TT8 - TT10 - TT15 - TT20
 TT25 - TT27 - TT30 - TT40
 Hex : H3 - H4 - H5 - H6 - H8
 Bit Holder - 6mm : 1/4"Dr
 Bit Adapter - 60mm (Quick Magnetic) : 1/4"Dr.

M0138 >

1/2" Bit ratchet handle 72 teeth - 1 Pc



< M0060

Professional Bit set 3/8" Dr. & 1/2" Dr. - 60 Pc

M2008: mm(L) x mm(W) x mm(H)

Content :

Bit Adaptor : 3/8" Dr. - 10mm Hex
 1/2" Dr. - 10mm Hex
 14mm Hex
 Impact Adaptor : 10mm Hex (F) x 14mm Hex (M)

Material : SCM-V / CR-V / SNCM-V

Bit Lengths	30 mm		75 mm	
Bit Size	14 mm	10 mm		14 mm
Tx-Star		T60	T20-T25-T27-T30 T40-T45-T50-T55	T60
Spline		M12	M5-M6-M8-M10	M9-M12
Spline Temper.				M14
Hex.	H14-H17	H12	H4-H5-H6-H7-H8 H10	H9-H9.5 H12
Ribe			M6-M7-M8-M10	M12
Square			8mm-10mm	

Rethreading & Locking nut extractor set

M2020 >

Master Spindle Rethreading set - 20 Pc

This 20 pc set will repair or renew damaged threads on stub axles/spindles on most vehicles. The dies are made from high tempered steel for strenght and durability.

M2020 : mm(L) x mm(W) x mm(H)

Content :

Imperial sizes :

- 11/16" x 24
- 3/4" x 16
- 3/4" x 20
- 13/16" x 20
- 27/32" x 20
- 7/8" x 14
- 1" x 14

Metric sizes :

- 16 x 1.0
- 16 x 1.5
- 18 x 1.5
- 19 x 1.5
- 20 x 1.0
- 20 x 1.25
- 20 x 1.5
- 22 x 1.0
- 22 x 1.5
- 24 x 1.5
- 24 x 2.0
- 25 x 1.5
- 27 x 2.0



< M2008

Wheel Locking Nut Extractor set - 8 Pc

Content

Sockets

- Vertical Grooves / Hex=22mm : ø20 - ø22 - ø24 - ø27
- Horizontal Grooves / 1/2"Dr. : ø23 - ø25
- Drift - 150mm : To hammer the socket on the wheel nut.
- Punch - 135mm : To remove the wheel nut out of the socket.

M9414 >

Adjustable ball joint splitter for use on cars and commercial vehicle Jaw opening 20-30mm.



Pullers

2 Leg Adjustable Pullers >

Manual puller

- Adjustable in width

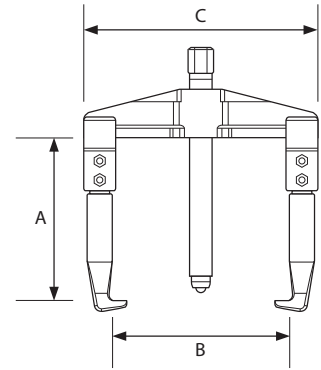

2 Leg Adjustable Puller

Model	AMP120310	AMP120315	AMP120720	AMP120725	AMP121230	AMP121235	AMP121240	AMP121550
Capacity	3 ton	3 ton	7 ton	7 ton	12 ton	12 ton	12 ton	15 ton
A (mm)	100	100	150	155	205	200	200	225
B (mm)	95	135	160	190	240	350	510	640
C (mm)	134	176	223	250	325	425	585	717
Weight(Kg)	1.1	1.3	3.5	3.6	7.5	9	15	23

2/3 Leg Pullers >

Manual puller

- Can be used with either 2 or 3 jaws
- The extra long jaws are adjustable in 4 positions
- The jaws have a special cut-out to pull

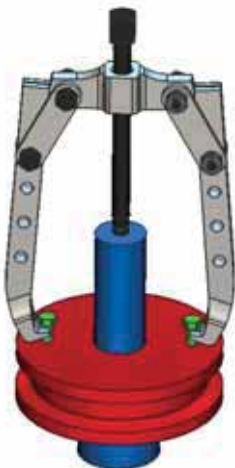

The jaws have a special cut-out to pull

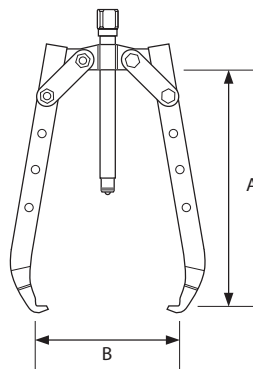

2/3 Leg Puller

Model	AMP230110	AMP230410	AMP230710	AMP230810
Capacity	1 ton	4 ton	7 ton	8 ton
A (mm)	120	210	270	270
B (mm)	125	220	280	330
Weight(Kg)	0.7	2.1	3.7	4.0

2/3 Leg Self-Centering Pullers >

Manual puller

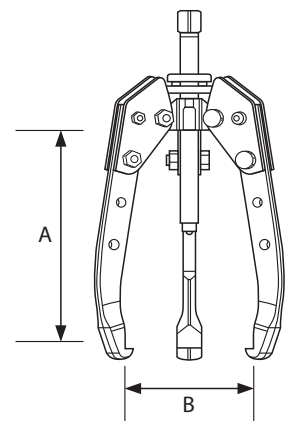

2/3 Leg Puller Self-Centering

Model	AMPC230110	AMPC230410	AMPC230710
Capacity	1 ton	4 ton	7 ton
A (mm)	120	210	270
B (mm)	125	220	280
Weight(Kg)	0.8	2.1	6.7

Pullers & Splitters

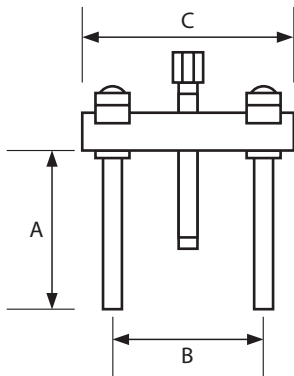

< Push Pullers

Manual puller

Model	Push Puller		
	AMP221102	AMPC221103	AMPC221110
A (mm)	120	120	190
B Max. (mm)	110	140	195
B Min. (mm)	46	46	63
C (mm)	122	156	210
Weight(Kg)	1	1.1	3.4

Splitters >

Manual puller

Model	Splitters		
	APS1202	APS1203	APS1204
A Max. (mm)	60	80	110
A Min. (mm)	4	6	10
B (mm)	60	80	110
R	3/8"	3/8"	5/8"
Weight(Kg)	0.7	1.3	2.7

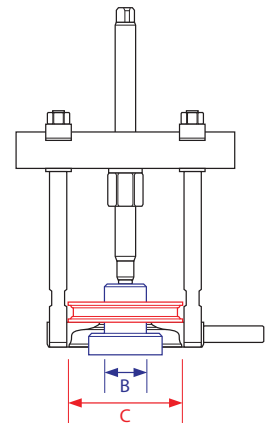
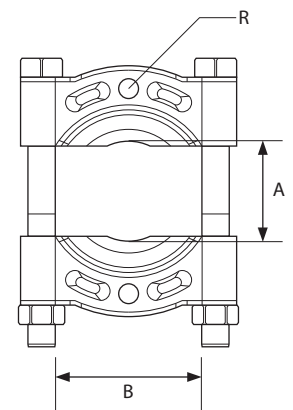

< Splitter Set

Manual puller

Model	Splitters Set		
	AMP320202	AMP320303	AMP321004
A (mm)	100	100	152
B (mm)	55	80	108
C (mm)	90	130	175

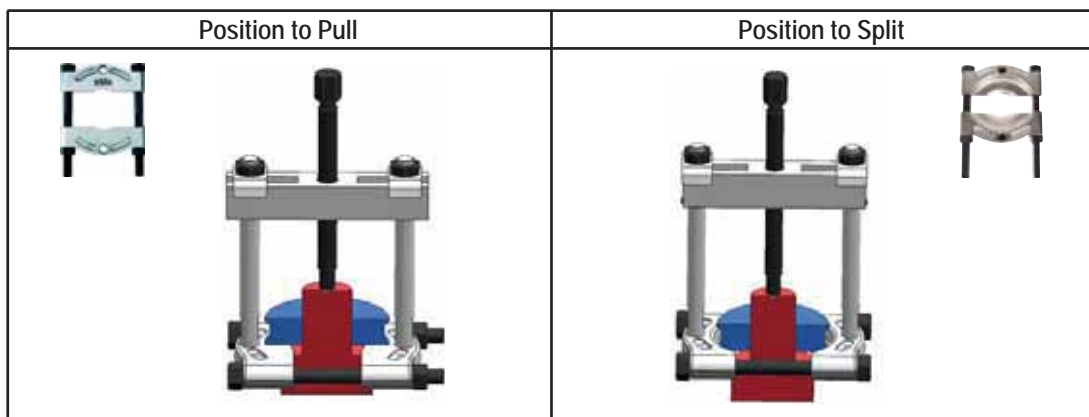

Note: Be sure to use the correct position for the required action in order to avoid damaging the Splitter-Set.

Punch, chisel & hex key sets



< M9009

Ball End Hex Key set - 4 Pc

M9009: 200mm(L) x 70mm(W) x 30mm(H)

Content

Ball End Hex Key : H1.5 - H2 - H2.5 - H3 - H4
H5 - H6 - H8 - H10

Material : CR-V



M9506 >

Pin Punch set - 6 Pc

Content :

Pin Punch (mm) : 2x115, 3x125, 4x150
5x165, 6x180, 8x180

Material : 60SICRV(T61)



< M9516

Punch & Chisel set - 16 Pc

Content :

Pin Punch (mm) : 2x110, 3x120, 4x125, 5x135, 6x145
Centre Punch (mm) : 3x125, 5x150
Taper Punch (mm) : 2x135, 3x145, 4x150, 5x160, 6x170
Chisel (mm) : 10x140, 13x150, 16x165, 19x175

Material : 60SICRV(T61)

Wrench, Twist drill bits & Oil drain plug key set

M3817 >

3/8"Dr. Oil Drain Plug Key set - 17 Pc

Content :

Square (mm) : S8 - S9.5 - S10 - S10.5 - S11 - S12 - S13.1

Hex : H8 - H9 - H10 - H12 - H13 - H14 - H17

Triangle (mm) : XT10

Square Hole (mm) : XS10

Star (mm) : M16

Material : CR-V



M1700 >

Twist drill bits set - 170 Pc

M1700 : mm(L) x mm(W) x mm(H)

A (mm)	B (mm)	C (mm)	pcs
1.0	12	34	10
1.5	18	40	10
2.0	24	49	10
2.5	30	57	10
3.0	33	61	10
3.6	39	70	10
4.0	43	75	10
4.5	47	80	10
5.0	52	86	10
5.5	57	93	10

A (mm)	B (mm)	C (mm)	pcs
6.0	57	93	10
6.5	63	101	10
7.0	69	109	10
7.5	69	109	10
8.0	75	117	10
8.5	75	117	5
9.0	81	125	5
9.5	81	125	5
10.0	87	133	5

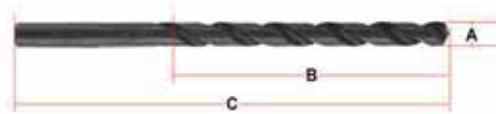

M0001 >

Wrench with Bottle Opener - 8mm



Tyre bead seater & Heavy duty pry bars



< M5001

Tyre Bead Seater

Specification :

Capacity : 20 Liter

Weight : 11.8 kg / 26 lb

Quick-release 1.5" Butterfly Valve

Heavy duty pry bar with textured handle and hammer cap

M9004 >

Pry Bar set - 4 Pc

Content :

L - 200 mm : 6.35 mm

L - 300 mm : 9.50 mm

L - 450 mm : 11.1 mm

L - 560 mm : 12.7 mm



M9036 : 5/8" x 36" - 30° / 16 x 915mm

M9048 : 7/8" x 48" - 30° / 22 x 1220mm

M9056 : 1" x 56" - 30° / 25.4 x 1422mm



Death blow hammer & magnetic holders

M9930 >

Dead-Blow Hammer - 4KG, lenght 762mm

Packing Specification :

N.W.=16.3 kgs / G.W.=18.2 kgs / Carton=4 pc / CBM=0.048



M9911 >

MMagnetic Holder

- Flexible shape.

- Easy to use from vertical to horizontal surface.

Packing Specification :

N.W.=11 kgs / G.W.=12 kgs / Carton=96 pc / CBM=0.045



M9922 >

Magnetic Holder

- For (air) impact wrench & sockets, markers, torque wrench & other tools.

- 400 mm Magnetic hook "O" + "U"

Packing Specification :

N.W.=12 kgs / G.W.=13 kgs / Carton=1 pc / CBM=0.018

M9900 & M9901 >

Magnetic Tool Strips

- Magnetic on both sides for easy use on metal surface.

- Can also be fixed on a wall with screws.

- Tools are not included.

M9900 : 300mm

M9901 : 600mm

Packing Specification :

M9900 - N.W.=22.6 kgs / G.W.=23.6 kgs / Carton=10 pc / CBM=0.01

M9901 - N.W.=24.6 kgs / G.W.=25.6 kgs / Carton=16 pc / CBM=0.01



Induction heater

HR8000 >

Induction Heater set

- All packed in strong aluminum suitcase.

- Included 5 accessories.

Specification :

Voltage : 230V / 50-60Hz / 3 Amp

Power : 1500W

Content :

Induction coil (mm) : $\varnothing 19 - \varnothing 20$

Induction cable (mm) : 600

Induction coil : U-Shape

Induction pad (mm) : $\varnothing 75$





HRK8007 >

Induction Heater Coil set - 7 pc

Content :

Induction coil (mm) : ø13 - ø19 - ø23 - ø26 - ø32 - ø38 - ø45



Hot stapler

HS7000 >



Hot Stapler set

- All packed in strong aluminum suitcase.
- Included 6 different type staples.

Specification :

Voltage : 230V / 50-60Hz / 0.15 Amp

Power : 40-50W

HS7000		Article nb
1	M-Staple (Φ 0.6mm) Outside corner	HSS7006M
2	V-Staple (Φ 0.8mm) Inside corner	HSS7008V
3	Z-Staple (Φ 0.6mm) Stitch tears	HSS7006Z
4	Z-Staple (Φ 0.8mm) Stitch tears	HSS7008Z
5	S-Staple (Φ 0.6mm) Large surface	HSS7006S
6	S-Staple (Φ 0.8mm) Large surface	HSS7008S

Auto body repair tools

M9907 >

Rubber Dolly set - 7 pc

M9907: 340mm(L) x 178mm(W) x 38mm(H)

Content

- Heel Dolly
- Long Type Heel Dolly
- Double End Dolly
- Curved Dolly
- Utility Dolly (General purpose dolly)
- Double End Hand Dolly
- Long Type Curved Dolly



Packing Specification :

N.W.=20.5 kgs / G.W.=21.5 kgs / Carton=3 pc / CBM=0.05

M9807 >

Dolly & Hammer set - 7 pc

- Full polished.

- Drop forged steel dollies & hammers.

M9807: 340mm(L) x 178mm(W) x 38mm(H)

Content

- Standard Bumping Hammer
- Pick & Finish Hammer
- Shrinking Hammer
- Utility Dolly
- Curved Dolly
- Heel Dolly
- Toe Dolly



Packing Specification :

N.W.=30 kgs / G.W.=31.2 kgs / Carton=4 pc / CBM=0.07

M9916 >

Ball Pein Hammer - 685g

Specification :

Hammer Head - 450g

Lenght - 325mm



Packing Specification :

N.W.=28.1 kgs / G.W.=29.4 kgs / Carton=36 pc / CBM=0.029



< M9924

Ball Pein Hammer - 1000g

Specification :

Hammer Head - 680g

Lenght - 384mm

Packing Specification :

N.W.=25.6 kgs / G.W.=27.1 kgs / Carton=24 pc /

CBM=0.03

Mechanix display unit

M9999 >

Mechanix Display Unit

- Tools are not included.

M9999 : 945mm(L) x 500mm(W) x 2320mm(H)

Content :

Back Pannel : 2320 x 945mm

Bottom Shelf : 915 x 385 x 32mm

Shelf : 915 x 385 x 32mm

Hooks : 50 x 3" - 50 x 4"

Optional :

M9999 - S : Shelf for display, included supports.

M9999 - 03 : Box for 50 hooks - 3"

M9999 - 04 : Box for 50 hooks - 4"

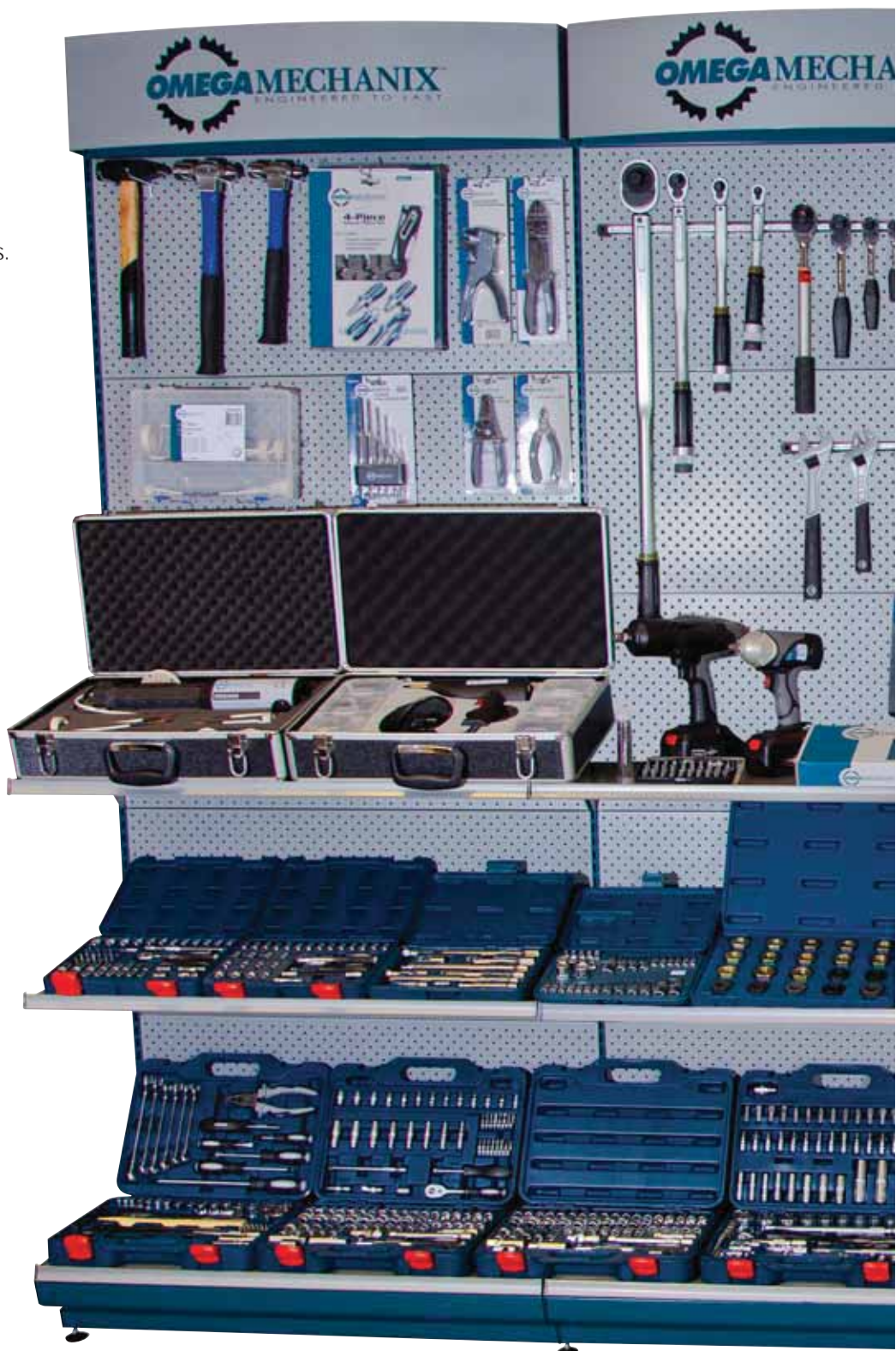



Accessories



Jump starters & Battery charger	Page 124 - 126
Work mat	Page 127
Creepers	Page 128
Creepers & Roller seats	Page 129
Automatic tyre inflators	Page 130 - 131
Industrial diesel heaters	Page 132
Gas Forced heaters / LPG	Page 133
LED work light	Page 134
Work lights & cable reel	Page 135
Oil drain pans & recycling reservoirs	Page 136
Mini air guns & Air compressor	Page 137
Hand winch, Cable & Power puller	Page 138
Electric winch	Page 139
Index	Page 140 - 141

Jump starter

IJS 6000 >

Intelligent Jump Start and Mobile Device Charger

IJS 6000

- Start Current: 300A
- Peak Current: 600A
- Will start a 12 V gasoline engine (up to 5 liter) with internal-voltage of just 0.05v in a car battery

IJS 6000D

- Start Current: 350A
- Peak Current: 700A
- Will start a 12 V gasoline engine (up to 5 liter) and Diesel cars (up to 2.0 liter engine) with internal voltage of just 0.06v in a car battery
- Output 1: 5V/2A
- Output2: 12V Jump Starter
- Input: 5V/2A
- Battery Capacity: 6000mAh/22.2wh
- Operating Temperature: -20 °C ~ 60 °C
- The world's slimmest 'pocket' jump start at this power level
- High end and high capacity internal lithium-polymer battery
- Re-charge from a laptop computer or 5v USB mains charger plug (not supplied)
- 'SMART' jump start cables with thickened copper core
- 3 in 1 mobile charging cables for smartphone and tablets
- 0.5w LED torch and SOS signal
- Safe and reliable technology
- Excess demand failsafe cut-out to protect unit and car
- Microcomputer control circuitry
- Reverse polarity protection
- Output short circuit protection
- Excessive voltage protection
- Excessive current protection
- No electrical spiking
- Size: 130mm x 67mm x 15mm
- Weight: 170g
- Neoprene carry case included



Scan me for demonstration video



Jump starter



IJS 11000 >

Intelligent Jump Start and Mobile Device Charger

- Start Current: 400A
- Peak Current: 800A
- Will start all 12 V vehicles with internal voltage of just 0.06v in a car battery
- Output 1: 5V/2A
- Output2: 12V Jump Starter
- Input: 15V/1A
- Battery Capacity: 11000mAh/41wh
- Operating Temperature: -20 °C ~ 60 °C
- The world's slimmest 'pocket' jump start at this power level
- High end and high capacity internal lithium-polymer battery
- 'SMART' jump start cables with thickened copper core
- 3 in 1 mobile charging cables for smartphone and tablets
- 0.5w LED torch and SOS signal
- Safe and reliable technology
- Excess demand failsafe cut-out to protect unit and car
- Microcomputer control circuitry
- Reverse polarity protection
- Output short circuit protection
- Excessive voltage protection
- Excessive current protection
- No electrical spiking
- Size: 174mm x 75mm x 29mm
- Weight: 390g
- Neoprene carry case included



Jump starter & Battery charger

IJS 8000 >

Intelligent Jump Start and Mobile Device Charger

IJS 8000

- Start Current: 370A
- Peak Current: 750A
- Will start a 12 V gasoline engine (up to 5 liter) with internal voltage of just 0.05v in a car battery
- Output 1: 5V/2A
- Output2: 12V Jump Starter
- Input: 5V/2A
- Battery Capacity: 8000mAh/22.2wh
- Operating Temperature: -20 °C ~ 60 °C
- The world's slimmest 'pocket' jump start at this power level
- High end and high capacity internal lithium-polymer battery
- Re-charge from a laptop computer or 5v USB mains charger plug (not supplied)
- 'SMART' jump start cables with thickened copper core
- 3 in 1 mobile charging cables for smartphone and tablets
- 0.5w LED torch and SOS signal
- Safe and reliable technology
- Excess demand failsafe cut-out to protect unit and car
- Microcomputer control circuitry
- Reverse polarity protection
- Output short circuit protection
- Excessive voltage protection
- Excessive current protection

- No electrical spiking
- Size: 138mm x 76mm x 23mm
- Weight: 300g
- Neoprene carry case included



Fully Automatic Battery Charger

- Designed to increase battery performance and life. ACDelco™ Charger provides battery maintenance function that may help to recondition a battery.
- Fully automatic Pulse charging cycle.

- Charges most lead acid battery types. The ACDelco™ Charger will charge most types of lead acid batteries plus Gell, AGM, Marine type, etc.
- The charger wakes up automatically to 'top off' battery when needed.

I-7015 >

Fully automatic battery charger for 12 Volt batteries

- Fully automatic "pulse cycle" charging.
- Safety functions:
 - Reverse polarity protection.
 - Spark-proof when clips touch each other.
 - Short-circuit and over-charge protection.
- Desulfating battery plates to extend battery lifetime and increases ability of taking charge.
- User friendly "connect & standby" operation for DC cable.
- Charging rate 2/4/6 Amp.
- Battery maintenance/reconditioning function reactivates flooded & sulfated lead-acid batteries.
- Reinforced activation function.
- Battery tester for quick battery trouble shooting.
- Auto wake-up function (Stage 4).
- 4-Stage pulse charging.
- Multiple battery charge function.
- Charging rate: 2/10/20/30/40Amp.



C-9802 >

2 fold EVA kneel pad

Size: 450x210x30mm

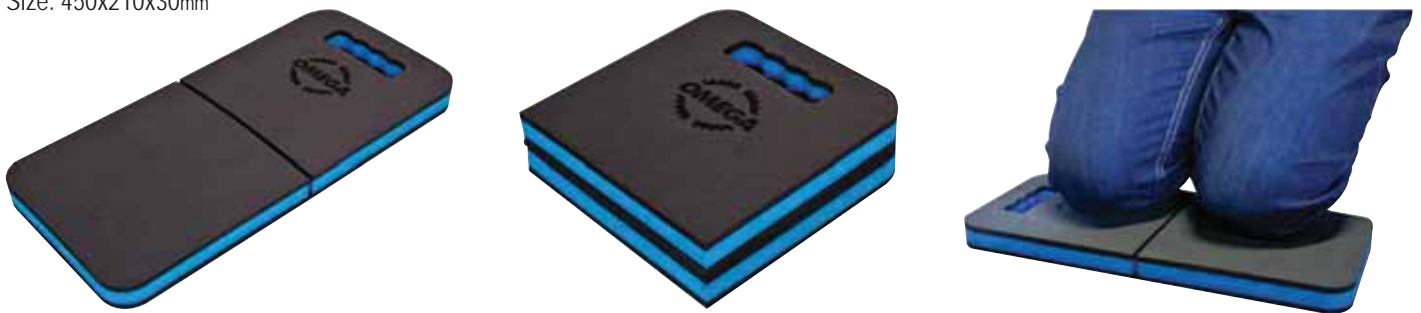

C-9803 >

3 fold EVA work mat

Size: 1210x420x30mm

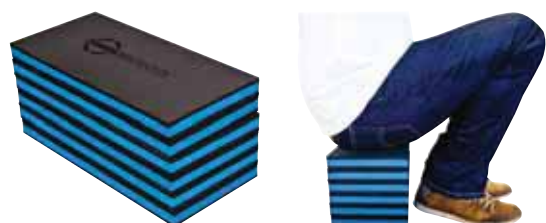
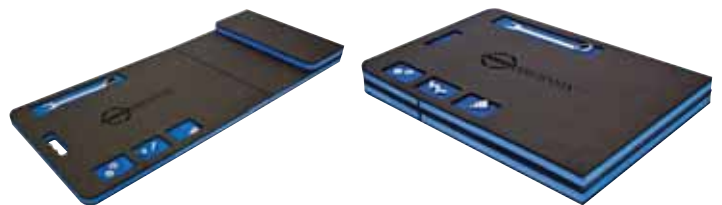

< C-9806

6 fold EVA work mat

Size: 1210x420x30mm



Creepers

CP4031 >

Bone-ster

Size: 1092x594mm

The Bone-ster double-ribbed one-piece body gives an incredible 182 Kg capacity. The Bone-ster features strong, custom molded 7,6cm diameter wheels with molded in place 2,25cm wide tyres.



< CP6031

The Bone

Size: 1194x648mm

The Bone has custom-molded 13 cm diameter wheels. With 2,5 cm wide tyres. The heavy American made steel caster frames have dual-race ADJUSTABLE ball bearing swivels and are thrubolted to the creeper body. The original Bone creeper sets the standard for the highest quality, best working creeper ever made that supports users up to 136 kgs less than 4,5cm off the ground.

CP7031

The Rough Rider with profiled 13,6 cm wheels with 3,5 cm wide tyres for outdoor use. Ground clearance 7,3 cm.



CP5031 >

The Tail Bone

Size: 806x711x584mm

The Tail Bone is designed to be easier to use, more comfortable, more durable and a better value than any other mechanic's stool on the market. The extra wide (81,3cm) uniquely designed tripod base, a naturally stable working platform, even on uneven surfaces. The entire stool swivels with your body. The Tail Bone cruises around at a low 30,5cm off the ground, making it the perfect height for any job that requires you to get low! The Tail Bone has wide (2,5cm) custom-molded, 13cm diameter wheels. Capacity 159 Kg.

Also available with outdoor wheels



Creepers & Roller seats

CP-9605 >

120cm (47") Professional Creeper

- Converts easily from creeper to seat or from seat to creeper.
- Finger safe and friendly (un-)lockingsystem.
- Soft Vinyl Padded.
- Heavy Duty Metal Frame.
- Six Ø 6cm swivel castors for smooth operation.
- Creeper 120cm / Seat 48cm high.



C-9836 >

102cm (40") Professional PVC Creeper

- Six Ø 7.5cm PVC castors.
- Storage compartments for tools, bolts/nuts.
- Incorporated grip.
- Molded to body shape for extra comfort.



< RS-9833

Pneumatic roller seat with one tray.

- Seat Ø 31cm.
- Seat adjustable in height from 38-51cm.
- Convenient tool tray allows you to keep what you need within arms reach.
- Extra 360° rotating tool tray for added storage space for tools, bolts/nuts.
- Innovative five Ø 6cm castors design.

Automatic tyre inflators

The Omega Mechanix ATI has special features that not only saves labor and improves the safety of your employees, it also prevents damage and/or inefficient use of the material/equipment of your customers. This device is one of the safest of its kind. The OPS (over pressure system) is an extra feature that allows to inflate with extra pressure to set the tyre correct on the wheel. After over-pressure is reached, the pressure will go down automatically to the preset pressure.



Scan me for demonstration video

TI 10711 >

Max + recommended inlet air supply:

10 BAR / 1000 kPa

Operating pressure:

min: 0.3 BAR / 35 kPa

max: 7.0 BAR / 700 kPa

Includes:

1x controle unit

1x 10m inflator hose with optional tyre chuck

1x inflator hose storage hook

Silencer



< TI 10721 / TI 11221

Max + recommended inlet air supply:

TI 10721

10 BAR / 1000 kPa

Operating pressure:

min: 0.3 BAR / 35 kPa

max: 7.0 BAR / 700 kPa

TI 11221

15 BAR / 1500 kPa

Operating pressure:

min: 0.3 BAR / 35 kPa

max: 12.0 BAR / 1200 kPa

Includes:

1x controle unit

1x 10m inflator hose with optional tyre chuck

1x inflator hose storage hook

Emergency switch equipped with 8m cable + HAN4 = 5 pin connector

Door switch equipped with 2m cable + HAN3 = 4 pin connector

Silencer

Automatic tyre inflators

TI 11224

Max + recommended inlet air supply:

15 BAR / 1500 kPa

Operating pressure:

min: 0.3 BAR / 35 kPa

max: 12.0 BAR / 1200 kPa

4 outlets

Includes:

1x control unit

4x 10m inflator hose with optional tyre chuck

1x inflator hose storage hook

Emergency switch equipped with 8m cable + HAN4 = 5 pin connector

Door switch equipped with 2m cable + HAN3 = 4 pin connector

Silencer



Door switch

TI-10721 - TI-11221 - TI-11224

Emergency switch

TI-10721 - TI-11221 - TI-11224

TI 00001 >

Tyre chuck

Screw in the core valve with the tyre chuck.

No air loss / no pressure loss

Easy and safe



TI 00003 >

Tyre chuck with silencer

Deflating of the tyre with the tyre chuck with 25% noise reduction.



Industrial diesel heaters

- Mobile air heater
- Operate on diesel oil or kerosene
- Stainless steel combustion chamber with fan cooling
- With flame sensor
- When out of oil, heater will cut off the power
- Fixed Oil display
- Cut-off protection, re-plugged in will not work automatically
- Low pressure atomization, combustion completely
- Waterproof class IPX4

Certificates: CE /RoHS



< HRD70

Heating output 70,000 BTUs (20.52 KW)

Fuel consumption: 1.7 kg/h (Tank 24 L)

Air output: 600 m3/h

HRD100 >

Heating output 100,000 BTUs (29.31 KW)

Fuel consumption: 2.5 kg/h (tank 24 L)

Air output: 720 m3/h



Gas Forced heaters / LPG

- Portable air heater
- Operate on propane gas (LPG)
- With over-heating protection
- Special nozzle, with strong oxygen supply make combustion complete
- Cut-off protection avoid gas leaking
- Deflation and ignition operate design
- Ideal for construction sites, utility/farm buildings, sports events, barns and factories
- Ignition: piezo
- 1.5m hose included

Certificates: CE /RoHS



< HRP42

Heating output 42,000 BTUs (12.31 KW)

Fuel consumption: 0.74 kg/h Air output: 320 m3/h

HRP100 >

Heating output 100,000 BTUs (29.31 KW)

Fuel consumption: 2.18 kg/h

Air output: 650 m3/h



LED work light



< PL-1001

Rechargeable Pocket Light - SMD LED, with Magnet

- LED: 24 SMD LED, On / Off Switch with full bright, half bright light
- Luminous Flux: 240 LM for full-bright, 120 LM for half bright.
- Battery: 3.7V, 1100mAh Lithium- Polymer battery
- Operating time: 1.5 hours for full-bright, 3 hours for half-bright.
- Charging time: 2-2.5 hours
- Protection: Over charge, over discharge and auto shut off function.



Orange
PL-1001/O



Black
PL-1001/B



Green
PL-1001/G



< PL 1007

Rechargeable stripe LED Worklight

- Stripe LED
- Magnetic Base.
- 3,6V Li-ion Battery.
- Adjustable in many positions.
- Charging time: Approximately 1.5 Hours.
- Operating time: Approximately 3.5 Hours.

LED work light & cable reel



< PL-1016

LED hand lamp

- 3W COB LED hand lamp
- Provides a wide angle beam of 205 LM
- Battery: 3.7V Li-ion 2200mAh 8.14 Wh
- Operating time: 3-3.5 hours
- Charging time 4.5-5.5 hours
- The light can be charged in the charging base as well as directly with the adaptor.
- 360° swivel hanging hook / belt clip incl . magnet

PL-511 >

11 Watt, Transistorised AC Double Fluorescent TL Work Light

- 230 Volt AC, 50Hz.
- Hanging Hook.
- VDE Plug Input
- 5 Meter VDE Cord.
- On/Off Switch with Cover.
- Water Resistant (IP44)



PL-530 >

30 Watt T8 Engine Work Light Fluorescent Lamp

- Adjustable mounting clamps 1,15 – 1.80 meter.
- Aluminium Frame with metal end covered by EVA.
- End of light and hook are PP.
- 5 meter cable.
- 230V-50Hz, VDE Plug.
- CE certificate.



PL-1200C >

Cable Reel

- Plug & Socket.
- Input Cable: 1M, 3x1.5mm².
- Output Cable: 12M, 3x1.5mm².
- Voltage: AC230V 50Hz.
- Maximum Load: - Coiled up 900W.
- Unwound 2300W.



Oil drain pans & recycling reservoirs



< PO-08

Oil drain pan

Capacity: 8 Liter

Size: 500 x 400 x 125mm

Approximate (inner) Diameter: 345mm

- High density polyethylene.
- Large handles and integrated pouring spout.
- Handles for left and right handed use.
- Multi functional (oil / antifreeze / other liquids).

Packing specification:

Carton: 20 - N.W.(Kgs): 10.8 - G.W.(Kgs): 12.3 - CBM: 0.161

PO-16 >

Oil drain pan

Capacity: 16 Liter

Size: 570 x 470 x 150mm

Approximate (inner) Diameter: 410mm

- High density polyethylene.
- Large handles and integrated pouring spout.
- Handles for left and right handed use.
- Multi functional (oil / antifreeze / other liquids).

Packing specification:

Carton: 17 - N.W.(Kgs): 16.2 - G.W.(Kgs): 17.7 - CBM: 0.221



< PO-10

Oil recycling reservoir

Capacity: 10 Liter

Size: 567 x 321 x 126mm

- Double Function: Oil drain pan & recycling reservoir.
- Large handles for left and right handed use.
- Multi functional (oil / antifreeze / other liquids).

Packing specification:

Carton: 10 - N.W.(Kgs): 10 - G.W.(Kgs): 12 - CBM: 0.204



PO-44 >

Oil recycling reservoir with wheels

Capacity: 44 Liter

Size: 885 x 495 x 188mm

- Double function: Oil drain pan & recycling reservoir.
- Large handles for left and right handed use.
- Wheels for easy and light handling.
- Multi functional (oil / antifreeze / other liquids).
- Small holes under the drain cap to prevent small parts from falling into the reservoir.

Packing specification:

Carton: 4 - N.W.(Kgs): 16.4 - G.W.(Kgs): 19.4 - CBM: 0.351



Mini air guns & Air compressor

M1401 >

1/4" PT Air blow gun with quiet safety nozzle



PA-01 >

Mini air blow gun

- Nozzle with safety tip.
- Thanks to the extra holes in the nozzle you get an even and safe airflow.
- Body material: Nylon.
- Nozzle material: Brass.
- Working pressure: 90 PSI (0.6 MPa).
- Sound level: 70 dBA.
- Air consumption (90 PSI/6.2 BAR): 164 Liter/Min.
- Temperature range: - 20°C ~ 70°C.
- Air inlet:
 1. Thread type: 1/4"NPT or 1/4"PT.
 2. Plug material: Steel.



< PA-02

Mini Air Blow Gun with Turbo Tip.

- The turbo-tip creates a stronger air output.
- Body material: Nylon.
- Nozzle material: Brass.
- Working pressure: 90 PSI (0.6 MPa).
- Sound level: 83 dBA (W/O Turbo Tip: 75 dBA).
- Air consumption (90 PSI/6.2 BAR): 381 Liter/Min.
- Temperature range: - 20°C ~ 70°C.
- Air inlet:
 1. Thread type: 1/4"NPT or 1/4"PT.
 2. Plug material: Steel.



W2001 >

High Flow Air Compressor.

- Pressure Max. 7 BAR (100 PSI).
- Air flow 30 LPM.
- Large and powerful motor to provide robust performance.
- Supply cord with alligator clips.
- Build-in pressure gauge.
- Build-in amber color warning light.
- ON/OFF switch for compressor and warning light.
- Sturdy housing for rough usage.
- Two nozzles adaptors for inflatables; one needle adaptor for sport balls.
- Air hose with V8 connector.
- Plug with 15A fuse for protection.
- Alligator cable assembly with lighter socket.
- Connect direct to the car battery.



Hand winch, Cable & Power puller

2119086, 2119087, 2119089 >

2119089: 2000Kg Handwinch with Handbrake

2119086: (not shown) 960Kg Handwinch

2119087: (not shown) 1500Kg Handwinch

- Solid Gear Construction.
- Black electrostatic discharge coating finish for resistance to corrosion and weather condition.
- Internally lubricated drum and pinion gear bushings.
- Precise gear tooth engagement.
- Smoothly rotating handle.
- Reinforcement in frame for added strength.

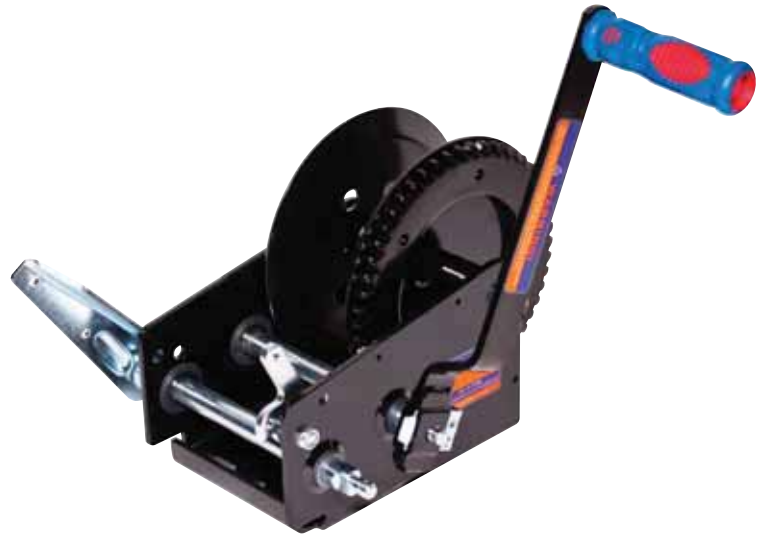

	2119086	2119087	2119089
Max. pulling capacity	960kg	1500kg	2000kg
Working capacity	320Kg	500kg	650kg
Gear ratio	4:1	4:1	5:1/12:1
Solid gear construction	✓	✓	✓
Black coated finish	✓	✓	✓
Precise gear tooth engagement	✓	✓	✓
Gear	1 gear, 2 way, 1 speed design	2 gear, 2 way, 1 speed design	1 gear, 2 way, 2 speed design
Package	1 set/color box	1 set/color box	1 set/color box



< 2119088

10m wire cable

- Nominal Breaking Load: 1,905kg.
- Galvanized Aircraft Cable with one forged hook.
- Package: 1pc / plastic bag.
- Diameter 5mm
- Cable Length 10m

2119077, 2119080 >

2119077: 4000 Kg Double gear hand power puller

2119080: 2000 Kg Double gear hand power puller

- One piece body frame construction chrome/zinc plated and polished to resist rust.
- Drop forged hanging bracket swivel 360° for all positions.
- Drop forged steel hook with spring safety latch.
- Easy to reach cable release works one notch at a time for maximum safety.
- Heavy polished steel ratchet arm for smooth non-binding operation.
- Heavy-Duty stamped steel provides added strength in ratchet wheel, drive pawl and stop pawl.
- Heat treated heavy-duty bolts in handle & body.
- Heavy-Duty galvanized aircraft cable.
- Heavy-Duty metal safety shield.



U0705 >

Electric Winch

Rolling Load Capacity 5000kg (double line) / 3000kg (single line)

Rated Single Pull

First Layer 560 kg

Half Spool 410 kg

Full Spool 230 kg

Single Line Speed

Full load - 35cm/min

No load - 85cm/min

Doubleline speed is half of single line specifications.

FEATURES:

- Wide outdoor applications - Boat launching, lawn and garden work or vehicle emergency use.
- Capable of handling rolling loads up to a capacity of 3.000 kg. Maximum rolling loads of 500 kg at 45° upward.
- Mechanical self-brake system automatically brings winch to a standstill when winch is set off.
- Adaptor plate attached for winch mounting on flat surface capable of sustaining rated load.
- Standby emergency hand crank equipped for use on low battery occasion.
- Optional pulley block available for handling rolling load up to 5.000 kg.
- Cable length 13m.



1		24601	23 + 24	46060	31	AMP230710	110	HSS7006S	118
10300	8 + 9	2501503	13 + 15	46100	31	AMP230810	110	HSS7006Z	118
10500	8 + 9	2505700	16 + 18	47020	46 + 47	AMP320202	111	HSS7008S	118
10990	8 + 9	2510700	16 + 18	47053	46 + 47	AMP320303	111	HSS7008V	118
1102500	8 + 9	2602701	11 + 14	5		AMP321004	111	HSS7008Z	118
1104500	8 + 9	2702701	11 + 14	50040	34	AMPC230110	110	I	
1106500	8 + 9	28045	13 + 15	50100	34	AMPC230410	110	I-7015	126
1108500	8 + 9	2902301	12 + 15	55040	48 + 49	AMPC230710	110	IJS6000	124
1112500	8 + 9	2902401	10 + 14	55049	48 + 49	APS1202	111	IJS6000D	124
1112900	8 + 9	2902501	12 + 15	55100	48 + 49	APS1203	111	IJS8000	126
1120500	8 + 9	2903011	11 + 15	55109	48 + 49	APS1204	111	IJS11000	125
1120900	8 + 9	2903101	10 + 14	6		B		M	
1412000	8 + 9	2903201	12 + 15	60253	40 + 41	B0200	52	M0001	113
1420000	8 + 9	2903501	10 + 14	61025	40	B0400	52	M0003	86
1430000	8 + 9	2903701	11 + 14	61154	40 + 41	B0600	52	M0006	71
1202100	8 + 9	3		61204	40 + 41	C		M0012	70
1204100	8 + 9	31000	38 + 39	61304	40 + 41	C1001	58	M0013	70
1730200	8 + 9	3203100	28 + 30	61504	40 + 41	C-9802	127	M0017	73
1820200	8 + 9	3203500	28 + 30	65124	42 + 43	C-9803	127	M0023	68
1820600	8 + 9	3203900	29 + 30	6615000	44	C-9806	127	M0027	69
1850200	8 + 9	3206100	28 + 30	7		C-9836	129	M0029	69
2		3206500	28 + 30	71055	48 + 49	CP4031	128	M0032	108
2102701	12 + 15	3207500	29 + 30	71105	48 + 49	CP5031	128	M0034	85
2103001	10 + 14	3210901	29 + 30	9		CP6031	128	M0043	85
2119077	138	3212100	28 + 30	90068	38 + 39	CP7031	128	M0048	69
2119080	138	3212500	28 + 30	90150	35 + 36	CP9605	129	M0060	108
2119086	138	3220100	28 + 30	90165	38 + 39	F		M0078	73
2119087	138	3222500	29 + 30	90250	46 + 47	F2000	53 + 55	M0105	80
2119088	138	4		9210000	44	F2000 B	53 + 55	M0119	83
2119089	138	41000C	32 + 33	A		F5210	53 + 55	M0121	86
22101C	17 + 18	41001	32 + 33	A1000	58	F7670	53 + 55	M0122	86
22201	17 + 18	41100C	32 + 33			G		M0127	68
22903	48 + 49	41901	31	AMP120310	110	G1250	54 + 55	M0138	108
22910	46 + 47	4200000	32 + 33	AMP120315	110	G2250	54 + 55	M0141	86
23152	19 + 24	42001	32 + 33	AMP120720	110	G2500	54 + 55	M0142	86
23205	22 + 25	43000	33	AMP120725	110	G3002	54 + 55	M030N	96
23207	22 + 25	44012	35 + 37	AMP121230	110	H		M0381	86
23211	22 + 25	44017	35 + 37	AMP121235	110	HR8000	116	M0382	86
23212	20 + 24	44018	35 + 37	AMP121240	110	HRD70	132		
23301C	23 + 25	44020	36 + 37	AMP121550	110	HRD100	132	M110N	96
23501	23 + 25	44943	36	AMP221102	111	HRK8007	117	M1000N	96
23991	23 + 25	44947	36	AMP221103	111	HRP42	133	M1208	84
24113	21 + 24	44949	36	AMP221110	111	HRP100	133	M1209	84
24213	21 + 24	44980	36	AMP230110	110	HS7000	118	M1217	103
24301	23 + 24	46030	31	AMP230410	110	HSS7006M	118	M1219	97

M1228	78	M3206	105	M7809	87	M9438	92	SB001B	26
M1234	84	M3211	103	M7810	87	M9455	92	SB001Y	26
M1256	82	M3215	107	M7811	87	M9506	112	SB002B	26
M1297	77	M3232	106	M7812	87	M9516	112	SB002Y	26
M1395	76	M3234	103	M7813	87	M9703	105	SP44410	27
M1401	137	M3314	102	M7814	87	M9706	104	SP55415	27
M1443	74	M3316	102	M7815	87	M9711	104	SP66420	27
M1500	81	M3322	102	M7816	87	M9737	104	SP66625	27
M1500N	97	M3350	65	M7817	87	M9807	119	SP1010650	27
M1700	113	M3379	65	M7818	87	M9900	115	SW001B	26
		M3397	65	M7819	87	M9901	115	SW002B	26
M2008	109	M3414	78			M9907	119	T	
M2012	70	M3424	97	M8000	73	M9911	115	T2002	56
M2016	100	M3500-MDF01	62	M8011	73	M9916	119	T3003	56
M2020	109	M3531	62	M8015	79	M9922	115	T3004	56
M2033	101	M3591	64	M8104	70	M9924	119	T5350B	57
M2034	100	M3593	64	M8107	72	M9930	115	TI-00001	131
M2038	101	M3760	63	M8203	71	M9999	120+121	TI-00003	131
M2041	101	M3770	62 + 63	M8204	71	M9999-03	120+121	TI-10711	130
M2042	101	M3808	105	M8207	72	M9999-04	120+121	TI-10721	130
M2060	98	M3817	113	M8304	71	M9999-S	120+121	TI-11221	130
M2062	99	M3852	75	M8306	72			TI-11224	131
M2063	98			M8308	72	MD02	66	U	
M2064	98	M500N	96			MD12	66	U0705	139
M2072	97	M5001	114	M9004	114	MD15	67	W	
M210N	96	M5713	79	M9009	112	P		W2001	137
M2212	94			M9036	114	P0501	59		
M2214	94	M7320	97	M9048	114	PA-01	137		
M2238	94	M7580	87	M9056	114	PA-02	137		
M2305	88	M7583	87	M9104	90	PL-1001B	134		
M2308	88	M7584	87	M9304	92	PL-1001G	134		
M2312	88	M7585	87	M9305	94	PL-1001O	134		
M2339	90	M7586	87	M9306	94	PL-1007	134		
M2402	87	M7587	87	M9307	95	PL-1016	135		
M2405	89	M7588	87	M9308	94	PL-1200C	135		
M2408	89	M7589	87	M9383	95	PL-511	135		
M2412	89	M7591	87	M9393	95	PL-530	135		
M2435	85	M7592	87	M9402	93	PO-08	136		
M2502	91	M7593	87	M9404	93	PO-10	136		
M2560	91	M7594	87	M9405	93	PO-16	136		
M2562	91	M7596	87	M9406	93	PO-44	136		
M2563	91	M7597	87	M9410	92	R			
		M7598	87	M9411	92	RS-9833	129		
M3203	107	M7599	87	M9414	109	S			
M3205	105	M7808	87	M9416	91	S0501T	29 + 27		

---PRESS RELEASE---

Omega Mechanix new sponsor of United Autosports

Roosendaal, The Netherlands, 30 May 2016

Omega Mechanix is one of the sponsors of United Autosports for 2016 and 2017. United Autosports is a well-known GT and sports car team, based in Leeds, West Yorkshire, UK. This year United Autosports are making their debut in the European Le Mans Series. To improve the brand awareness, the logo and the brand name of Omega Mechanix will appear on the Ligier JS P3 cars. In addition, Omega Mechanix also sponsors the GT Cup.

United Autosports

United Autosports was founded in 2009 by businessman Zak Brown and racing driver Richard Dean. United Autosports have raced in a number of different championships, with a vast range of cars and drivers. United Autosports are hugely experienced in racing in the UK and Europe, as well as worldwide, having entered events in Asia, Australia and America.





Shinn Fu Europe

"Omega Hydraulics and Omega Mechanix' workshop tools has a market leading range of workshop hydraulics equipment which is tried, tested and used by thousands of car and commercial workshops in the UK, along with hundreds of leading Fast Fit locations", United Autosports said. United Autosports sees Omega Hydraulics and Omega Mechanix as quality brands.

Events

The European Le Mans Series serves as the leading championship for endurance racing in Europe. The championship visits seven of the top race circuits in Europe for a two-day event, culminating in a four-hour race. Each event provides plenty of entertainment for the thousands of spectators that attend.

Remaining races check the website of United Autosports. www.unitedautosports.com/

---End of Release---

Contact

To learn more about this sponsorship, please contact:

Shinn Fu Europe

Munnikenheiweg 50

4879 NG Etten-Leur, The Netherlands

Office: +31-165 583 300

sales@sfeu.nl

GLOBAL LOCATIONS

www.shinnfu.com



EUROPE, AFRICA & MIDDLE EAST

Munnikenheiweg 50
4879 NG Etten-Leur
the Netherlands
Tel. +31 165-583300
Fax +31 165-583310
email: sales@sfeu.nl



AUSTRALIA & PACIFIC

15 Newtech Place
Rowville 3178, Victoria
Australia
Tel. 61 3 9755-8277
Fax 61 3 9755-8219
email: sales@shinnfuaustralia.com



ASIA

7F., NO. 408 Ruel Guang Road
Nei Hu District, Taipei City 114
Taiwan R.O.C.
Tel. 886 2 8751-7888
Fax 886 2 8751-7999
email: sales@shinnfu.com



CHINA

3950 Hu Min Road
201108, Shanghai
China
Tel. +86 21 64891469
Fax +86 21 64891465
email: sales@shinnfu.com



USA, CANADA, MEXICO, CENTRAL & SOUTH AMERICA

10939 N. Pomona Ave.
Kansas City, MO 64153
Tel. 888 332 6419, 816 891
6390
Fax 816 891 6599
email: sales@omegalift.com