

# **TBS7000RD Assembly and Operation Manual**

## **200 lb. Commercial Trail Behind Broadcast Spreader**

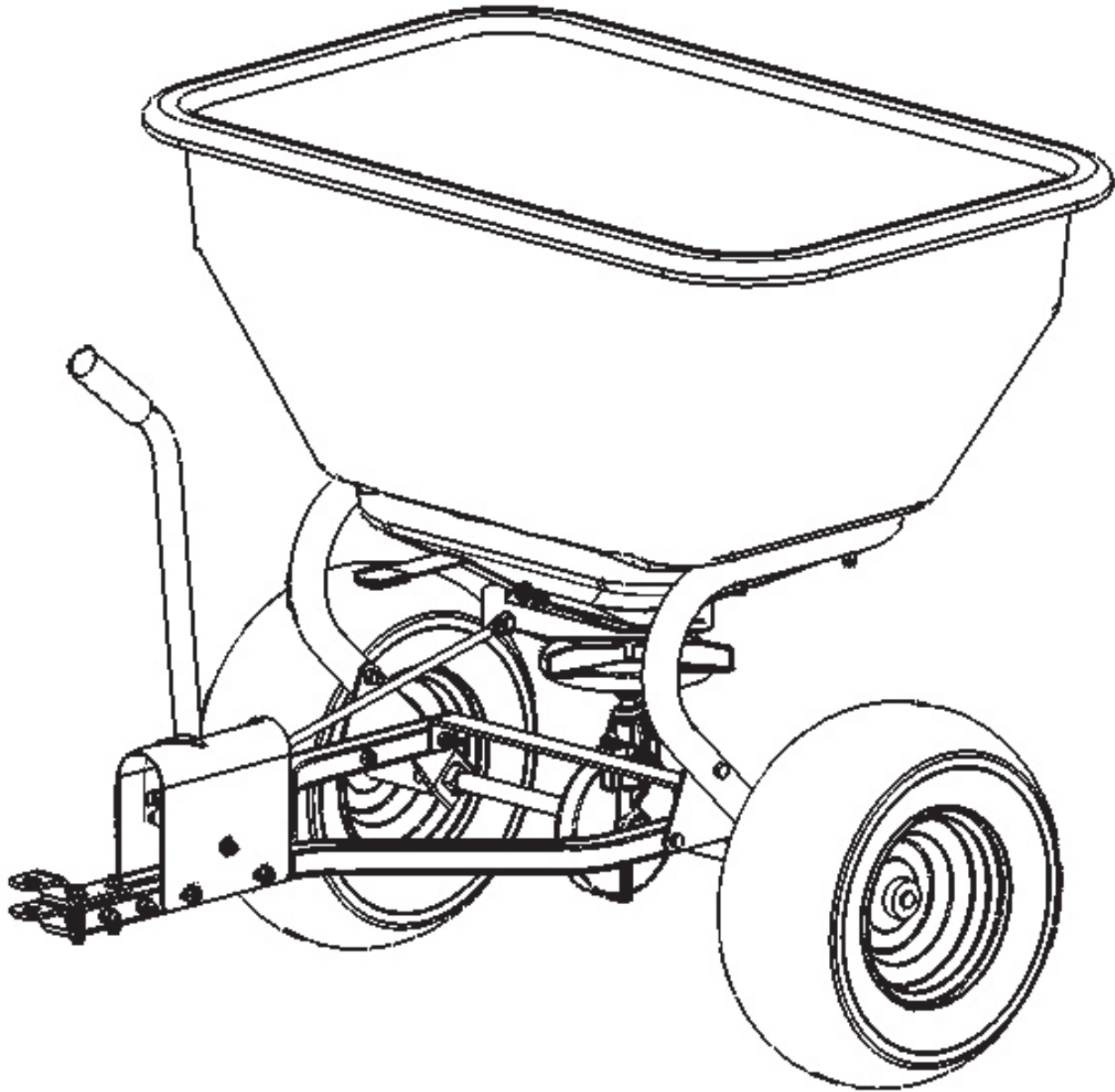

# Precision Products, Inc.

### LIMITED WARRANTY

This unit is warranted against defects in materials and workmanship to the original purchaser, under normal use and service, for a period of ninety (90) days from date of sale. During the Warranty Period, we will repair or replace at our option free of charge to the original purchaser, any part of the Unit that our examination shows to be defective in workmanship or materials. This Warranty **Does Not** apply to damage caused by transit, misuse, abuse, neglect, accident, normal wear, or alterations by unauthorized persons.

# TBS7000RD Assembly & Operation Manual

**ASSEMBLY TIP:** Loosely tighten nuts and bolts at first. Fully tighten when the spreader is completely assembled.

**Note:** Bolts on the Hitch Arm Assembly are not fully tightened to make assembly easier.

## TOOLS NEEDED FOR ASSEMBLY

- 2 - 1/2" Wrenches
- 2 - 7/16" Wrenches

## Spreader Components for Assembly

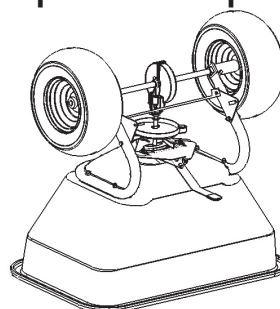

HOPPER ASSEMBLY

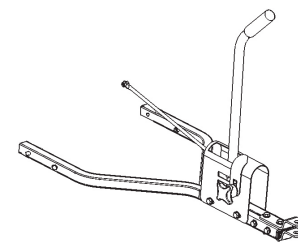

HITCH ARM ASSEMBLY

Attach the Hitch Arm Assembly to the Hopper Assembly with the 5/16" bolts pre-attached to the Hopper Assembly.

Remove the 5/16" Lock Nuts (both sides) and Cross Brace from the 5/16" x 3" Hex Head Bolts. Attach the Hitch Arm Assembly and re-insert the Cross Brace inside both sides of the Hitch Arm Assembly. Secure with the two (removed) 5/16" Lock Nuts.

Remove the 5/16" x 1-1/2" Hex Head Bolt from the Side Brackets and re-insert through (in order) the Side Bracket and Hitch Arm. Secure with the removed 5/16" Lock Nuts.

Remove the 1/4" x 1/2" Hex Head Bolt and 1/4" Lock Nut from the end of the Control Rod. Attach the Control Rod to the Slide Plate on the Hopper Assembly using the 1/4" x 1/2" Hex Head Bolt and 1/4" Lock Nut.

Tighten the four bolts used to hold the Hitch Arm and Hopper Assemblies together. Tighten the two Clevis Plate bolts and Hitch Arm end bolts.

**DO NOT TIGHTEN THE TWO CONTROL HOUSING BOLTS YET.**

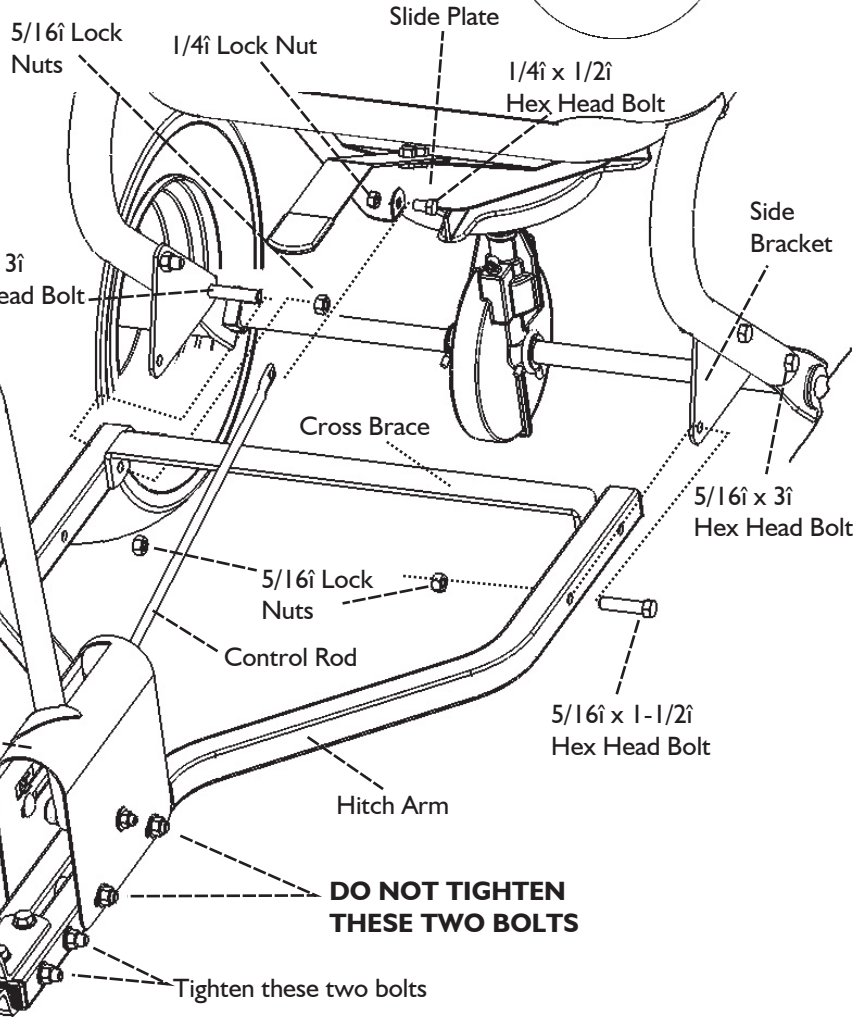
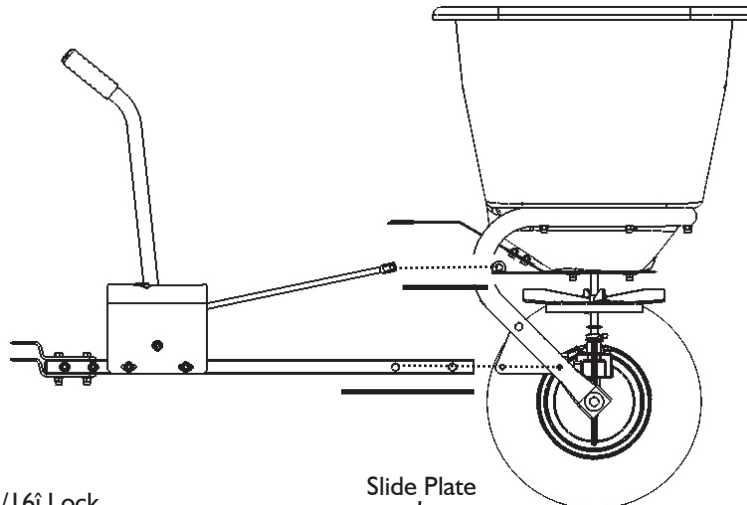
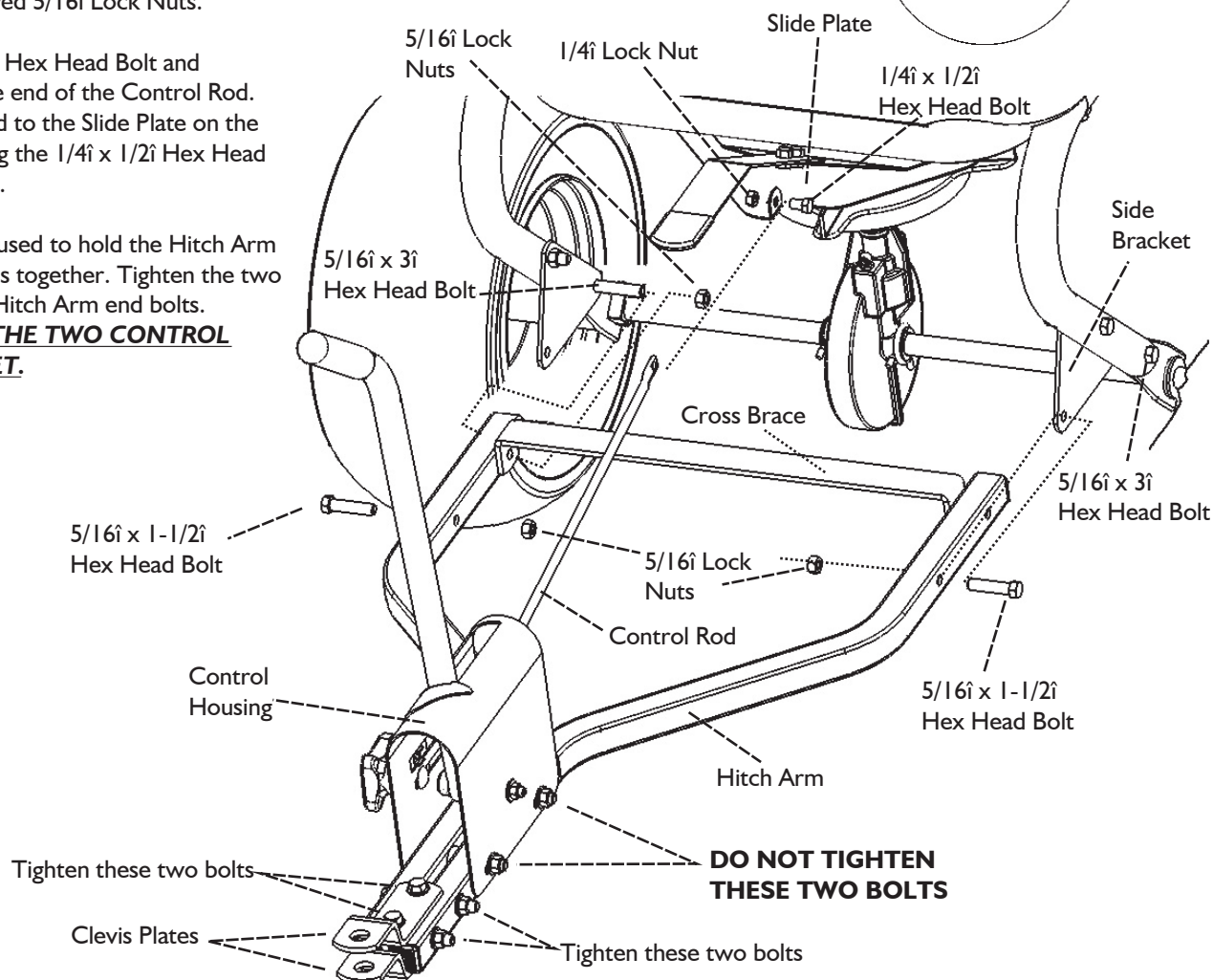

## **SLIDE PLATE / CONTROL HOUSING ADJUSTMENT**

For proper calibration, the Slide Plate must be zeroed-out first. This means that the Slide Plate must be fully closed when the Handle is in the Closed position.

Place the Handle in the closed position. Check inside the Hopper to make sure there is no gap between the Slide Plate and the Hopper opening on the bottom. If there is a gap, adjust the Control Housing either forward or back until the gap closes to the edge of the Hopper bottom. Once this is accomplished, tighten the two bolts on the Control Housing to lock the adjustment in place.

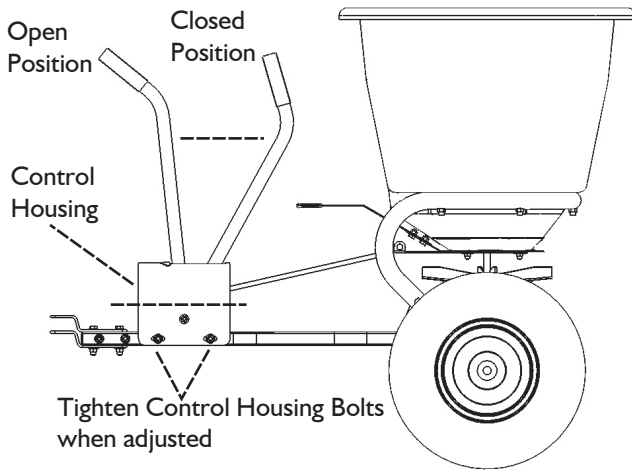

**Diagram Shows Slide Plate Half-Opened**

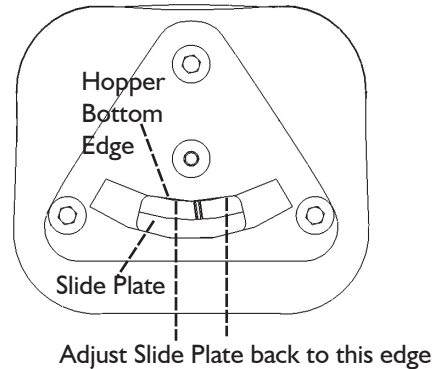

## **CALIBRATION**

The Calibration Numbers are based on pounds per 1000 square feet. These calculations are based on tests with a popular brand of fertilizer, so results may vary slightly. Calculate the amount of fertilizer that needs to be applied according to the bag of fertilizer you plan to use. To do this: first read how much the bag weighs. Divide the total bag weight by how many square feet the manufacturer says the bag will cover. Take your total (which will be pounds per square foot) and multiply by 1,000 to get your pounds per 1,000 square feet total.

For example, a 50 lb. bag of fertilizer says it will cover 15,000 sq. ft. Take 50 and divide by 15,000 and get .00333 (this number is the total for pounds per 1 square foot). Multiply .00333 by 1,000 to get 3.33. This is the total pounds per 1,000 square feet you will need to apply. Round the number down to 3, and set the Calibration Strip edge to the number 3.

After the calibration number has been determined, loosen the Control Knob and slide the (long) edge of the Calibration Strip to the desired setting. Tighten the Control Knob. **NOTE: The Calibration Strip CANNOT fully stop the Handle if opened with a great amount of force. It is there as a guide. Gently pull the Handle to the edge of the Calibration Strip, then stop.**

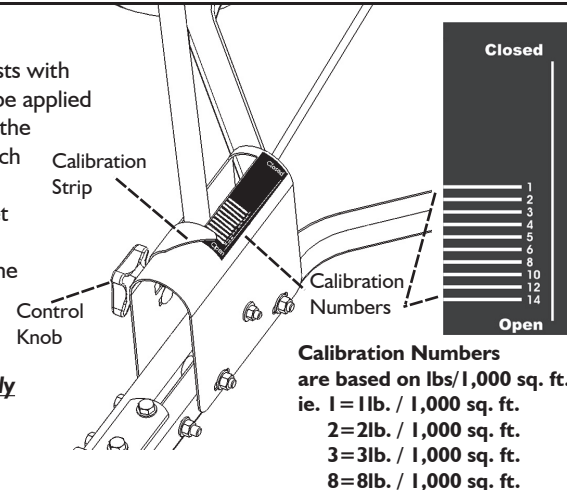

## **BROADCAST SPREADER OPERATION**

1. Always have the control lever in CLOSED position before filling the hopper.
2. Always pull the spreader forward to operate; do not operate in reverse.
3. Start moving forward before pushing the control lever to the OPEN position. Pull the control lever to OFF position before stopping or turning.

**DO NOT allow spreader to sit stationary with material in the hopper and control lever in the OPEN position.**

**If you do spill the fertilizer or feel you have over-fertilized, the antidote is plenty of water. Water pushes the fertilizer past the roots so it will not burn plants.**

4. Pull the spreader at a steady speed (approximately 3 - 4 mph is recommended).
  5. To avoid misses or striping, space each pass across the lawn so approximately 20% of the spread width overlaps onto the previous pass. This provides a feathered overlap to even out distribution over the width of the spread.
- CAUTION: care must be taken with any weed killer, pesticide, or combination product. They can be harmful to other plant life in the yard.**

**Recommended operating weight ñ 180 lbs.**

## **Free-Wheel Option**

Your TBS7000RD Spreader has a unique feature which allows the spreader to be transported over long distances, at greater speeds without wear and tear on the gear case assembly. This (free-wheel) option turns only the wheels and leaves the axle and the gear case assembly at rest. **REMEMBER: if you are traveling with a loaded hopper at higher speeds, the spreader stands an easier chance of becoming unstable and turning over. BE CAUTIOUS OF THE TERRAIN!** The more un-even the terrain is, the more you need to lower your speed.

Remove the #213 Hitch Pin Clip from the hole in the 1/4 x 1-5/8 Clevis Pin. Remove the Clevis Pin from the wheel hub. The wheel will now turn freely.

To re-engage the axle: align the hole in the wheel hub with the hole through the axle. Insert the 1/4 x 1-5/8 Clevis Pin through the hole in the wheel hub and the axle. Secure the Clevis Pin in place using the #213 Hitch Pin Clip.

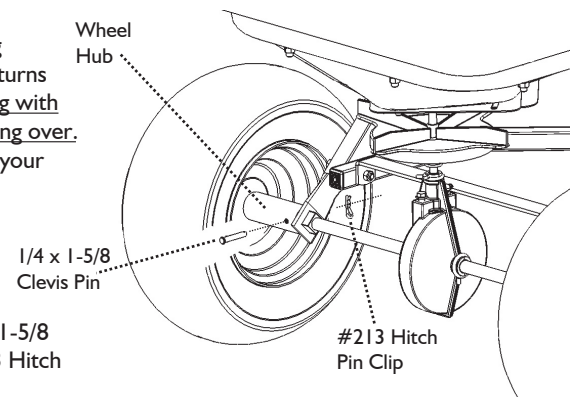

## MAINTENANCE INSTRUCTIONS

1. Empty hopper after each use. Do not store spreader with material left in hopper.
2. Wash spreader thoroughly and wipe dry.
3. Lubricate all moving parts. Use a grease gun to apply grease to the gearbox assembly. **CAUTION: Use a reasonable amount of grease. DO NOT pack gearbox full of grease.** Apply oil to spinner shaft (including area shaft extends through hopper), slide plate and where the spinner shaft and axle extend through the gearbox.

# Parts List for the TBS7000RD Spreader

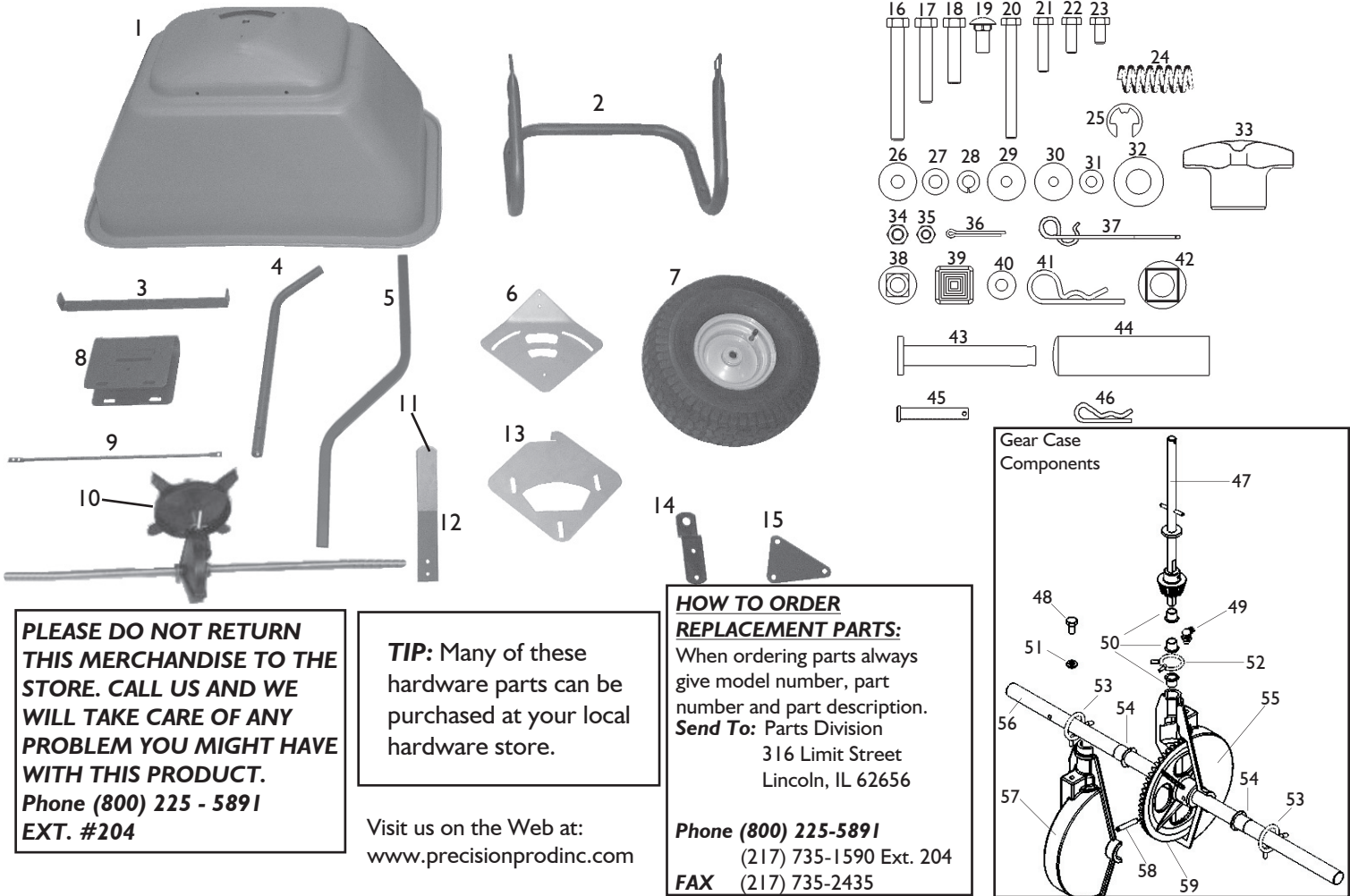

**PLEASE DO NOT RETURN THIS MERCHANDISE TO THE STORE. CALL US AND WE WILL TAKE CARE OF ANY PROBLEM YOU MIGHT HAVE WITH THIS PRODUCT.**  
**Phone (800) 225 - 5891**  
**EXT. #204**

**TIP:** Many of these hardware parts can be purchased at your local hardware store.

Visit us on the Web at:  
[www.precisionprodinc.com](http://www.precisionprodinc.com)

### HOW TO ORDER REPLACEMENT PARTS:

When ordering parts always give model number, part number and part description.  
**Send To:** Parts Division  
 316 Limit Street  
 Lincoln, IL 62656

**Phone (800) 225-5891**  
 (217) 735-1590 Ext. 204  
**FAX (217) 735-2435**

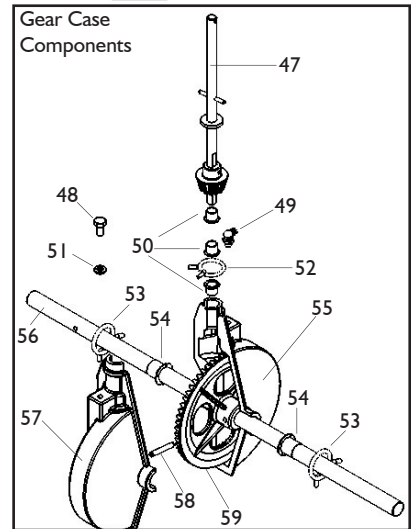

Ref No	Parts No	Description	Qty	Ref No	Parts No	Description	Qty	Ref No	Parts No	Description	Qty
1	2155	Hopper	1	21	1660	1/4 x 1-1/4 Hex Head Bolt	1	41	1042	#14 Hitch Pin	1
2	2151	Wrap Around Support	1	22	1643	1/4 x 3/4 Hex Head Bolt	3	42	2150	Axle Bearing	2
3	2154	Cross Brace	1	23	1647	1/4 x 1/2 Hex Head Bolt	3	43	4289	1/2 x 3-1/2 Clevis Pin	1
4	2162	Control Handle	1	24	2157	Compression Spring	1	44	1029	7/8 Handle Grip	1
5	2152	Hitch Arm	2	25	2175	E-Clip	1	45	2188	Clevis Pin 1/4" x 1-5/8"	1
6	2167	Spread Adjustment Plate	1	26	2172	5/16 x 1 1/2 O.D. Washer	6	46	2189	#213 Hitch Pin Clip	1
7	2409	Wheel	2	27	1044	5/16 Flat Washer	23	47	2982A	Spinner Shaft Assembly	1
8	2164	Control Housing	1	28	1276	5/16 Lock Washer	7	48	2984	1/4 x 1/2 Hex Head Bolt FT	1
9	2156	Control Rod	1	29	6143	1/4 Fender Washer	6	49	2983	1/4 Grease Zerk	1
10	2614	Spinner Disc	1	30	6127	1/4 Rubber Washer	6	50	2973	3/8 Nylon Bushing	3
11	2166	Vinyl Handle Cap	1	31	1817	1/4 Flat Washer	6	51	1807	1/4 Lock Washer	1
12	2169	Spread Adj. Plate Handle	1	32	1646	5/8 Flat Washer	4	52	2978	7/8 Spring Clamp	1
13	2168	Slide Plate	1	33	2158	Control Knob	1	53	2977	15/16 Spring Clamp	2
14	4266G	Clevis Plate	2	34	1557	5/16 Lock Nut	18	54	2970	5/8 Nylon Bushing	2
15	2153	Side Bracket	2	35	1558	1/4 Lock Nut	9	55	2976	Rear Gear Case Housing	1
16	2173	5/16 x 3 Hex Head Bolt	6	36	1262	1/8 x 1-1/4 Cotter Pin	2	56	2161	Axle	1
17	4041	5/16 x 2 Hex Head Bolt	10	37	2905	Agitator Pin	1	57	2975	Front Gear Case Housing	1
18	4014	5/16 x 1-1/2 Hex Head Bolt	2	38	2160	Spinner Shaft Bushing	1	58	2979	3/16 x 1-1/4 Split Pin	1
19	1314	5/16 x 3/4 Carriage Bolt	1	39	2176	1 1/2 Square Tube Plug	4	59	2971	Drive Gear	1
20	2179	1/4 x 3 Hex Head Bolt	1	40	2178	5/16 x 5/16 Rubber Roller	1		2171B	Strainer (Not Shown)	1
									2170	Rain Cover (Not Shown)	1