

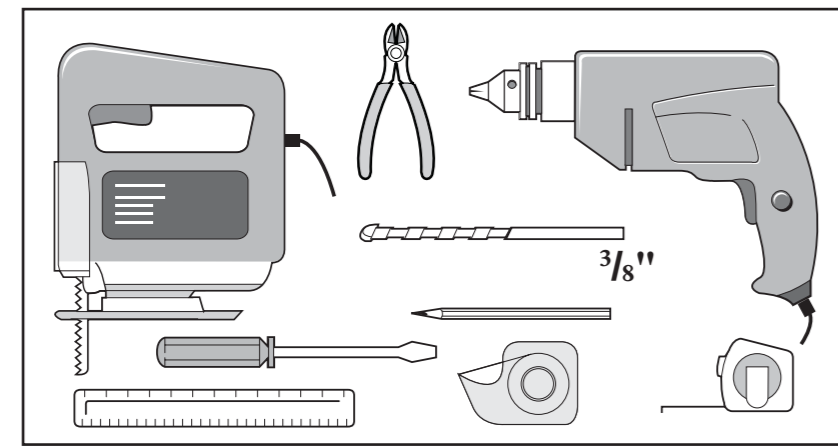

Plastic Pet Door

Installation Guide and Template

Tools required



Contents

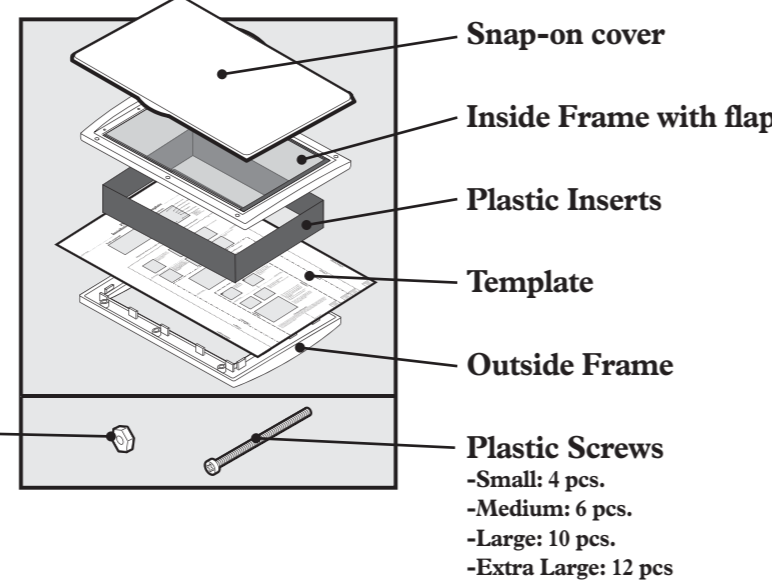

Hex Nuts
-Small: 4 pcs.
-Medium: 6 pcs.
-Large: 10 pcs.
-Extra Large: 12 pcs

Plastic Screws
-Small: 4 pcs.
-Medium: 6 pcs.
-Large: 10 pcs.
-Extra Large: 12 pcs

Important: For best results use a primer for plastics before applying your paint.

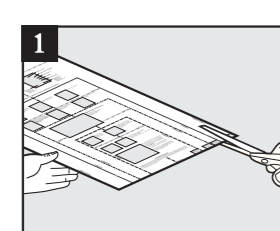

1 Cut out correct template size.
Note: If you have purchased an Extra Large Plastic Pet Door, no cutting is required.

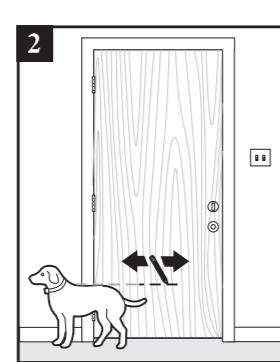

2 Measure & mark your pet's shoulder height on door.

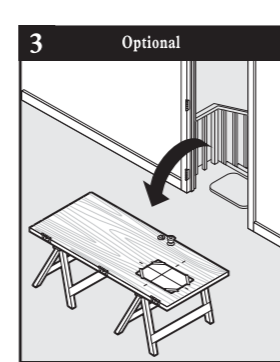

3 *Optional* Remove door (Optional)

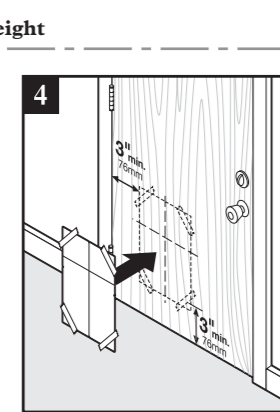

4 Match shoulder height line on door to the one on template. Draw line around the template. **Important:** From bottom and hinged side of door should be no less than 3" to opening.

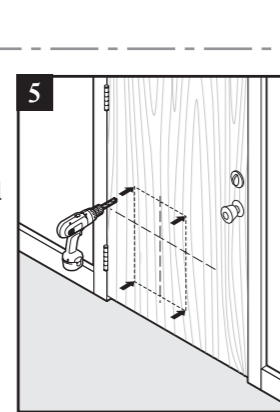

5 Drill 1/8" holes in corners (saw blade pilot hole).

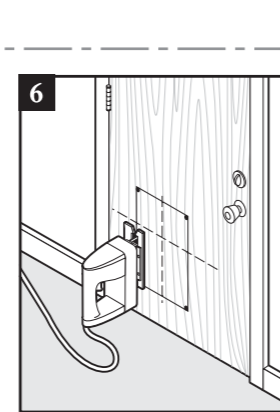

6 Cut between holes using a jigsaw.

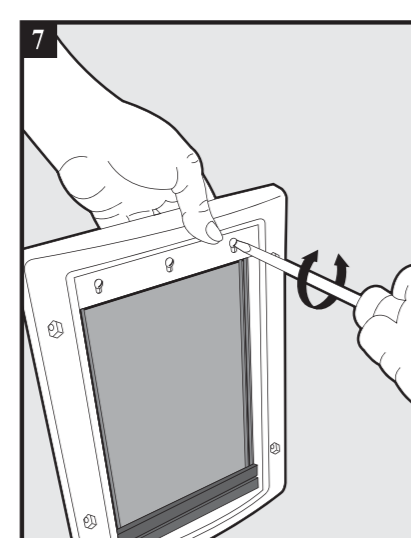

Adjust Flaps if Necessary

- Loosen screws
- Pull up to adjust flap
- Tighten screws

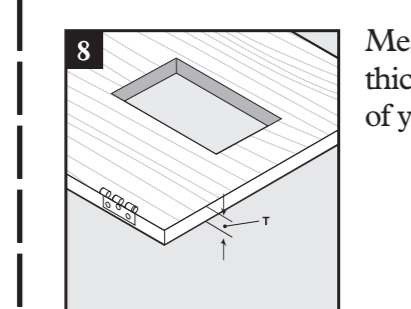

8 Measure the thickness (T) of your door.

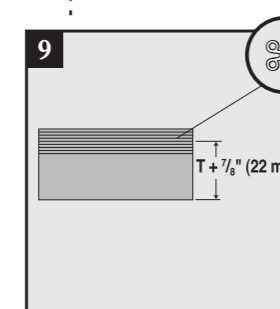

9 Cut the grooved side of plastic inserts to equal the thickness (T) of your door + 1/8".

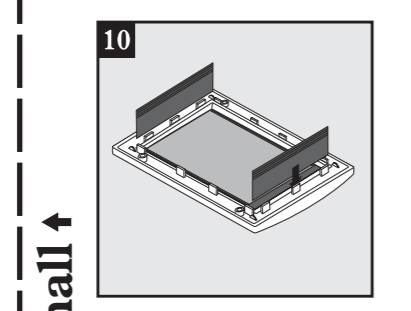

10 Place inserts in inside frame (frame with flap).

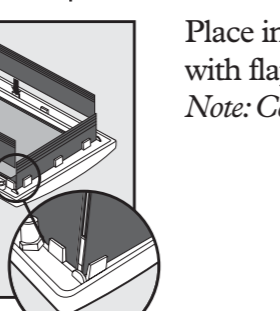

11 *Note: Corners of inserts may not touch.*

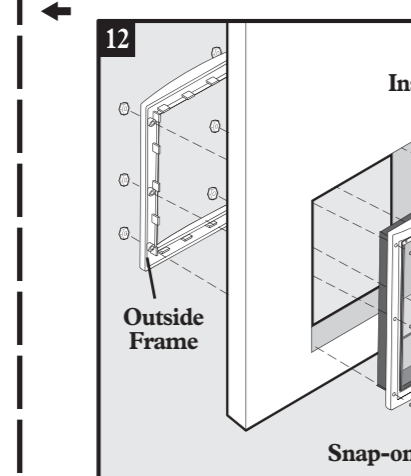

12

- Fit outside frame into cut-out opening.
- Place inside frame in cut-out opening.
- Thread plastic screws through holes in frame. Secure with hex nuts (Do not overtighten).
- Cut off excess screw with wire cutters.
- Caulking is optional around frame.

Note: If you have a raised panel door, after you have cut your opening, build up the low area with wood strips to make your surface even and support the frame.

Product Warranty

To get the most protection out of your limited warranty, please register your product within 90 days at www.petSAFE.net. By registering, you will enjoy the product's full warranty and should you ever need to call the Customer Care Center at 1-800-732-2677 (US), 1-800-457-3911 (Canada), we will be able to help you faster. Additionally, you will not have to save your product receipt as registering serves as proof of purchase. Most importantly, PetSafe® will never give or sell your valuable information to anyone.

Keep for your records
PetSafe® Plastic Pet Door Small
Pet Requirement
PACT1-1037

Keep for your records
PetSafe® Plastic Pet Door Medium
Pet Requirement
PACT1-1038

Keep for your records
PetSafe® Plastic Pet Door Large
Pet Requirement
PACT1-1039

Keep for your records
PetSafe® Plastic Pet Door Extra Large
Pet Requirement
PACT1-1040

Center Line



Plastic Pet Door

Manuel d'installation et modèle

Guía de instalación y plantilla

Outils requis / Se necesitan las siguientes herramientas

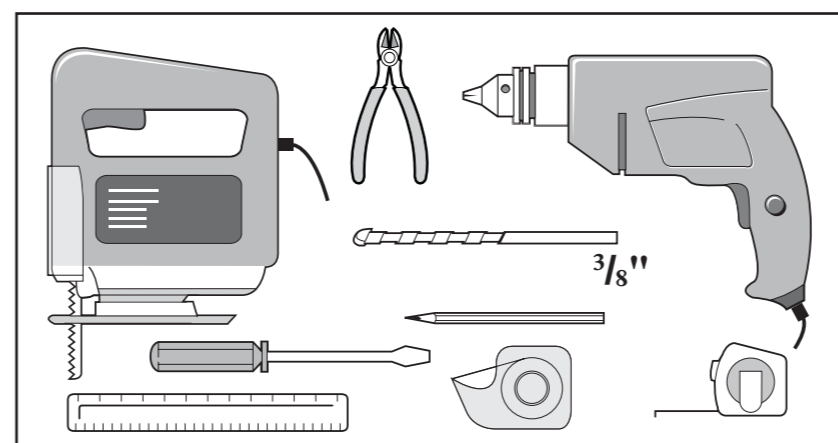

Contenu / Contiene

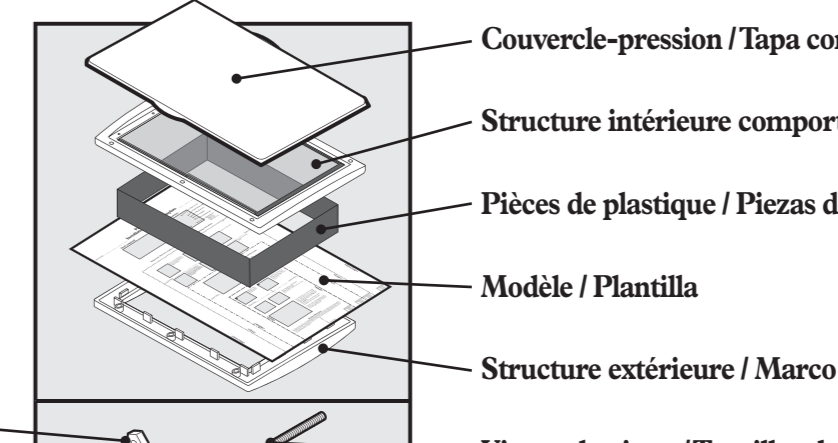

Écrous hexagonaux
Tuerces hexagonales
-Petits / Pequeño: 4 pcs.
-Moyens / Mediano: 6 pcs.
-Grands / Grande: 10 pcs.
-Très grands / Extragrande: 12 pcs.

Vis en plastique / Tornillos de plástico
-Petits / Pequeño: 4 pcs.
-Moyens / Mediano: 6 pcs.
-Grands / Grande: 10 pcs.
-Très grands / Extragrande: 12 pcs.

Important: pour des résultats optimaux, appliquer une couche d'apprêt sur le plastique avant d'appliquer la peinture.
Importante: Para mejores resultados, antes de pintar, aplique una base de imprimación para plástico.

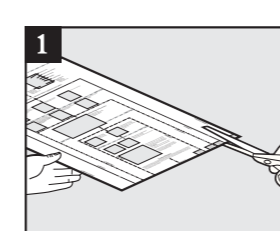

1 Découper le modèle à la taille appropriée.
Remarque: si vous avez acheté une couverture en plastique de très grande taille, aucun découpage n'est nécessaire.
Corte la plantilla del tamaño apropiado.
Nota: Si ha comprado una puerta para mascotas de plástico de tamaño extragrande, no es necesario hacer cortes.

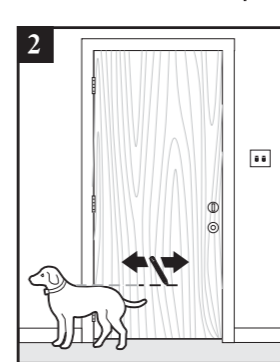

2 Mesurer la hauteur de l'animal au niveau de l'épaule et la reporter sur la porte. Méta y marque en la puerta la altura de su mascota.



3 *Optionnel* Retirer la porte (Facultatif)
Retire la puerta (Opcional).

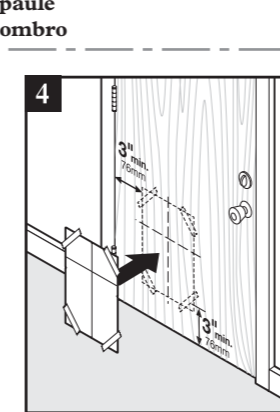

4 Faire correspondre la ligne de la hauteur au niveau de l'épaule de la porte à celle indiquée sur le modèle. Dessiner une ligne autour du modèle. Retirer le modèle. **Important:** la distance entre l'ouverture et le bas de la porte ne doit pas dépasser 3 po, de même que la distance entre l'ouverture et le côté de la porte équipé de charnières.

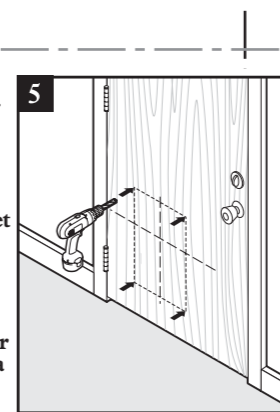

5 Percer des trous de 1/8 po dans les coins (sauter pour la lame de la scie). Perfore orificios de 1/8" en las esquinas (orificios piloto para la hoja de la sierra).

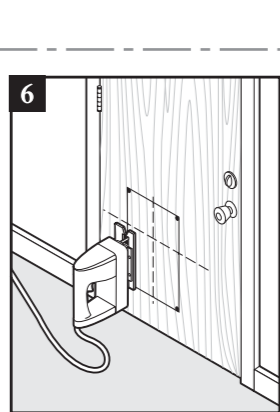

6 Couper entre les trous à l'aide d'une scie sauteuse. Con una sierra de vaivén, corte entre los orificios.

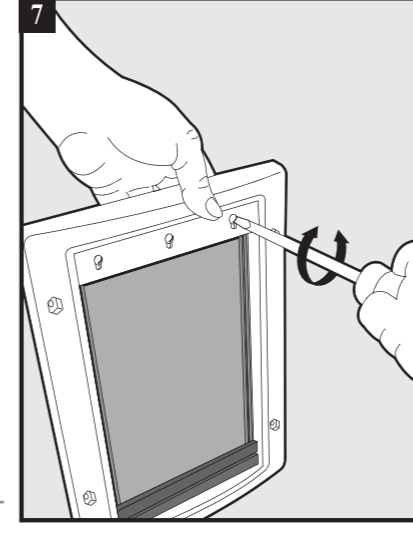

Ajuster les volets au besoin

- Desserrer les vis
- Tirer le volet vers le haut pour l'ajuster
- Resserrer les vis

Si es necesario, ajuste los postigos

- Alíjelo los tornillos
- Tire hacia arriba para ajustar el postigo
- Apriete los tornillos

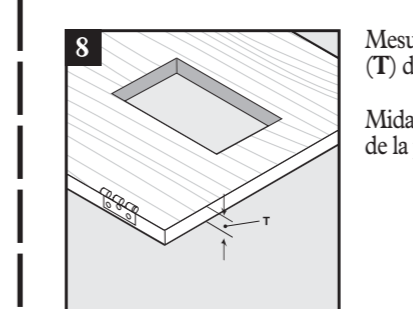

8 Mesurer l'épaisseur (T) de votre porte.

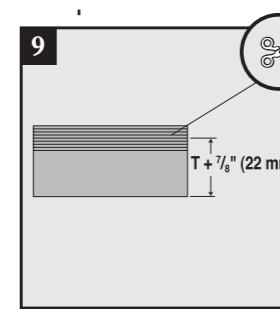

9 Découper le côté rainuré des pièces de plastique afin d'arriver à une épaisseur équivalente à celle de votre porte (T), plus 1/8 po. Corte el lado de las piezas de inserción de plástico que tiene la ranura al mismo grosor (T) de la puerta + 1/8".

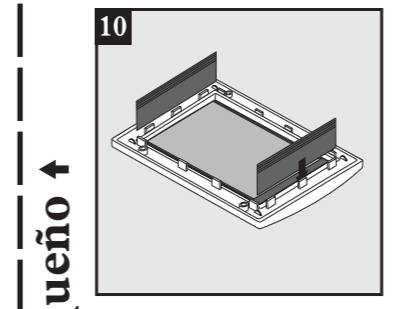

10 Insérer les pièces dans la structure intérieure (celle qui comporte un volet).



11 Colocque le marco exterior en la abertura cortada. Enroscate los tornillos plásticos en los orificios del marco. Fijalos con tuercas hexagonales (no las apriete demasiado).

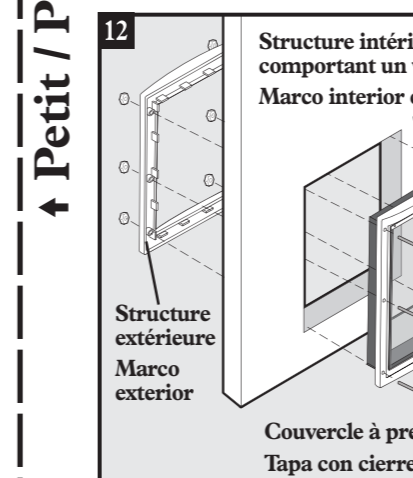

12 Structure intérieure / Marco interior con postigo



12 Structure extérieure / Marco exterior

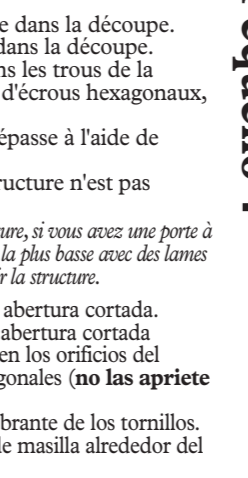

12 Couverture à pression / Tapa con cierre a presión

Garantie du produit / Garantía del producto

Pour optimiser la protection de votre garantie limitée, veuillez enregistrer votre produit dans un délai de 90 jours sur le site www.petSAFE.net. En enregistrant votre produit, vous pourrez profiter d'une garantie complète et le centre de service à la clientèle 1-800-732-2677 (US), 1-800-457-3911 (Canada) pourra vous répondre plus rapidement, si vous avez besoin d'assistance. De plus, vous n'avez pas besoin de conserver votre reçu car l'enregistrement en ligne sert de preuve d'achat. Plus important encore, PetSafe® ne divulguera et ne vendra aucun renseignement personnel à qui ce soit.

Para obtener la mayor protección de su garantía limitada, registre su producto durante el plazo de 90 días en www.petSAFE.net. Al registrarse, usted disfrutará de la garantía completa del producto y en caso de que necesite llamar al Centro de atención al cliente 1-800-732-2677 (US), 1-800-457-3911 (Canada), podremos ayudarlo de manera más rápida. Además, no tendrá que conservar el recibo de su producto ya que el registro sirve como comprobante de la compra. Lo más importante, PetSafe® nunca entregará ni venderá su valiosa información a terceros.

À conserver dans vos dossiers
To keep in your records
PetSafe® Plastic Pet Door Small
Pet Requirement
PACT1-1037

À conserver dans vos dossiers
To keep in your records
PetSafe® Plastic Pet Door Medium
Pet Requirement
PACT1-1038

À conserver dans vos dossiers
To keep in your records
PetSafe® Plastic Pet Door Large
Pet Requirement
PACT1-1039

À conserver dans vos dossiers
To keep in your records
PetSafe® Plastic Pet Door Extra Large
Pet Requirement
PACT1-1040

Ligne centrée / Línea Central 408-032-1111

Radio Systems Corporation
10427 Electric Avenue
Knoxville, TN 37932
1-800-732-2677 (US), 1-800-457-3911 (Canada)
©2008, Radio Systems Corporation