

HEAVY DUTY AIR HAMMER

with 5 Chisels

Stock Number M668

OWNER'S MANUAL



FOR YOUR SAFETY,
please read these instructions carefully and retain them for future use.

**Performance
Tool**

SPECIFICATIONS

Bore Size (IN)	3/4
Stroke Length (IN)	2.6
Air Pressure (PSI).....	90
Average Air Consumption (CFM)	4.8
Free Speed (BPM).....	3,500
Air Inlet (NPT).....	1/4 in.
Hose Size (ID).....	3/8 in.
Length (IN).....	6.6
Weight (LBS)	3.1

Specifications are subject to change without notice

IMPORTANT SAFETY INFORMATION

WARNING!

READ, UNDERSTAND AND FOLLOW ALL INSTRUCTIONS AND WARNINGS BEFORE OPERATING THIS TOOL. FAILURE TO DO SO MAY RESULT IN PERSONAL INJURY AND/OR PROPERTY DAMAGE AND WILL VOID WARRANTY.

Warning!

Oil tool before each use. 4 to 5 drops of a good grade Air Tool Oil placed in the air inlet is sufficient. Use proper air pressure and CFM rating listed for this tool.

1. Keep work area clean. Cluttered areas invite injuries.
2. Observe work area conditions. Do not use machines or power tools in damp or wet locations. Don't expose to rain. Keep work area well lighted. Do not use electrically powered tools in the presence of flammable gases or liquids. Do not bring combustible materials near the tools.
3. Keep children away. Children must never be allowed in the work area. Do not let them handle machines, tools, hoses or extension cords.
4. Store idle equipment. When not in use, tools must be stored in a dry location to inhibit rust. Always lock up tools and keep out of reach of children and other untrained persons. Switch off all unused electrical tools when stored. Tools are dangerous in the hands of untrained users.
5. Always wear approved eye protection when using tools. If raising dust, wear a suitable mask. Any spectators in the area will need eye and ear protection as well.
6. Work Safe. When wearing gloves to operate the Air Hammer, make sure that the gloves do not interfere with operating the Trigger (11). Test your gloves with the Trigger (11) before attaching the unit to an air source. Keep your finger away from the Trigger (11) until you are ready to work.

IMPORTANT SAFETY INFORMATION

7. Never start the tool unless you have a firm grip with both hands and you are positioned at your workpiece or area.
8. Before using the Air Hammer, know what is directly underneath the work area or workpiece. The Air Hammer can quickly penetrate material. If working directly on the ground, make sure you are not directly above shallow cables, lines, or pipes. Do not wear loose clothing or jewelry that could become caught by moving parts, causing injury.
9. Keep your limbs and body clear of the tool. Beware of flying chips of wood, concrete, metal, or any other material being hammered. If a chisel or bit breaks off, the tool tends to surge forward suddenly. Operate tool a safe distance from yourself and others in the work area. Make sure the immediate area is clear of other people or animals. Spectators must stay at a safe distance.
10. Never point the tool or the air hose (not included) at anyone. Keep proper footing and balance at all times. Do not reach over or across running machines, hoses, etc.
11. Do not operate any tool if under the influence of alcohol or drugs. Read warning labels on prescriptions to determine if your judgment or reflexes are impaired while taking drugs. If there is any doubt, do not operate any tool.
12. Be sure air is in OFF position when connecting tool to air supply.
13. Use only those accessories that are designed for use with tools. For example, with impact wrenches do not use ordinary sockets. Use impact sockets for all air tools.
14. Be sure to disconnect tool from air supply before changing accessories, performing service on tool and when not in use.
15. Follow air source manufacturers' directions for connection of regulators, filters, and other accessories to air source. Do not install quick couplers directly on tool as they put unnecessary strain on the air inlet threads possibly causing them to wear out prematurely. Instead, install them on a short length of air hose attached to the tool.
16. Check for damaged parts. Before using any tool, any part that appears damaged should be carefully checked to determine that it will operate properly and perform its intended function. Check for alignment and binding of moving parts; any broken parts or mounting fixtures; and any other condition that may affect proper operation. Any part that is damaged should be properly repaired or replaced by a qualified technician.
17. Maintenance. For your safety, maintenance should be performed regularly by a qualified technician using original PERFORMANCE TOOLS® replacement parts. Failure to do so can lead to accidents for the operator. Use of any other parts will void the warranty. Only use accessories intended for use with this tool. Approved accessories are available from Performance Tool®. Use only accessories that are recommended by the manufacturer for your model. Accessories that may be suitable for one tool may become hazardous when used on another tool.

WARNING: Repetitive motions or exposure to vibration may be harmful to your hands and arms.

WARNING: This product and its packaging contain a chemical known to the State of California to cause cancer, birth defects, or other reproductive harm.

WARNING: The warnings, cautions, and instructions discussed in this instruction manual cannot cover all possible conditions and situations that may occur. It must be understood by the operator that common sense and caution are factors which cannot be built into this product, but must be supplied by the operator. Read and understand all of the instructions provided in the instruction manual of this product, as well as, any other tool (s) used with this product.

ASSEMBLY / INSTALLATION

1. You will need to prepare the 1/4 in. Quick-disconnect Coupler Plug to connect to the air inlet on the Air Hammer. Wrap the Coupler Plug with pipe thread seal tape before threading it into the Air Inlet (9). Connect the a Quick-Disconnect coupler on a 3/8 in. ID Air Source Hose to the tool.

Note: If you are not using an automatic oiler system, before operation, add a few drops of Pneumatic Tool Oil to the airline connection. Add a few drops more after each hour of continual use.

2. Set the air pressure on your compressor to 90 PSI. Do not exceed the recommended air pressure of 90 PSI.
3. Check the air connection for leaks. Once you are satisfied there are no leaks, turn off the air compressor and disconnect the tool.

OPERATION

WARNING: Always disconnect the tool from the air source before examining or changing bits.

1. Select the appropriate chisel/bit. Unscrew the Retainer Spring (18) and insert the shank of the chisel/bit. Screw the Retainer Spring (18) back onto the Cylinder (17). Holding the Air Chisel firmly, pull the chisel/bit hard to make sure it locked into place.

Note: Before connecting the air supply, make sure you are wearing safety goggles and a full face mask, ear protection, and steel toe shoes.

Warning: Any spectators in the immediate area will need eye and ear protection. Beware of flying chips of wood, concrete, metal, or any other material being chiseled.

2. Connect the air hose to the Air Inlet (8) and turn on the compressor (not included).
3. Grip the Air Hammer with both hands firmly and put the chisel/bit tip up against the workpiece you wish to chip.
4. Gently squeeze the Trigger (11) and move slowly along the workpiece. Do not push down on the Air Hammer; let it do the work. If it does not do the intended job to satisfaction, examine your bit to see if it is worn or dull.

Warning!: Always disconnect from the air source before examining or changing bits.

5. When you are finished, turn off the air supply and then hold the Air Hammer in a safe direction and Squeeze the trigger to bleed off the remaining air. Then, disconnect the air hose.

AIR SOURCE

Clean air of correct air pressure is recommended for the power supply for this tool. A maximum of 90 PSI at the tool is recommended for most air tools of this class. Check specifications section for recommended pressure. (Depending on length of air hose and other circumstances, air pressure at compressor may need to be increased to 100 PSI to ensure 90 PSI at the tool.)

Water in the air hose and compressor tank contributes to reduced performance and damage of the air tool. Drain the air tank and filters before each use and as necessary to keep the air supply dry.

Hose length over 25' causes loss in line pressure. Increase hose I.D. or increase compressor pressure to compensate for the pressure loss. Use an in-line pressure regulator with gauge if air inlet pressure is critical.

LUBRICATION & MAINTENANCE

Warning: Always disconnect from the air source before attempting maintenance.

1. After each use, wipe the Air Hammer down with a lint free cloth.
2. Make sure there are no concrete chips, dirt, or debris in the Retainer Spring (15).
3. Before storage, add a small quantity of high quality pneumatic oil in the Air Inlet (8).
4. Examine your chisels/bits before using them. If a chisel is dull or cracked do not use it. Replace worn or broken chisels with approved replacement chisels from Performance Tool®.

Oil tool before each use. 4 to 5 drops of a good grade Air Tool Oil placed in the air inlet is sufficient. Use proper air pressure and CFM rating listed for this tool.

Drain water from hoses and compressor tank. Water in the air supply line will cause gumming and loss of power. Clean the air filter on the supply line and flush the tool with gum solvent or a 50/50 mix of air tool oil and kerosene. It may be necessary to disassemble the tool to properly clean and re-lubricate.

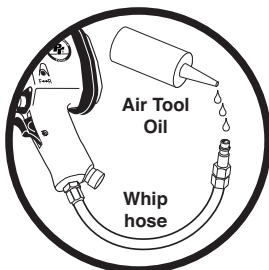

Yes



No

REPLACEMENT PARTS LIST

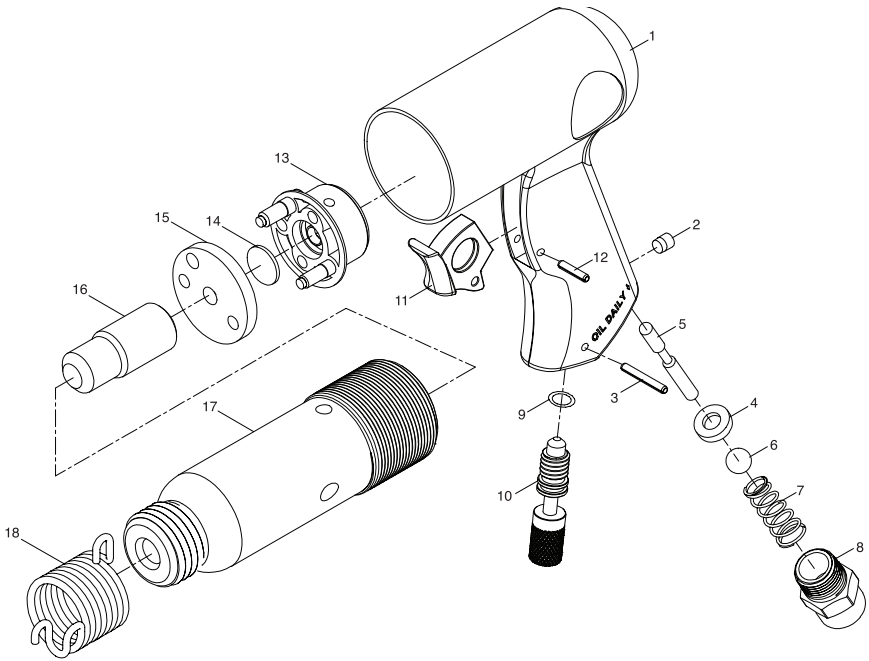

#	Part #	Description	Quantity
1		Housing	1
2		Plug	1
3		Pin	1
4	M668K-01	O-Ring	1
5		Valve Stem	1
6		Steel Ball	1
7		Spring	1
8		Air Inlet	1
9	M668K-01	O-Ring	1
10	M668K-01	Air Regulator	1
11		Trigger	1
12		Trigger Pin	1
13	M668K-01	Valve Case	1
14	M668K-01	Valve Pad	1
15	M668K-01	Front Valve Seat	1
16		Piston	1
17		Cylinder	1
18	M696	Spring	1

TROUBLESHOOTING

INSUFFICIENT POWER:

Probable Cause	Solution
Dirty or clogged air passages.....	Flush and lubricate tool, drain air tank and supply line
Insufficient air supply.....	Increase line pressure, Make sure compressor matches tool's air pressure and consumption needs
Air leakage.....	Use PTFE tape at all fittings and joints. Check tool for worn or damaged O-rings & seals.
Worn/damaged wear & tear parts...	Replace as necessary.
Tool matching	Be sure you are using a tool suited for the torque requirements of the job at hand.

LIMITED WARRANTY

PERFORMANCE TOOL® extends only the following warranties, and only to original retail purchasers. These warranties give specific legal rights. Except where prohibited by local law, the law of the State of Washington governs all warranties and all exclusions and limitations of warranties and remedies. There may be other rights which vary from state to state.

PERFORMANCE TOOL® warrants the product to be free from defects in materials and workmanship under normal use and service. A defective product may be returned for a free replacement within 90 days from the date of purchase, provided that product is returned to place of purchase immediately after discovery of defect. After 90 days and up to one year from date of purchase, PERFORMANCE TOOL® will replace at no charge any parts which our examination shall disclose to be defective and under warranty. These warranties shall be valid only when a sales receipt showing the date of purchase accompanies the defective product or defective part (s) being returned. For part (s) after 90 days, please remit your request, postage prepaid to:

PERFORMANCE TOOL, P.O. Box 88259 Tukwila, WA 98138

These warranties exclude blades, bits, punches, dies, bulbs, fuses, hoses, and other consumables which must be replaced under normal use and service. These warranties shall not apply to any product or part which is used for a purpose for which it is not designed, or which has been repaired or altered in any way so as to affect adversely its performance or reliability, nor shall these warranties apply to any product or part which has been subject to misuse, neglect, accident or wear and tear incident to normal use and service.

PERFORMANCE TOOL® does not authorize any other person to make any warranty or to assume any liability in connection with its products.

Except for warranties of title and the limited express warranties set forth above, PERFORMANCE TOOL® makes no express or implied warranties of any kind with respect to its products. In particular, PERFORMANCE TOOL® makes no implied warranty of merchantability and no implied warranty of fitness for any particular purpose, except that for goods purchased primarily for personal, family or household use and not for commercial or business use, PERFORMANCE TOOL® makes an implied warranty of merchantability (and, if otherwise applicable, an implied warranty of fitness for a particular purpose), but only for the particular qualities or characteristics, and for the duration, expressly warranted above.

The laws on limitation of implied warranties may differ from state to state, so the above limitations may not apply in all cases.

PERFORMANCE TOOL® shall not be liable for consequential, incidental or special damages resulting from or in any manner related to any product, or to the design, use, or any inability to use the product. The sole and exclusive remedy for a defective product or part shall be the repair, or replacement thereof as provided above. The laws on limitation of remedies or on consequential, incidental or special damages may vary from state to state, so the above limitations may not apply in all cases.