

# Service Manual

Ventilating Fan  
(North America Market)

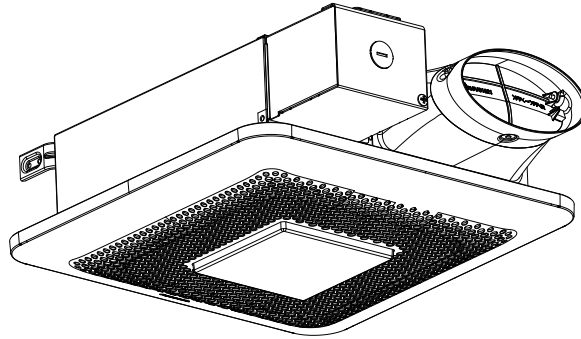

RG-T810LHA

## ⚠ WARNING

This service information is designed for experienced repair technicians only and is not designed for use by the general public. It does not contain warnings or cautions to advise non-technical individuals of potential dangers in attempting to service a product. Products powered by electricity should be serviced or repaired only by experienced professional technicians. Any attempt to service or repair the product or products dealt with in this service information by anyone else could result in serious injury or death.

## IMPORTANT SAFETY NOTICE

There are special components used in this equipment which are important for safety. These parts are marked by ⚠ in the Schematic Diagrams, Exploded Views and Replacement Parts List. It is essential that these critical parts should be replaced with manufacturer's specified parts to prevent shock, fire or other hazards. Do not modify the original design without permission of manufacture.  
We suggest to handle such parts after the static electricity prevention.  
It is forbidden to touch the PCB parts by bare hands during the repairing process.

CONTENTS	PAGE
1.Specifications-----	1
2.Parts Identification-----	2~4
3.Wiring Diagram-----	5
4.Parts List-----	6, 7

# 1. Specifications

---

Model No.	Air direction	Voltage (V)	Frequency (Hz)	Duct diameter (inches)	Air volume (CFM)	Noise (sones)	Speed (rpm)	Power (W)	Weight lb. (kg)
RG-T810LHA	Exhaust	120	60	4	80	0.5	881	8.9	7.9 (3.6)
					100	1.1	993	13.2	

HVI Certified performance based on HVI Procedures 915, 916, and 920, at 0.1” WG.

# 2. Parts Identification

RG-T810LHA

## Main Body Section

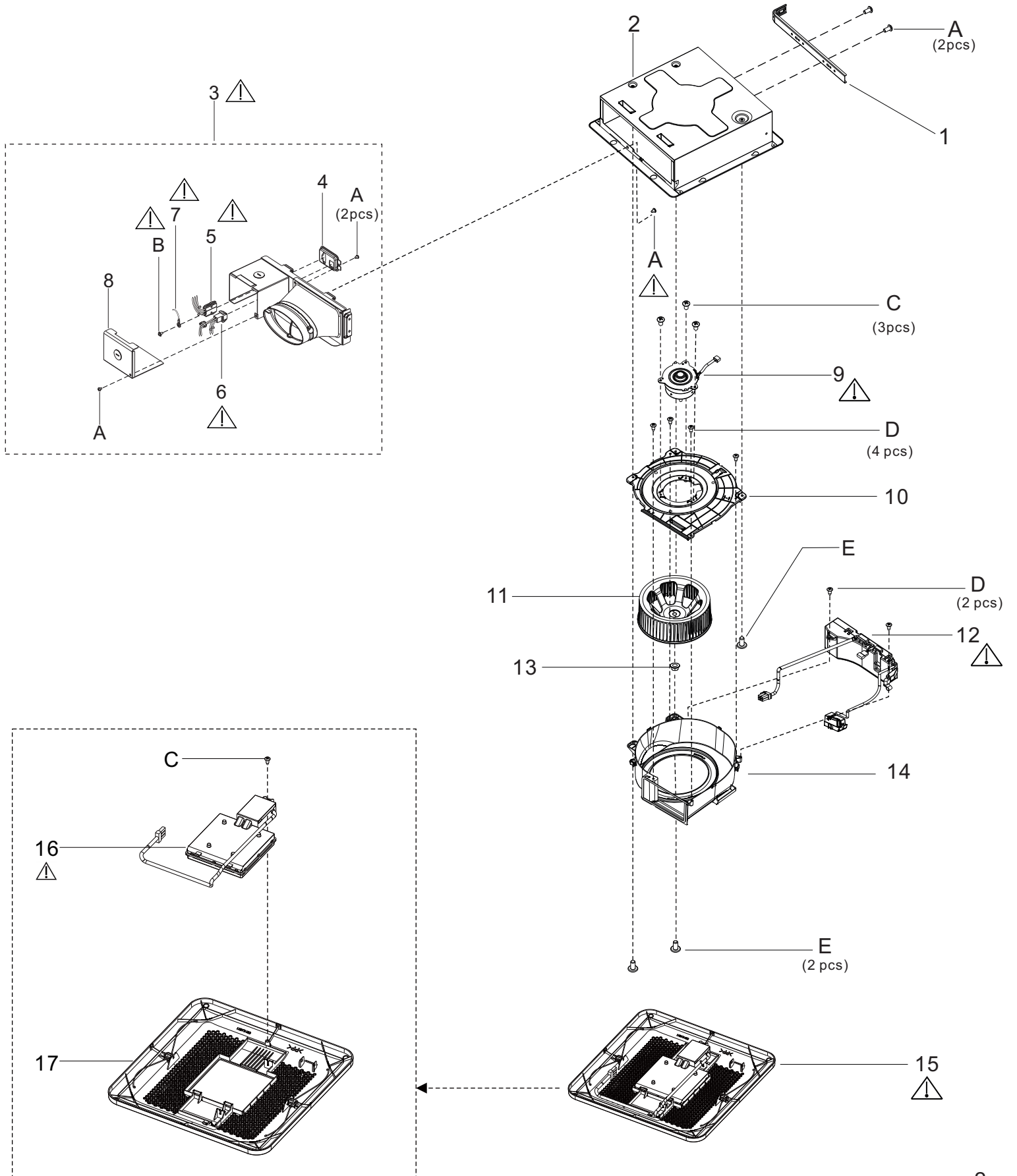

# 2. Parts Identification

RG-T810LHA

## Main PCB Section

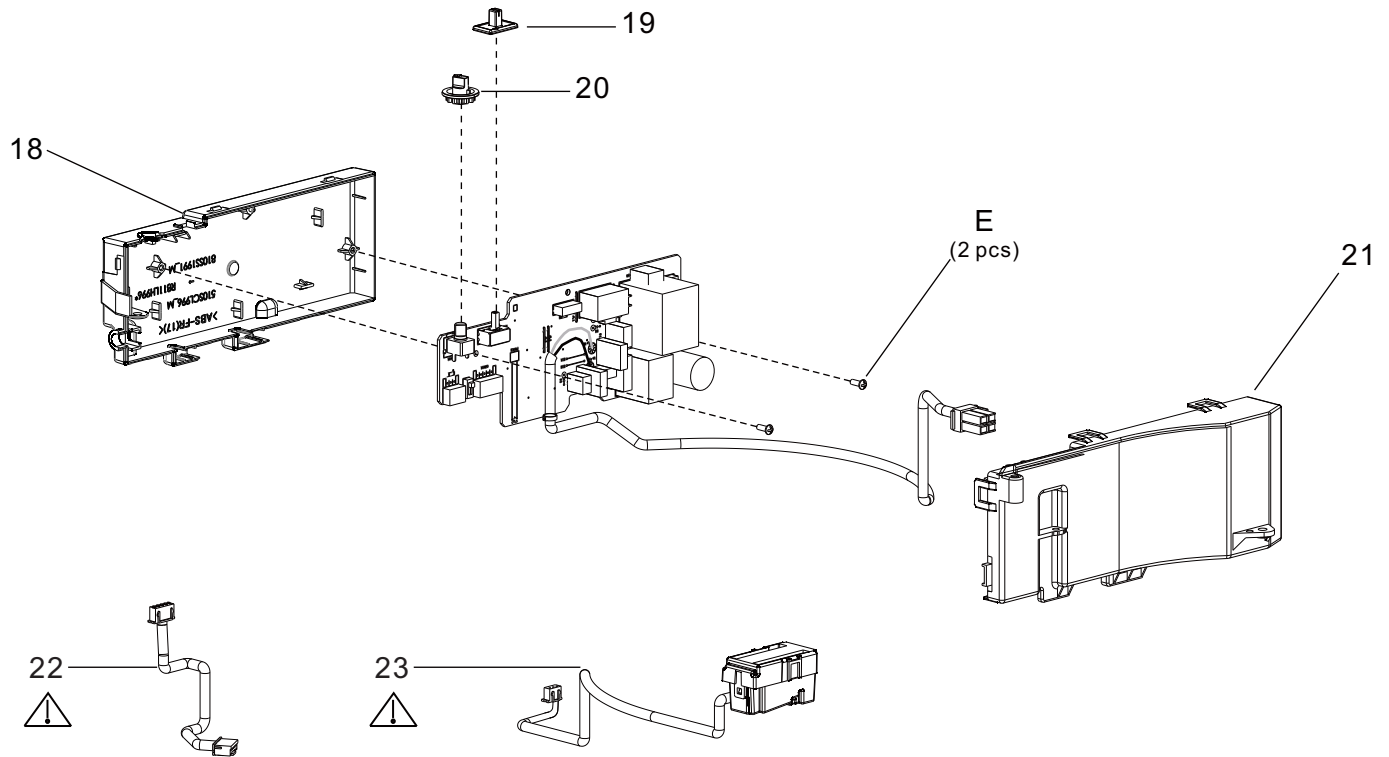

## Main Labels

**Panasonic** Ventilating Fan

Model No. RG-T810LHA **FC M**

AC 120 V 60 Hz  
0.39 A (Fan) 0.1 A (Light)

	CFM	Sones	CFM	Sones
0.1" SP	100	1.1	80	0.5

Panasonic Corporation of North America  
Assembled in Mexico

24

**ATTENTION**

Circuit board assembly inside, do not drill the can/housing. For details, please refer to installation instructions.

**ATTENTION**

Carte de circuit imprimé à l'intérieur, ne percez pas le boîtier. Pour plus de détails, consultez les instructions d'installation.

25

%RH

CFM

30 40 50 60 70 80

80 100

26

TESTED/CERTIFIED  
2100  
Home Ventilating Institute

ENERGY STAR

Not for use in cooking area-See installation instructions./Non destiné à la zone de cuisson-Voir instructions d'installation./No usar en áreas donde se cocina-Consulte las instrucciones de instalación.

27

E78414

LISTED FAN

28

# 2. Parts Identification

RG-T810LHA

## Packing Section

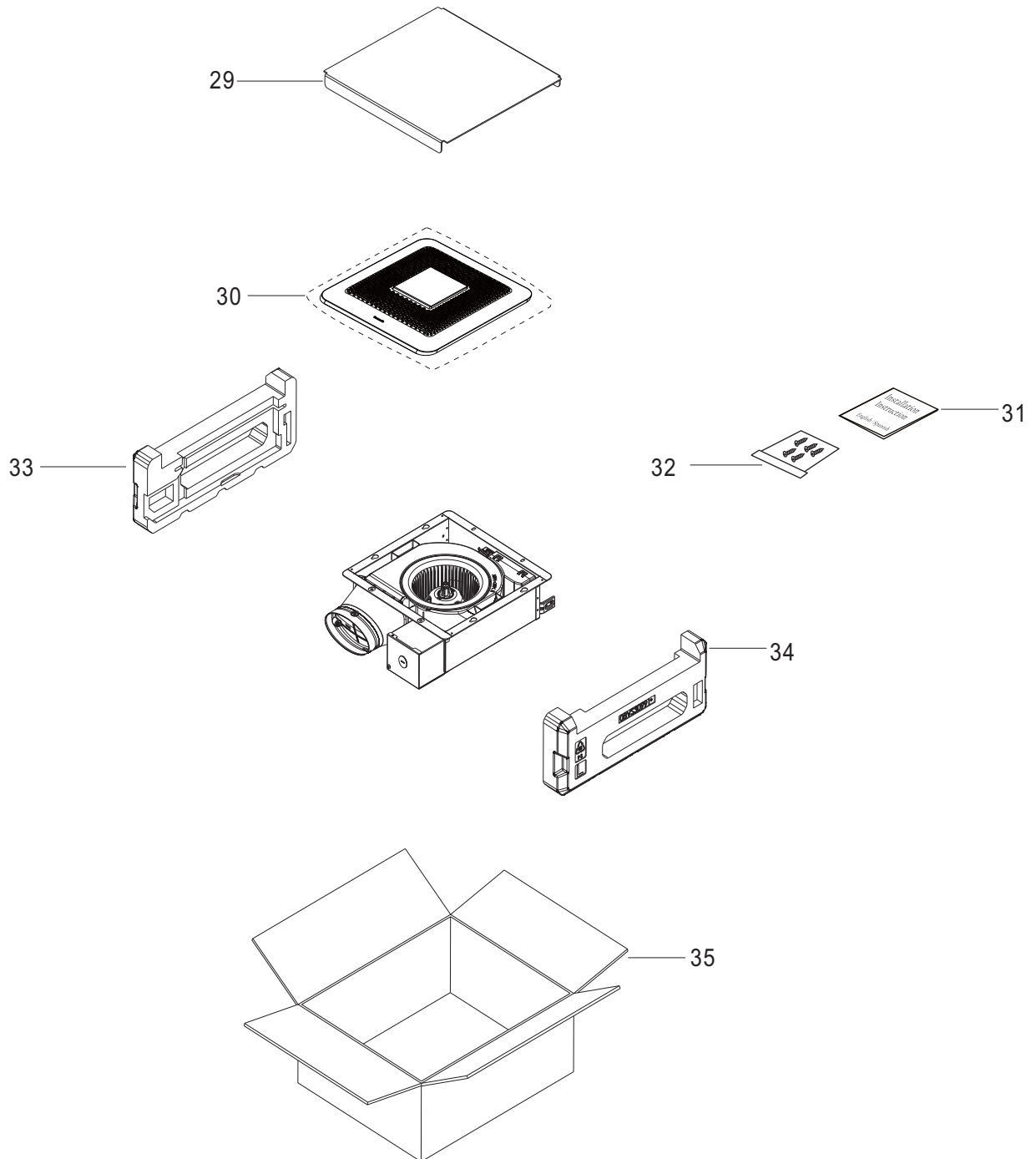

# 3. Wiring Diagram

RG-T810LHA

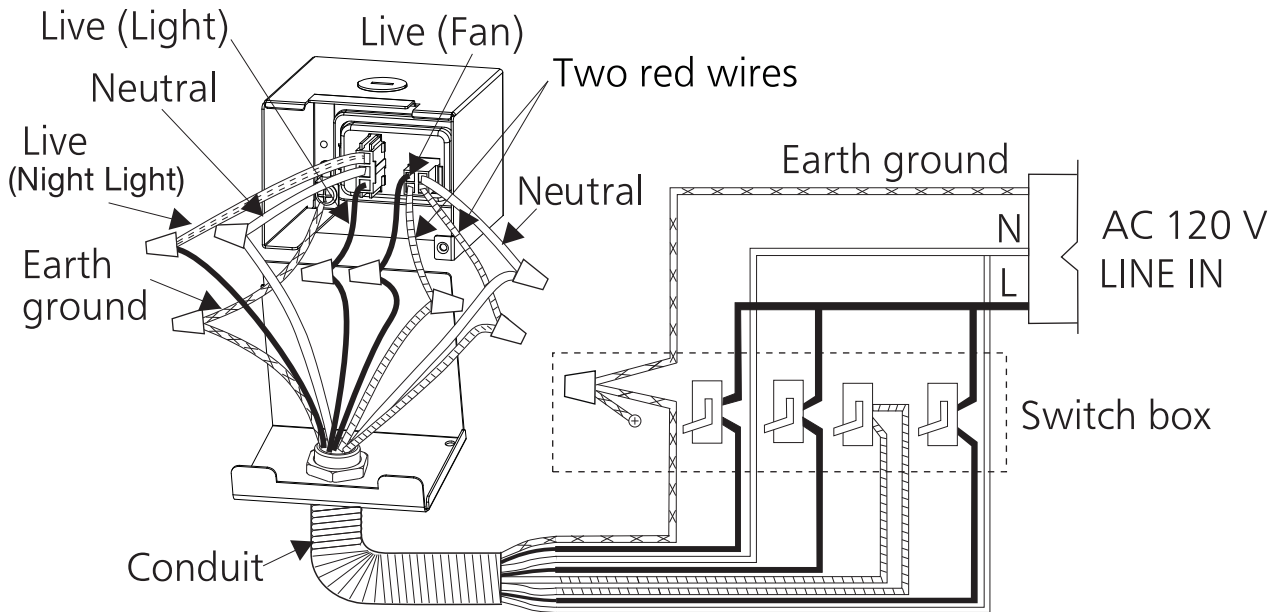
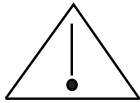
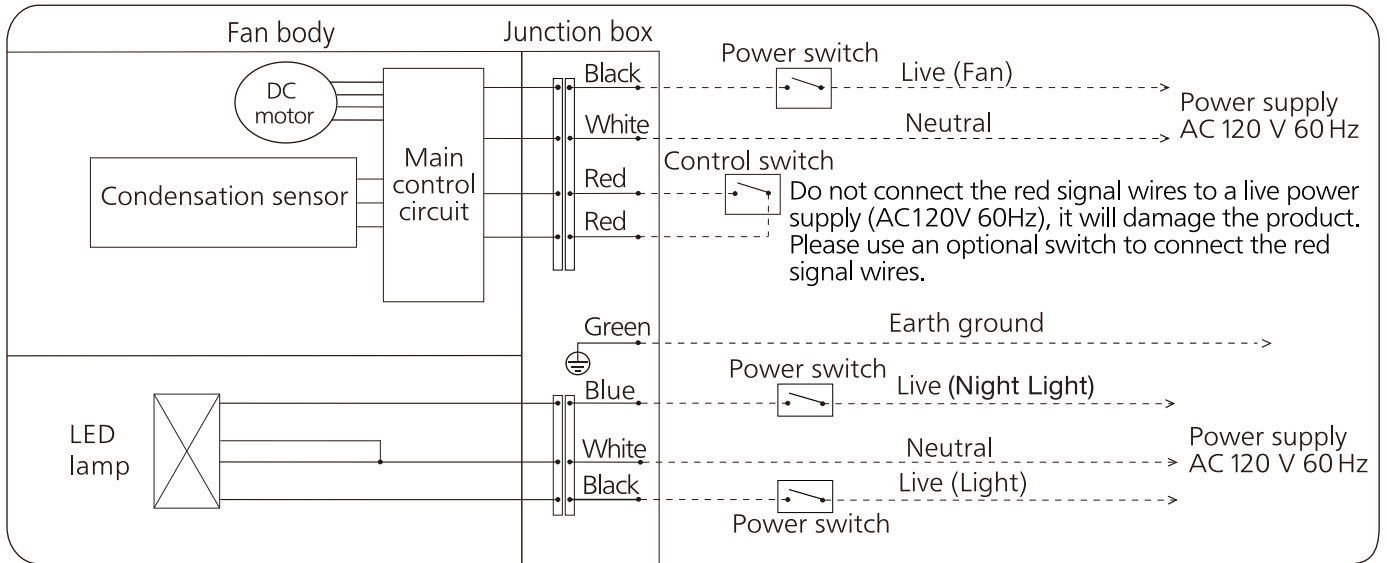
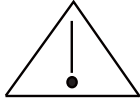







- White      ▨ Red      ▤ Blue      ◁ Wire nuts
- Black      ▩ Green      ⌋ Switch



# 4. Parts List

RG-T810HA

## Main Body Section

No.	Part No.	Part Name	Q'ty	Remark
1	FFV5710025S	Suspension Bracket	1	
2	FFV1600159S	Frame Assy	1	
3	FFV0000172S	Adapter Assy	1	
4	FFV0900054S	Connector Plate	1	
5	FFV0900069S	Connector Assy (L)	1	
6	FFV0900073S	Connector Assy(V)	1	
7	FFV3450010S	Earth Lead Wire	1	
8	FFV2800020S	Junction Cover	1	
8	FFV10VS1M2	Motor Assy	1	
10	FFV510VS19	Motor Support	1	
11	FFV510VS18	Blade	1	
12	FFVT810LHA	Main PCB Assy	1	
13	FFV7020021S	Nut	1	
14	FFV510VS10	Casing	1	
15	FFVC811LH810	Grill Assembly	1	
16	FFV11QCL1070	Led Unit	1	
17	FFVC811LH811	Grill Section	1	
A	FFV7000108S	Truss Tap Screw	5	
B	FFV7000227S	Earth Screw Assy	1	
C	FFVXTT48GFJ	Bind Tap Screw	4	
D	FFVXTT412GFJ	Bind Tap Screw	6	
E	FFV7000202S	Bind Tap Screw	3	

## Main PCB Section

No.	Part No.	Part Name	Q'ty	Remark
18	FFV811LH996	Main PCB Box	1	
19	FFV510VS1M9	Speed Switch	1	
20	FFV510SCL99	Rotation Switch	1	
21	FFV510SCL97	Main PCB Cover	1	
22	FFV510VS112	Motor Lead Wire	1	
23	FFV510SCL12	Humidity Sensor	1	
F	FFVXTN268GFJ	Screw	1	

## 4. Parts List

RG-T810HA

### Main Labels

No.	Part No.	Part Name	Q'ty	Remark
24	FFVT810LH15	Name Plate	1	
25	FFV6730110S	Warning Label	1	
26	FFV810LH154	Label Indication	1	
27	FFV0810011S	Caution Label 1	1	
28	FFV2260003S	UL Mark	1	

### Packing Section

No.	Part No.	Part Name	Q'ty	Remark
29	FFV4710381S	Louver Case Assy	1	
30	FFV4650016S	Poly Cover	1	
31	FFVT810LH42	Installation Instructions (ES)	1	
32	FFV0010231S	Accessory A	1	
33	FFV4710369S	Right Pad	1	
34	FFV4710370S	Left Pad	1	
35	FFVT810LH40	Packing Case Assy	1	