

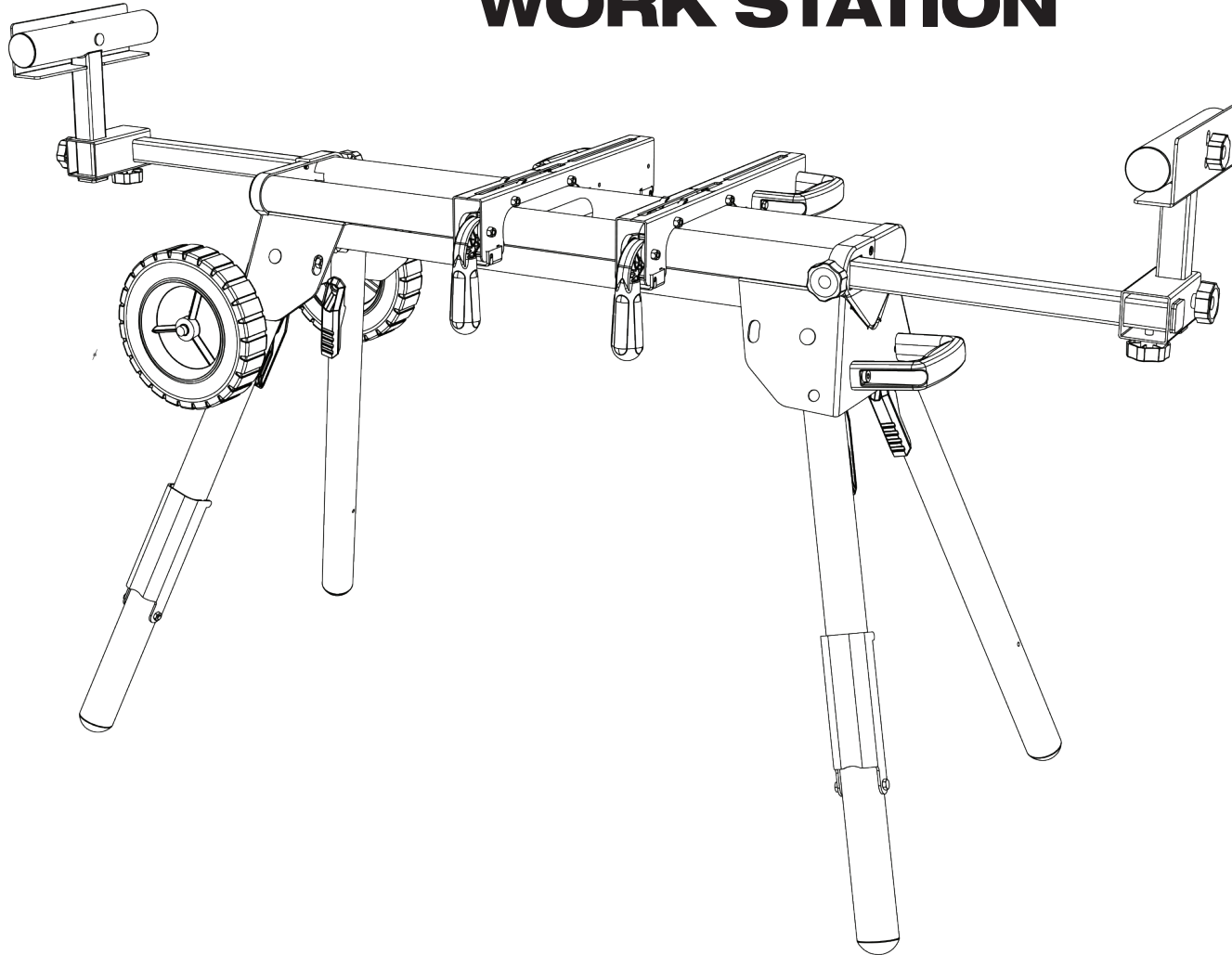

PROTOCOL™

PRODUCT MANUAL CONTRACTOR MITER SAW WORK STATION



OVERVIEW

You have just purchased a Contractor Work Station. This product has been specifically designed to assist you in the use of your 10-12" miter saw, as well as increasing efficiency with other bench top tools such as table saws, band saws, planers, etc.

SAFETY WARNING

WARNING: Be sure to read and understand all safety instructions in this manual, including all safety alert symbols such as “DANGER”, “WARNING” and “CAUTION”, before using this power tool accessory. Failure to follow all instructions listed in the manual may result in electric shock, fire and/or serious personal injury.

GENERAL SAFETY INSTRUCTIONS FOR POWER TOOLS

Using power tools of any kind can be dangerous if safe operation procedures are not followed. Recognizing the hazards of each tool and using them with respect and caution will considerably limit the possibility of personal injury. However, if safety precautions are ignored, personal injury will likely result. Always use common sense – your personal safety is your responsibility.

1. Know your power tool. Read and understand the Product Manual and observe the warnings and instruction labels affixed to the tool.
2. Properly ground all tools.
3. Keep guards in place.
4. Remove adjusting keys and wrenches.
5. Keep work area clean and dry.
6. Keep children away.
7. Never leave running machines/tools unattended.
8. Disconnect tools from service.
9. Use correct tools for the job.
10. Never force a tool.
11. Wear safety apparel.
12. Wear safety glasses/goggles.

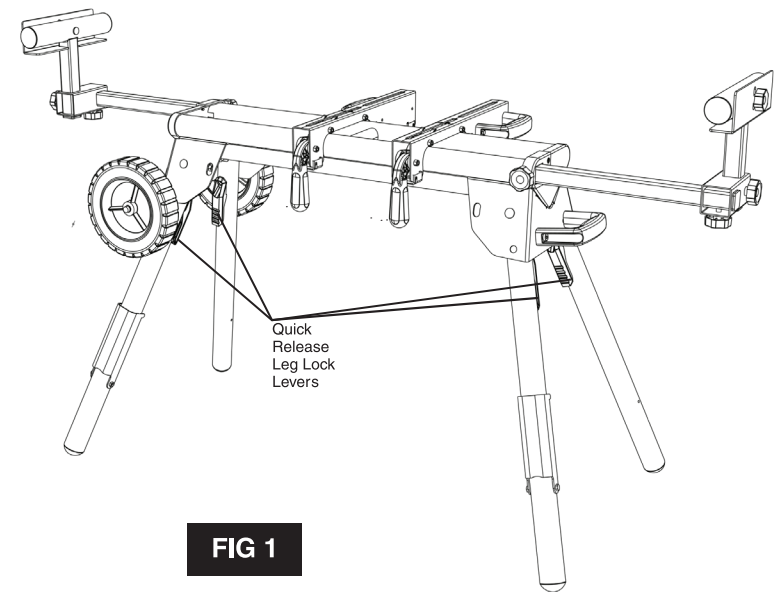

FIG 1

13. Never stand or sit on tools.
14. Replace damaged components immediately.
15. Make sure your work platform is sufficiently sturdy to do the specific job at hand.
16. Properly anchor blade for job being done.
17. Use correct blade for job being done.
18. Think safety. Safety is a combination of operator awareness, common sense and alertness at all times.

SAFETY INSTRUCTIONS FOR MITER SAW STANDS

1. Use caution when folding or unfolding legs to limit any finger pinch points.
2. Place stand on flat and level surface to keep from rocking or tipping.
3. Make sure that work support extensions (if included) are within safe operating limits, and are properly locked in place before using tool. Do not exceed the rated capacity on main frame table.
4. Test the setup for stability before proceeding with work.
5. Be sure the miter saw is tightened securely at all mountings before use for folding the work station for transport.

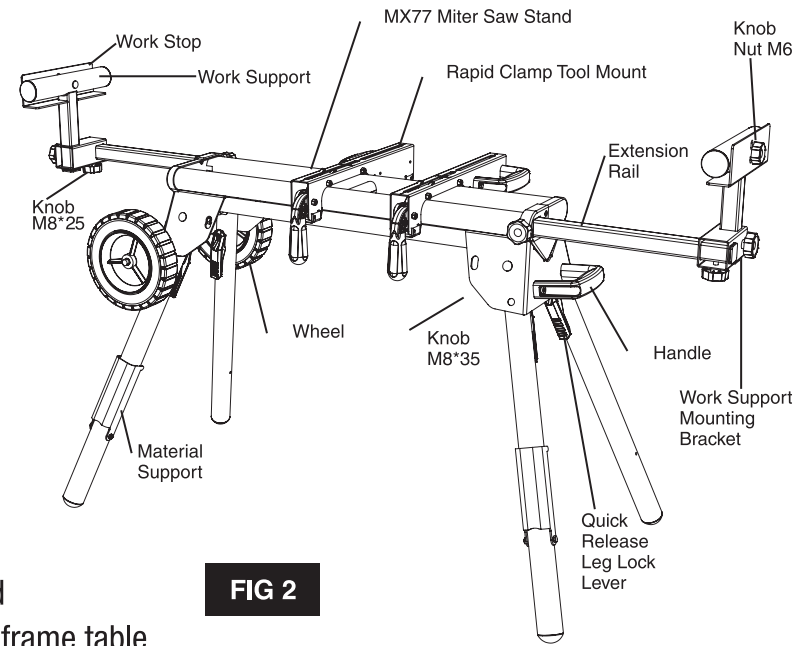
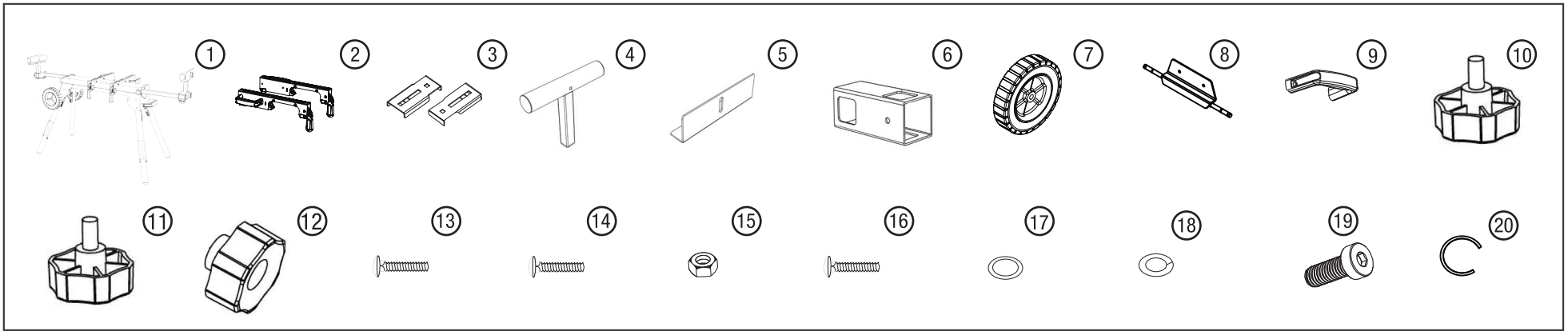

FIG 2

PARTS LIST

PART #	DESCRIPTION	QTY
1	MITER SAW STAND	1 pcs
2	RAPID TOOL CLAMP	2 pcs
3	MOUNT ADAPTER	2 pcs
4	ROLLER ACCESSORY	2 pcs
5	L PLATE	2 pcs
6	ROLLER ELBOW	2 pcs
7	WHEEL	2 pcs
8	AXLE PLATE	1 pcs
9	HANDLE	1 pcs
10	KNOBS M8*35	2 pcs

PART #	DESCRIPTION	QTY
11	KNOBS M8*25	4 pcs
12	KNOB NUTS M6	2 pcs
13	CARRIAGE BOLT M8*55	2 pcs
14	CARRIAGE BOLT M8*20	2 pcs
15	NUT M8	12 pcs
16	CARRIAGE BOLT M8*60	4 pcs
17	WASHER #8	12 pcs
18	SPRING WASHER #8	12 pcs
19	BOLT M8*25	4 pcs
20	C-CLIP	4 pcs



FEATURES

Your Contractor Miter Saw Work Station is loaded with standard features all designed and engineered to maximize the functionality and flexibility of your Work Station.

STANDARD FEATURES

- Rapid Clamp Tool Mounts
- Adjustable Material Supports
- Wheels for for easy transportation

ASSEMBLY INSTRUCTIONS

Read all assembly instructions completely before attempting assembly.

ATTACHING THE WHEELS

See Figure 3

1. Using pliers squeeze a C-clip over the inner groove closest to the miter saw stand.
2. Place the wheel onto the axle and secure it using another C-clip toward the end of the axle.
3. The C-clips should snap into place and hold the wheel onto the axle.

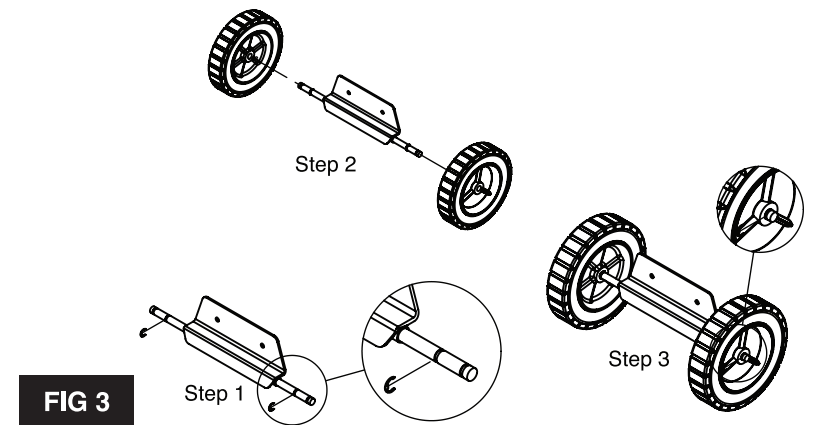

FIG 3

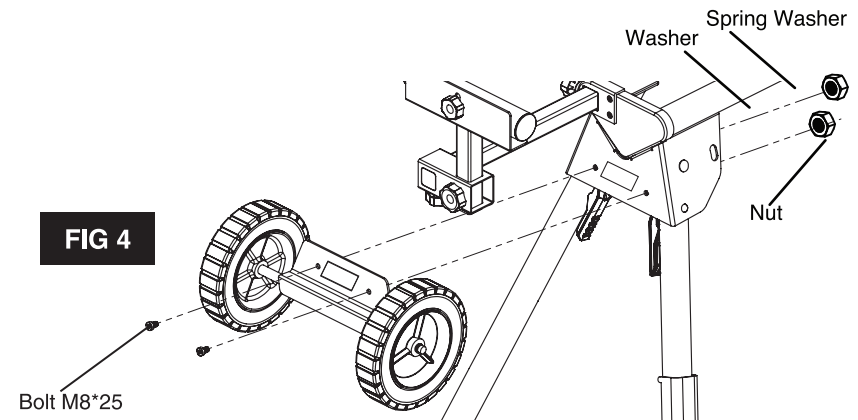

FIG 4

ATTACHING THE AXLE PLATE

See Figure 4

1. Place (2) M8 bolts through the holes in the axle plate.
2. Place the axle plate onto the end of the miter saw stand making sure that the bolt runs through the holes on the miter saw stand.
3. Place the washer and spring washer over each bolt on the back side of the miter saw stand.
4. Lift the miter saw stand to an upright position.
5. Tighten M8 nut over the washer until secure.

ATTACHING THE PULL HANDLE

See Figure 5

1. Place (2) M8 bolts through the holes in the plastic handle.
2. Place the handle onto the end of the miter saw and stand and make sure the M8 bolts pass through the holes in the body.
3. Place a washer and spring washer over each bolt exposed on the backside of the miter saw stand.
4. Lift the stand and place it in an upright position.
5. Tighten M8 nut over the washers until secure.

PREPARING THE STAND

See Figure 6

1. Lay the stand's top surface down on the floor with the folded legs on top.
2. Press the Quick Release Leg Lock Lever and rotate that leg up until the locking pin clicks into place.
3. Repeat with the remaining three legs.
4. Lift the stand and place it in an upright position.
5. Check to ensure the stand is stable and all the legs have the locking pins engaged.

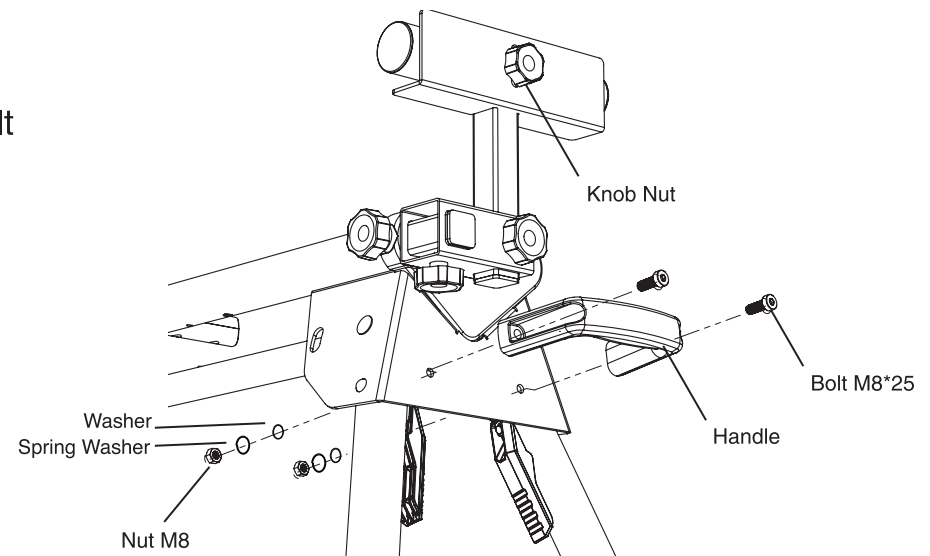

FIG 5

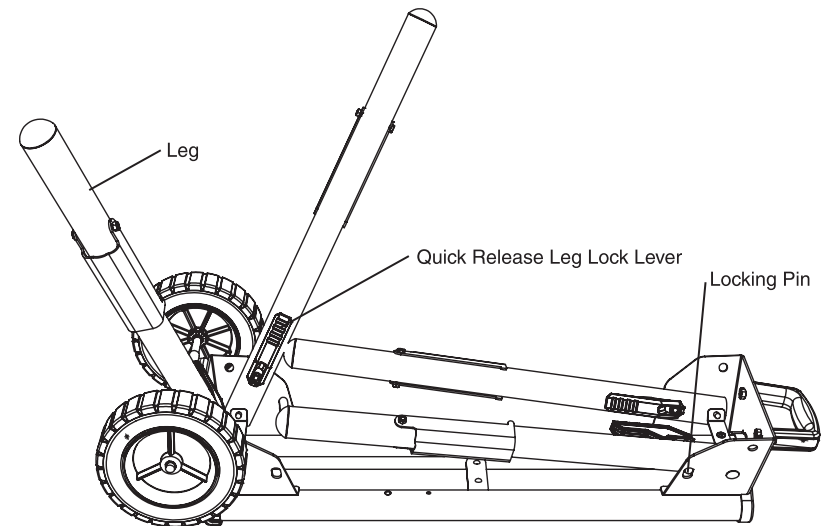

FIG 6

ATTACHING YOUR MITER SAW OR OTHER BENCH TOP POWER TOOL

See Figure 6

Various bench top tools can be used with your Contractor Miter Saw Work Station by attaching them to the Rapid Clamp Tool Mounts. Always position the saw to achieve maximum balance and stability. All four corners of the saw must be bolted to the tool mounts before use. Make sure bolts do not extend above the table of the miter saw.

1. Unplug the saw and lock the saw arm in the down position.
2. Place a tool mount underneath the saw, aligning the mounting holes on the miter saw base with the slot in the top of the tool mount.
3. Feed a carriage bolt up through both the tool mount and a mounting hole in the saw.
4. Secure in place using a flat washer, spring washer and nut.
5. Repeat through the other end of the tool mount.
6. Place the second tool mount underneath the other side of the saw, aligning the mounting holes on the miter saw base with the opening in the tool mount.
7. Install carriage bolts as previously described.
8. After making sure both tool mounts are parallel to each other, finger tighten all four nuts to hold in position.

NOTE: If the saw has holes that do not line up with the slots in the tool mounts, use the offset mounting brackets.

OFFSET MOUNTING

See Figure 7

Offset Mounting Bracket for Miter Saws and/or Power Tools with an irregular mounting hole pattern.

Instructions: Secure offset mounting brackets as shown. Brackets can be used on the front or rear of the Rapid Clamp Tool Mounts.

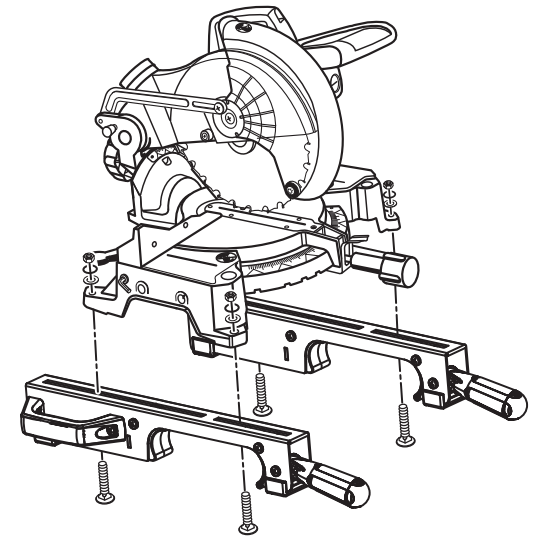

FIG 6

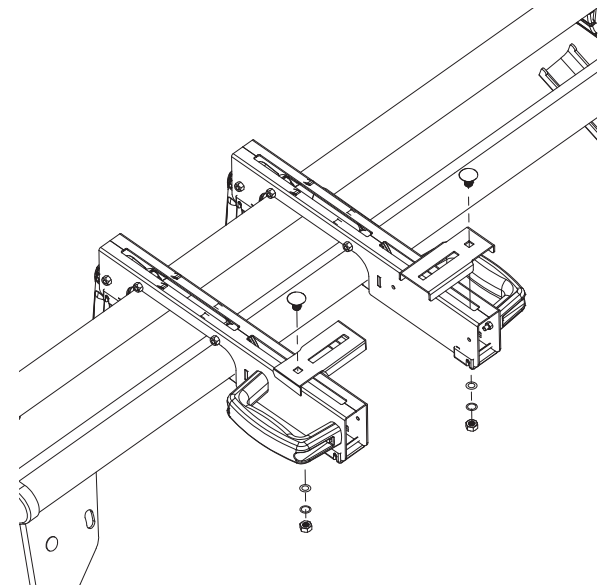

FIG 7

MOUNTING THE MITER SAW TO THE STAND

See Figure 8

Use the handles located at the rear of the tool mounts to aid in installing or removing saw and tool mount assembly.

1. Lift the saw and tool mount assembly, allowing the assembly to tilt slightly toward your body.
2. While still tilted toward you, hook the front edge of the tool mount assembly onto the front rail of the stand.
3. Lower the tool mount assembly to allow the rear edge of the tool mount to seat fully over the rear rail.
4. Lock the tool mounts in position by lowering the locking levers.

NOTE: Continue to hold the tool mount assembly with one hand until both levers are securely locked.

5. Check position and adjust if necessary to make sure the weight of the saw is evenly balanced over the rails.
6. Ensure the saw is seated and locked in position, then securely tighten the four nuts holding the saw to the tool mounts.

TO REMOVE SAW FROM STAND

See Figure 9

1. Raise the locking levers to unlock the saw and tool mounts.
2. Lift away from the rear rail of the stand to disengage.
3. With the assembly tilted slightly toward you, lift the assembly to disengage from the front rail of the work station.

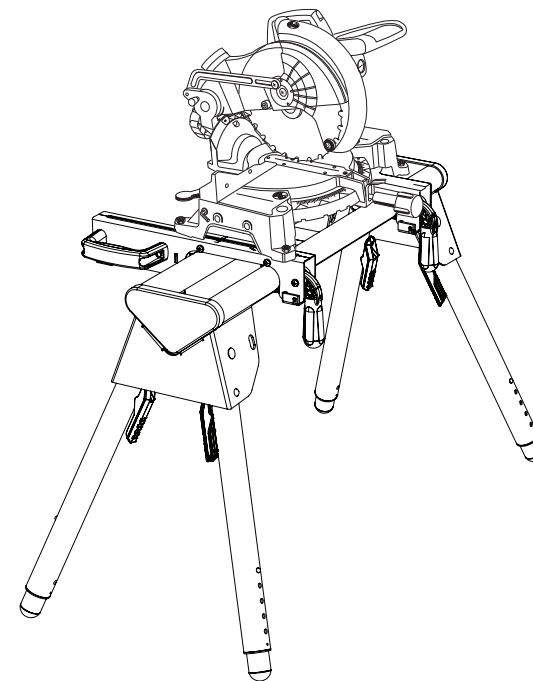

FIG 8

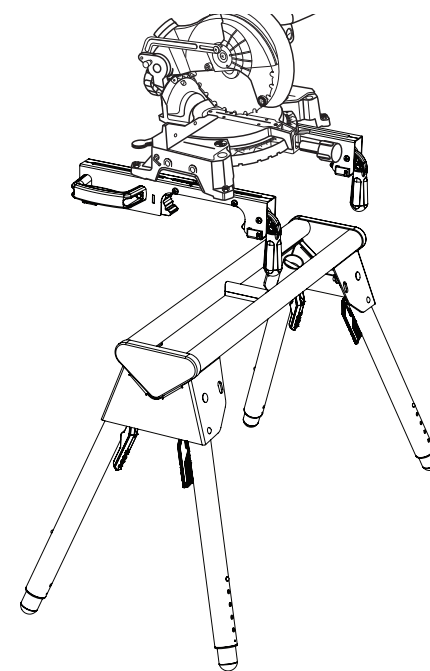

FIG 9

TRANSPORTING AND STORING

See Figure 10

1. Before storing or transporting, make sure all attachments are secure and bench top tool is removed.
2. Collapse legs and make sure they are locked into the up position.
3. Use the handle that is located on the end of the product for transporting.
4. Pull up on the handle and tilt workstation until weight is distributed evenly onto wheels.

TOOL MOUNT ADJUSTMENT SCREW

Most plastic tool mounts are designed to fit snugly over the stand rails. With the locking levers in the lowered (locked) position, you should not be able to remove the saw and tool mount assembly from the rails. If the saw and tool mount can be removed from the rails when the levers are locked, the tool mount adjustment screws need to be tightened. If the saw and the tool mount assembly will not fit over both rails, the bracket adjustment screws need to be loosened.

NOTE: The saw should be removed from the tool mounts before attempting to tighten or loosen the tool mount adjustment screws.

TO ADJUST

See Figure 11

1. Use a wrench to slightly loosen the nut.
2. Turn the screw with a Phillips screwdriver. Rotate clockwise if the tool mount assembly needs to be tightened or counterclockwise if the assembly needs to be loosened.
3. Install the tool mount on the Contractor Miter Saw Work Station rails and lower the locking lever to check the adjustment.
4. When the correct position is achieved, tighten the nut with a 10mm open-ended wrench to secure.
5. Repeat steps 1 through 4 to attach the second tool mount.

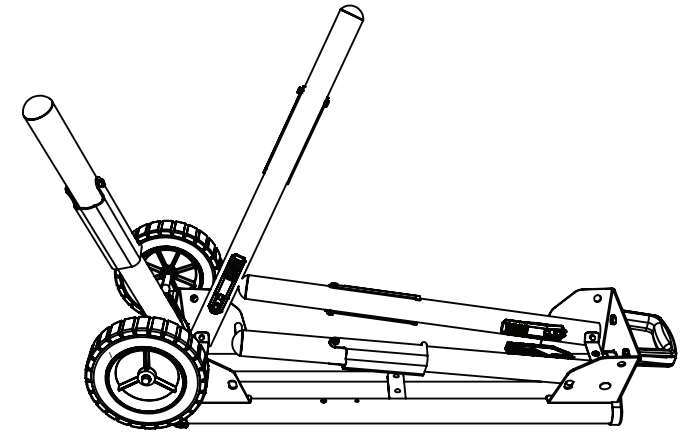

FIG 10

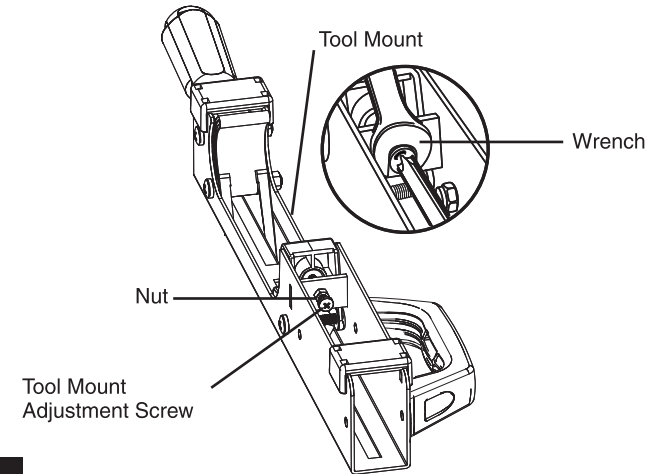

FIG 11

GENERAL MAINTENANCE

Avoid using solvents when cleaning plastic parts. Most plastics are susceptible to damage from various types of commercial solvents and may be damaged by their use. Use clean cloths to remove dirt, dust, oil, grease, etc.



**LIFETIME | LIMITED
WARRANTY**

PROTOCOL™ Contractor Miter Saw Work Station is backed by a Limited Lifetime Warranty. This warranty covers manufacturer defects and workmanship. The warranty excludes misuse or abuse and normal wear and tear. Exclusion is not allowed in some states and may not apply. This warranty gives you specific legal rights, and you may have other rights, which vary from state to state.

JS PRODUCTS, INC. | 6445 MONTESSOURI STREET | LAS VEGAS, NV 89113
800.255.7011 | FAX: 775.898.8773 | FOR MORE PRODUCTS AND ACCESSORIES GO TO WWW.PROTOCOLEQUIPMENT.COM