



*The* Industry Leader in Dust Collection

# Dust Deputy Deluxe 2.5 Dust Deputy Deluxe

# AXD000004B

# AXD250004



Patents: [www.oneida-air.com/patents](http://www.oneida-air.com/patents)

Rev: F 20240126LL

Appearance may vary slightly

Doc. # ZBM000036DELC



# System Start-Up Information

---



## **READ THE SAFETY PRACTICES INSTALLATION AND MAINTENANCE INSTRUCTIONS AND YOUR WET/ DRY VACUUM'S OWNER'S MANUAL BEFORE ASSEMBLING AND USING THE DUST DEPUTY**

1. DO NOT use to pick up anything that is burning or smoking, such as cigarettes, matches, or hot ashes.
2. DO NOT collect flammable or combustible liquids, gases, or explosive dusts, such as gasoline or other fuels, lighter fluid, cleaners, oil-based paints, natural gas, hydrogen, coal dust, magnesium dust, grain dust, aluminum dust, sugar dust, flour dust or gun powder.
3. Can be used for collecting non-flammable liquids.
4. DO NOT use or store near hazardous materials.
5. DO NOT operate the in areas where explosion risks are high. Areas of high risk include, but are not limited to, areas near pilot lights, open flames, or other ignition sources.
6. ALWAYS wear a NIOSH approved respirator when emptying dust bins and during operation. Dust created by machinery operations may cause cancer, birth defects, or long-term respiratory damage. Be aware of dust hazards associated with each workpiece material.
7. NEVER introduce sparks or sources of ignition.
8. ENSURE all equipment and connections are electrically grounded.
9. ONLY operate in locations that has a fire extinguisher available nearby.
10. ALWAYS dispose of waste in a fire safe area after each use. NEVER leave wood dust in a building or vehicle. Wood dust mixtures are highly flammable and can be explosive.



## **SOME DUSTS ARE HIGHLY FLAMMABLE OR EXPLOSIVE. LEARN/ KNOW WHAT YOU ARE DEALING WITH. FOLLOW ALL LOCAL, STATE, FEDERAL & NFPA CODES AND GUIDELINES.**

# Dust Deputy Deluxe Dimensions

Nominal dimensions shown. Dimensions subject to slight variations in manufacturing.

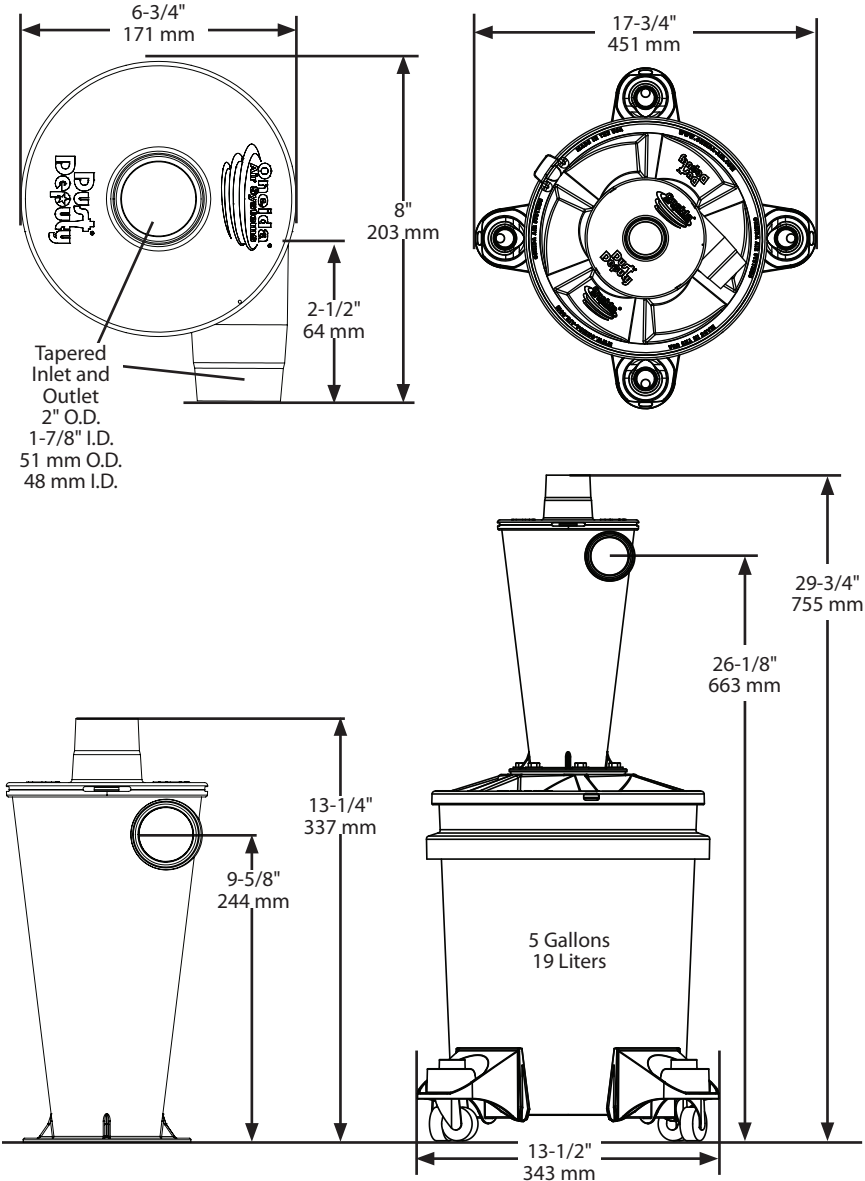

# Dust Deputy 2.5 Deluxe Dimensions

Nominal dimensions shown. Dimensions subject to slight variations in manufacturing.

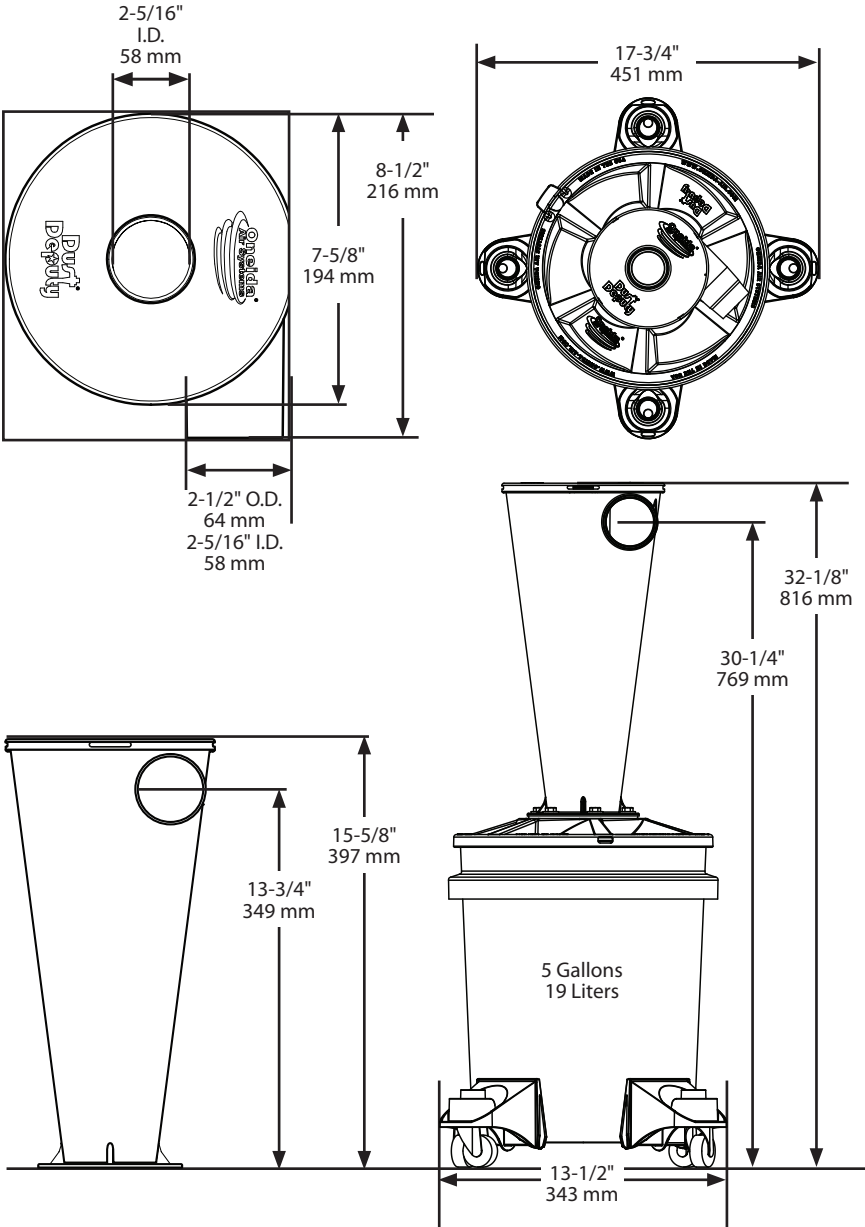

# System Contents

ID	Part number	Part description	Qty
A	VXC110002 VXC150225	Anti-Static Cyclone 2.5 Anti-Static Cyclone	1
B	AXG000004A	Cyclone Gasket	1
C	VFA050015	Metal Grounding Tape	30"
D	AHX000026	Cyclone Mounting Pack	1
D1	AFB252075	1/4" - 20 x 3/4" Hex Head Bolt	6
D2	AFW025000	1/4" Flat Washer	6
D3	AFT000011	1/4" Hex Nut	6
E	SDL050002	Lid with center and bolt holes	1
F	SDS050002	5-Gallon, 100-Mil, Bucket	1
G	RGF025016	Gasket	1
H	AFQ080101	Double Sided Tape	1
I	RHB00000	Caster Mounts (4 Pack)	1
J	RHC158716	Casters (4 Pack)	1
K	RHS000004	Tether Pack	1
K1	AFS080375	#8 x 3/8 Sheet Metal Screw	1
K2	AFB148000	D ring with clip	1
K3	AFC000007	PSA Retainer Clip	1
K4	AFB100000	Split ring	1
K5	AFH343800	Lanyard	1
L	AXD200036A	2" x 36" Hose	1
M	AXD600103A	2" Elbow	2
<b>INCLUDED ONLY WITH DUST DEPUTY DELUXE (AXD000004B)</b>			
N	ACB320000	Clamp Band	1
O	AF0990225	O Ring	2

# System Contents (Continued)

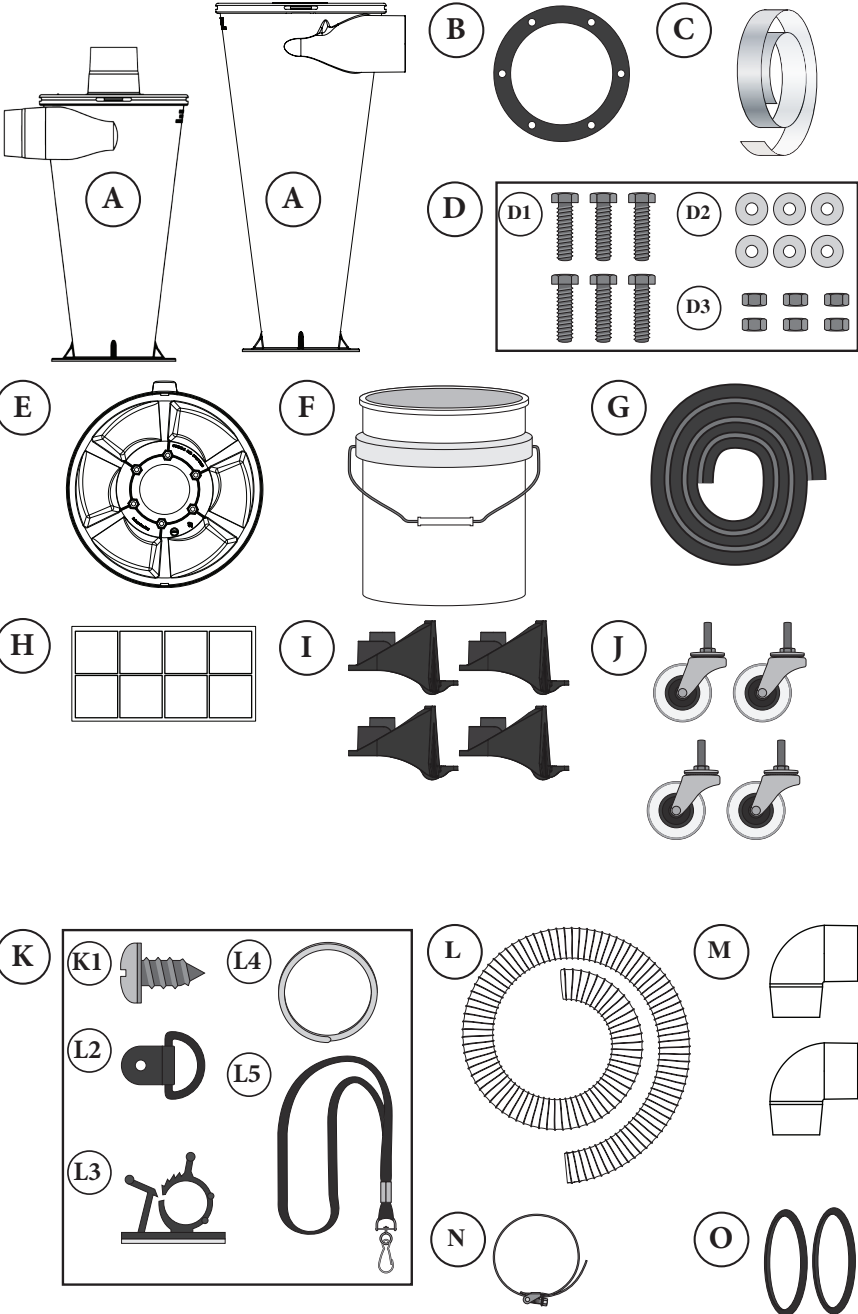

# Assembly Instructions

## You will need the following:

- Power Drill
- 1/4" Drill Bits
- 1/2" Open End Wrench
- 7/16" Open End Wrench
- Wet/Dry Vacuum
- Vacuum hose adapters

**1** Apply the Gasket (G) onto the Lid (E) along the underside of the rim's circumference. [FIG. 1a & 1b]

*Note: The Gasket ends should firmly butt up against each other to avoid air leaks [FIG. 1b]. Dust collection systems cannot operate effectively if there isn't a complete seal [FIG. 1c]. There must be NO air leaks.*

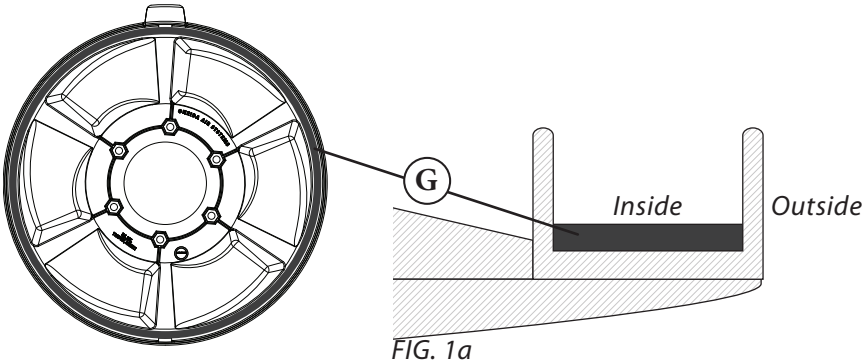

**Correct Installation**  
Gasket connects; Ends firmly butt up against each other.



FIG. 1b



**Incorrect Installation**  
Gasket does not connect; Gap between the ends.



FIG. 1c

# Assembly Instructions (Continued)

- 2 Turn the Cyclone (A) upside-down. Place the Gasket (B) on the base of Cyclone and align all the holes. Place the topside of the Lid (E) against the Gasket and align all the holes. Secure the Cyclone, Gasket and Lid together using six Bolts (D1), six Washers (D2), and six Hex Nuts (D3) as shown in [FIG. 2].

*Note: Tighten hardware evenly to eliminate air leaks. DO NOT OVERTIGHTEN! On the Lid there are hex-shaped recesses for ease of installation of the nuts.*

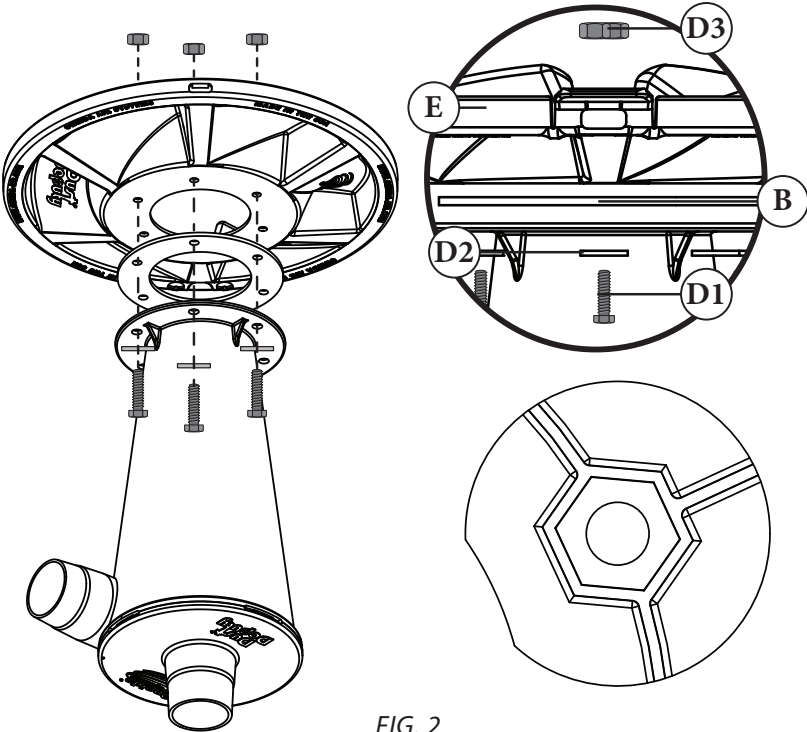
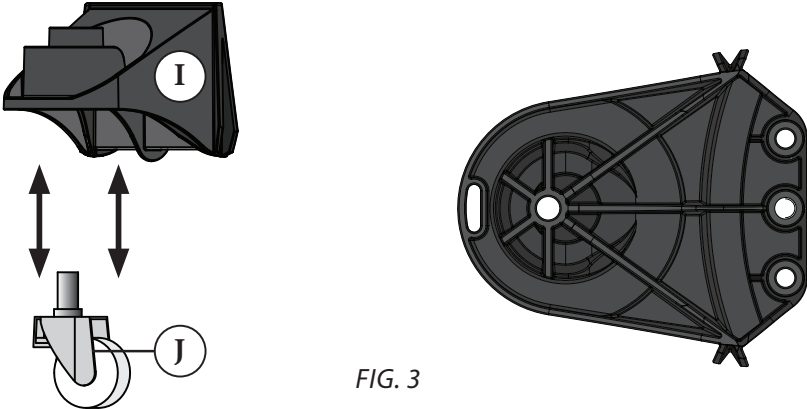

FIG. 2

# Assembly Instructions (Continued)

- 3 Insert the Casters (J) into the Caster Mounts (I). Apply pressure and twisting motion until Wheels snap into place [FIG. 3].



- 4 Ensure that the surfaces on the Bucket (F) and Caster Mounts (I) are clean and dry. Remove a square from the Double Sided Tape (H) and apply to the Caster Mount in the recessed location at each corner [FIG 4].

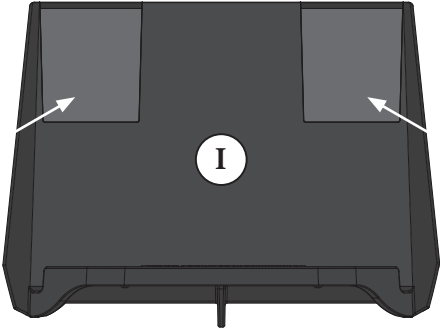

# Assembly Instructions (Continued)

---

- 5 Flip the Bucket (F) upside down and arrange the Caster assemblies evenly around the bottom edge [FIG. 5].

*Note: We recommend arranging the Caster Assemblies at 90° increments from each other for the most stable setup.*

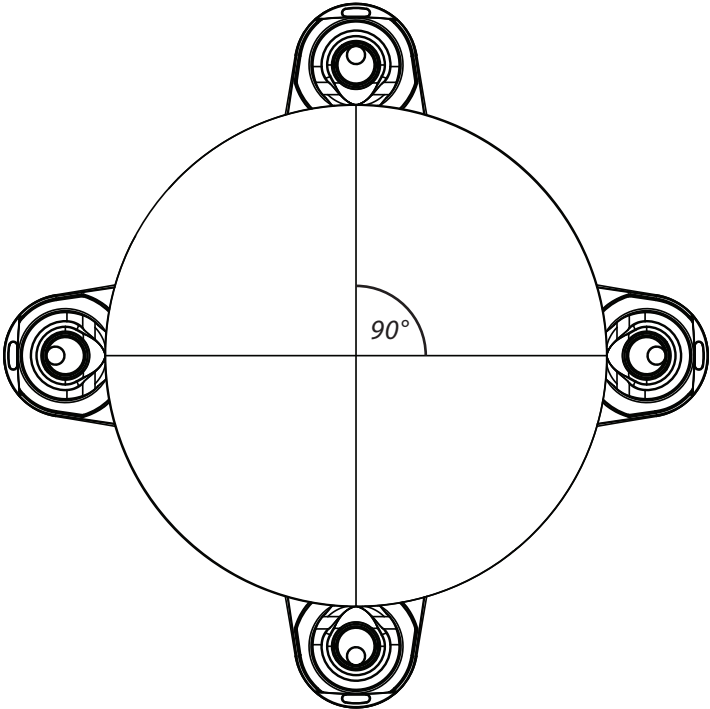

FIG. 5

# Assembly Instructions (Continued)

**6** The Caster assemblies must be adhered to the Bucket (F) with a single smooth motion so that the bottom edge of the Bucket fits within the recessed channel of the Caster Mount [FIG. 6a].

Remove the backing paper from the Double Sided Tape (H) on the Caster assembly. Rest the lip of the Caster assembly against the bottom of the Bucket and then rotate the Caster assemblies flush against the side of the Bucket. Press firmly for a secure fit [FIG. 6b].

*Note: To more securely attach the Caster Mounts to the Bucket we recommend a 1/4"-20 nut and 1/4"-20 x 1/2" bolt.*

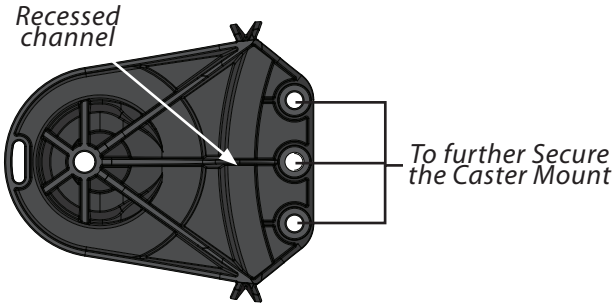

FIG. 6a

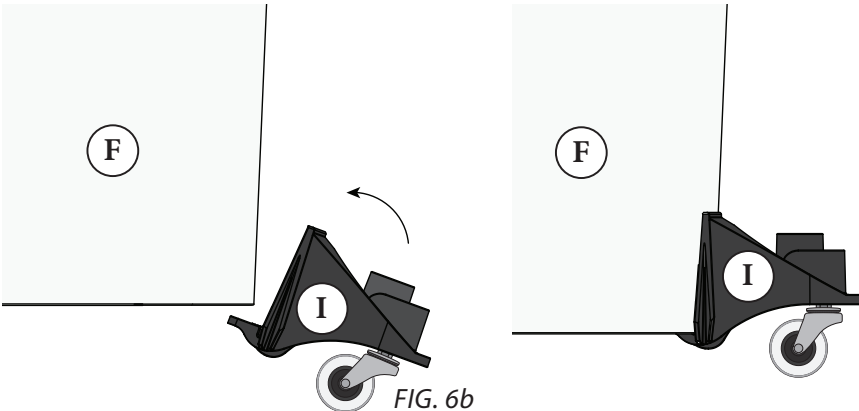

FIG. 6b

## Assembly Instructions (Continued)

7

The Dust Deputy Deluxe can be attached to your wet/dry vacuum to move as one unit. The Tether Pack (K) includes a variety of components to meet the needs of any make/model vacuum. Examine your vacuum configuration first to review what option works best. You are not limited to the below options:

- a. Attach the Split Ring (K4) to the slot on the Caster Mount (I) and attach the Retainer Clip (K3) onto your vacuum's foot caster. Then loop the Lanyard (K5) around your vacuum's foot caster and through itself and the Retainer Clip. Finally, clip the Lanyard to the Split Ring [FIG 7a].
- b. Attach the D ring (K2) to the vacuum with the Sheet Metal Screw. (K1) Then loop the Lanyard (K5) around the slot on the Caster Mount and through itself. Finally, clip the Lanyard to the D ring [FIG 7b] [FIG 7c].

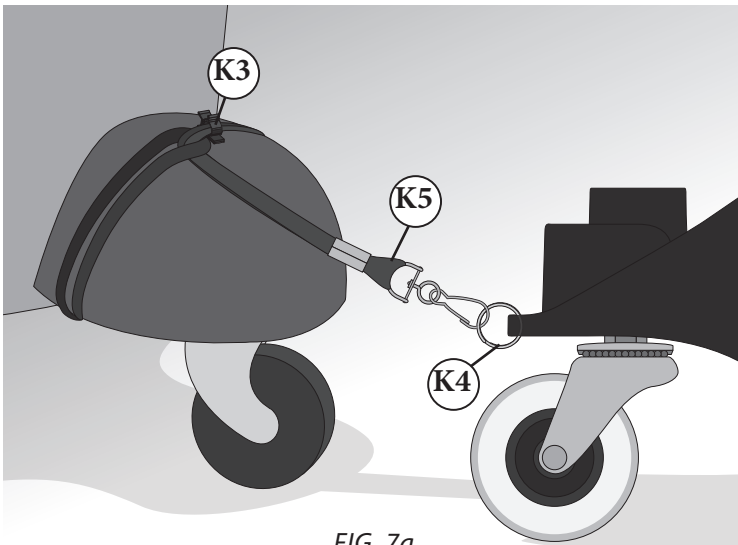

FIG. 7a

# Assembly Instructions (Continued)

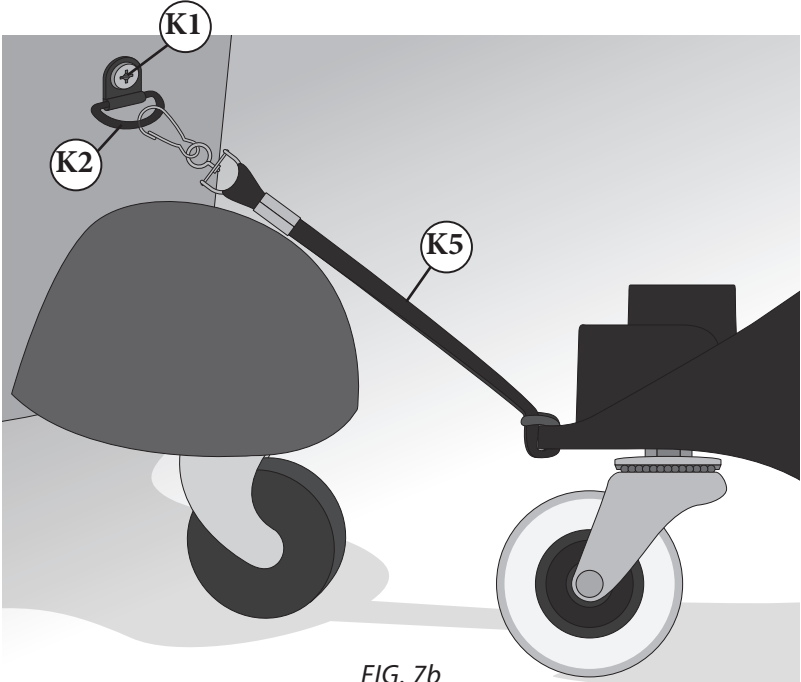

FIG. 7b

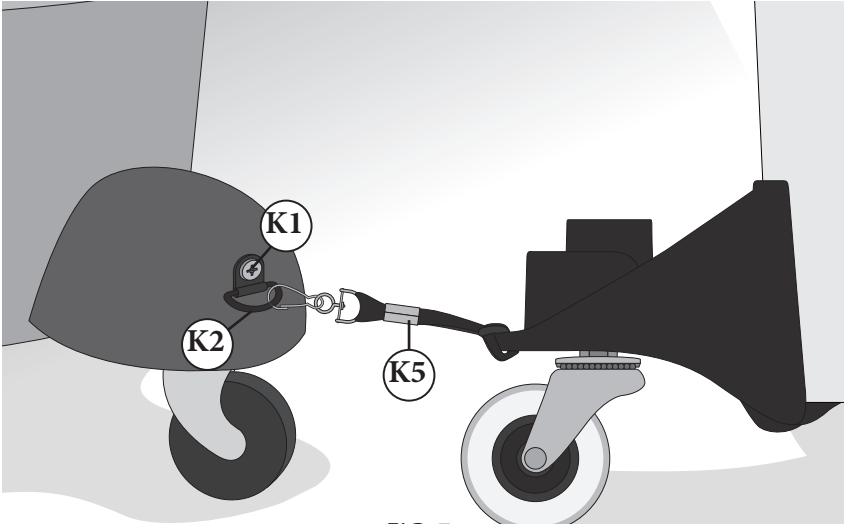

FIG. 7c

# Assembly Instructions (Continued)

- 8 Snap the Cyclone (A) and Lid assembly onto the Bucket (F) and ensure it's fully seated [FIG. 8a]. The lid will make an audible click as it seals close.

*Note: When emptying the Bucket, lift up on latch and pull up on the lid to release the cyclone assembly from the 5 gallon Bucket [FIG. 8b]. It is normal for the lid to fit loosely on the bucket; it will seal securely under vacuum pressure once your wet/dry vac is turned on.*

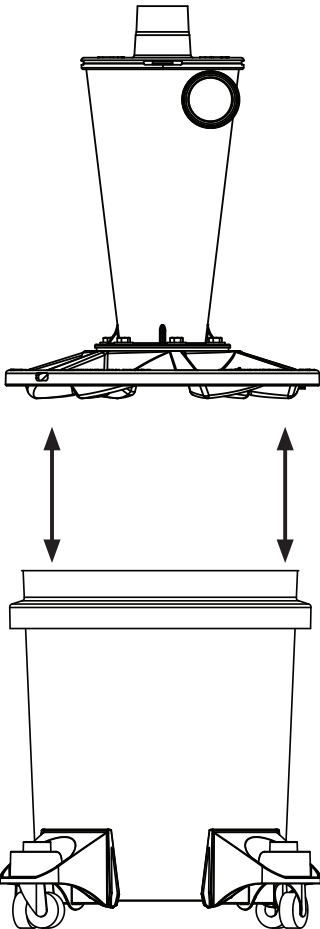

FIG. 8a

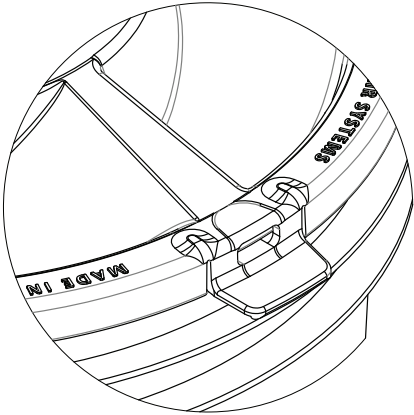

FIG. 8b

# Assembly Instructions (Continued)

- 9 Attach one Elbow (M) to the top outlet of the Cyclone (A) and affix Hose (L) to the tapered end of the Elbow. Attach the other open end of Hose to the second Elbow and attach to the inlet of your wet/dry vacuum.

Connect the Cyclone's inlet (sideways facing port) to your dust producing tool with your vacuum's hose or ductwork [FIG. 9a].

*Note: If your vacuum hose is not tight on the inlet or it keeps pulling off, use the Clamp Band (N) and/or the two O-Rings (O) [FIG. 9b] [FIG. 9c].*

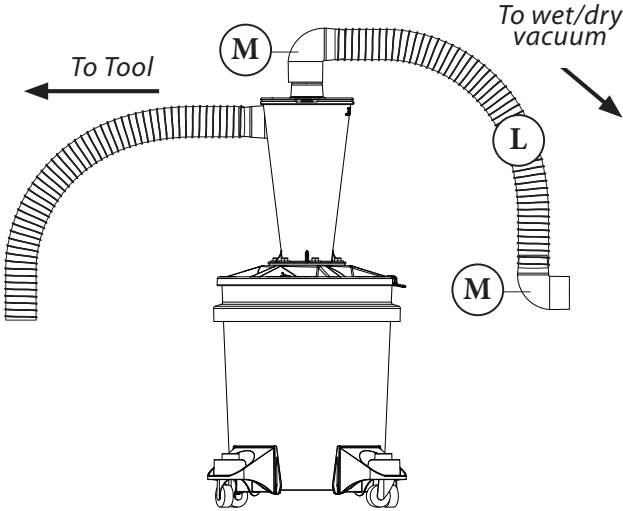

FIG. 9a

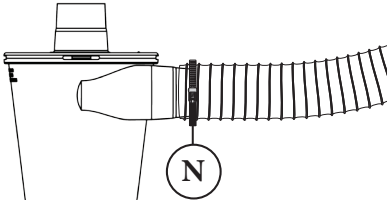

FIG. 9b

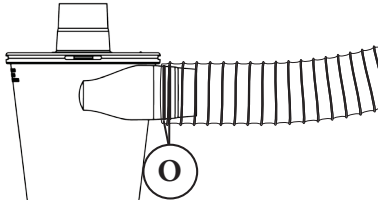

FIG. 9c

# Assembly Instructions (Continued)

**11** Make sure there are no air leaks at the connections. Review [FIG. 11] for common leak points.

*Note: Any air leak in the lid or drum will affect separation performance. Make sure to check your dust drum frequently so you do not overfill it. One option to check for air leaks is with a smoke test. Found at most hardware stores in the HVAC section. Introduce smoke around every leak point. If you see the smoke being drawn into the system, you've found an air leak that needs to be sealed.*

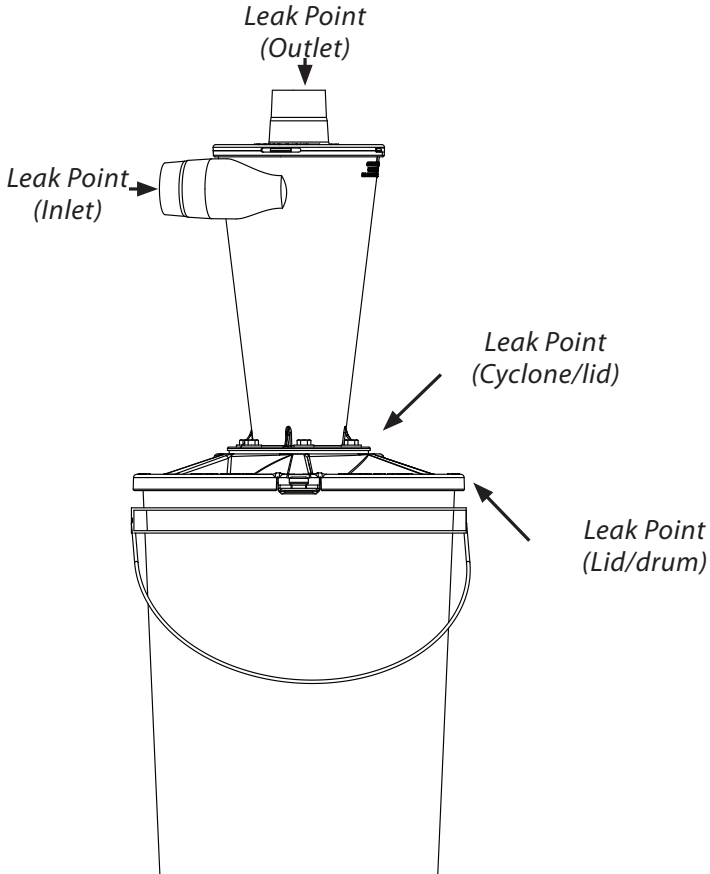

FIG. 11

# Alternate Sidecar Ideas

---



You are only limited by your imagination. Below are some alternate sidecar setups that customers have created.



# Adding Cyclones to Improve Performance

## Attach in Series

Increases particle efficiency and helps in very fine dust situations.

Top View

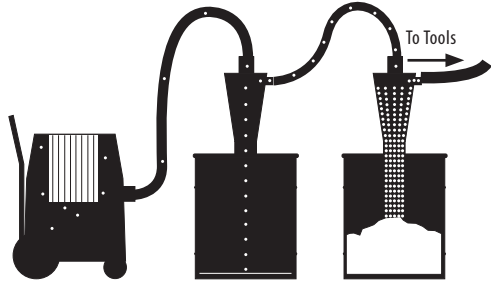

## Attach in Parallel

Same particle efficiency but increases the CFM.

Top View

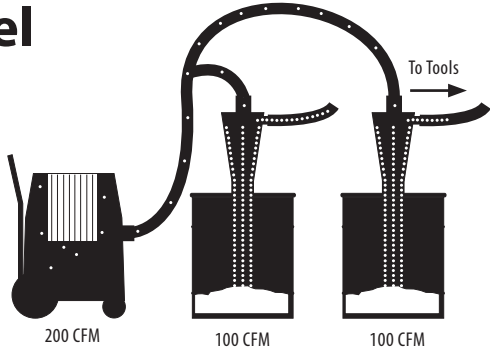
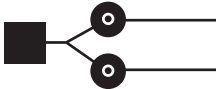

## Multiple Vacuums

More CFM/airflow to larger tools such as Table Saw, Jointer, and Planer.

Top View

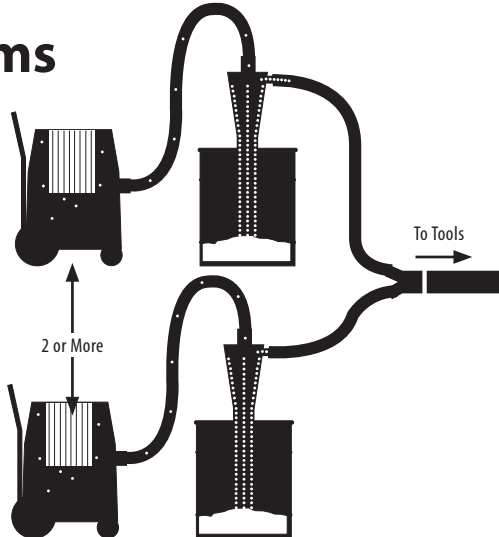
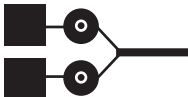

# Optional Grounding Instructions



Recommended for fine dust situations or electronically sensitive applications.

1

Install the Metal Tape (C) to the Cyclone (A) so that the inlet, outlet, and flange are attached by a continuous, conductive path. The tape should wrap 1/4" around the edge of each opening [FIG 12].

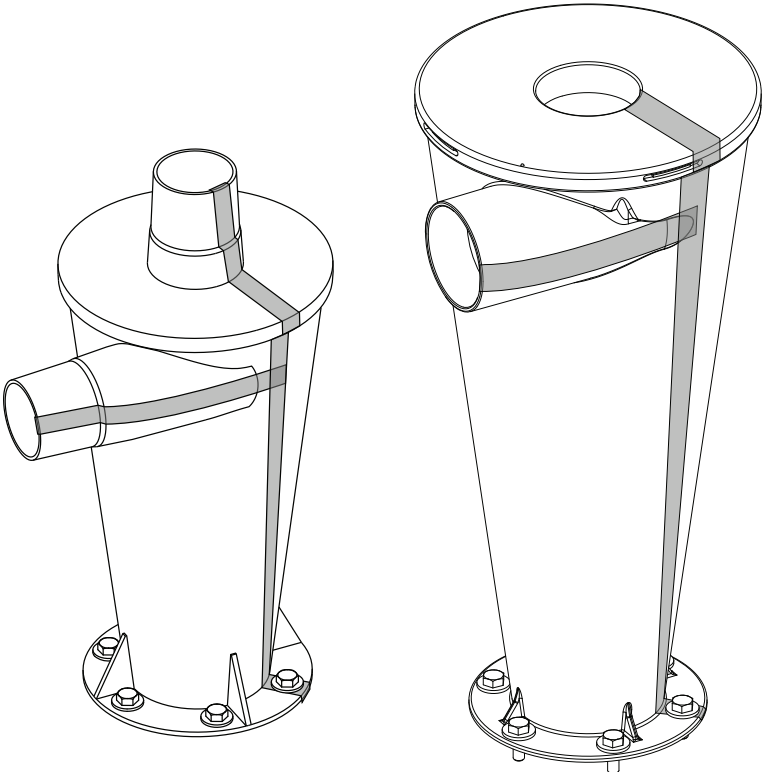

FIG. 12

# Optional Grounding Instructions (Continued)

- 2 For added grounding, attach a self-supplied wire with a ring terminal on one end and a washer tied to the other end when installing one of the bolts in step 2 on page 9. The wire must be long enough for the washer to lie on the floor [FIG 13].

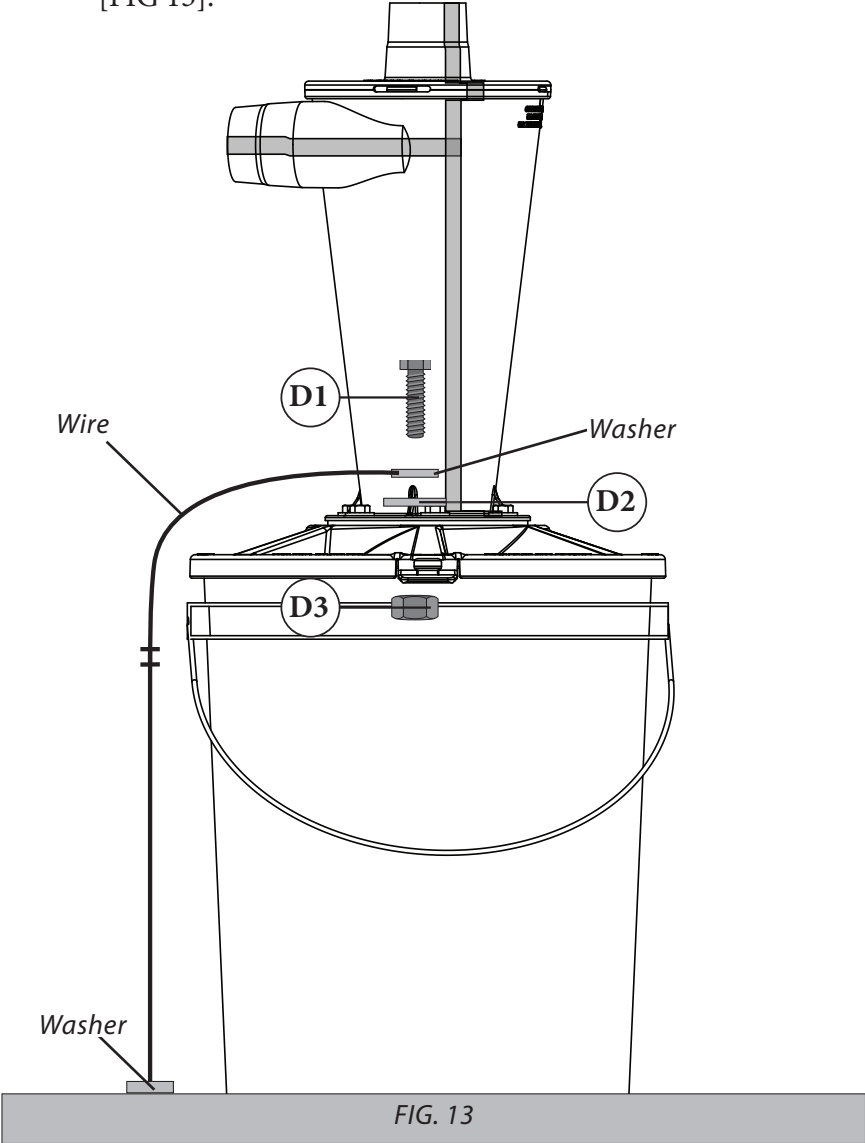

FIG. 13

# Troubleshooting

PROBLEM	CAUSE	SOLUTION
Not separating well. (Only a tiny amount of dust should reach the vacuum)	Air leaks in the drum	<ol style="list-style-type: none"> <li>1. Check for leaks between the lid and the dust drum.</li> <li>2. Check for holes or leaks in the dust drum.</li> <li>3. Check for leaks along the flange of the cyclone.</li> </ol>
Material swirls in cyclone and won't drop into the dust container.		
Material swirls in cyclone and won't drop into the dust container.	Collecting large bulky material	<ol style="list-style-type: none"> <li>1. Large, bulkier material might swirl. Restart or temporarily cut off air flow to drop material down.</li> </ol>
Low Air Volume	System clogged	<ol style="list-style-type: none"> <li>1. Clean vacuum and the vacuum filter per the manufacturer's specs.</li> <li>2. Check all hose connections for a blockage in the hose.</li> </ol>
Drum Collapsing	Blocked airflow	<ol style="list-style-type: none"> <li>1. Ensure the end of the hose isn't blocked.</li> </ol>
Hose Pulling off	Hose connections not tight	<ol style="list-style-type: none"> <li>1. Due to the varied hose diameters, flexible couplers can be used. They are available at local hardware stores in the plumbing section.</li> <li>2. Use a hose clamp.</li> <li>3. Wrap the inlet and outlet of the Dust Deputy with a layer of electrical tape to increase the friction fit.</li> <li>4. Secure hose with a sheet metal screw.</li> </ol>

## FAQ

---

### **What do I need to hook up my Dust Deputy to my vacuum?**

Our Dust Deputy Deluxe Kit is ready to go right out of the box for most wet-dry vacuums. However, not all wet-dry vacuums are identical and may need an adapter to attach. Please visit our site for adapters at [oneida-air.com/flex-hose/adapters](http://oneida-air.com/flex-hose/adapters).

You can also find adapters at your local hardware store. Look in the plumbing section for a sleeve or adapter. There are many different sizes and configurations.

### **What vacuum do you recommend for the Dust Deputy?**

The Dust Deputy can be used with any make, model, or size wet/dry vacuum with an inlet ranging from 1.5" to 2.5" in size. The 2.5 Dust Deputy has female inlet and outlet ports (2.25" I.D.) that readily accept the 2.5" cuffed hose fittings standard with shop vacuums commonly used for dust collection. We recommend that it has an airflow rating of at least 50 CFM to ensure optimum dust separation performance.

### **Can I use this upstream of a 650 CFM single stage dust collector? Can I use the Dust Deputy with my 4" hose / port?**

No. The smaller Dust Deputy cyclone is intended for use with HIGH pressure and LOW airflow systems, such as wet/dry vacuums, with port sizes 2.5" diameter and smaller. It would not be suitable for a HIGH airflow, LOW pressure system (i.e. dust collector). Connecting 4" tools to the Dust Deputy cyclone's 2" ports will result in significant losses in airflow and suction power.

Single stage dust collectors and larger ports (4" and larger) will require one of our Super Dust Deputy cyclones. Match the cyclone based on the size of your dust collector's intake.

## **FAQ (Continued)**

---

### **How do I get the gasket out of the cyclone?**

Use needle-nose pliers or tongs if you cannot simply reach your hand into the bottom of the cyclone and pull it out. **NEVER REMOVE THE TOP PORTION OF THE DUST DEPUTY!**

### **Can I remove the top portion of the Dust Deputy?**

No, it is not advised and can cause damage to the cyclone and is not covered under warranty.

### **The top portion of the Dust Deputy is detached. Is there a way to fix it?**

Please contact our customer service department for assistance at 1-866-387-8822 or [support@oneida-air.com](mailto:support@oneida-air.com)

### **Is the Dust Deputy food-grade safe?**

No, the raw material is rated food-grade safe, but the additional anti-static material and the factory it's manufactured in are not rated food safe.

### **Can I use this cyclone with smoldering or abrasive debris?**

No. This cyclone is designed for use with light debris such as wood dust. For applications with highly abrasive or smoldering materials, we recommend our steel, Heavy-Duty Dust Deputy kits instead.

### **Does the Dust Deputy work with water?**

The Dust Deputy can be used with nearly any wet or dry material to cyclonically separate waste from the air stream. Some particularly viscous liquids may have trouble spinning inside the cyclone so use caution before sucking them up into your vacuum.

### **What is an anti-static material?**

This term refers to the range of conductivity that a material has. Anti-static materials range from 1010-1012 Ohms.

## FAQ (Continued)

---

### **Will the Dust Deputy cyclone work if my tool has its own fan blower?**

In most cases, yes - but the cyclone's efficiency will vary based on whether your vacuum is also turned on.

The Dust Deputy cyclone needs a consistent airflow rate to "spin" the dust out of the airstream; If your tool's fan blower is pushing air in while your vacuum is also sucking air out, this can disrupt the airflow rate and reduce the cyclone's separation performance.

In many cases, the fan blower on tools (such as planers) cannot be turned off. If that is the case for you, try collecting your dust with the vacuum turned off. In doing so you will be creating a positive pressure system as the tool's fan blower pushes air through the Dust Deputy cyclone. This method may not work with every vacuum.

### **What is the minimum air watts needed for the Dust Deputy?**

Rather than worrying about what specs your vacuum needs (e.g. air watts, cfm, static lift, etc.), we at Oneida Air Systems have a much simpler approach - simply match the size of your vacuum's inlet to the size of the Dust Deputy cyclone's ports.

The Dust Deputy cyclone's tapered 2" ports are designed to work with any make and model wet/dry vacuum on the market today, regardless of horsepower, wattage, etc. Most vacuums will have an inlet ranging from 1.5" to 2.5" in diameter - perfect for our cyclone.

If your vac's inlet accepts standard 2.5" hose fittings (actual OD=2.25"), the Dust Deputy 2.5 will optimize your vac's performance. If your vac's inlet accepts 2" or smaller diameter hose fittings, then the original Dust Deputy will be your best choice.

Keep in mind that every component installed onto your vacuum will have an effect on the system's suction power. That includes your hose, hose attachments, adapters, elbows, couplers, etc

## Accessories

---



### 2.5" x 4.5' Wire Reinforced Vacuum Hose

#AXD250054

- Crush-resistant, flexible hose with a smooth-wall inner lining that minimizes air resistance.



### Viper Vacuum Scraper Paint Removal Tool

#AXS001160B

- Ergonomic hand scraping tool with high-textured grip and reversible, tungsten-carbide blade.
- Hollow handle fits 1-1/4" to 1-1/2" vacuum hoses.



### Universal Dust-Free Router Hood

#AXH000001

- Collects router waste from both above and below the bit, virtually eliminating post-project cleanup.



### 1.5" x 6.5' Dust Extraction Hose Whip

#AHE000001

- This highly flexible vacuum hose fits onto the dust collection ports of common portable power tools. Includes 2.5" rotating swivel cuff.

# Warranty Information

## Limited Warranty – Activate online at [oneida-air.com/warranty](http://oneida-air.com/warranty)

Oneida Air Systems®, Inc. (OAS) warrants the Dust Deputy for a period of 1 year, to the original purchaser from the date of purchase, unless otherwise specified. Items not manufactured by Oneida Air Systems are limited to their own manufacturer's warranties. All electrical items such as magnetic starters, remotes, sensors, pumps, bin sensors, bag grippers, etc. and accessories are limited to 90 days. Oneida Air Systems warrants that the product will be free from defects in materials and workmanship.

This is Oneida Air Systems' sole written warranty and any and all warranties that may be implied by law, including any merchantability or fitness, for any particular purpose, are hereby limited to the duration of this written warranty. Oneida Air Systems does not warrant or represent that the merchandise complies with the provisions of any law or acts unless the manufacturer so warrants. This warranty does not apply to defects due directly or indirectly to misuse, negligence, accidents, abuse, repairs, alterations, improper wiring or lack of maintenance. In no event shall Oneida Air Systems' liability under this warranty exceed the purchase price paid for the product and any legal actions brought against Oneida Air Systems shall be tried in the State of New York, County of Onondaga.

The buyer is cautioned to install and operate Dust Collectors in accordance with prescribed Federal, State, OSHA, NFPA, local codes and regulations. This equipment should be installed/wired by a licensed electrician following all applicable codes. Local codes can be significantly different from national codes. The customer assumes the responsibility for contacting their insurance underwriter with regard to specific application requirements of venting or if additional fire protection and safety equipment may be required. Oneida Air Systems shall in no event be liable for death, injuries to persons or property or for incidental, and contingent, special, or consequential damages arising from the use of our product.

Oneida Air Systems makes every effort to accurately represent our products and prices, however Oneida Air Systems reserves the right to make changes to products and prices at any time. As a manufacturer, Oneida Air Systems reserves the right to change product specifications at any time in an effort to achieve better quality products.



**ONEIDA AIR SYSTEMS SHALL IN NO EVENT BE LIABLE FOR DEATH, INJURIES TO PERSONS OR PROPERTY OR FOR INCIDENTAL, AND CONTINGENT, SPECIAL, OR CONSEQUENTIAL DAMAGES ARISING FROM THE USE OF OUR PRODUCT.**



## Safety Warning - Please Read

Before Purchasing or Installing a dust collection system the buyer is cautioned to do so in accordance with prescribed Federal, State, Local, OSHA, NFPA, and any other applicable codes or regulations relating to the type of dust(s) you are collecting.

SOME TYPES OF DUST UNDER CERTAIN CONDITIONS HAVE THE POTENTIAL TO BE EXPLOSIVE.

Oneida Air Systems is not responsible for how the dust collector is used or installed. Dusts with deflagration or explosion risks, such as wood dust, may require additional safety equipment including but not limited to; venting, spark detection, suppression systems, back draft dampers or may require installation in an outside location or in a protected area away from personnel. The customer assumes the responsibility for contacting their insurance underwriter with regard to specific engineering controls or application requirements. (We suggest you reference NFPA 664, 654 and 68 codes for more information) Oneida Air Dust Collection Systems may not be suitable for some applications and are not designed to be used in explosive atmospheres. Oneida Air Systems equipment should only be installed and wired by a licensed electrician following all applicable local and national electrical codes.

Some dust created by power sanding, sawing, grinding, drilling, and other construction activities contains chemicals known to cause cancer, birth defects or other reproductive harm. Some examples of these chemicals are: Lead from lead-based paints; Crystalline silica from bricks, cement and other masonry products; Arsenic and chromium from chemically-treated lumber; etc.

Your risk from these exposures varies, depending on how often you do this type of work. To reduce your exposure to these chemicals, work in a well ventilated area, and work with approved safety equipment, such as those dust masks that are specially designed to filter out microscopic particles. Oneida Air Systems recommends using additional approved safety equipment such as an approved OSHA and NIOSH dust mask or respirator.



*The* **Industry Leader in Dust Collection**

**Thank you for your purchase  
of this American made product!**

Regardless of where you purchased your Oneida Air Systems' product, if you have any questions or issues with missing / damaged parts, please call Oneida Air Systems first to let us help resolve your problem. We fully stand behind the quality of our products and place the utmost value on the satisfaction of our customers.

We want to do everything possible to make your purchase and experience with Oneida Air Systems a good one!

**Customer Service Dept.**

**1-866-387-8822 • [support@oneida-air.com](mailto:support@oneida-air.com)**

1001 West Fayette Street, Syracuse, NY 13204 U.S.A.

Copyright © 2024 Oneida Air Systems, Inc.