

STANLEY[®]
Security Solutions

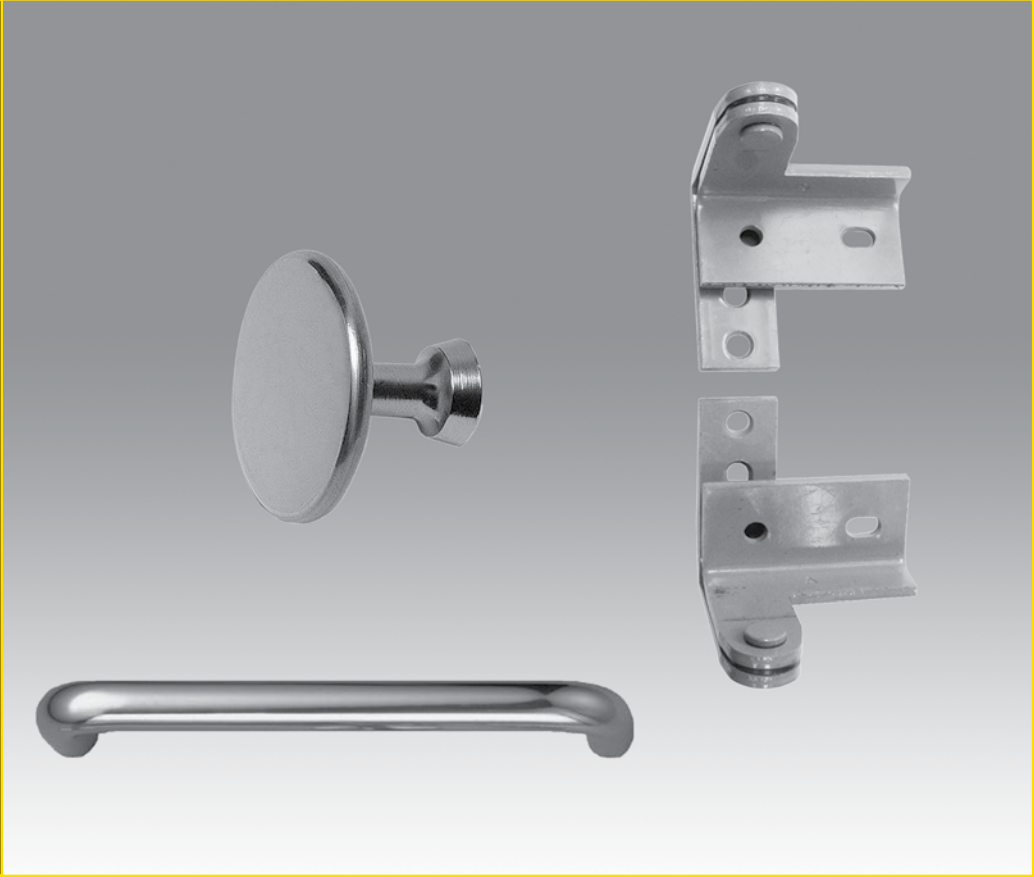

CABINET & WARDROBE

HARDWARE

STANLEY[®]

TABLE OF CONTENTS		Page
Company history		2
Wardrobe pivots		3, 4
Cabinet hinges		5
Cabinet pulls.....		5, 6
Cabinet knobs		6
Cabinet catches.....		7-10

COMPANY HISTORY



**The Stanly Works
New Britain, CT in 1843**

As a young man in 1843, Frederick T. Stanley founded The Stanley Works – a small company located in New Britain, Connecticut that manufactured hinges, bolts and other door hardware in a one-story wooden building.

Mr. Stanley’s vision was to create a hardware company with unsurpassed customer service, product innovation and integrity – and to offer products that would become the first choice among professionals around the world.

With the early success of this mission and an increasing demand for his high-quality goods, Mr. Stanley began exporting his products in the 1870s.

Today, Stanley is a global organization supplying hardware and tools for the architectural, consumer, industrial and residential markets worldwide. Utilizing state-of-the-art research, manufacturing and quality-control capabilities, Stanley continues to deliver the innovative, high quality products that have made the Stanley name synonymous with the highest craftsmanship and dependability for more than 165 years.

To our valued customers, we appreciate your loyalty over the years and proudly present our Architectural Hardware offering.

Commercial Customer Service: 1-800-337-4393
www.stanleyhardware.com

Wardrobe Pivots

340 – (ANSI A8753) – Standary duty – steel – plated or prime coated finishes

- For flush, recessed or overlay doors 1 1/8" (28.6 mm) to 1 3/8" (35 mm) thick not exceeding 75 lbs. (34 Kg)
- Only pivot of its type suitable for floor-to-ceiling doors
- Clean appearance, only hinge pivot shows when door is closed
- Door can be opened 180°
- Elongated screw holes make alignment simple
- Separable leaves of the top assembly permit fast installation
- Bushing at the pivot point assure smooth, silent operation

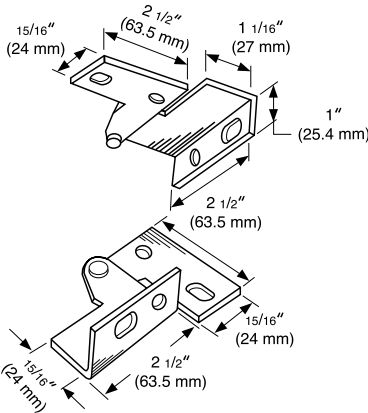
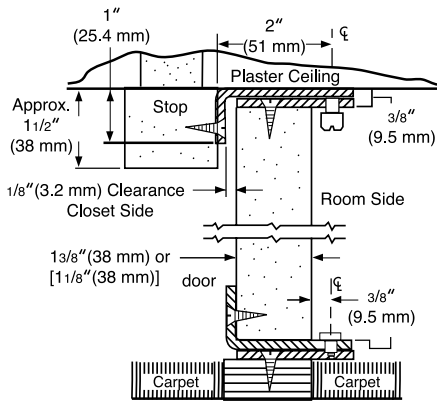

Right hand illustrated

Catalog Number	Gauge Inches	Gauge (mm)	Flat Head Wood Screws/ Per Set	Sets Per Box*	Sets Per Case	Case Weight Lbs.	Case Weight (Kg)
340	.131	(3.3)	8 - 12 x 3/4	1	20	17	(8)

*Set consists of one top hinge and one bottom hinge Handed. Specify right hand or left hand

341 – (ANSI A8773) – Standary duty – steel – plated or prime coated finishes

- For flush, or recessed doors 1 1/8" (28.6 mm) to 1 3/8" (35 mm) thick not exceeding 75 lbs. (34 Kg)
- Top header and bottom side frame mounted
- Suitable for floor-to-ceiling doors
- Door can be opened 180°
- Elongated screw holes for easy alignment
- Separable leaves of the bottom assembly for quick, easy installation
- Bushing at the pivot point assure smooth, silent operation
- Edge mortise door leaves – standard practice

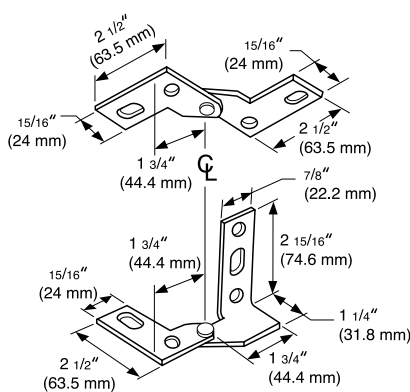
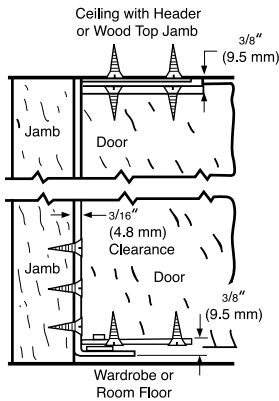

Right hand illustrated

Catalog Number	Gauge Inches	Gauge (mm)	Flat Head Wood Screws/ Per Set	Sets Per Box*	Sets Per Case	Case Weight Lbs.	Case Weight (Kg)
341	.131	(3.3)	7 - 12 x 1 2 - 12 x 1 1/4	1	20	14	(6.3)

*Set consists of one top hinge and one bottom hinge Handed. Specify right hand or left hand

CABINET AND WARDROBE HARDWARE

Wardrobe Pivots

327 – (ANSI A8782) – Heavy weight – steel – satin chrome (26D) plated

- For overlay doors 1 3/8" (35 mm) to 1 3/4" (44 mm) thick doors not exceeding 150 lbs. (60 Kg)
- Ideal for wardrobe doors
- Bearings take vertical and lateral loads
- Designed for mullion or face frame mounting
- Doors can be installed floor-to-ceiling
- Screw holes allow for vertical and horizontal adjustment
- Doors can be opened 180°
- Non-Handed

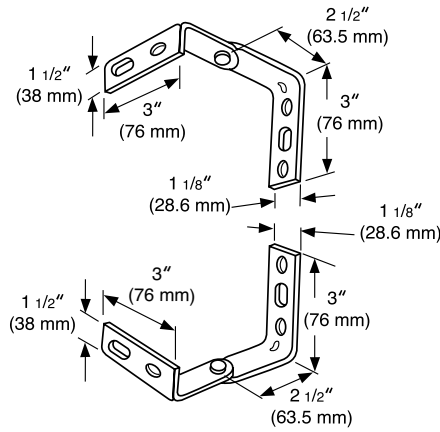
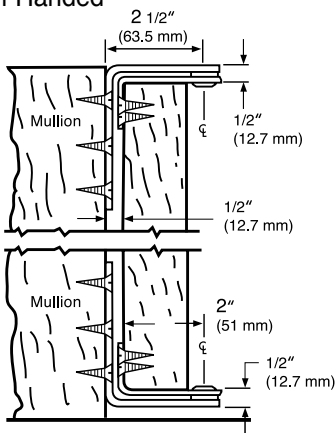

Catalog Number	26D EDP Number	Gauge Inches (mm)	Flat Head Wood Screws/ Per Set	Sets Per Box*	Sets Per Case	Case Weight Lbs. (Kg)
327	35-0043	.200 (5)	10 - 12 x 1 1/4	1	20	34 (15.4)

For other finishes contact factory.

342 – (ANSI A8783) – Standary duty – steel – plated or prime coated finishes

- For overlay doors 1 1/8" (28.6 mm) to 1 3/8" (35 mm) thick doors not exceeding 75 lbs. (34 Kg)
- Designed for mullion or face frame mounting
- Suitable for floor-to-ceiling doors
- Doors can be opened 180°
- Elongated screw holes for easy alignment
- Mortised door leaves – Standard practice
- Bushings at the pivot point assure smooth, silent operation
- Non-Handed

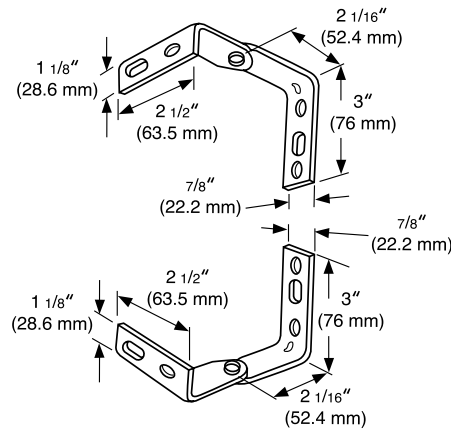
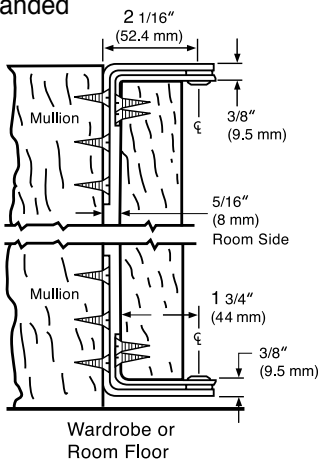

Catalog Number	Gauge Inches (mm)	Flat Head Wood Screws/ Per Set	Sets Per Box*	Sets Per Case	Case Weight Lbs. (Kg)
342	.131 (3.3)	10 - 12 x 1	1	20	18 (8)

Cabinet Hinges

1592 – Button tip – steel – satin chrome (26D) finish

HT1592 – Hospital tip – steel – satin chrome (26D) finish

- Made of heavy .088" gauge steel
- For 3/4" (19 mm) thick overlay doors
- Has interleaf design for close door fit
- Elongated screw holes for easy vertical and horizontal alignment

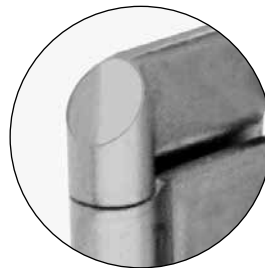
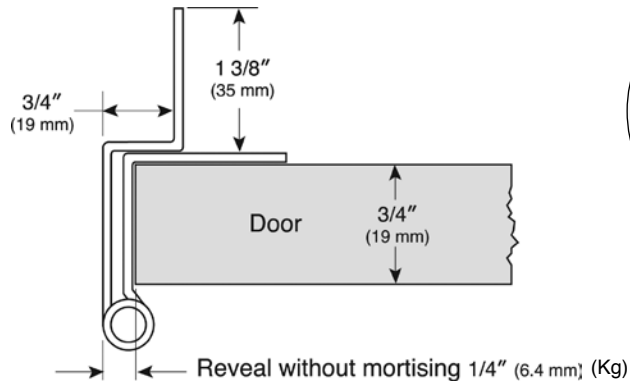

Hospital Tip



Catalog Number	Size Length of Frame Leaf Inches (mm)	Flat Head Wood Screws/ Per Pack	Pieces Per Pack	Packs Per Box	Packs Per Case	Case Weight Lbs. (Kg)
1592 & HT1592	2 3/4 (70)	16 - 8 x 5/8	2	5	50	40 (18)

CABINET AND WARDROBE HARDWARE

Cabinet Knobs

4482 – (ANSI B02131) – solid brass – polished and plated

- For cabinet doors and drawers up to ³/₄" (19 mm) thick
- Can be used on Bi-Fold doors
- ¹⁵/₁₆" (33.2 mm) projection



Catalog Number	Size Diameter		Flat Head Wood Screws/ Per Pack	Pieces Per Box	Pieces Per Case	Carton Weight	
	Inches	(mm)				Lbs.	(Kg)
4482	1 1/4	(32)	1– 8-32 x 1	25	100	11	(5)

Magnetic Cabinet Catches

CD42 – Plastic – tan

- Single screw mounting speeds installation
- Slotted screw hole in case allows for adjustment
- Floating magnet helps positive contact

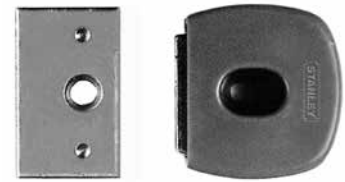

EDP Number	Size of Case		Size of Strike		Screws Per Piece	Packs Per Box	Packs Per Carton	Carton Weight	
	Inches	(mm)	Inches	(mm)				Lbs.	(Kg)
71-1030	1 1/8 x 1	(28.6 x 25.4)	1 1/8 x 7/8	(28.6 x 22.2)	1– 5 x 5/8 Flat Head 1– 6 x 1/2 Pan Head	5	100	7	(3.2)

CD46 – Aluminum – mill finish (AL)

- For a wide range of cabinet door applications
- Impregnated magnet is shutter resistant
- Slotted screw holes allow for adjustment
- Magnet and pole piece have floating action for positive contact



EDP Number	Size of Case		Size of Strike		Screws Per Piece	Packs Per Box	Packs Per Carton	Carton Weight	
	Inches	(mm)	Inches	(mm)				Lbs.	(Kg)
71-1075	2 x 1	(50.8 x 25.4)	1 1/8 x 7/8	(28.6 x 22.2)	2– 6 x 1/2 Pan Head 1– 6 x 1/2 Flat Head	5	100	8	(3.6)

CD41 } – Aluminum – mill finish (AL)
SP41 }

- Slotted screw holes allow for adjustment
- Floating magnet adjusts automatically for positive contact



Class Number	EDP Number	Size of Case		Size of Strike		Screws Per Piece	Packs Per Box	Packs Per Carton	Carton Weight	
		Inches	(mm)	Inches	(mm)				Lbs.	(Kg)
CD41	71-0300	2 x 1	(50.8 x 25.4)	1 1/8 x 7/8	(28.6 x 22.2)	2– 6 x 1/2 Pan Head 1– 5 x 5/8 Flat Head	5	100	12	(5.4)
SP41	81-0160	2 x 1	(50.8 x 25.4)	1 1/8 x 7/8	(28.6 x 22.2)	2– 6 x 1/2 Pan Head 1– 5 x 5/8 Flat Head	5	250	26	(11.8)

CABINET AND WARDROBE HARDWARE

Magnetic Cabinet Catches

CD45 } – Double catch – aluminum – mill finish (AL)
SP45 }

- For pairs of cabinet doors, or full size doors
- Floating magnets pivot to allow full contact with strikes
- Impregnated magnet withstand rugged use
- Slotted screw holes allow for adjustment



Class Number	EDP Number	Size of Case Inches (mm)	Size of Strike Inches (mm)	Screws Per Piece	Packs Per Box	Packs Per Carton	Carton Weight Lbs. (Kg)
CD45	80-5180	3 1/4 x 1 3/8 (82.6 x 35)	1 1/8 x 15/16 (28.6 x 17.5)	2– 5 x 5/8 Flat Head 1– 6 x 1/2 Pan Head	5	50	12 (5.4)
SP45	81-0190	3 1/4 x 1 3/8 (82.6 x 35)	1 1/8 x 15/16 (28.6 x 17.5)	2– 5 x 5/8 Flat Head 1– 6 x 1/2 Pan Head	20	100	22 (10)

Friction Cabinet Catches

CD37 – Steel – zinc coated (2C)

- Tempered spring steel insures positive engagement and smooth operation
- Self marking strike for quick installation

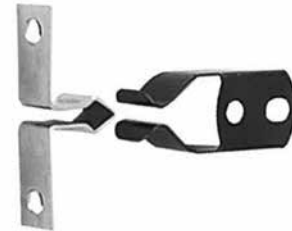

EDP Number	Catch Size Inches (mm)	Size of Strike Inches (mm)	Screws Per Piece	Packs Per Box	Packs Per Carton	Carton Weight Lbs. (Kg)
71-1400	1 3/8 x 9/16 (35 x 14.3)	1 3/8 x 3/8 (35 x 9.5)	4– 6 x 1/2 Pan Head	5	50	5 (2.3)

Spring Catches

CD34– Steel – zinc coated (2C)

- Jaws provide automatic adjustment for normal wood shrinkage
- Elongated holes allow for adjustment
- A ball head screw is provided in addition to the regular strike
- Self marking strike for quick installation



EDP Number	Catch Size Inches (mm)	Size of Strike Inches (mm)	Screws Per Piece	Packs Per Box	Packs Per Carton	Carton Weight Lbs. (Kg)
71-0100	1 7/16 x 3/4 (36.5 x 19)	1 3/8 x 3/8 (35 x 9.4)	4– 6 x 1/2 Pan Head	5	100	7 (3.2)

Roller Catches

CD35 } – Steel – zinc coated (2C)
SP35 }

- Elongated screw holes allow for adjustment
- Rollers absorb shock and minimize noise
- Self aligning arms work independently assuring easy and positive action
- Self marking strike for quick installation



Class Number	EDP Number	Size of Case Inches (mm)	Size of Strike Inches (mm)	Screws Per Piece	Packs Per Box	Packs Per Carton	Carton Weight Lbs. (Kg)
CD35	71-0130	1 1/4 x 3/4 (31.8 x 19)	1 3/8 x 3/8 (35 x 9.5)	4– 6 x 1/2 Flat Head	5	100	7 (3.2)
SP35	81-0130	1 1/4 x 3/4 (31.8 x 19)	1 3/8 x 3/8 (35 x 9.5)	4– 6 x 1/2 Flat Head	5	250	16 (7.3)

Magnetic Cabinet Touch Latch

CD47 – Plastic – brown

- Doors are opened by pushing inward to release contact with magnetic base
- Impregnated magnet withstands rugged use
- Projection from mounting surface 1 1/16" (17.5 mm)



EDP Number	Catch Size Inches (mm)	Size of Strike Inches (mm)	Screws Per Piece	Packs Per Box	Packs Per Carton	Carton Weight Lbs. (Kg)
80-5215	1 5/16 x 1 1/8 (33.3 x 28.6)	1 5/16 x 9/16 (33.3 x 14.3)	4– 5 x 5/8 Pan Head 1– 5 x 5/8 Flat Head	5	50	5 (2.3)

Bullet Catches

CD5357– Steel – bright brass coated (3)

- Catch is concealed when door is closed
- Easy to install



EDP Number	Bore Hole Inches (mm)	Packs Per Box	Packs Per Carton	Carton Weight Lbs. (Kg)
80-3850	3/8 (9.5)	5	100	8 (3.6)

CABINET AND WARDROBE HARDWARE

Ball Catches

80-3943 – Brass – bright finish (3)

- Small catch for cabinet or light duty residential doors
- Ball adjusts for door clearance and latch tension
- Diameter and depth of bore: $\frac{9}{16}$ " x 1" (14.3 x 25.4 mm)



EDP Number	Size of Face Plate		Size of Strike		Screws Per Piece	Packs Per Box	Packs Per Carton	Carton Weight	
	Inches	(mm)	Inches	(mm)				Lbs.	(Kg)
80-3943	$\frac{3}{4}$ x $1\frac{1}{2}$	(19 x 38)	$\frac{3}{4}$ x $1\frac{1}{2}$	(19 x 38)	4– 6 x $\frac{3}{4}$ Flat Head	5	60	10	(4.5)

CD80-3944– Brass – bright finish (3)

- Latches cabinet or light duty residential doors
- Ball adjusts for door clearance and latch tension
- Diameter and depth of bore: $1\frac{3}{16}$ " x $1\frac{5}{8}$ " (20.6 x 41.3 mm)



EDP Number	Size of Face Plate		Size of Strike		Screws Per Piece	Packs Per Box	Packs Per Carton	Carton Weight	
	Inches	(mm)	Inches	(mm)				Lbs.	(Kg)
80-3944	1 x $2\frac{1}{8}$	(25.4 x 54)	$1\frac{3}{8}$ x $2\frac{1}{8}$	(35 x 54)	4– 6 x $\frac{3}{4}$ Flat Head	5	50	10	(4.5)

Roller Latches

SP23 – Steel – bright brass plated (3)

- For use on doors having a minimum thickness of $1\frac{3}{8}$ "
- Spring loaded latch holds door closed
- Long-life nylon rollers operate silently with a push/pull action
- Tension is adjustable by turning roller
- Diameter and depth of bore: $\frac{7}{8}$ " x $2\frac{3}{8}$ " (22.2 x 60.3 mm)



EDP Number	Size of Face Plate		Size of Strike		Screws Per Piece	Packs Per Box	Packs Per Carton	Carton Weight	
	Inches	(mm)	Inches	(mm)				Lbs.	(Kg)
31-0360	$2\frac{1}{4}$ x 1	(57.2 x 25.4)	$2\frac{1}{4}$ x $\frac{9}{16}$	(57.2 x 14.3)	4– 8 x $\frac{5}{8}$ Flat Head	10	100	23	(10.4)

CD26 } – Steel – bright brass plated (3)
SP26 }

- For use on doors having a minimum thickness of $1\frac{1}{8}$ "
- Spring loaded latch holds door closed
- Long-life nylon rollers operate silently with a push/pull action
- Tension is adjustable by turning roller
- Diameter and depth of bore: $\frac{3}{4}$ " x $1\frac{1}{8}$ " (19 x 28.6 mm)



Class Number	EDP Number	Size of Face Plate		Size of Strike		Screws Per Piece	Packs Per Box	Packs Per Carton	Carton Weight	
		Inches	(mm)	Inches	(mm)				Lbs.	(Kg)
CD26	76-2260	$1\frac{3}{4}$ x $1\frac{5}{16}$	(44.5 x 23.8)	$1\frac{3}{4}$ x $1\frac{1}{4}$	(44.5 x 31.8)	3– 5 x $\frac{5}{8}$ Flat Head	10	100	9	(4)
SP26	81-0100	$1\frac{3}{4}$ x $1\frac{5}{16}$	(44.5 x 23.8)	$1\frac{3}{4}$ x $1\frac{1}{4}$	(44.5 x 31.8)	3– 5 x $\frac{5}{8}$ Flat Head	5	250	17	(7.7)

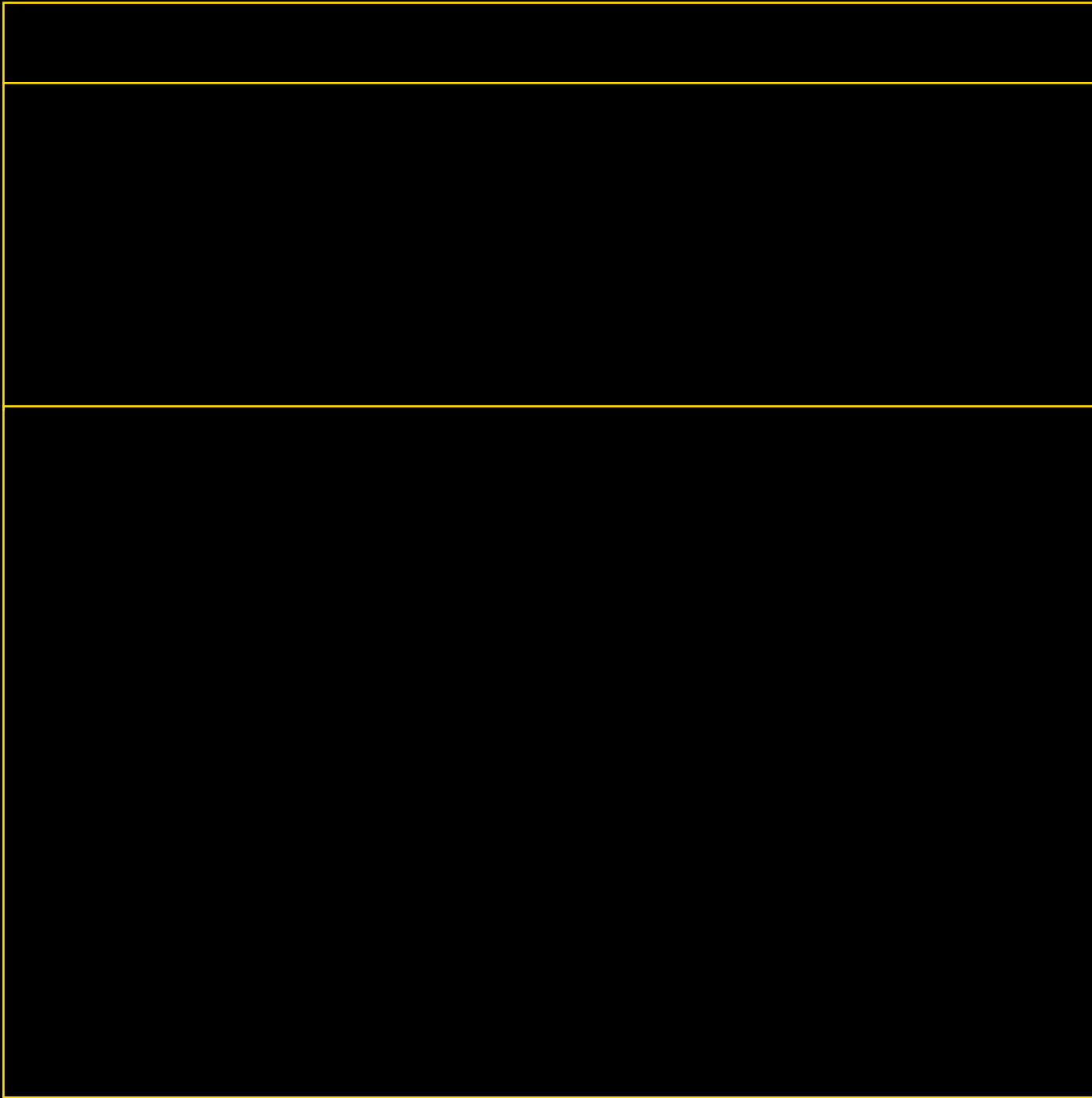

For more information on Stanley Security Solutions' products, services, and office locations visit our web site at www.stanleysecuritysolutions.com

Product information contained in this catalog has been compiled and presented with as much care and completeness as is reasonably possible. Errors or mistakes may be present, and in many cases, reliance has been placed on information supplied by other manufacturers which may be in error or which may be subject to changes or modifications by the manufacturer without notice and without obligation. Therefore, no guarantee can be made or should be assumed or implied with regards to product information contained in this catalog.



Stanley Security Solutions, Inc.

6161 E. 75th Street Indianapolis, Indiana 46250

www.stanleysecuritysolutions.com

© 2009 Stanley Security Solutions, Inc. and Stanley Logistics

10M 509FP
SAH015