



"We have found the Sauce Master™ efficient and easy to use. Making tomato juice is no longer a chore."
Sondra Hastreiter
Wisconsin

"I recently saw and was able to use your Sauce Master™. It was so terrific, I'd like to know where to purchase one."
H.E. Hohl
Pennsylvania

"Recently I was able to use model #1951, I was very impressed with the way this machine worked. I would like a list of stores in our area that handles this item. Please respond right away as my tomatoes will be ready in about one week."
Robert Hypes
Ohio

"I love the Sauce Master™ - it's great for applesauce and tomato puree...I will be straining my tomatoes and pumpkins soon."
Judy Fenske
Michigan

"Please ship an optional Grape Spiral to my in-laws. I bought them one of your Sauce Masters™, they said it works great!"
Tony Barker
Illinois

"...I've seen it work, and think it is great."
Pauline Fay
New Jersey

Parts Now Available Online!

Quick & Easy! Click & Buy!

Have parts shipped directly to you!
Most current info on all parts available!

consumer.norpro.com



Sauce Master™ Operating Instructions & Recipe Guide



1951

Everything you need to know to operate your Sauce Master™!

See page 3 for assembly.

See pages 4-5 for basic recipes and hints.

See pages 6-10 for delicious recipes!

See page 11 for accessories.

See pages 12-15 to order additional or replacement parts.



Parts Now Available Online!

QUICK & EASY! CLICK & BUY!

To order additional or replacement parts for your Sauce Master™, see chart on page 12 for part # and part cost. Visit us online to order parts at

consumer.norpro.com

Sorry, no part orders accepted by phone.

Prices subject to change without notice. All prices in U.S. Funds

Assembly Instructions

Before assembling your Sauce Master™ for the first time, wash and dry all components thoroughly. Coat the crankshaft and bushing of the body with a little vegetable oil.

1. Clamp the body firmly to your countertop or table.



2. Assemble the crankshaft, spring, and cup (Fig. A), making sure spring fits into open end of the cup.

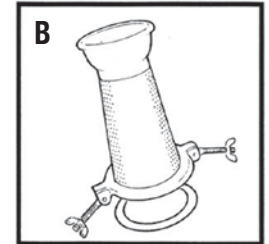

3. Place the thin flat rubber gasket in the inside collar of the screen assembly. (Fig. B)

4. Insert the square end of the crankshaft assembly into the square hole inside the spiral assembly.

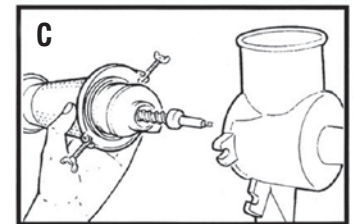

5. Now fit the screen, spiral, and shaft assembly into the body, inserting the threaded end of the shaft through the bushing in the body. (Fig. C)

6. Place the screen screws into the slotted lugs on the body and begin to tighten the wing nuts. Fit the guard around screen assembly, slip the slot on guard over screen screws, completely tighten wingnuts until the screen assembly is attached securely to the body. (Fig. D)

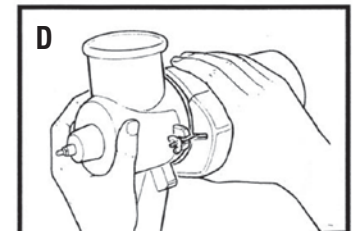

7. Attach the handle onto the threaded shaft protruding from the back of the body and tighten the handle securely to the shaft by using the wing nut.

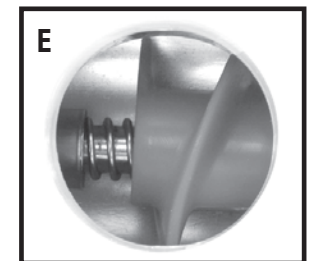

8. Insert the hopper into the top opening of the body until snug.

9. View looking through hopper opening when assembled correctly. (Fig. E)

Basic Operations & Hints

Wash your fruit or vegetables before you begin processing with the Sauce Master™. You will need two bowls, one to collect the puree, and one for the seeds, stems, and skins. Since the Sauce Master™ works so quickly and with so little waste, a large bowl under the tray to catch the puree and a small one for the waste works best!

DO NOT OPERATE THE SAUCE MASTER™ EMPTY.

The juice from the fruits and vegetables act as a lubricant for the mechanism, and reduces wear on the components. Cranking the handle before food is placed in the strainer can cause damage to the spiral.

Cut fruit or vegetables into small pieces. Pieces should be small enough to fit into the opening at the base of the hopper. Remove all large pits and stems. The strainer will remove peels, cores, seeds and small stems.

Do not force foods into the spiral. Guide them in with the large end of the plunger. This will help eliminate jamming and squirting.

You may need to occasionally remove the squirt guard tray and scrape pulp from the screen of the Sauce Master™, depending on the type of food you are processing. A rubber spatula works best for this.

The squirt guard tray may also need to be removed when straining dry ingredients such as beans and potatoes, as they tend to get stuck between the screen and the guard.

To get the most out of your fruits and vegetables; you can re-strain the skins from the waste bowl a second time.

If you are straining foods to can, freeze or dehydrate, consult a good food guide to home preserving. Proper methods are important!

TROUBLESHOOTING

If the handle becomes difficult to turn while processing, turn a complete turn counter clockwise, then forward again slowly. This will help clear any obstructions and allow the strainer to operate normally. If the jam does not clear, you will need to disassemble and clean out the jam.

TIP: It may also help by slightly loosening the wing nuts that attach the screen. Over-tightened wing nuts can put too much pressure on the spiral, making it harder to turn.

If the juice is backing up into the hopper and not going through the screen, the screen may be clogged up with pulp. Simply remove the squirt guard tray and scrape the pulp off the outside of the screen with a rubber spatula.

When processing juicy fruits like tomatoes, there may be slight leaking from the handle. If there is excessive leaking, check to make sure the clear silicone gasket (1951-17) is in place. Replacing the gasket periodically may be necessary.

Replacement parts are available to order if needed.



Basic Operations & Recipes

Tomato Puree

Quarter ripe tomatoes and fill the Sauce Master's™ spacious hopper. No need to peel or core, the Sauce Master™ does it all for you! Then just push the plunger as you turn the handle in a clockwise direction. In moments thick, tangy puree will be pouring from the tray to quickly fill your bowl. Meanwhile, dry skins, seeds, and cores fall out the end of the screen into a second bowl with absolutely no juice wasted. In just minutes, you'll have gallons of puree ready to put up as velvety-smooth tomato juice. Or simmer it with your favorite seasonings for the most flavorful spaghetti sauce you've ever tasted! For an even thicker textured tomato sauce with seeds, but no skins, try using the optional pumpkin screen (available separately) in place of the standard screen.

Applesauce

Simply cut apples into quarters and simmer in boiling water until tender. No need to peel or core! Drain and let cool slightly. Fill the hopper and push the plunger while you crank in a clockwise direction. If jamming occurs, apples are too hard and need to be cooked a little longer. For a thicker, chunky-style apple sauce, use the optional pumpkin screen (available separately) in place of the standard screen.

Berry Juice

By using the optional berry screen (available separately), you can remove even the tiny seeds found in blueberries, blackberries, raspberries, and currants. Hull and juice gallons of strawberries fast for jelly or syrup. Add some crushed whole berries for delicious jam!

Pumpkin, Squash, or Potato Purees

The optional pumpkin screen (available separately) creates the smoothest pumpkin, squash, or sweet potato pie fillings or mashed Irish potatoes (no peeling needed). Before processing, simply dice into 1 inch squares and steam or bake until tender. Allow to cool.

Baby Food

With today's concern over additives and excess sugar in our children's food, the Sauce Master™ is an ideal alternative to store bought baby food. It can easily puree fresh vegetables, fruits, or cooked meats and poultry. And by using the three different sized screens, you can tailor the texture of the food to meet your baby's needs!

Grape Juice

The optional grape spiral (available separately) is specially designed to let you make gallons of delicious grape juice! Wash the grapes and remove from the stem. Assemble your Sauce Master™ with the standard screen and the optional grape spiral in place of the standard spiral.



Recipes

Your Sauce Master™ can help you make many other delicious treats! Simply spread out a thin layer of any fruit puree on wax paper and dehydrate for terrific fruit roll-ups! You can puree cranberries for fresh cranberry sauce, or prunes for authentic Hungarian Lekvar. Steamed carrots and zucchini run through the Sauce Master™ with the pumpkin screen (available separately) to make wonderful cakes and breads. Or try cooked pinto or kidney beans for the beginning of Mexican refried beans.



Using your tomato puree!

Basic Tomato Sauce

1 onion, finely chopped	1 cup (.23 L) beef broth
2 cloves garlic, minced	1/2 tsp. (2.5 g) oregano
2 Tbsp. (15 g) butter	1/2 tsp. (2.5 g) basil
1 Tbsp. (15 ml) olive oil	1/2 tsp. (2.5 g) sugar
1-1/2 cups (.35 L) tomato puree	salt and pepper to taste

Sauté onion and garlic in butter and oil until soft. Add tomato puree, broth, herbs, and spices. Boil until reduced to 2 cups. Serve over vegetables or pasta. May be refrigerated or frozen for later use.

Italian Spaghetti Sauce

2 Tbsp. (30 ml) olive oil	1-1/2 tsp. (7.5 g) salt
1 onion, chopped	1 Tbsp. (15 g) basil
2 cloves garlic, minced	1 tsp. (5 g) sugar
2 lbs. (.9 kg) ground beef	1/2 tsp. (2.5 g) ground pepper
8 cups (1.9 kg) tomato puree	

Heat oil in large sauce pan. Cook onion and garlic for 3 minutes. Add meat and continue cooking until meat begins to brown. Stir in tomato puree and remaining ingredients. Simmer uncovered for about 45 minutes or until thickened. Serve with cooked pasta.

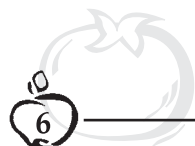

Recipes

Chicken Gacciatore

1/2 cup (113 g) flour	1 onion, finely chopped
1 tsp. (5 g) salt	1 carrot, chopped
1 tsp. (5 g) paprika	1 stalk celery, chopped
1/4 cup (60 ml) olive oil	1/8 cup (30 g) parsley, chopped
8 chicken thighs	1 bay leaf
2 garlic cloves, minced	2 cups (.454 L) tomato puree
	1/4 cup (60 ml) dry white wine

Dredge chicken in flour mixed with salt and paprika. Heat oil and brown chicken on all sides. Remove from heat. Sauté garlic, onion, carrot, and celery until soft. Add parsley, bay leaf and tomato puree. Bring to boil. Add chicken and wine. Reduce heat and simmer. Cover for 30 minutes. Serve with pasta. Makes 4 servings.

Cioppino for 6

1/2 cup (118 ml) vegetable oil	1 bay leaf
1/2 cup (118 ml) each chopped onions and scallions	salt and pepper to taste
1 green pepper, chopped	2 lbs. (.91 kg) firm white fish cut in large pieces
2 garlic cloves, chopped	1 lb. (.45 kg) fresh crab cut in pieces
3 cups (.71 L) tomato puree	1 lb (.45 kg) shrimp, shelled
2 cups (.47 L) red wine	1 pint (.47 L) clams or mussels

In deep heavy saucepan heat oil. Add onions, scallions, green pepper, and garlic and cook until soft. Add tomato puree and red wine. Add bay leaf and salt and pepper to taste. Bring to a boil and simmer for 10 minutes. Add fish, lobster or crab, and shrimp. Cook 15 minutes. Add clams or mussels and cook for 5 minutes. Serve very hot in deep bowls with plenty of French bread and red wine.

Molded Tomato Salad for 6

1 8 oz (225 g) package cream cheese	1 tsp. (5 g) salt
1-1/2 cups (340 g) mayonnaise (not salad dressing)	Dash of Tabasco
1 onion, grated	1-1/2 packages plain gelatin
Juice of 1/2 lemon	3 cups (.71 L) tomato puree
	1 cup (227 g) finely chopped celery

Soften cream cheese and beat in mayonnaise, onion, and seasonings. Soften gelatin in 1/4 cup (60 ml) tomato puree. Dissolve by placing cup in hot water until gelatin is liquid. Stir into remaining tomato puree and combine with cheese mixture. Fold in celery. Turn into 6 cups (1.42 L) ring mold. Freeze. Remove to refrigerator 1 hour before serving. Turn out and garnish with cucumbers and greens. Serve with tuna or chicken salad.



Recipes

Vegetable Juice

For tomato juice just add water and your favorite seasoning to tomato puree-or try this!

8 qt. (7.57 L) ripe tomatoes	1 cup (227 g) carrots, finely chopped
8 stalks of celery	1 cup (227 g) green pepper, finely chopped
3 small onion, finely chopped	1 Tbsp. (15 g) salt
1 leek, white part finely chopped	1/2 tsp. (2.5 g) ground allspice
1/4 cup (57 g) parsley	1 Tbsp. (15 ml) Worcestershire sauce
Juice of one lemon	fresh ground pepper to taste

Wash tomatoes and cut into quarters. Put tomatoes, celery, onion, leek, parsley, lemon juice, carrot and green pepper into large non-aluminum cooking pot. Cook over medium heat for 30 minutes until vegetables are soft. Put mixture through the Sauce Master™. Season with salt, allspice, Worcestershire sauce and pepper. Chill and serve. Yields approximately 6 quarts.

Spicy Applesauce

8 lbs. (3.63 kg) apples - quartered	1/4 cup (60 ml) honey
12 whole cloves	ground nutmeg
1 cinnamon stick	

Place apples in a large kettle with a small amount of water, cloves and cinnamon stick. Cover and steam until tender over medium heat, about 15 minutes. Remove the cloves and cinnamon and put the mixture through the Sauce Master™. Add remaining ingredients to taste.

Danish Apple Cake

2 cups (.454 g) finely crushed zwieback crumbs	
1 cup (227 g) melted butter	1/2 tsp. (2.5 g) ground cardamon
3/4 cup (150 g) sugar	3 cups (680 g) unsweetened applesauce
1-1/2 tsp. (7.5 g) cinnamon	whipped cream

Preheat oven to 350° F/ 177° C. Mix crumbs and melted butter. In a separate bowl mix sugar and spices. Put thin layer of crumbs on bottom of buttered 9" tube pan. Sprinkle with sugar mixture. Add thin layer of applesauce. Repeat layers until ingredients are used up. Bake for 1 hour. Cool and turn out. Frost with whipped cream.

Recipes

Using your pumpkin puree!

Pumpkin-Apple Pie

Pastry for a single 10 inch pie crust	1-1/2 cups (.36 L) light cream
2 medium size apples	1 tsp. (2.5g) ground cinnamon
1 tsp. (5g) sweet butter	1/2 tsp. (2.5g) ground nutmeg
2 cups (455g) pumpkin puree	1/4 tsp. (1.25g) ground cloves
2 large eggs	1/4 tsp. (1.25g) ground ginger
1 cup (230g) brown sugar	

Preheat oven to 425°F/220°C. Grease a 10 inch pie plate. Roll out the pastry and fit it into the pie plate. Trim and flute the edges. Refrigerate. Peel, core, and slice the apples into 1/4 inch pieces. Place in a skillet with 1 tsp. butter, cover and cook for 5 minutes. Remove from the heat and drain. Place the remaining ingredients in a medium size mixing bowl. Beat together until smooth. Arrange the apple slices in the bottom of the chilled pastry shell and pour over the pumpkin mixture. Bake in oven for 15 minutes. Reduce the heat to 375°F/190°C and continue baking for 35-40 minutes, or until a knife inserted into the center comes out clean. Allow to cool before serving.

Pumpkin Cheesecake

8 oz (230g) cream cheese
1 cup (230g) cottage cheese
2 eggs
1/2 cup (115g) pumpkin puree
1/2 tsp. (2.5g) ground mace
1 cup (230g) sugar, divided
1 tsp. (5ml) vanilla
1 Tbsp. (15g) grated lemon rind
1-1/2 cups (.35kg) graham cracker crumbs
1/4 cup (60g) butter, melted

Beat together the cheeses. Beat in eggs. Add pumpkin puree, mace, 1/2 cup sugar, vanilla, and lemon rind. Mix well. Mix together the cracker crumbs, butter and 1/2 cup sugar. Press all but 1/4 cup of crumb mixture onto bottom and sides of 8" springform pan. Pour pumpkin mixture into crust. Sprinkle with remaining crumbs. Bake at 325° F/165° C for 45 minutes. Turn off heat and open oven door. Leave cake in oven for 1 hour. Remove and cool. Refrigerate for several hours before cutting.

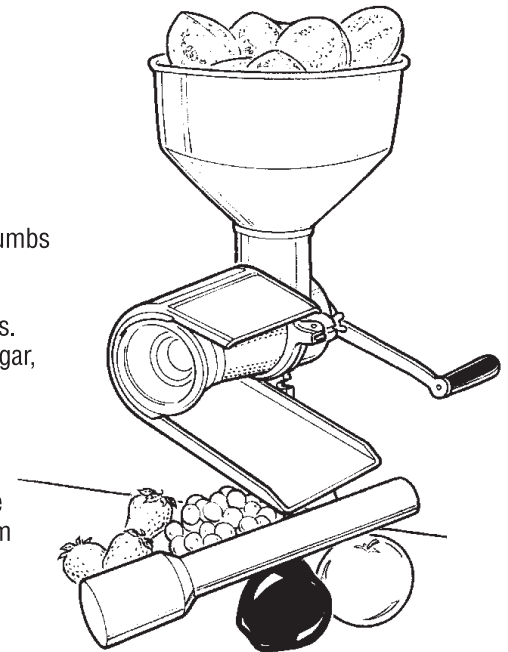

Carrot Cake

3 C (690g) carrots, pureed	1/2 tsp. (2.5g) salt
4 eggs	2 tsp. (2.5g) baking powder
1-1/4 C (300ml) vegetable oil	1-1/4 C (460g) walnuts, chopped
2 C (460g) sugar	1 tsp. (5ml) vanilla
2 C (460g) flour	1/2 tsp. (2.5g) ground ginger

Preheat oven to 350°F/177°C. In large bowl mix together carrot puree and eggs. Add oil and blend. Gradually stir in sugar, flour, salt and baking powder mixing well. Add nuts, vanilla and ginger. Combine and scoop into greased loaf pan. Bake for 1-1/2 hours until cake sets. Test by inserting toothpick or knife into the center of cake, when you pull it out clean, your cake is done. Remove from oven and allow to cool before icing.

Recipes Using a Salsa Screen Insert

Fresh Raw Salsa

4 medium tomatoes, cored and quartered	1/2 cup cilantro, chopped
1/2 red onion, quartered	Salt and Pepper to taste
1 red bell pepper, stems ribs, seeds removed	1 lime, juiced
1 jalapeño, stems, ribs, seeds removed	

Optional: Parsley or chilli powder.

Because the holes in the salsa screen are large, all stems and seeds to peppers must be removed first. Cut all of the vegetables small enough to fit into the Saucer Master™.

Alternate putting tomatoes, onion, pepper and jalapeño into hopper. This will help mix everything together. Put mixture in a bowl and add chopped cilantro, lime juice, salt and pepper. Stir together and refrigerate for 1 to 2 hours for the best results. If too watery, drain excess liquid.

Serve with tortilla chips, tacos, burritos and tostadas.

Make approximately 4 cups.

Cleaning and Storage

Disassemble the Norpro Sauce Master™ and hand wash all parts in hot, soapy water. Do not put in the dishwasher. Rinse and dry thoroughly right after use. You may need to use a stiff bristled brush to clean the screens.

The white plastic parts may become discolored after straining cooked foods, such as tomatoes and berries.

Applying a drop of vegetable oil to the clear silicone gasket (part 1951-17) is recommended to keep it from drying and becoming brittle.

Spray cooking oil on the screen assembly prior to storing to prevent screen from rusting and eventual difficulty in operation. We recommend you keep the original box to store the Sauce Master™ when it's not being used.

Optional Screens & Spiral

Available to Purchase Separately



Attachments that can be purchased separately:
(see Parts List page for price and ordering information).

#1953 is the Berry Screen. It is best used for removing seeds from blackberries, blueberries, raspberries, and strawberries. Great for making jams, jellies, pie filling and baby food.

#1954 is the Pumpkin Screen. It can be used to make a thicker sauce because the holes are larger. A chunkier apple sauce, a chunkier tomato sauce and of course potatoes, pumpkin, squash and zucchini for baking bread, pies and baby food.

#1954SS is the Salsa Screen. This is our coarse screen. It has holes that are 1/4". Best used for making your favorite salsa. Can be used by putting onions, peppers and tomatoes through all at the same time.

#1955 is the Grape Spiral. This spiral is 1" shorter than the standard spiral. It is specially designed to let you make grape juice using the Standard Screen.

Attachments that come with the original purchase:

#1951-12 is the Standard Screen. It can be used to puree apricots, tomatoes, apples, peaches, plums, pears, prunes, and just about any fruit. Great for beans, chicken and peas.

#1951-8 is the Standard Spiral. This spiral does almost everything. It is used with all the screens listed above.

Clean and dry after use.

Parts Now Available Online!

QUICK & EASY! CLICK & BUY!

To order additional or replacement parts for your Sauce Master™, see chart below for part # and part cost. Visit us online to order parts at

consumer.norpro.com

Sorry, no part orders accepted by phone.

Prices subject to change without notice. All prices in U.S. Funds

Parts List

Part #	Description	Cost
1951-1	Body including clamp assembly	\$19.00
1951-2	Hopper (funnel)	12.00
1951-3	Plunger	5.00
1951-4	Handle wing nut	2.00
1951-5	Handle	7.00
1951-6	Crank shaft	5.00
1951-7	Cup	2.00
1951-8	Spiral-Standard 6.75"	10.00
1951-9	Wing nut (for screen)	2.00
1951-11	Squirt Guard Tray	12.00
1951-12	Screen - standard	19.00
1951-14	Thin flat gasket	3.00
1951-15	Spring	3.00
1951-17	Clear silicone gasket	2.00
1953	Fine 3/64" mesh berry screen assembly	19.00
1954	Coarse 1/8" mesh pumpkin screen assembly	19.00
1954SS	Salsa Screen	19.00
1955	Grape Spiral 5.5"	10.00

Shipping and handling \$4.00 within the continental U.S.A. \$10.00 within Canada. All other countries please contact: sales@norpro.com for current shipping rates.

See diagrams on page 13 for reference to machine parts.

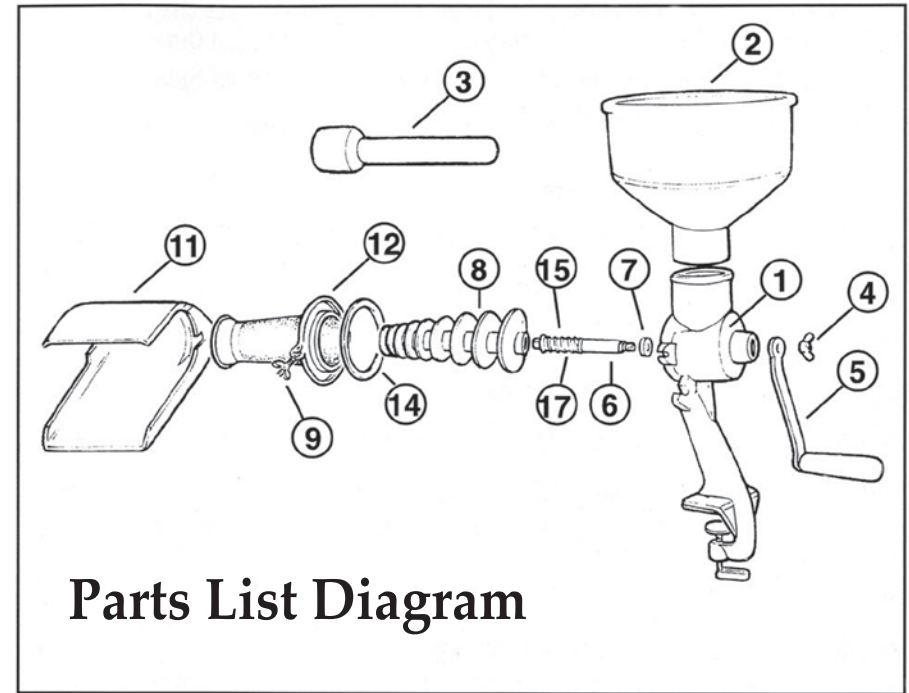

Parts List Diagram

SAVE TIME! ORDER ONLINE!
consumer.norpro.com

Have parts shipped directly to you.
 Most current info on all parts available.

Parts Now Available Online! Quick & Easy! Click & Buy!

Have parts shipped directly to you!
Most current info on all parts available!

consumer.norpro.com

If unable to order online, please use our order form below.
Mail check, money order or provide credit card number,
including expiration date and CVV code to:

NORPRO
2215 Merrill Creek Parkway
Everett, WA 98203-5899

For all other countries, we accept only Visa or Mastercard.
(no checks or money orders)

Parts List Order Form

Please send me part(s) for **Sauce Master™**

Part letter \$
QUANTITY

Part letter \$
QUANTITY

Shipping and Handling USA \$4.00
Shipping and Handling Canada \$10.00

All other countries contact us for current rates: \$

Total \$

We accept Visa or Mastercard

Credit Card Type: Visa Mastercard

Credit Card Number:

Expiration Date:

CVV code (3 digit security code):

Signature: _____

Print Name: _____

Address: _____

Please send me part(s) for **Sauce Master™**

Part letter \$
QUANTITY

Part letter \$
QUANTITY

Shipping and Handling USA \$4.00
Shipping and Handling Canada \$10.00

All other countries contact us for current rates: \$

Total \$

We accept Visa or Mastercard

Credit Card Type: Visa Mastercard

Credit Card Number:

Expiration Date:

CVV code (3 digit security code):

Signature: _____

Print Name: _____

Address: _____

Please send me part(s) for **Sauce Master™**

Part letter \$
QUANTITY

Part letter \$
QUANTITY

Shipping and Handling USA \$4.00
Shipping and Handling Canada \$10.00

All other countries contact us for current rates: \$

Total \$

We accept Visa or Mastercard

Credit Card Type: Visa Mastercard

Credit Card Number:

Expiration Date:

CVV code (3 digit security code):

Signature: _____

Print Name: _____

Address: _____