

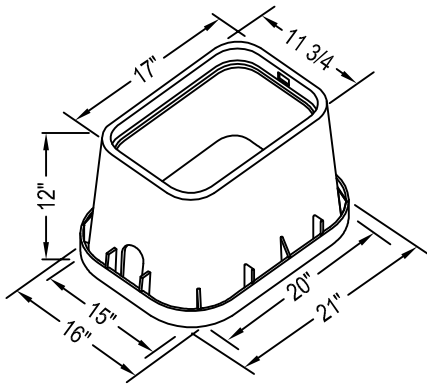

NDS, INC.  
 851 NORTH HARVARD AVE.  
 LINDSAY, CA 93247  
 TOLL FREE: 1-800-726-1994  
 PHONE: (559) 562-9888  
 FAX: (559) 562-4488  
 www.ndspro.com

PART NUMBER	DESCRIPTION - MARKING	COLOR (BOX/COVER)	PALLET QTY.	WEIGHT EA.	PRODUCT CLASS
<b>BOX &amp; COVER</b>					
113BC	14"X19" BOX, OVERLAPPING COVER - ICV	BLACK/GREEN	78	8.00	20ND
113BC SAND	14"X19" BOX, OVERLAPPING COVER - ICV	SAND/SAND	78	8.00	20ND
115	14"X19"X6" BOX, EXTENSION, OVERLAPPING COVER - ICV	BLACK/GREEN	49	8.00	20ND



BOX

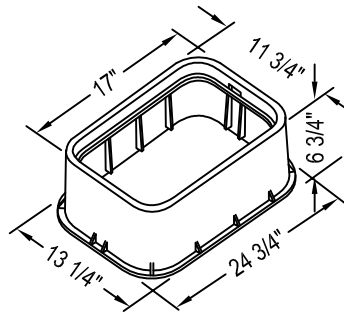

EXTENTION/RISER

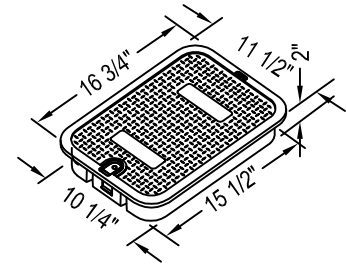

COVER

PERSPECTIVE VIEWS

NOTES:

1. INSTALLATION TO BE COMPLETED IN ACCORDANCE WITH MANUFACTURER'S SPECIFICATIONS.
2. DO NOT SCALE DRAWING.
3. THIS DRAWING IS INTENDED FOR USE BY ARCHITECTS, ENGINEERS, CONTRACTORS, CONSULTANTS AND DESIGN PROFESSIONALS FOR PLANNING PURPOSES ONLY.
4. ALL INFORMATION CONTAINED HEREIN WAS CURRENT AT THE TIME OF DEVELOPMENT BUT MUST BE REVIEWED AND APPROVED BY THE PRODUCT MANUFACTURER TO BE CONSIDERED ACCURATE.

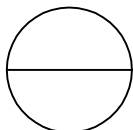

**PRO SERIES VALVE BOXES**

14" X 19" RECTANGULAR - 113BC