

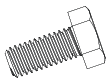

Instructions for Ranch Series 300lb Hopper

Thank you for your purchase of a Moultrie Ranch Series 300lb Hopper. Please read this sheet before operating the unit. If you should have any questions about this product or any other Moultrie product, please contact us using the information on the back of this sheet. Allow us to better serve you by activating your 1-year warranty online at <http://www.moultriefeeders.com/warranty>.



Short M6 Bolt
M6 x 1 x 14
Qty. 16



M6 Lock Nut
M6 x 1
Qty. 16

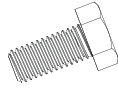

Short M8 Bolt
M8 x 1.25 x 14
Qty. 8

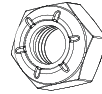

M8 Lock Nut
M8 x 1.25
Qty. 16

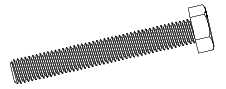

Long M8 Bolt
M8 x 1.25 x 50
Qty. 8

A ASSEMBLE THE HOPPER

1 Remove all hardware from packaging.

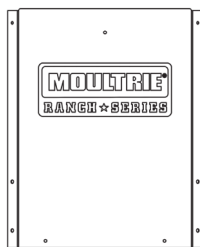

Face Panel (x2)

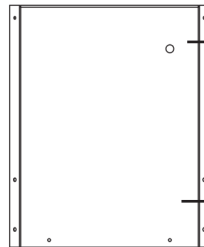

Side Panel (x2)

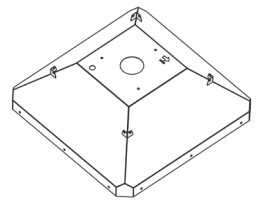

Cone (x1)

2 Gather all 4 hopper panels and the hopper cone.

Place the cone on its side, with the front arrow pointing either **Left** or **Right**. Attach both face panels to the cone using (4) M6 Short Bolts and (4) M6 Lock Nut. *Hand tighten only.*

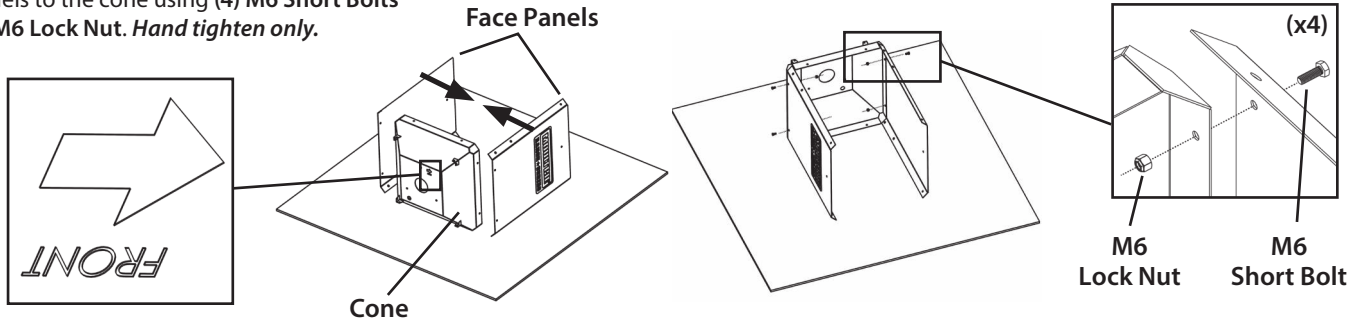

Place a face panel on top of the cone and overlapping the side panels. Align the bolt holes in the cone with the (2) lower holes in the face panel. Secure using (2) Short M6 Bolts and (2) M6 Lock Nuts. *Hand tighten only.*

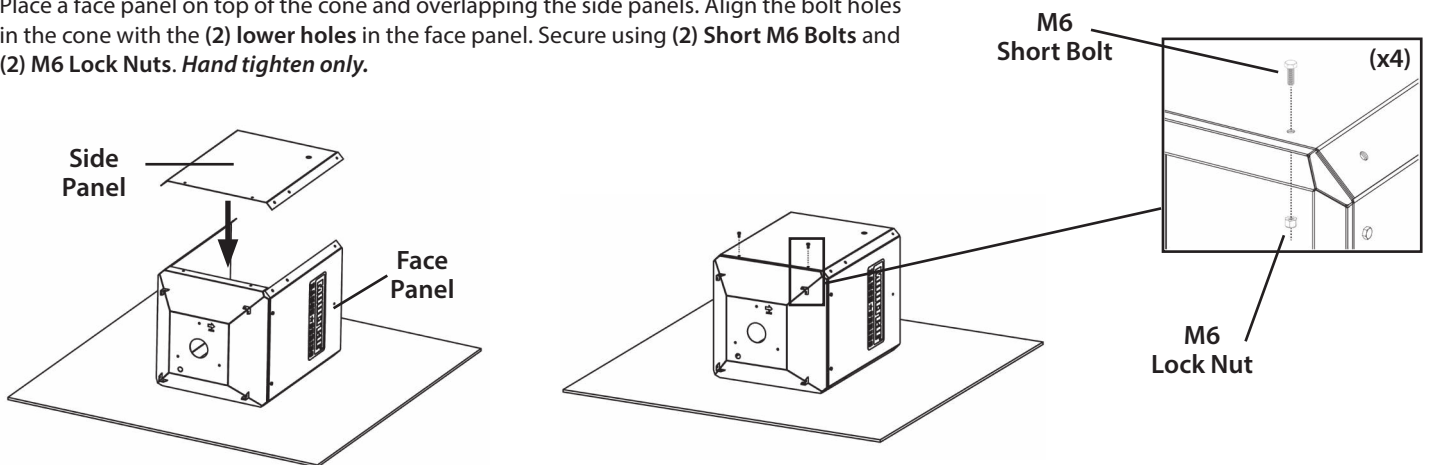

Flip the hopper over and install the remaining face panel following the same procedure above.

OPTIONAL: (2) Solar Panel Mounts are included with the kit. Install during this step if you choose to use them. (Not included with Gravity Kit)

Stand the hopper upright with the cone flat on the floor. Align the bolt holes in the top (4) corners. Secure with (4) Short M6 Bolts and (4) M6 Lock Nuts. *Hand tighten only.*

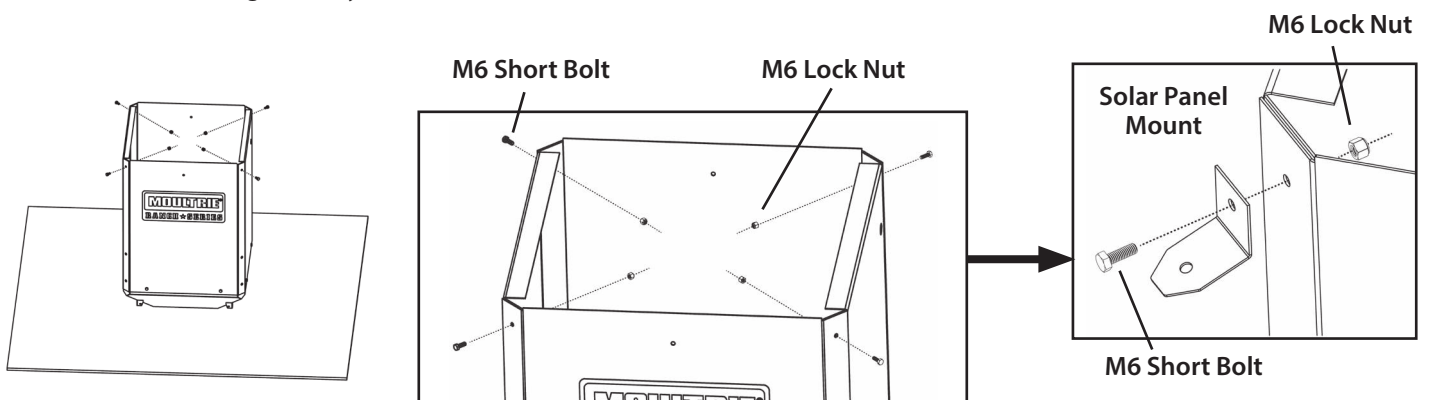

3

Place the (4) **leg brackets** against the corner bracket mounting holes as shown, align the holes and insert (2) **short M8 bolts** from the outside of each leg bracket into the hopper. Secure with a hand-tight **M8 lock nut** on each bolt (8).

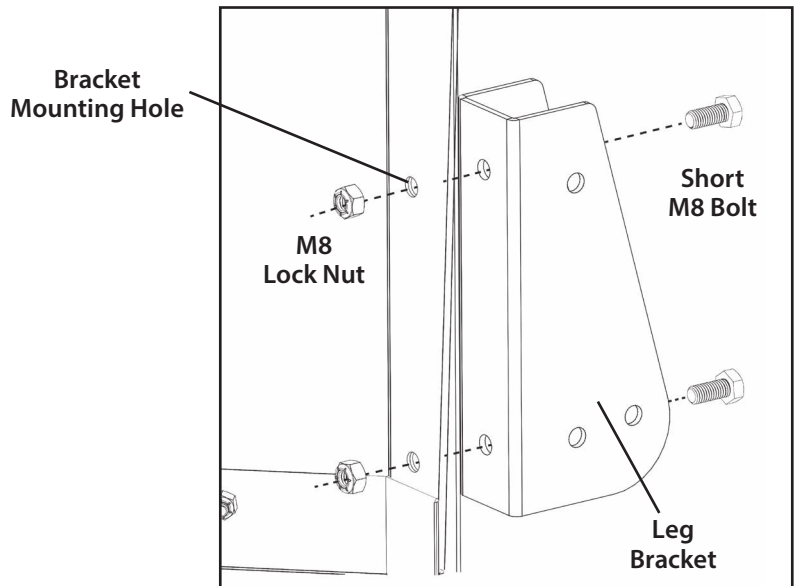
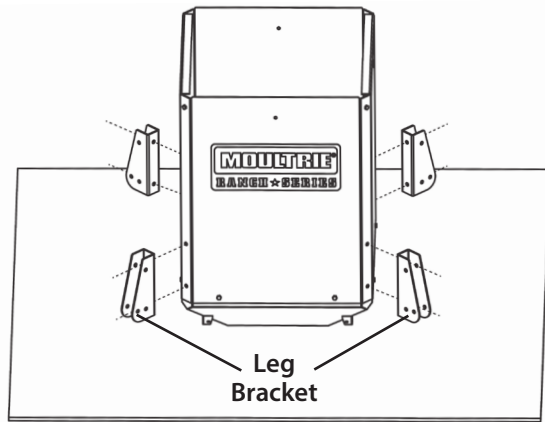

Leg Bracket (x4)

4

Go back and tighten all previously installed bolts. **M6 bolts** will require a 10mm wrench, **M8 bolts** (leg bracket) will require a 13mm wrench.

Note: Do not overtighten.

5

Install the **Face Panel Tabs** (2) to both the face panels, using a short **M6 bolt** and a **lock nut**. Tighten with a 10mm wrench. The "lip" should point upwards to create a hanger for the lid handle while filling feeder.

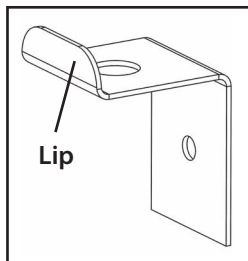

Face Panel Tab (x2)

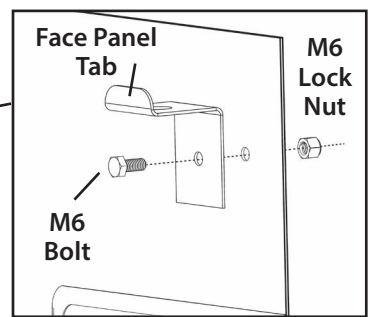
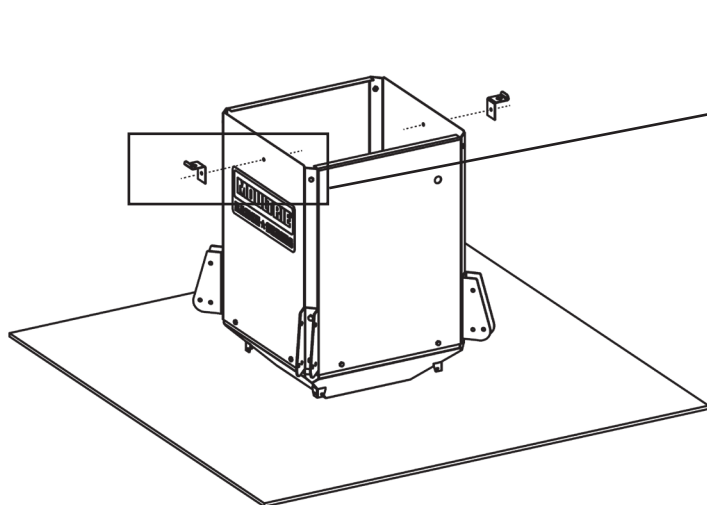

Face Panel (x2)

B

ASSEMBLE & INSTALL THE LEGS

1

Collect all 4 **Top-Leg** sections. Insert each section into a leg bracket. Set the leg angle to either 0° or 15° (*15° recommended for most installations*). Secure each with (2) **long M8 bolts** and (2) **M8 lock nuts**. Tighten using a 13mm wrench.



Top Leg (x4)

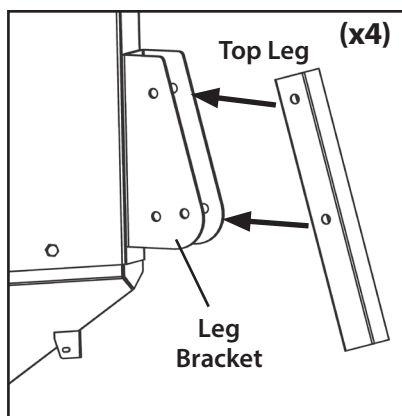

15 Degree Leg Orientation

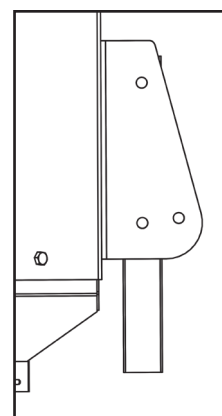
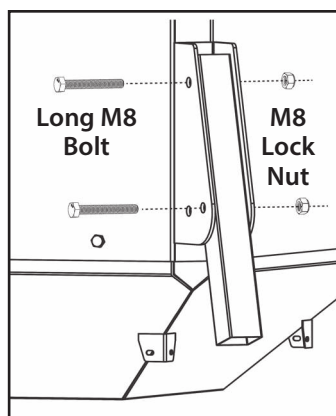

0 Degrees

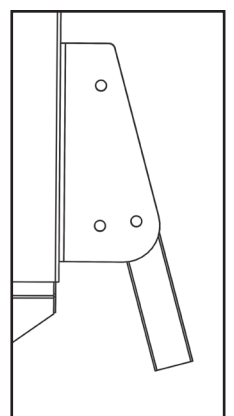

15 Degrees (recommended)

2

Insert the remaining leg sections into the (4) top-leg sections. Tap firmly on the end of the legs when joining leg sections; this will help to keep them locked together.

Leg Section



Top Leg

Leg Sections

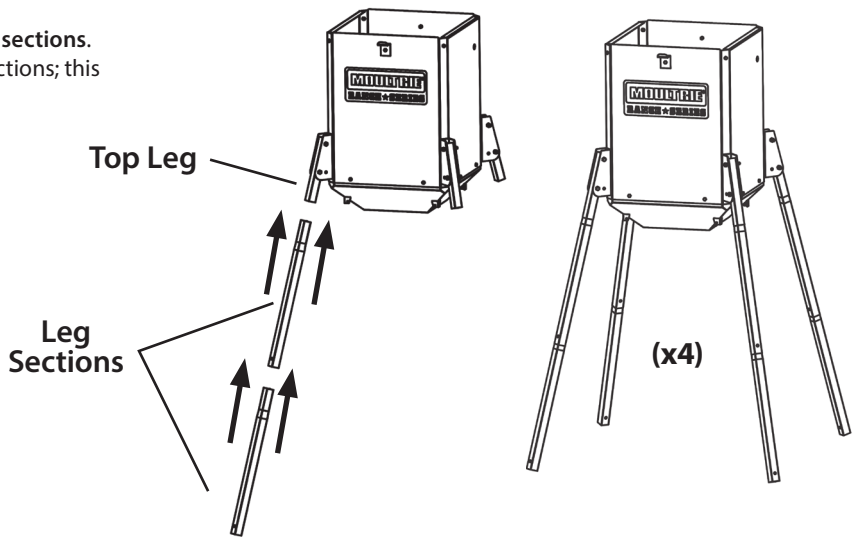

C INSTALL FEEDER KIT ONTO HOPPER

See additional feeder kit instructions for installation.

D INSTALL INTERNAL FUNNEL

After installing your feeder kit onto your hopper, insert the **internal funnel** into the **hopper**, letting the self-alignment ring lock it into place at the bottom of the hopper cone.

NOTE: Make sure internal funnel is fully seated at hopper exit, and placed at the very bottom of the hopper. Funnel alignment is critical to proper feeder operation.

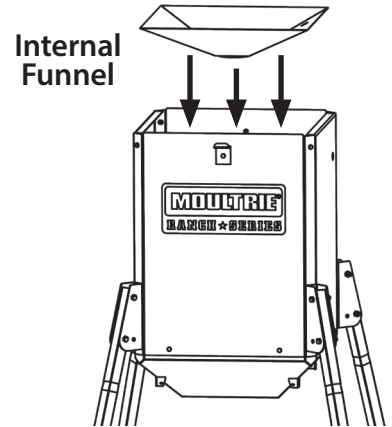

Internal Funnel

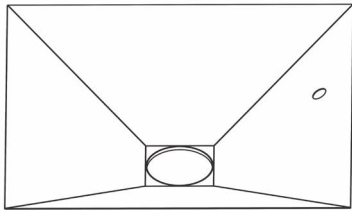

Internal Funnel

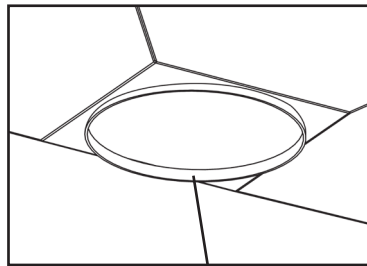

Self-Alignment Ring

E ASSEMBLE & INSTALL THE LID

1 Install the **Lid Tabs (2)** to the mounting holes on the lid by inserting a short M6 bolt from the **INSIDE** of the lid and securing with a lock nut tightened with a 10mm wrench. These will enable you to lock your feeder lid using most standard locks.

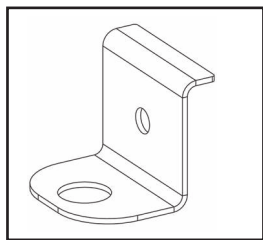

Lid Tab (x2)

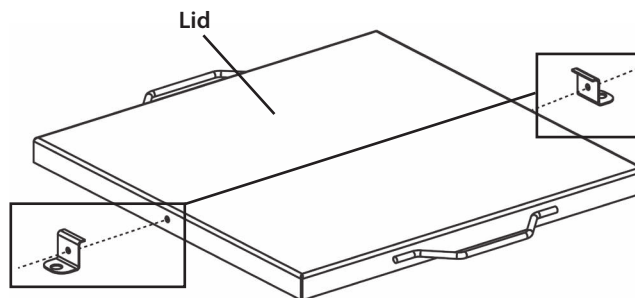

Lid

Lock Nut

Lid Tab

M6 Bolt

(x2)**2**

Place the lid assembly on top of the feeder with the tabs aligned. The handles should be on the sides of the feeder.

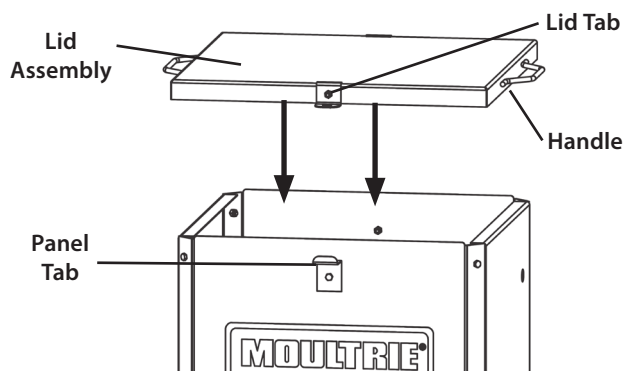

Lid Assembly

Lid Tab

Handle

Panel Tab

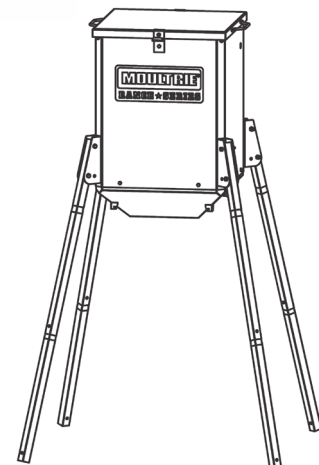

MOULTRIE®

Our Service Department will gladly answer any questions you have.
www.moultriefeeders.com/support

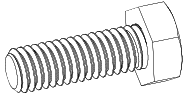

Instructions for Ranch Series Broadcast Feeder Kit

Thank you for your purchase of a Moultrie Ranch Series Broadcast Feeder Kit. Please read this sheet before operating the unit. If you should have any questions about this product or any other Moultrie product, please contact us using the information on the back of this sheet. Allow us to better serve you by activating your 1-year warranty online at <http://www.moultriefeeders.com/warranty>.



Bolt
M6 x 1 x 18
Qty. 5



Flat Washer
M6
Qty. 8*

* 3 only required if mounting to a hopper other than Moultrie Ranch Series



Wingnut
M6 x 1
Qty. 2

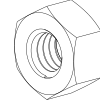

Hex Nut
M6 x 1
Qty. 3**

** only required if mounting to a hopper other than Moultrie Ranch Series

A ASSEMBLE THE FEEDER KIT

1 Remove all hardware from packaging.

2 Insert the vertical supports into the guides on the side of the feeder kit.

ONE-HOLE SUPPORT: Insert one-hole support into the left-hand side support guide with tab facing away from the spin plate.

TWO-HOLE SUPPORT: Insert two-hole support into the right-hand side support guide with tab facing towards the spin plate.

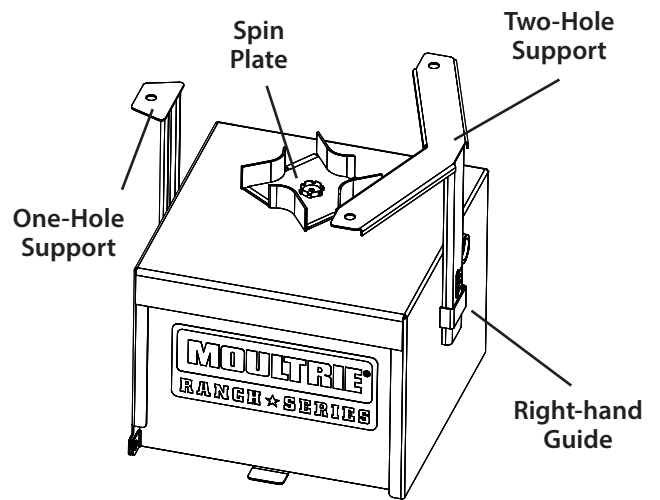

3 While holding the tab on the bottom of the door, pull **up** and then **back** towards you to unhook it from the door guides.

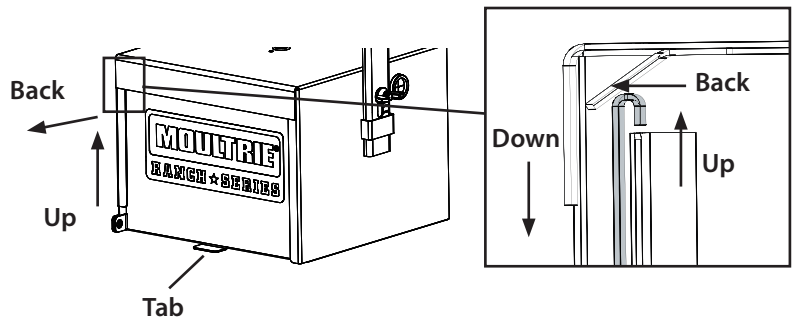

HOT TIP:

Slide the door down to the bottom of the kit, from there you can either hang the door on the keeper tabs or remove it entirely.

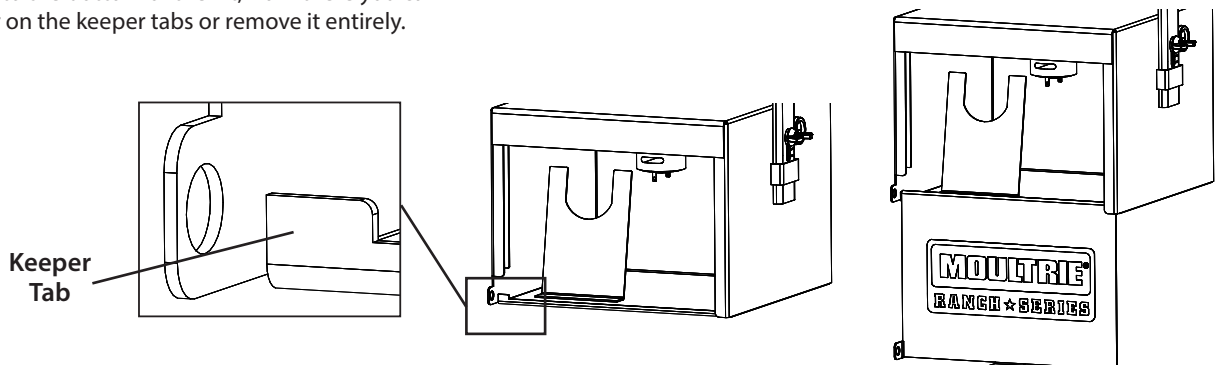

- 4** From the inside of the feeder kit, remove the timer from the stand for clearance and thread (1) **M6 bolt** into each welded nut and tighten, ensuring that the bolts pass through the vertical support adjustment slots.

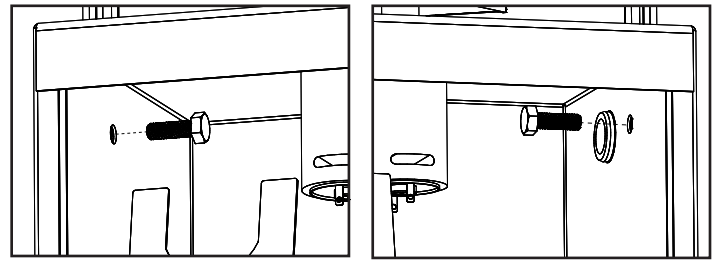
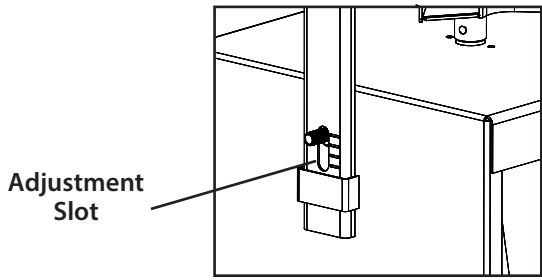

Place (1) **flat washer** and (1) **wingnut** on both protruding bolts on the outside of the feeder kit and hand tighten the wingnut. The feeder kit can be moved up/down to accommodate various feed types.

(The position where the top notch is even with the mounting bolt is recommended for feeding corn)

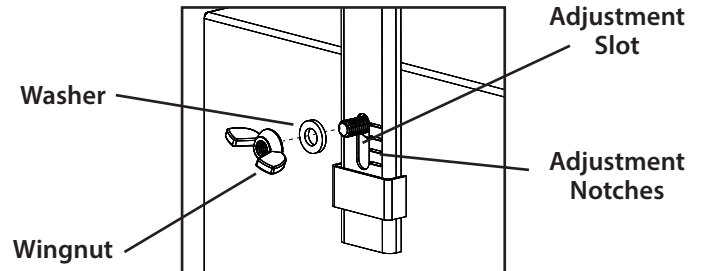

- 5** Place the mounting plate onto the top of the vertical supports with the funnel facing downwards, and all 3 bolt holes aligned.

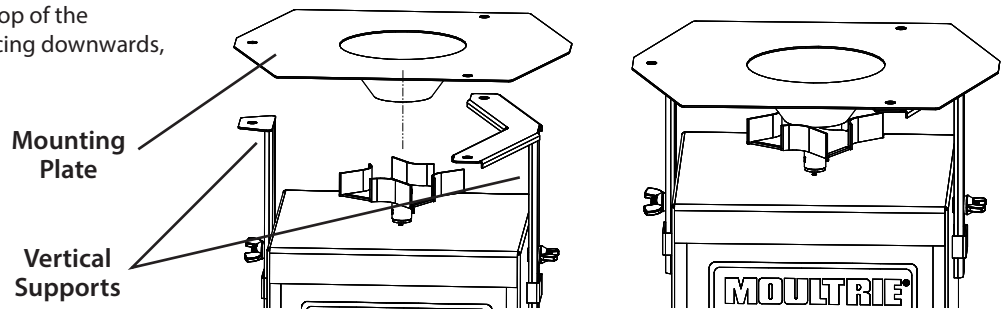

- 6** The kit is now ready to be installed to your hopper. Align the (3) pre-installed nuts in the bottom of the hopper with the (3) holes in the mounting plate and vertical supports, then secure the kit using (3) Flat Washers and (3) Hex Bolts.

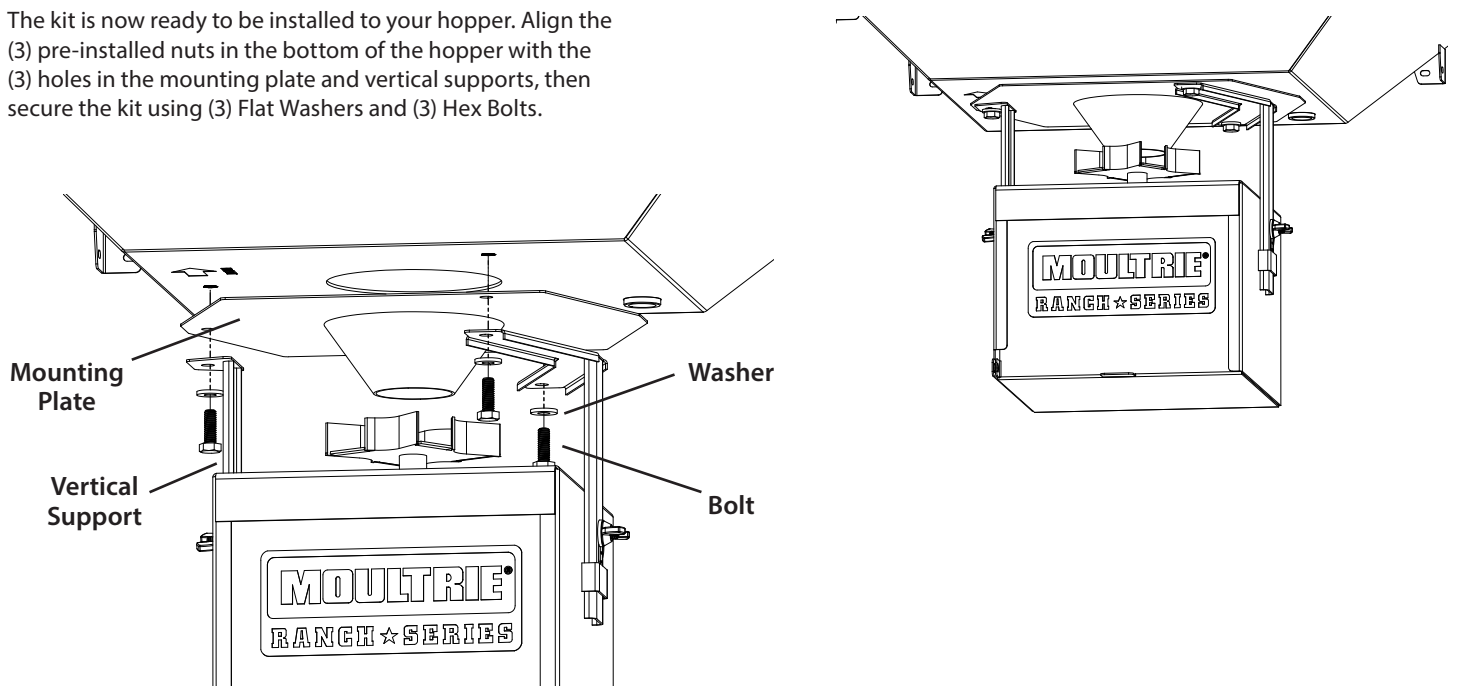

B CONFIGURING AND TESTING FEEDER

1 INSTALL BATTERY: Open Kit by removing carabiner clip and remove door. Install a 12V 7ah battery (Moultrie rechargeable battery MCA-13093) by attaching the Red Wire Connector to the positive (+) terminal and the Black Wire Connector to the negative (-) terminal, making sure that the leads do not touch.

Note: Make sure the rubber protectors are around the wire connectors after installation onto the battery and that the wire connectors are firmly seated on the battery posts and have a snug fit. This helps protect the connectors from touching which can cause damage.

CAUTION: DO NOT REVERSE POLARITY OF THE BATTERY LEADS. DO NOT LET THE BATTERY LEADS COME IN CONTACT WITH ONE ANOTHER WHILE CONNECTED TO A BATTERY. DO NOT LET THE BATTERY TERMINALS CONTACT THE SIDE OF THE FEEDER KIT. THIS CAN CAUSE PERSONAL INJURY OR PROPERTY DAMAGE. IN NO EVENT SHALL PRADCO BE LIABLE FOR ANY DIRECT, INDIRECT, PUNITIVE, INCIDENTAL, SPECIAL CONSEQUENTIAL DAMAGES, TO PROPERTY OR LIFE, WHATSOEVER ARISING OUT OF OR CONNECTED WITH THE USE OR MISUSE OF THIS PRODUCT. YOUR USE OF THIS PRODUCT IS AT YOUR OWN RISK.

2 SET CURRENT TIME: Press the PROGRAM button and SET CURRENT TIME will appear. Press UP or DOWN to set the hour, then press RIGHT to go to the minutes. Press UP or DOWN to set the minutes. Press the BACK button to return to the Main Menu, or press PROGRAM to proceed through the settings.

NOTE: The timer is capable up to 10 feed times, each 1-60 seconds each, and each can operate on any day of the week where each day can be toggled ON/OFF.

3 SET CURRENT DAY: Press the PROGRAM button until the Set Current Day screen appears. Press LEFT or RIGHT to select the current day. Press BACK to return to the Main Menu, or press PROGRAM to proceed through the settings.

4 SET EST. FEED REMAINING: Press the PROGRAM button until the Est. Feed Remaining screen appears. Press UP or DOWN to select the amount of feed you have in the feeder. Press BACK to return to the Main Menu, or press PROGRAM to proceed through the settings.

5 SET FEED TIME: Press the PROGRAM button until the desired Feed Timer appears at the top of the screen. Press the DOWN button until the feed time is flashing. Press PROGRAM to enter edit mode. Press UP or DOWN to set the hour. Press the RIGHT button to go over to the minutes. Press UP or DOWN to set the minutes. Press PROGRAM or BACK to return to the Feed Timer. The factory settings include two feeder times 7am and 6pm, each for 6 seconds.

6 SET DAYS OF THE WEEK: After setting the feed time, press UP so the days of the week start flashing. Press PROGRAM to enter edit mode. By default all days should be enabled. Press LEFT or RIGHT to highlight the desired day. Press DOWN to disable the selected day. Press UP to re-enable the selected day. Once all desired days are selected, press PROGRAM or BACK to return to the Feed Timer.

7 SET RUN DURATION: Press DOWN and LEFT until the RUN DURATION seconds are flashing. Press PROGRAM to enter edit mode. Press UP or DOWN to set desired feed duration. Press PROGRAM or BACK to return to the Feed Timer.

8 SET MOTOR SPEED: Press UP or DOWN until the motor speed setting is flashing at the bottom of the screen. Press PROGRAM to enter edit mode. Press RIGHT or LEFT to select the desired motor setting. Press PROGRAM or BACK to return to the Feed Timer.

When the Feed Timer is blinking at the top of the screen, press PROGRAM or RIGHT to advance to the next feed timer. Repeat for all required feed times.

9 TEST FEEDER: Press the BACK button to reach the Main Menu. Press the TEST button to enter the Test Mode. The Test Duration will appear (this will be the same as the duration as Feed Timer 1). Press UP or DOWN to set the Test Duration. Press PROGRAM. Press RIGHT or LEFT to select desired motor speed. Press PROGRAM to perform test. After a 5 second countdown, the test will commence.

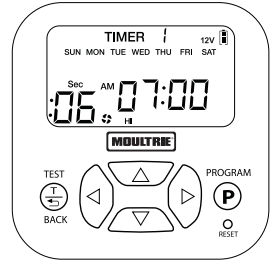
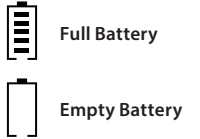

To secure the kit with the door installed, place the carabiner clip through the locking tabs at the lower left corner of the door.

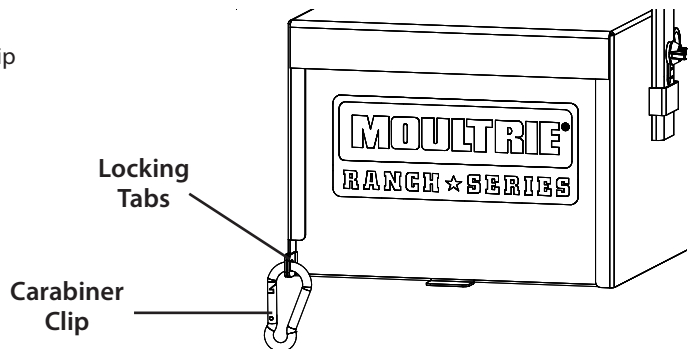

FCC COMPLIANCE

This device complies with part 15 of the FCC Rules. Operation is subject to the following two conditions: (1) This device may not cause harmful interference, and (2) this device must accept any interference received, including interference that may cause undesired operation.

For devices approved under Part 15, the user's manual or instruction manual for an intentional or unintentional radiator shall caution the user about changes or modifications to the device (Section 15.21).

NOTE: This equipment has been tested and found to comply with the limits for a Class B digital device, pursuant to part 15 of the FCC Rules. These limits are designed to provide reasonable protection against harmful interference in a residential installation. This equipment generates, uses and can radiate radio frequency energy and, if not installed and used in accordance with the instructions, may cause harmful interference to radio communications. However, there is no guarantee that interference will not occur in a particular installation. If this equipment does cause harmful interference to radio or television reception, which can be determined by turning the equipment off and on, the user is encouraged to try to correct the interference by one or more of the following measures:

- Reorient or relocate the receiving antenna.
- Increase the separation between the equipment and receiver.
- Connect the equipment into an outlet on a circuit different from that to which the receiver is connected.
- Consult the dealer or an experienced radio/TV technician for help.



Our Service Department will gladly answer any questions you have.
www.moultriefeeders.com/support



Instructions for Ranch Series Varmint Guard

Thank you for your purchase of a Moultrie Ranch Series Varmint Guard. Please read this sheet before operating the unit. If you should have any questions about this product or any other Moultrie product, please contact us using the information on the back of this sheet. Allow us to better serve you by activating your 1-year warranty online at <http://www.moultriefeeders.com/warranty>.

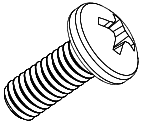

M4 Screw
M4 x 0.7 x 10
Qty. 16



M4 Lock Washer
M4
Qty. 16

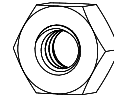

M4 Nut
M4 x 0.7
Qty. 8

A ASSEMBLE THE VARMINT GUARD

1 Remove all hardware from packaging.

2 Unfold all 4 of the Varmint Guard panels.

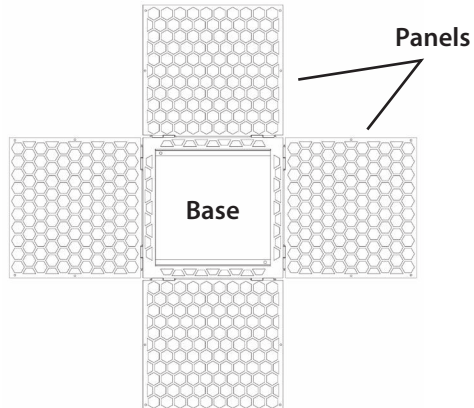

3 Lift two adjacent panels up so that they are at 90 degrees to your work surface.

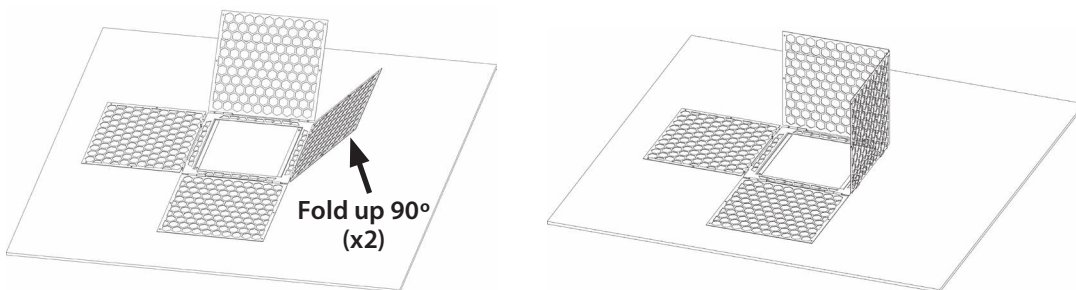

4 Place a support bracket on the outside of the panels, midway up, where the holes will be aligned.

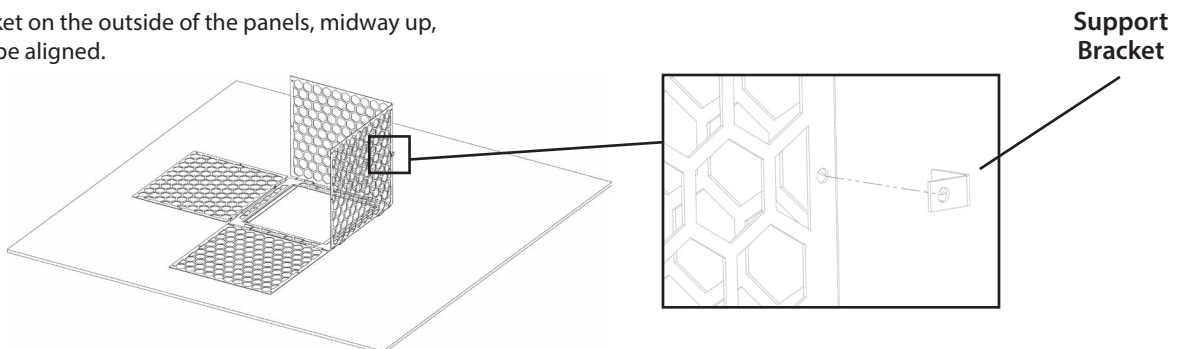

From the outside of the bracket, insert (1) screw with a lock washer through both holes and secure with a nut on the inside. Repeat for the other side of the bracket. Only tighten once both screws are installed.

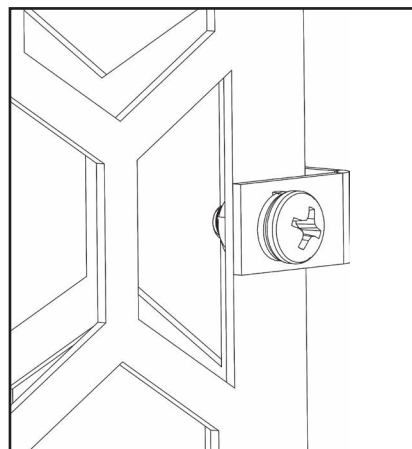
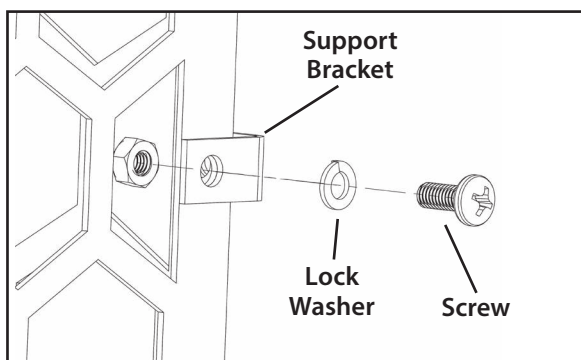

Repeat the previous installation procedure for the 3 remaining corners.

5 Now that you have installed the 4 support brackets, insert the gate into the track located on the bottom side of the base. Be sure that the tab is pointed downwards and inserted into the tracks first.

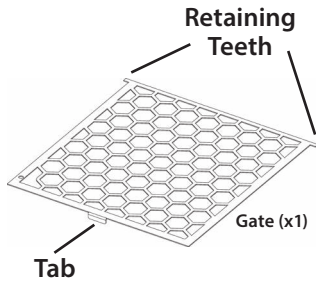
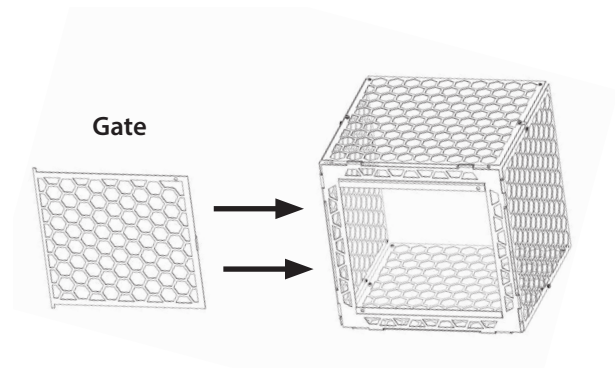

Panels removed in below images for clarity

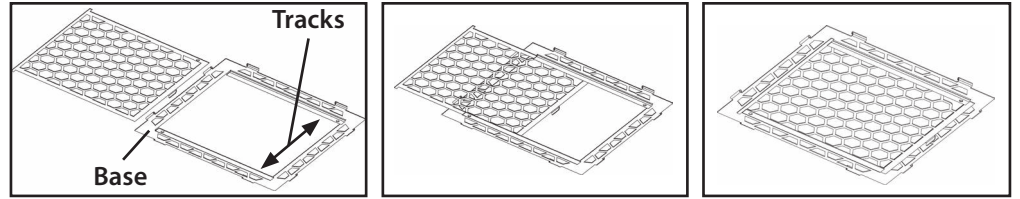

6 Secure the gate in place by clipping the provided carabiner through the locking holes located in both the gate and the base.

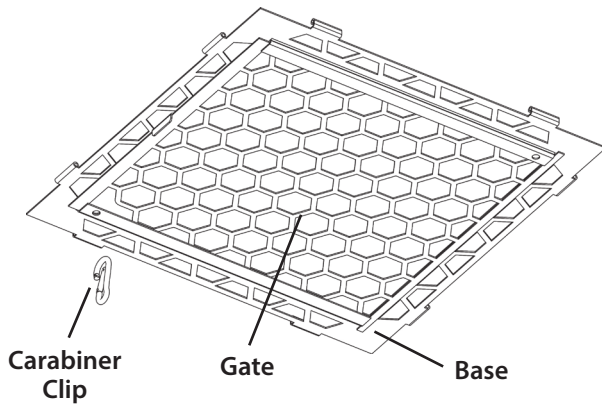

Panels removed in below images for clarity

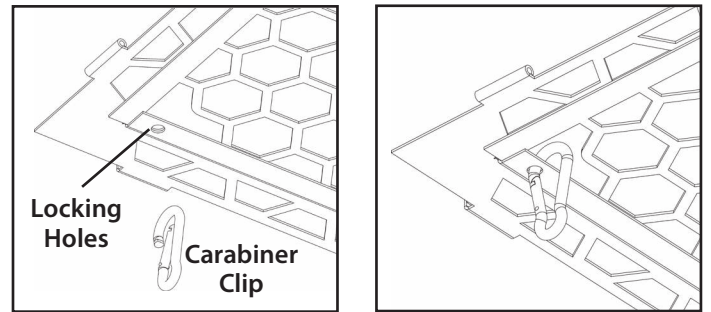

B INSTALLING THE VARMINT GUARD

1 The Varmint Guard is now ready to be installed onto your feeder. Rotate the Varmint Guard so that the gate tab is facing the front of the feeder.

Lift up to the bottom of the feeder with the panels inside of the varmint guard mounts. Align the holes in the mounts with the threaded holes at the top corners of the varmint guard panels. Insert a screw and lock washer hand-tight through each one. Tighten with a Phillips head screwdriver.

The Varmint Guard is fully installed and ready for use.

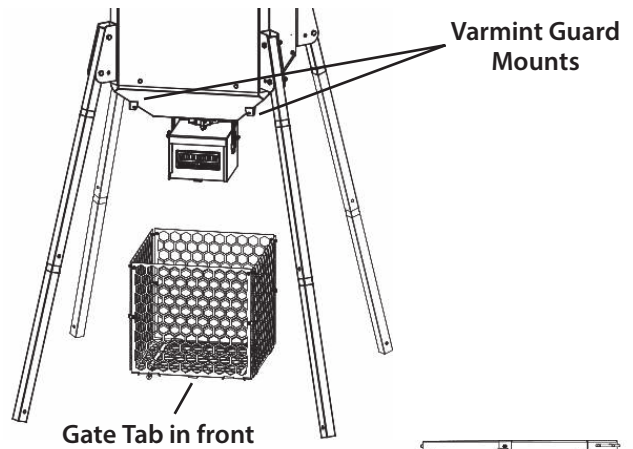

Legs removed in below images for clarity

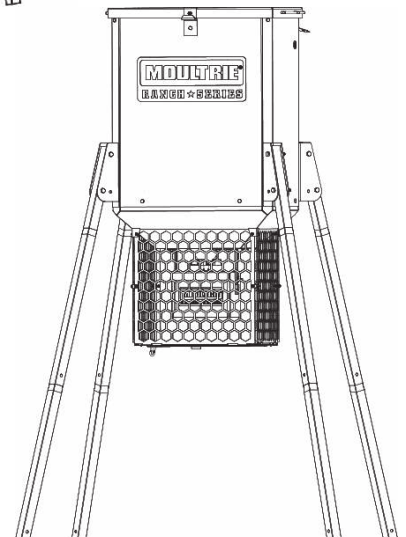
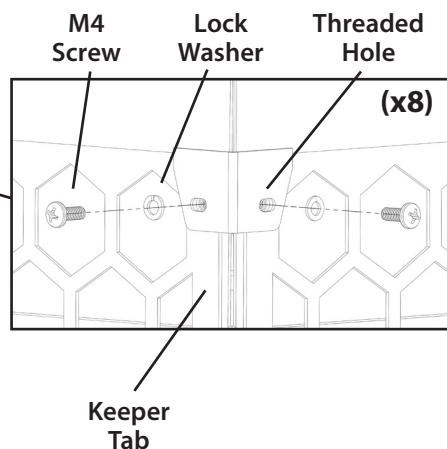
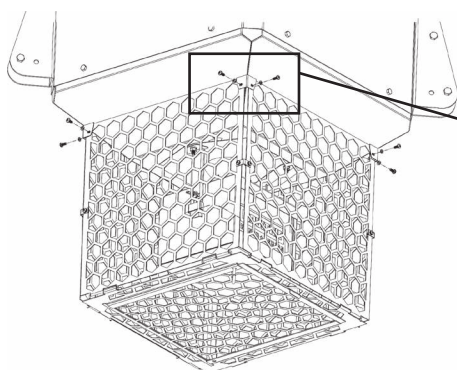

C**GATE OPERATION**

1 To access the feeder kit inside the varmint guard, remove the carabiner clip from the varmint guard. Slide the door backwards about half-way to give your hands room to access the feeder kit.

NOTE: You can also completely remove the door for increased accessibility by pushing it all the way out of the tracks.

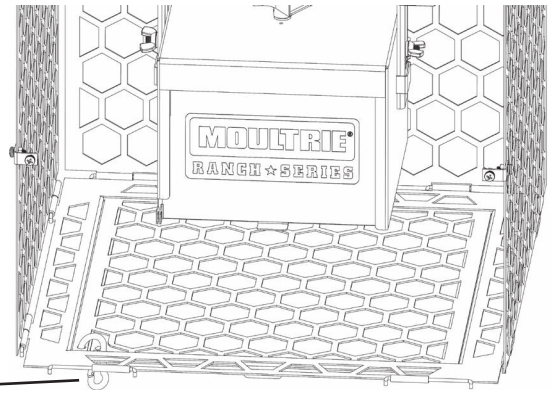

Front Varmint Guard Panel hidden for clarity

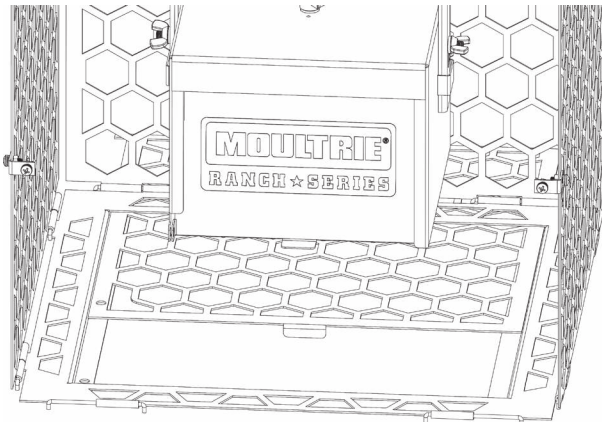

Push gate half-way back

OR

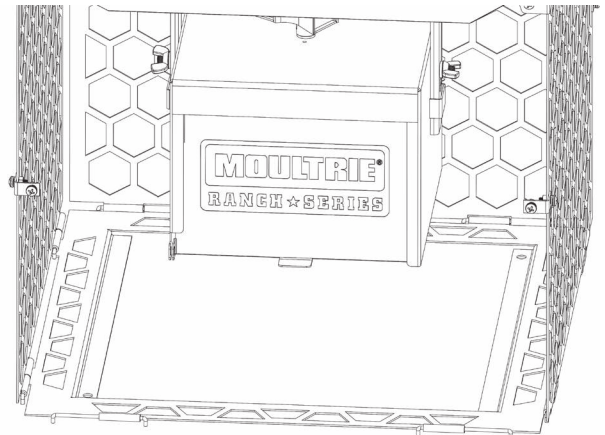

Keep pushing to remove gate completely



Our Service Department will gladly answer any questions you have.
www.moultriefeeders.com/support