

## Wireless Remote Control FastTrack Light Set

### Operating Instructions

#### Features & General Information

The LIGHT IT! Wireless Remote Control LED FastTrack Light Set has been designed to mimic the operation of normal household lighting, but without the time and expense of wiring. Using 433MHz Radio Frequency control (RF) and battery power, we have developed a supplementary lighting system that installs in minutes and offers the utmost in convenience and performance. Unlike infrared systems which require line of sight operation, radio signals penetrate most walls and barriers so that up to 20 lights can be operated with a single touch of the switch. Lights can be located where they are needed most and the switch can be permanently mounted to avoid damage or loss. And, to make the system even more useful and simple to operate, our easy-to-use Group Code feature lets you install and operate up to 8 groups of lights in a household without interference! Another great idea from LIGHT IT!...the leader in wireless lighting solutions.

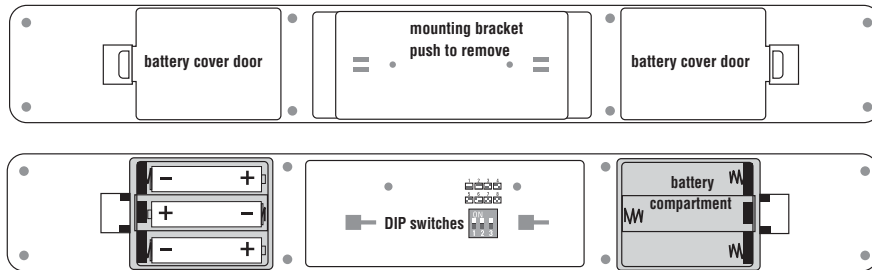

#### Battery Installation & Replacement

##### Light

- 1) Open the two battery cover doors and remove them.
- 2) Install 3 AA batteries in each compartment, making certain to match the polarity as shown on the diagram in the battery compartment.
- 3) Do not mix battery types. Use only fresh batteries. Alkaline are recommended.
- 4) Check light operation to confirm that batteries are correctly installed.
- 5) Replace the battery covers.

##### Remote Control Switch

- 1) Remove the battery cover by depressing the tab on the back of the switch as shown in the diagram.
- 2) Install 2 AAA batteries making certain to match the polarity as shown in the diagram in the battery compartment.
- 3) Do not mix battery types. Use only fresh batteries. Alkaline are recommended.
- 4) Check the switch operation to confirm that batteries are correctly installed.
- 5) Replace the battery cover.

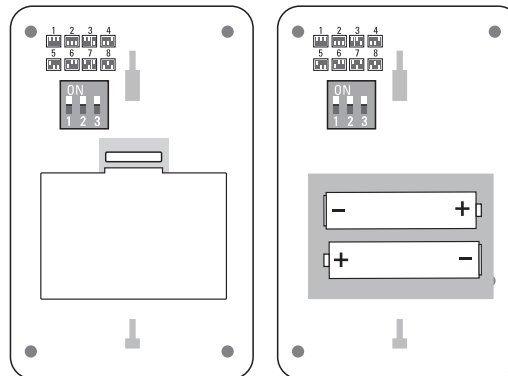

#### Group Code/ DIP Switches

Each light and switch comes with 3 DIP switches that enable the user to operate 2 or more groups of lights without interfering with each other. These switches come preset from the factory and will not require adjustment unless:

- 1) You are adding lights to the group, or
- 2) You are operating 2 or more groups of lights within 60' of each other.

#### Setting the Group Code/Adding Lights to Your Group

We recommend that you start with the remote control switch and then adjust the lights to match the setting on the switch. You may add any combination of up to 20 lights and switches as desired.

#### Remote Control Switch

- 1) Remove the mounting bracket.
- 2) Move the DIP switches gently back and forth to one of 8 possible combinations on the switch.
- 3) Replace the mounting bracket.

#### Lights

- 1) Remove the battery cover.
- 2) Use a pointed object to gently move the DIP switches to match the settings on the switch.
- 3) Check operation by pressing the remote control switch on and off.
- 4) Replace the battery cover.
- 5) Repeat the process with all of the remaining lights in the group.

#### Adding Lights & Switches

- 1) Simply follow the instructions above and arrange the 3 DIP switches to match the code of the group to which you are adding lights.
- 2) We do not recommend groups in excess of 20 lights and switches (total combined).

#### Battery Saver

To prevent unintended battery use, the Remote Control Switch comes with 3 user-selectable settings: 30, 60 or 120 minutes. The Switch will automatically shut off the lights should you forget. This feature cannot be turned off. Only the time period can be selected.

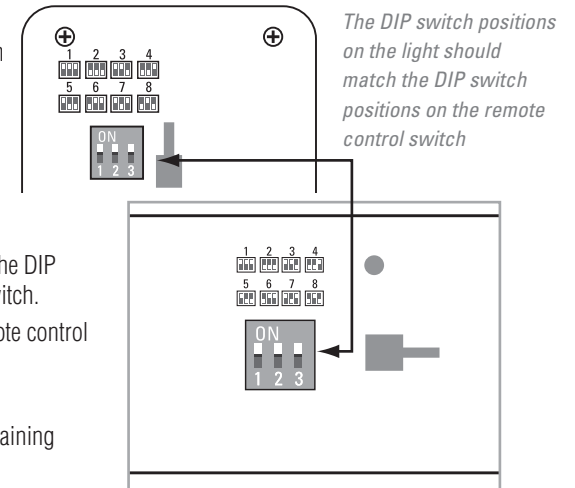

Battery saver is located on the right side of the switch.

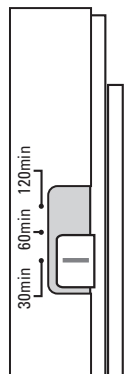

## Installing the Lights and Switch

The chief benefit of using 433Mhz radio frequency control is that it works through most common barriers (walls, clothing, shelving, etc.) and so does not require line of sight operation as is the case with infrared systems. Therefore you can choose a switch location that is most convenient for you to operate the system. You can locate the lights where they are needed most without concern for the barriers that might exist. This provides the user with enormous flexibility. Lights can even be located in different rooms, different closets, or even on different floors of the house if desired.

### Remote Control Switch Installation

We recommend choosing a permanent location that offers the most convenient access. Although the switch may be removed from the mounting plate and hand carried, there is typically no need to do so and we recommend against to prevent loss or damage. Remove the mounting plate from the back of the unit and follow the directions below to secure the mounting plate to the desired location.

### Light Installation

To begin, we recommend choosing the desired location for both the switch and the lights and testing the operation of the system before commencing the actual installation. Locate the lights where they are most needed without regard for physical barriers and test by turning them on and off several times. You may occasionally experience a slight delay in one or more lights. This is normal. Although we have made every effort to synchronize the operation of these lights, external conditions may cause a slight delay and on rare occasions the lights may not turn on or off. If this happens, simply turn the lights off and then on again. If it happens repeatedly, there may be external factors that are disrupting the signal and the location of the light may need to be altered. Once the final location of the lights has been determined, please remove the battery cover and follow steps below to mount the light.

Please Note: For optimal performance we recommend installing the lights 12" or more apart from each other.

## Mounting Instructions

Determine the location of the lights and switch, as noted above, then remove the mounting plate from the switch and the battery cover/mounting plate from the light and follow the steps below to mount them.

**Double-sided Tape Mounting:** Be certain the surface of the mounting location is clean and dry. Peel off the protective film and attach the tape to the mounting plate. Peel off the remaining film and press the mounting plate firmly on to the mounting surface. Be aware that the tape may damage painted surfaces when it is removed.

**Screw Mounting – Wood Surfaces:** Mount the bracket using two screws. Drill a 1/16" pilot hole, insert the screw and gently tighten it until the mounting plate is secure. Do not over tighten.

**Screw Mounting – Drywall:** Mount the bracket using two screws and anchors. Drill 1/4" pilot holes, insert drywall anchors and press firmly until they are fully seated into the wall. Insert the screws and gently tighten until the mounting plate is secure. Do not over tighten the screws.

## Operating the Lights

You can operate the lights one of two ways: manually or by using the wireless remote control switch.

### Manual Operation

- 1) Press the power button once to turn the light on.
- 2) Press again to turn it off.
- 3) To dim the light, press and hold the power button until the desired light level is reached and release.

## Remote Control Switch Operation

- 1) Press the on symbol **I** once to turn the lights on.
- 2) Press the off symbol **O** once to turn the lights off.
- 3) To dim the lights, press and hold the on symbol **I** until the desired light level is reached, then release.

### FCC Statement

This device complies with Part 15 of the FCC Rules. Operation is subject to the following two conditions:  
**(1)** This device may not cause harmful interference, and  
**(2)** this device must accept any interference received, including interference that may cause undesired operation.

**NOTE:** This equipment has been tested and found to comply with the limits for a Class B digital device, pursuant to Part 15 of the FCC Rules. These limits are designed to provide reasonable protection against harmful interference in a residential installation. This equipment generates, uses and can radiate radio frequency energy and, if not installed and used in accordance with the instructions, may cause harmful interference to radio communications.

However, there is no guarantee that interference will not occur in a particular installation. If this equipment does cause harmful interference to radio or television reception, which can be determined by turning the equipment off and on, the user is encouraged to try to correct the interference by one or more of the following measures:

- Reorient or relocate the radio or TV antenna.
- Increase the separation between the lights and the radio or TV.
- Consult the dealer or an experienced radio/TV technician for help.

## Limited 2 Year Warranty

This product is guaranteed against defect and workmanship for a period of 2 years from the date of purchase. If the product fails during normal use, please return it to the place of purchase together with a copy of the sales receipt. Alternatively, you may contact us at [info@fulcrumproducts.com](mailto:info@fulcrumproducts.com) and we will arrange to have the product replaced or repaired at our discretion.

**WARNING:** Modifications to this or other products by anyone other than an authorized repair agent may void that product's warranty.

### Specifications – Model # 30036-308

Operating Mode: 433MHz radio frequency control

Operating Distance: 60'

LED Type: 4 x SMD

Lumens: 85 lumens

Color Temp: 4000 Kelvin (warm white)

Light Battery Type: AA (x6), alkaline recommended

Light Battery Life: approx. 55-60 hours

Light Battery Standby Life: approx. 12 months\*

Switch Battery Type: AAA (x2), alkaline recommended

Switch Battery Standby Life: approx. 30 months\*

*\*actual battery life will vary according to frequency of use.*

### Included Items

Screws & drywall anchors • Operating Instructions

### CAUTION

Do not mix battery types

Use only fresh batteries for reliable operation

Do not look directly into the light

