

P.O. Box 1270 * 1504 S. Kaufman . . . ENNIS, TEXAS 75120

1-800-627-2441
972-875-6555 Ennis
972-878-6555 Dallas
800-605-9558 Fax

KORAL INDUSTRIES, INC. PRODUCT/SPECIFICATION SHEET

Revised 03/05

MODEL TS121LH/126RH TUB/SHOWER COMBINATION

PRODUCT OVERVIEW

The Koral model TS121LH/126RH TUB/SHOWER COMBINATION is a full sized unit designed with an acrylic built-in grab bar and above floor rough-in, maintaining the high quality construction standards found in all Koral units. The easy care and cleaning of this unit along with a variety of colors makes this the ideal solution to an economical bath design with beauty and style.

PRODUCT FEATURES

- Easy care gelcoat/fiberglass construction
- Textured slip-resistant bottom
- Five year warranty on manufacturing defects
- Approved and accepted by IAPMO, UPC, FHA/HUD
- Acrylic grab bar with a weight capacity of approximately 250 lbs.

PRODUCT OPTIONS

- Available in a variety of colors to compliment any decor



KORAL MODEL TS121LH/126RH TUB/SHOWER COMBINATION

CALL FOR ADDITIONAL PRODUCT INFORMATION

*Pictures may not always reflect standard features.

KORAL INDUSTRIES INC.



Industries, INC.

1-800-627-2441
972-875-6555 Ennis
972-878-6555 Dallas
800-605-9558 Fax

P.O. Box 1270 * 1504 S. Kaufman . . . ENNIS, TEXAS 75120

KORAL INDUSTRIES, INC. PRODUCT/SPECIFICATION SHEET

Revised 03/05

**MODEL TS121LH/126RH
TUB/SHOWER COMBINATION**

DIMENSIONAL DATA

Outside Dimensions:
59 3/4" w x 32 1/4" d x 72 3/4" h
Inside Dimensions:
53 1/4" w x 22 1/4" d

Dimensions may vary 1/4"

SPECIFICATIONS

Koral Industries employs independent testing to certify that Koral Industries meets the requirements of ANSI Z124.1 or ANSI Z124.2 and WWP-541/3A or WWR-541/7B.

APPROVALS/ACCEPTANCE

IAPMO, UPC, FHA/HUD

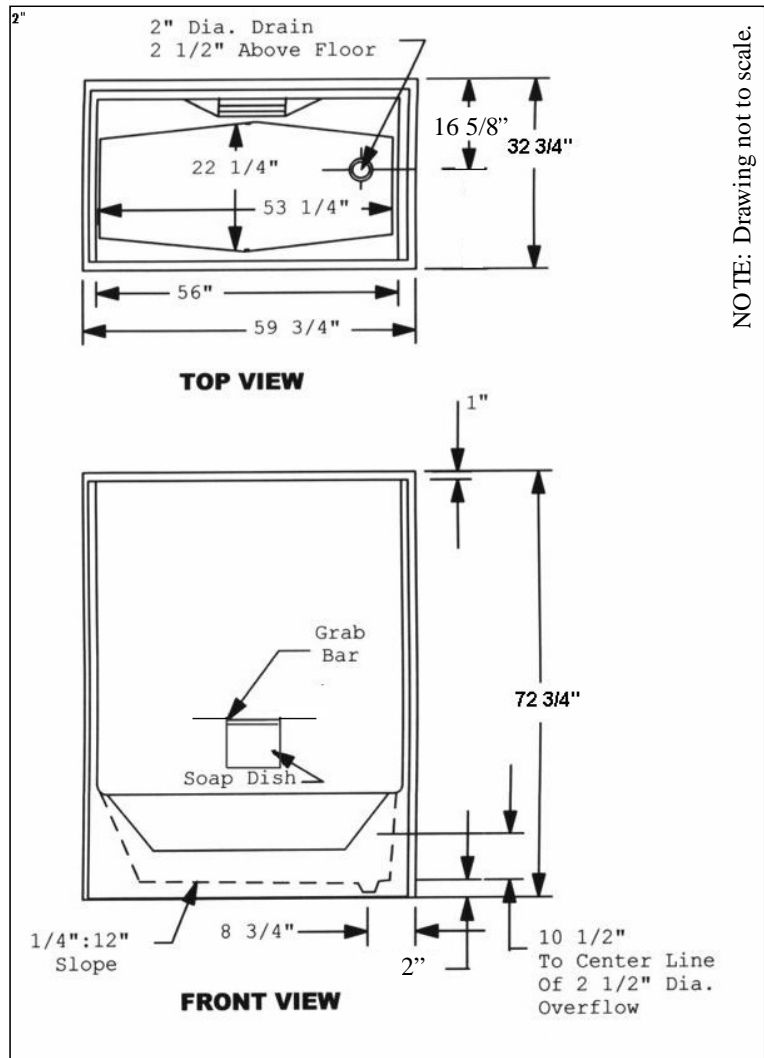

CALL FOR ADDITIONAL PRODUCT INFORMATION
Clerical errors subject to correction

KORAL INDUSTRIES INC.