



---

# JOBBOX

---

***PREMIUM STORAGE SOLUTIONS***

**THE LEADER IN SECURITY, STRENGTH AND DURABILITY  
FOR ON-SITE, SAFETY, AND TRUCK STORAGE**



# At JOBBOX we understand the importance of protecting your equipment.

Whether it's protection from theft, shelter from the elements, or improved on-site safety, JOBBOX on-site and truck storage solutions offer superior strength, security, and durability. We utilize innovative design, in-depth research, cutting-edge technology, and extensive testing to continually improve the performance and value of our products.

- **JOBBOX On-Site Storage Solutions** provide premium protection for valuable tools and equipment with features like our Site-Vault™ Security System, EZ-Loader® Skid Bolsters, Staked and Welded Hinges, and Heavily Reinforced Lids.
- **JOBBOX Truck Storage Boxes** offer ultimate security with our Self-Adjusting Dual Rotary GearLock II™ Latching Mechanism, RSL® Deep Beveled Edge Lids, and Industrial-Grade Steel Hinges.
- **JOBBOX Flammable Storage Cabinets and Cans** add improved safety and superior heat and fire resistance to legendary JOBBOX quality, security, and durability with innovative features like EZ-Level™ Bolsters, Bright White Cabinet Interiors, Anti-Tip Bolster Design, and Fork Lift Capability.

SEE THE VIDEO  
5 REASONS TO BUY JOBBOX® ON-SITE STORAGE

## TABLE OF CONTENTS

### On-Site Storage Solutions

- Chests ..... 4
- Slope Lid Chest ..... 5
- High Capacity Drop-Front Chests ..... 6
- Piano Boxes..... 8
- High Capacity Piano Boxes ..... 9
- Drop-Front Boxes..... 10
- Field Office..... 11
- Cabinets..... 12
- Drawer Cabinet..... 13
- Bin Cabinet ..... 14
- Clam-Shell Cabinet ..... 15
- Rolling Workbenches ..... 16
- Welder's Box & Small Chests ..... 17
- On-Site Storage Accessories..... 18

### Safety Storage Solutions

- Standard Safety Storage Cabinets ..... 22
- Self-Closing Safety Storage Cabinets ..... 24
- Storage Cans ..... 26

### Truck Storage Solutions

- Crossovers ..... 30
- Crossover Fitment Charts ..... 34
- Innersides ..... 36
- Truck Chests..... 38
- Underbeds ..... 40
- Topsides..... 42
- Drawer Storage..... 44
- Liquid Transfer Tanks ..... 46

### KargoMaster® Ladder Racks

- Ladder Racks ..... 49
- Rack Accessories..... 51
- How to Measure Your Truck..... 52
- Warranty Information..... 53

# ON-SITE STORAGE



《 FIELD OFFICE 》



《 DROP FRONT CHEST 》



《 STORAGE CHEST 》



《 STORAGE CABINET 》



《 PIANO BOX 》

# ON-SITE STORAGE

◀ PREMIUM FEATURES ▶

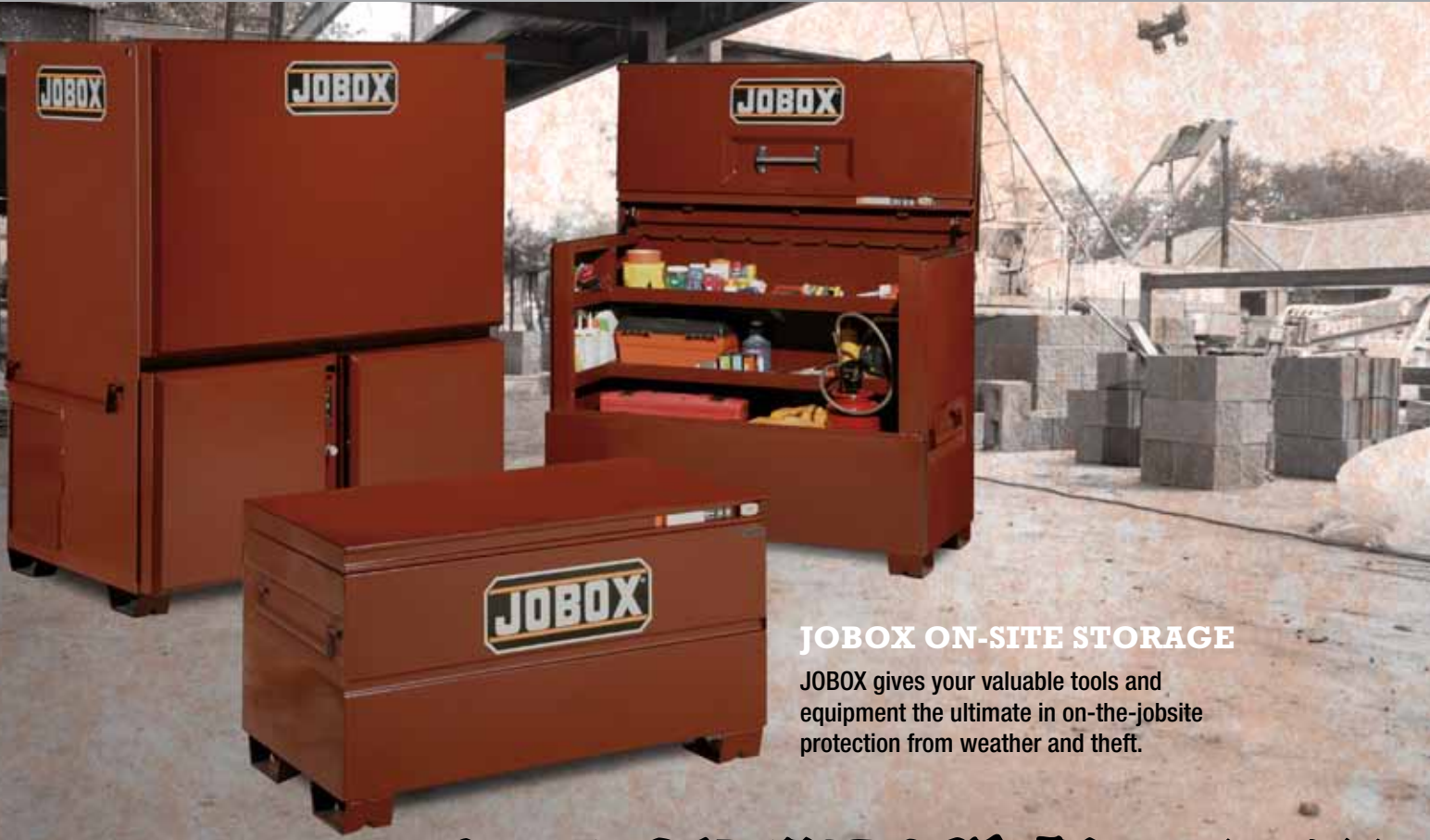

## JOBBOX ON-SITE STORAGE

JOBBOX gives your valuable tools and equipment the ultimate in on-the-jobsite protection from weather and theft.

## SITE-VAULT™ SECURITY SYSTEM



- Patented System has Full-Length Steel Lock Console with Three Locking Points
- Formed Lid Sides Welded to Lid Bolsters Resist Pry Bar Entry
- Padlock installs inside fully-welded 14-Gauge Steel Housing
- Fluorescent Reflective Orange Tape indicates when Chest is unlocked

SEE THE  
▶ VIDEO



# ON-SITE STORAGE

◀ PREMIUM FEATURES ▶

## EZ-LOADER®



### SKID BOLSTERS

- Patent-Pending Skid Bolsters provide time-saving and safety features
- Easily load or unload from any side on trucks, trailers, or docks
- One-piece 7-Gauge Steel Skid Bolsters reinforce the bottom of box for heavier loads and protect from drops

SEE THE  
▶ VIDEO



### STAKED & WELDED HINGES



- 14-Gauge Steel
- 3/8" Continuous Hinge with 1/4" Steel pin and extra-large 1" knuckles
- Pin cannot be driven out



### GRIP-RITE™ LIFTING CHANNEL



- Increases Door or Lid Strength and provides easier grasping and opening



### HEAVILY REINFORCED LID



- Patented Full-Length "A-Frame" Lid Bolster
- Resists bending from cargo placed on top of the box and from attempted break-ins



### RECESSED HANDLES



- Extra tall and deep recess areas prevent pinched fingers and damage to the handle



### OPTIONAL CASTERS



- Casters provide added mobility
- Set includes one pair each of fixed and swiveling casters

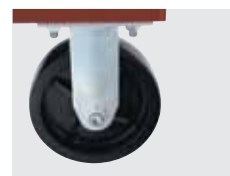

### TEXTURED POWDER PAINT FINISH



- High-Quality Powder Paint improves durability over liquid paint

**10x**

corrosion resistance

**5x**

abrasion resistance

**2x**

chip resistance

**2x**

scratch resistance

Customizeable Color Options  
[Minimum Order Quantity Required]



## HEAVY-DUTY CHESTS



The toughest chests in the world. Designed for premium access, weather resistance, and security, the JOBOX chest yields a plethora of features including four-way skid bolsters, and a visual, three-point locking system. Need help with organization? Check out JOBOX's chest accessories including divider kits and removable trays.



Grip-Rite™ Lifting Channel for Easier Opening



Full-Length "A-Frame" Lid Bolster

1" Locking Arms



Recessed Handles

Welded Corner Gussets Reinforce Body



- Site-Vault™ Security System with Bolt-Cutter Proof Housing
- Full-Length Steel Lock Console with Three Locking Points
- Fully-Welded Padlock Housing



Staked & Welded Hinge



View Casters on p.18



- EZ-Loader® Skid Bolsters
- Formed-In Reinforcements Strengthen Skid Bolsters
- 7-Gauge, One-Piece Steel Bolsters with Holes to install Optional Casters

Cat. No.	Description	Length	Width	Height	Usable Cu. Ft.	Shipping Cu. Ft.	App. Ship Wt.
1-652990	36" Long	36 in	20 in	23.75 in	8.3 ft³	10 ft³	98.00 lb
1-653990	42" Long	42 in	20 in	23.75 in	9.3 ft³	13.8 ft³	118.00 lb
1-654990	48" Long	48 in	24 in	27.75 in	15.4 ft³	22.3 ft³	148.00 lb
1-655990	60" Long	60 in	24 in	27.75 in	19.3 ft³	27.3 ft³	182.00 lb
1-656990	48" Long	48 in	30 in	33.38 in	24.3 ft³	33.3 ft³	190.00 lb
1-658990	72" Long	72 in	24 in	27.75 in	23.2 ft³	30.9 ft³	220.00 lb

# SLOPE LID CHEST



Hold your morning meetings around the JOBOX slope lid chest. The locking lid makes the perfect surface for working on plans and laptops on the job site. Also includes the popular Lift-N-Stow shelf for more storage choices.

-  Site-Vault™ Security System with Bolt-Cutter Proof Housing
-  Fully-Welded Padlock Housing
-  Full-Length Steel Lock Console with Three Locking Points

Lid Support Rod Props up Lid for a Flat Working Surface

Full-Length "A-Frame" Lid Bolster

1" Locking Arms

Staked & Welded Hinge

Full-Length Reinforcing Channel

EZ-Loader® Skid Bolsters

Formed-In Reinforcements Strengthen Skid Bolsters

7-Gauge, One-Piece Steel Bolsters with Holes to install Optional Casters

Site-Vault™ Security System with Bolt-Cutter Proof Housing

Fully-Welded Padlock Housing

Full-Length Steel Lock Console with Three Locking Points

Grip-Rite™ Lifting Channel for Easier Opening

Lift-N-Stow Hinged Shelf to Store Bulky Items in the Bottom

Recessed Handles

SEE THE VIDEO



Cat. No.	Length	Width	Height	Usable Cu. Ft.	Shipping Cu. Ft.	App. Ship Wt.
1-680990	60 in	30 in	39.5 in	32.7 ft³	45.5 ft³	243.00 lb

# HIGH-CAPACITY DROP-FRONT CHEST



- Site-Vault™ Security System with Bolt-Cutter Proof Housing
- Full-Length Steel Lock Console with Two Locking Points
- Fully-Welded Padlock Housing

An Industry First, the JOBBOX High Capacity Drop-Front Chest combines access with legendary JOBBOX toughness and security. The reinforced front drops down to an amazingly low 8 degree loading angle allowing users to easily roll larger, heavier objects such as generators, spools, and large tools into the chest.



Grip-Rite™ Lifting Channel for Easier Opening

Lid Lowering Assist Shock

Extra Deep and Wide Storage Bins

Four-Corner U-Bolt Tie-Down Points

44" Wide Low Incline Loading Ramp with 8° Loading Angle

Pad-Lockable Ramp

Full-Length "A-Frame" Lid Bolster

Staked & Welded Hinge

1" Locking Arm

Power Cord Access Hole

Recessed Handles

SEE THE VIDEO



- EZ-Loader® Skid Bolsters
- Formed-In Reinforcements Strengthen Skid Bolsters
- 7-Gauge, One-Piece Steel Bolsters with Holes to install Optional Casters

Cat. No.	Length	Width	Height	Usable Cu. Ft.	Shipping Cu. Ft.	App. Ship Wt.
1-657990	60 in	31 in	45 in	41.5 ft³	50.8 ft³	340.00 lb



# CHEST ACCESSORIES

FOR MODEL #1-657990

## ACCESSORY SUPPORT BAR



- 1-1/2" Square Steel Tube is the core component needed to support accessories

Cat. No.	App. Ship Wt.
630990	5.0 lb

## PEG BOARD



- Can be mixed and matched side-by-side with the Parts Bin Board

Cat. No.	App. Ship Wt.
632990D	10.0 lb

## TOOL & EQUIPMENT HOOKS



- Industrial Grade Hooks for hanging harnesses, rope, or chains
- Easy-to-Position and Quick to Remove
- Come in a pack of six

Cat. No.	App. Ship Wt.
601990	7.0 lb

## BACK WALL SHELF



- Tightly secures shelf to chest, removable when needed
- Includes Hardware

Cat. No.	App. Ship Wt.
631990	15.0 lb

## PARTS BIN BOARD



- Can be mixed and matched side-by-side with Peg Board
- Supports most small parts bins

Cat. No.	App. Ship Wt.
633990	12.0 lb

## PIANO BOXES



The perfect combination of storage space, organization, and security, the world renowned JOBOX Piano Box is a job site must have. Two storage bins on both side walls and the JOBOX Lift-n-Stow gives you room to store any item and the Sit-Vault lock system will ensure that your valuables remain safe and secure.

- Site-Vault™ Security System with Bolt-Cutter Proof Housing
- Full-Length Steel Lock Console with Three Locking Points
- Fully-Welded Padlock Housing

Formed Lid Sides Welded to Lid Bolsters Resist Pry Bar Entry



Staked & Welded Hinge

Gas Spring Door Lifts with Quick-Release Mounts



Guards Protect Gas Springs from Damage and Jamming



Recessed Handles



- EZ-Loader® Skid Bolsters
- Formed-In Reinforcements Strengthen Skid Bolsters
- 7-Gauge, One-Piece Steel Bolsters with Holes to install Optional Casters



Formed Side Wall Design Allows the Door to Overlap Walls when Closed

Door opens to a full 90°

Punched Holes for Hanging Safety Harnesses

Two Storage Bins on Both Side Walls



Lift-N-Stow Shelf

Front Panel's Low Height Provides Easier Loading of Equipment

Cat. No.	Length	Width	Height	Usable Cu. Ft.	Shipping Cu. Ft.	App. Ship Wt.
1-681990	48 in	31 in	50 in	38 ft³	49 ft³	286.00 lb
1-682990	60 in	31 in	50 in	47.5 ft³	60 ft³	326.00 lb
1-688990	60 in	31 in	38 in	34.5 ft³	45 ft³	283.00 lb
1-689990	74 in	31 in	50 in	56.5 ft³	73 ft³	423.00 lb

# HIGH-CAPACITY PIANO BOX



Standing at nearly 5' this behemoth provides three center and side storage shelves, punched holes for hanging safety harnesses and tethered tools. The High-Capacity Piano Box offers 75% more storage capacity than our popular Piano Box.



- Site-Vault™ Security System with Bolt-Cutter Proof Housing
- Full-Length Steel Lock Console with Three Locking Points
- Fully-Welded Padlock Housing



Guards Protect Gas Springs from Damage and Jamming

Gas Spring Door Lifts with Quick-Release Mounts



Staked & Welded Hinge



Lift-N-Stow Shelf



Recessed Handles



- EZ-Loader® Skid Bolsters
- Formed-In Reinforcements Strengthen Skid Bolsters
- 7-Gauge, One-Piece Steel Bolsters with Holes to install Optional Casters



Formed Side Wall Design Allows the Door to Overlap Walls when Closed

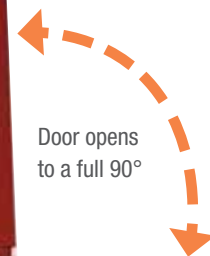

Door opens to a full 90°

Punched Holes for Hanging Safety Harnesses

Three Storage Bins on Both Side Walls

Three 500 lb. Capacity Deep Full-Width Shelves

Front Panel's Low Height Provides Easier Loading of Equipment

SEE THE VIDEO



Cat. No.	Length	Width	Height	Usable Cu. Ft.	Shipping Cu. Ft.	App. Ship Wt.
1-685990	74 in	34.63 in	63 in	85.7 ft³	92.2 ft³	500.00 lb

# DROP-FRONT PIANO BOXES



Got heavy equipment? No Problem. The Drop Front Piano Box offers an industry first, bolster reinforced ramp making it easy to roll or put heavy items in the bottom. Access doesn't have to mean compromise in security, JOBBOX's drop down ramp is secured with two heavy-duty pad lockable sliding gate bolts.



Guards Protect Gas Springs from Damage and Jamming



Staked & Welded Hinge

Gas Spring Door Lifts with Quick-Release Mounts



Formed Side Wall Design Allows the Door to Overlap Walls when Closed



Recessed Handles

Front Panel's Low Height Provides Easier Loading of Equipment



- EZ-Loader® Skid Bolsters
- Formed-In Reinforcements Strengthen Skid Bolsters
- 7-Gauge, One-Piece Steel Bolsters with Holes to install Optional Casters



- Site-Vault™ Security System with Bolt-Cutter Proof Housing
- Full-Length Steel Lock Console with Three Locking Points
- Fully-Welded Padlock Housing

Door opens to a full 90°

Punched Holes for Hanging Safety Harnesses

Two Storage Bins on Both Side Walls

Lift-N-Stow Shelf



Reinforced Ramp Locks with two Internal Sliding Gate Bolts and Padlock

Tapered Drop-Down Ramp for Easily Rolling Heavy Items In and Out

SEE THE VIDEO



Cat. No.	Length	Width	Height	Shipping Cu. Ft.	App. Ship Wt.
1-683990	60 in	30 in	50 in	60 ft³	405.00 lb
1-684990	74 in	30 in	50 in	73 ft³	468.00 lb

# FIELD OFFICE



Your office away from the office, only much more organized, with loads of storage and world class durability. The office center provides an extra-large, lockable desktop with high visibility white interior and hanging pegs. Plenty of storage space including an easy access rear storage locker for longer tools and equipment.



Door Safety Pin Latch Prevents Accidental Door Closing

Rain Gutters

Large Lifting Handles

30 cu. ft. Side Storage Locker



- EZ-Loader® Skid Bolsters
- Formed-In Reinforcements Strengthen Skid Bolsters
- 7-Gauge, One-Piece Steel Bolsters with Holes to install Optional Casters



Full-Length Heavy-Duty Door Hinges

Overhead Tube Storage

Lid Lowering Assist Shock

Steel Pegboard for Hanging Storage of Smaller Items

Lockable, Large Desktop Can Be Propped Into a Flat Working Surface

Stainless Steel Door Hinges Resist Rust

Built-In Door Storage Shelves

Patented One-Handle Lock Operation Opens Top and Bottom Doors

SEE THE VIDEO



Cat. No.	Length	Width	Height	Storage Cap. Upper	Storage Cap. Lower	Usable Cu. Ft.	Shipping Cu. Ft.	App. Ship Wt.
1-674990	63 in	42 in	80 in	60.6 ft <sup>3</sup>	9.4 ft <sup>3</sup>	100 ft <sup>3</sup>	123.5 ft <sup>3</sup>	660.00 lb

# HEAVY-DUTY CABINETS



Organization how you want it. With four models to choose from with varying storage capacity and door options, JOBBOX cabinets give you the power to make organizing your job site, plant floor, or maintenance bay a cinch. With the innovative foot operated latch and Anti-Tip bolsters you also get first class accessibility and safety features.

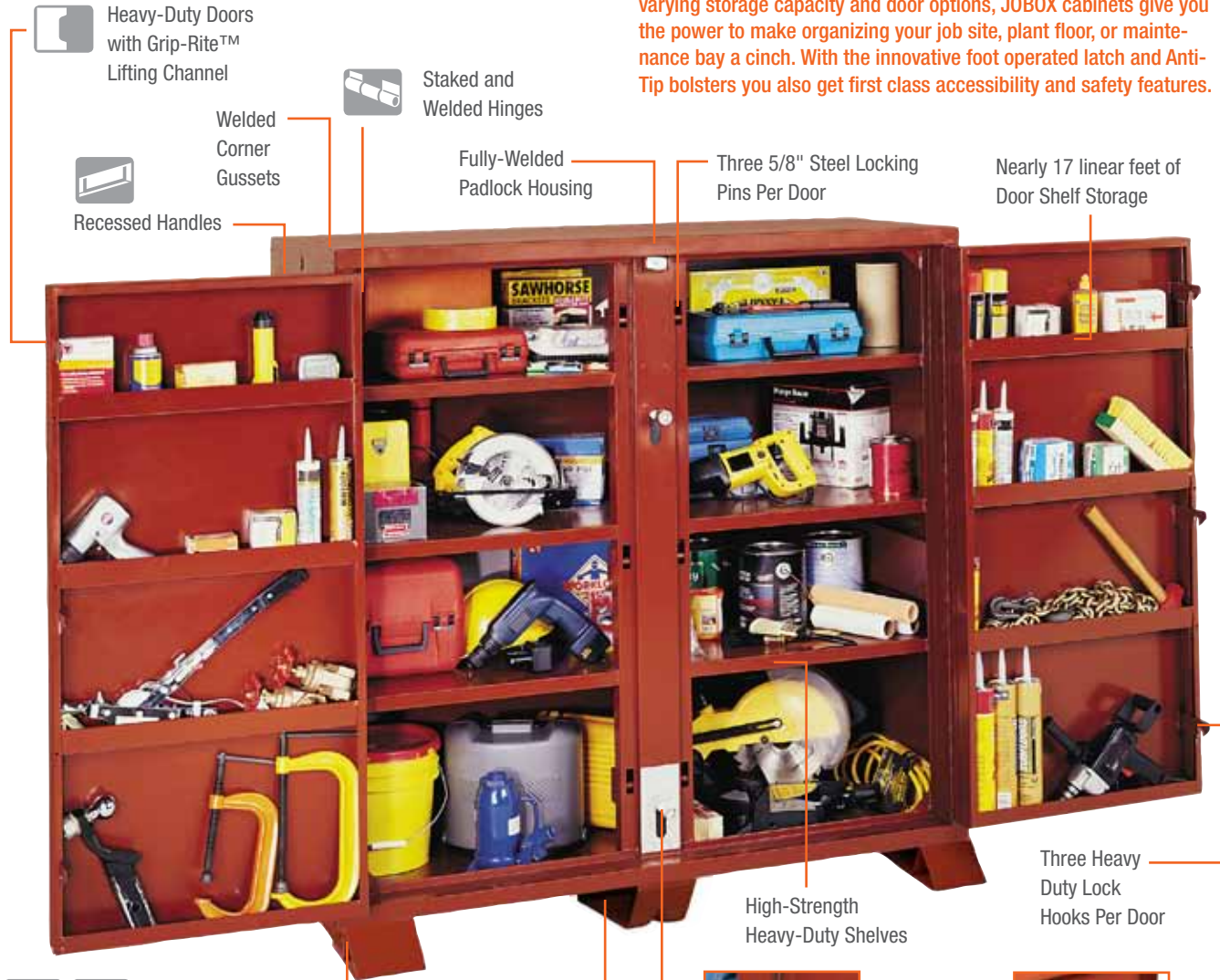

Heavy-Duty Doors with Grip-Rite™ Lifting Channel

Staked and Welded Hinges

Welded Corner Gussets  
Recessed Handles

Fully-Welded Padlock Housing

Three 5/8" Steel Locking Pins Per Door

Nearly 17 linear feet of Door Shelf Storage

High-Strength Heavy-Duty Shelves

Three Heavy Duty Lock Hooks Per Door



- Side EZ-Loader® Anti-Tip Skid Bolsters
- Center EZ-Loader® Skid Bolster
- Formed-In Reinforcements Strengthen Skid Bolsters
- 7-Gauge, One-Piece Steel Bolsters with Holes to install Optional Casters



Hand or Foot Operated Door Latch Release System



Access Holes for Electrical Cables

Cat. No.	Description	Length	Width	Height	Usable Cu. Ft.	Shipping Cu. Ft.	App. Ship Wt.
1-694990	Two Doors	60.75 in	24.25 in	60.25 in	47.5 ft³	53.2 ft³	379.00 lb
1-695990	Four Doors, Both Sides	60.13 in	32.25 in	60.75 in	63.7 ft³	66.5 ft³	523.00 lb
1-697990	Two Doors, Open Side	60.13 in	24.25 in	60.75 in	47.5 ft³	53.2 ft³	366.00 lb
1-698990	Two Doors	60.13 in	30.25 in	60.75 in	58.7 ft³	62.5 ft³	436.00 lb

# DRAWER CABINET



JOBBOX Drawer Cabinets offer the same security and accessibility features as our Heavy-Duty Cabinets, but with fully extendable High-Load Capacity Drawers for added storage options.



Staked and Welded Hinges

Welded Corner Gussets



Access Holes for Electrical Cables



Recessed Handles



Heavy-Duty Doors with Grip-Rite™ Lifting Channel

Three Heavy Duty Lock Hooks Per Door



- Side EZ-Loader® Anti-Tip Skid Bolsters
- Center EZ-Loader® Skid Bolster
- Formed-In Reinforcements Strengthen Skid Bolsters
- 7-Gauge, One-Piece Steel Bolsters with Holes to install Optional Casters

Fully Welded Padlock Housing

Three 5/8" Steel Locking Pins Per Door

2.5" Drawers Have 75Lb. Load Capacity and 5.5" Drawers Have 125Lb. Load Capacity.

Drawers Fully Extend for Easy Access

Nearly 17 linear feet of Door Shelf Storage



Hand or Foot Operated Door Latch Release System

High-Strength Heavy-Duty Shelves

**SEE THE VIDEO**



Cat. No.	A	B	C	D	E	Usable Cu. Ft.	Shipping Cu. Ft.	App. Ship Wt.
1-679990	60-3/4 in	60-1/8 in	30-1/4 in	53-1/4 in	25-3/4 in	58.7 ft³	62.5 ft³	610.00 lb

# EXTRA-HEAVY DUTY BIN CABINET



Touting a massive 49 cu. ft. storage capacity, the Extra-Heavy Duty Bin cabinet has no equal in modifiable organization solutions. Dividers can be moved in as little as 2" increments or removed to create various sized bins. Perfect for organization of tools, personal equipment, safety materials and more.

\*612990 - Optional Handles available for separate purchase



Heavy-Duty Doors with Grip-Rite™ Lifting Channel



Staked and Welded Hinges



Welded Corner Gussets

Fully-Welded Padlock Housing

Three 5/8" Steel Locking Pins Per Door

High-Strength Heavy-Duty Shelves

Three Heavy Duty Lock Hooks Per Door

Over 40' of Shelving Built Into Doors for Holding Smaller Items



Hand or Foot Operated Door Latch Release System



Access Holes for Electrical Cables

Heavy Duty Galvanized Movable Bin Dividers

Dividers Can Be Moved in 2" Increments or Removed to Create Various Size Bins



- Side EZ-Loader® Anti-Tip Skid Bolsters
- Center EZ-Loader® Skid Bolster
- Formed-In Reinforcements Strengthen Skid Bolsters
- 7-Gauge, One-Piece Steel Bolsters with Holes to install Optional Casters

Cat. No.	Length	Width	Height	Usable Cu. Ft.	Shipping Cu. Ft.	App. Ship Wt.
1-693990	72 in	24 in	61 in	49 ft³	59.1 ft³	522.00 lb



# ROLLING CLAM SHELL CABINET



The JOBBOX Clam Shell Cabinet offers an easy to move storage solution with optimal organization and security options. 10-Gauge specially designed latching hasp prevents pry bars and cutting tools from accessing the cabinet. Moveable top and bottom shelves, open storage closet, and lockable storage areas are all included in the versatile Clam Shell cabinet.



Welded Corner Gussets

Rugged 16-Gauge Steel Construction



- Staked and Welded Hinge
- Hinge Stop Prevents Cabinet From Fully Opening and Reduces Potential for Tipping

High Center Handles for Opening, Closing, and Moving Cabinet

Internal Storage Locker



Eight 4" Heavy-Duty Casters

Moveable Top and Bottom Shelves

Open Storage Closet for Tall Items



Only Key Entry Area of Padlock is Exposed

10-Gauge Latching Hasp

Cat. No.	Length	Width	Height	Usable Cu. Ft.	Shipping Cu. Ft.	App. Ship Wt.
692990	62.25 in	30 in	63.5 in	58 ft <sup>3</sup>	72 ft <sup>3</sup>	472.00 lb

# ROLLING WORK BENCHES

SEE THE  
▶ VIDEO



For the ultimate in portability and accessibility, the Rolling Work Bench provides superior strength casters, shelving and drawers to meet the most arduous working environment demands. Users can arrange the Rolling Work Bench into four unique configurations to meet their particular storage needs.

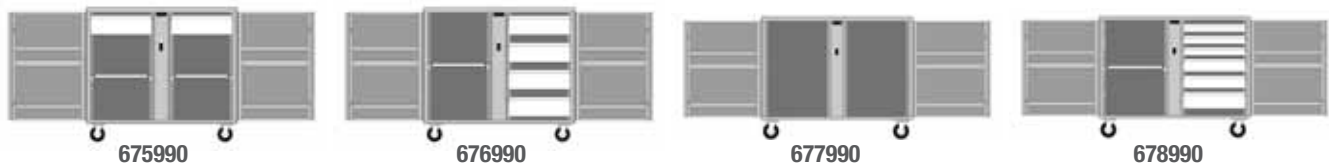

Cat. No.	Description	Length	Width	Height	Usable Cu. Ft.	Shipping Cu. Ft.	App. Ship Wt.
675990	2 Drawers, 2 Shelves, 4" Casters	43.88 in	26.88 in	38.5 in	21.7 ft <sup>3</sup>	24.8 ft <sup>3</sup>	267.00 lb
675996	2 Drawers, 2 Shelves, 6" Casters	43.88 in	26.88 in	40.5 in	21.7 ft <sup>3</sup>	24.8 ft <sup>3</sup>	280.00 lb
676990	4 Drawers, 1 Shelf, 4" Casters	43.88 in	26.88 in	38.5 in	21.7 ft <sup>3</sup>	224.8 ft <sup>3</sup>	294.00 lb
676996	4 Drawers, 1 Shelf, 6" Casters	43.88 in	26.88 in	40.5 in	21.7 ft <sup>3</sup>	24.8 ft <sup>3</sup>	307.00 lb
677990	Body with 6" Casters, Add Drawers & Shelves	43.88 in	26.88 in	40.63 in	24.6 ft <sup>3</sup>	28.1 ft <sup>3</sup>	264.00 lb
678990	6 Drawers, 1 Shelf, 6" Casters	43.88 in	26.88 in	40.63 in	24.6 ft <sup>3</sup>	28.1 ft <sup>3</sup>	342.00 lb

# WELDER'S BOX & SMALL CHESTS



Smart and designed to get the job done. With features like cutouts for tools connected to supply hoses on our Welder's Boxes, and bolt-cutter-proof lock housings on our Small Chests, JOBOX has offers essential storage staples for workers on the go.

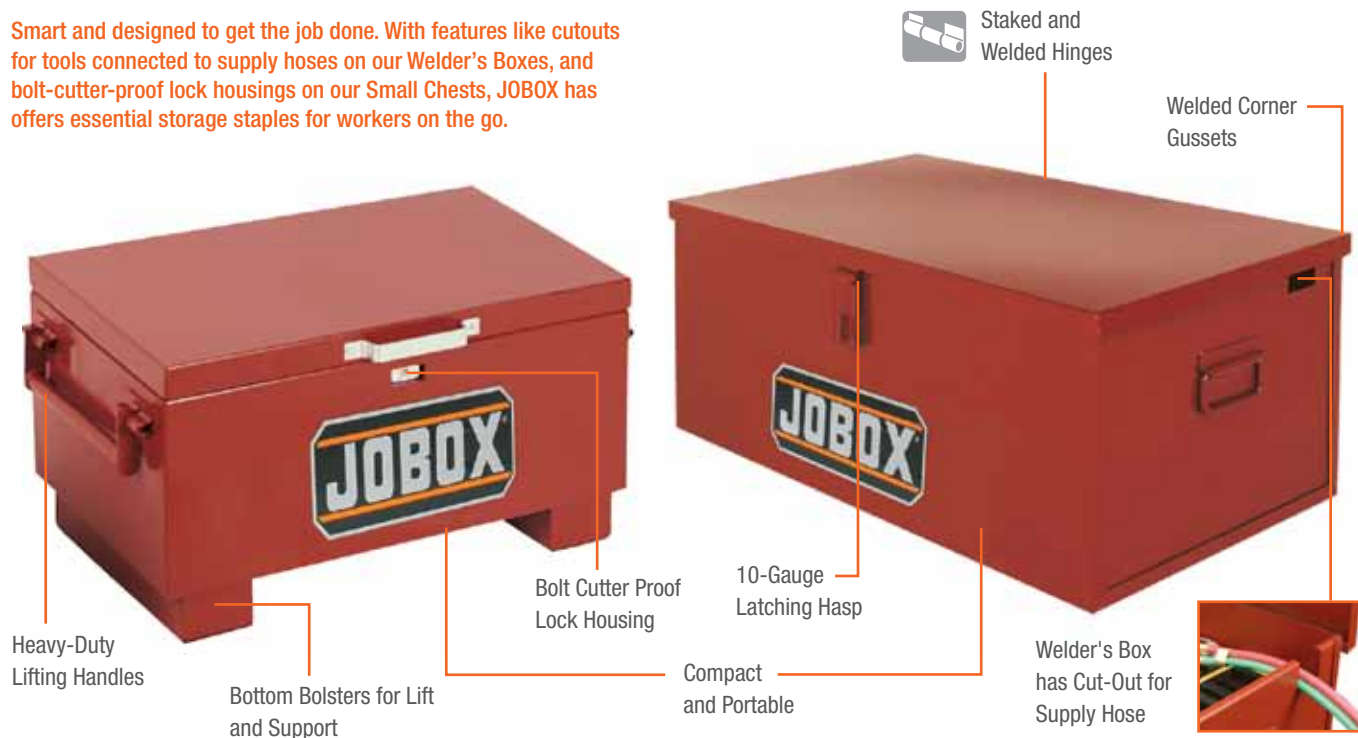

Cat. No.	Description	Length	Width	Height	Usable Cu. Ft.	Shipping Cu. Ft.	App. Ship Wt.
650990	Welder's Box	30 in	16 in	12 in	3.3 ft <sup>3</sup>	4.6 ft <sup>3</sup>	33.00 lb
651990	Embedded Lock	31 in	18 in	15.5 in	4 ft <sup>3</sup>	5.7 ft <sup>3</sup>	70.00 lb
659990	Hasp Lock	30 in	16 in	12 in	3.3 ft <sup>3</sup>	4.6 ft <sup>3</sup>	33.00 lb

## REPLACEMENT DRAWERS, SHELF, & HANDLE FOR ROLLING WORK BENCHES



■ 18 Gauge Steel Drawers have heavy-duty ball bearing glides

Cat. No.	Description	Used On
604990	Shelf	Models 675 & 676
608990	Shelf	Models 677 & 678
605990	2-1/2" Deep Drawer	Models 675 & 676
609990	2-1/2" Deep Drawer	Models 677 & 678
606990	4-1/2" Deep Drawer	Models 675 & 676
610990	4-1/2" Deep Drawer	Models 677 & 678
607990	5-1/2" Deep Drawer	Models 675 & 676
611990	5-1/2" Deep Drawer	Models 677 & 678
616990	10" Deep Drawer	Models 675 & 676
617990	10" Deep Drawer	Models 677 & 678
612990	Optional 2nd Push Handle	Models 675 & 676

## ON-SITE STORAGE ACCESSORIES

### OPTIONAL CASTERS



- Available in Heavy-Duty and Semi-Pneumatic
- Set of 4 Casters comes with two fixed and two swivel casters
- Semi-Pneumatic Swivel Casters include wheel lock to prevent roll
- Wheels never puncture or go flat
- All Purpose Rubber Tread for grip on many surfaces
- 3" x 3" Hole Patterns

Cat. No.	Size	Style	Load Rating	App. Ship Wt.
1-320990	4 in	HD	2800 lb	15.0 lb
1-321990	6 in	HD	3600 lb	19.0 lb
1-324990	8 in	S-P	2000 lb	31.0 lb

### REMOVABLE TRAYS



- Built-In Handles for Storing Small Parts or Tools
- Hemmed Edges add Strength and Eliminate Sharp Edges

Cat. No.	Length	Width	Height	Used On
624990D	16-3/16 in	8 in	4 in	JOBBOX: 651990
626990	22-3/16 in	8 in	4 in	JOBBOX: 1-654990, 1-655990, 1-658990
627990	28-3/16 in	8 in	4 in	JOBBOX: 1-656990
628990	18-3/16 in	8 in	4 in	JOBBOX: 1-652990, 1-653990

### REPLACEMENT FASTENER KITS

Cat. No.	UPC No.	Used On
10318-410	043419927223	635990, 636990, 637990, 638990, 639990, 648990
10318-411	043419938243	675990, 676990, 677990, 678990
10318-412	043419938250	1-669990, 1-674990, 1-679990, 1-693990, 1-694990, 1-695990, 1-697990, 1-698990
10318-415		692990
10318-416	043419932463	651990
10318-705	043419938311	1-652990, 1-653990, 1-654990, 1-655990, 1-656990, 1-657990, 1-658990, 1-680990, 1-681990, 1-682990, 1-683990, 1-684990, 1-685990, 1-688990, 1-689990

### TOUCH UP PAINT



- Available in 12 oz Cans

Cat. No.	UPC No.	Used On
82936	043419942240	All JOBBOX Models

# SAFETY STORAGE



# SAFETY STORAGE

( PREMIUM FEATURES )



## JOBBOX SAFETY STORAGE

The innovative features of JOBBOX safety cabinets and cans make flammable liquids storage compliance easier.

SEE THE  
▶ VIDEO



## EZ-LEVEL™

### SKID BOLSTERS



- Leveling Screw Access Hole provides quick and easy access
- Unique Anti-tip Design extends the base foot print beyond the width of the cabinet for maximum stability and tipping resistance
- 7-Gauge Steel Construction
- Fork Lift and Pallet Jack Ready for increased mobility and easy cleaning underneath the cabinet.

SEE THE  
▶ VIDEO



### SELF-CLOSING SYSTEM



- Self-Latching 3-Point Door Lock System
- Heavy-Duty Enclosed Staggering Mechanism ensures doors close in proper order
- Stainless Steel Slam Latches
- Heavy-Duty Chain holds doors open during work
- Fusible Chain Link shears at 165°F to close doors



[www.safety.jobox.com](http://www.safety.jobox.com)

# SAFETY STORAGE

◀ PREMIUM FEATURES ▶

## HI-VIZ SAFETY LABELS



- Safety and Warning Labels provide permanent reminder and reference for users to follow proper safety and usage practices
- Sharp Contrasting Colors for high visibility



## EXTRA-WIDE DOORS



- 2.5" Thick Doors provide greater insulation gap between metal panels for added durability and safety



## BRIGHT WHITE INTERIOR



- Maximum Visibility in low light conditions, allowing users to quickly and safely identify cabinet contents



## STAKED HINGES



- 14-Gauge Steel
- 3/8" Staked, Continuous Hinge with 1/4" steel pin and extra-large 1" knuckles
- Pin cannot be driven out for added security



## SPILL GUIDE SHELVING



- Safety Cabinet Shelves gently guide spills
- Liquids are guided toward the 2" deep leak-proof sump for easy clean-up



## TEXTURED POWDER PAINT FINISH



- High-Quality Powder Paint improves durability over liquid paint

**10x**

corrosion resistance

**5x**

abrasion resistance

**2x**

chip resistance

**2x**

scratch resistance

Available in the Following Industry Standard Color Options

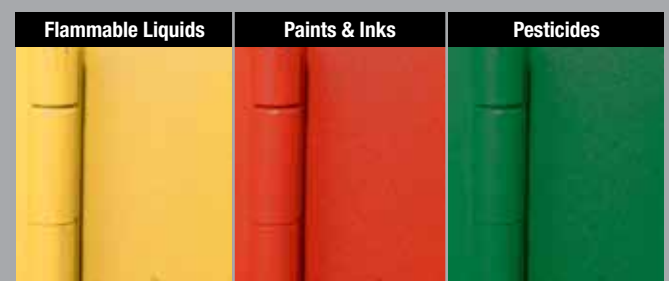

## SAFETY COMPLIANCE

JOBX cabinets and cans comply with all applicable specifications set forth by the Occupational Safety and Health Administration (OSHA) and the National Fire Protection Association (NFPA). JOBX self-closing cabinets also comply with the International Code Consortium/International Fire Code (IFC). Compliance to these specifications has been independently tested and listed by Underwriters Laboratories (UL) the internationally recognized third-party testing organization.

### SAFETY CANS



- NFPA Compliant Container for Storage of Kerosene (Blue can) or Diesel (Yellow can)
- NFPA Compliant Container for Storage of Gasoline (Red can)
- Specified by the Safety Professional ~ Required by OSHA in the Workplace
- Meets ASTM F839/F926

### SAFETY CABINETS



- Specified by the Safety Professional ~ Required by OSHA in the Workplace
- Meets requirements of OSHA 29 CFR 1910.106
- Meets requirements of NFPA 30

### SELF-CLOSING SAFETY CABINETS



- Specified by the Safety Professional ~ Required by OSHA in the Workplace
- Meets requirements of OSHA 29 CFR 1910.106
- IFC Compliant
- Meets requirements of NFPA 30

# HEAVY-DUTY SAFETY CABINETS, YELLOW



Keep flammable liquids organized, secure, and protected from fire with UL listed JOBBOX® safety cabinets. With exclusive features like EZ Level™ bolsters, permanent safety labels, and white interiors, these cabinets offer improved safety with the security and durability JOBBOX storage products are known for.



Hi-Viz Safety Labels



- Spill Guide Shelving
- 2" Leak-Proof Sump



Adjustable Shelving

3-Point Door Lock System



- EZ-Level™ Skid Bolsters
- Leveling-Screw Access Hole
- Unique Anti-tip Safety Bolster
- Forklift and Pallet Jack Accessible



High / Low Vent Connections



Staked Hinges



Extra-Wide 2.5" Doors

Pad-Lockable Paddle Handle

18-Gauge Double Wall Construction



Bright White Interior for Improved Visibility

Available in 12, 30, 45, 60 and 90 Gallon sizes



- Textured Powder Paint Finish
- Yellow: Flammable Liquid Storage



Cat. No.	Capacity	Exterior Dimensions H x W x D	Interior Dimensions H x W x D	No. of Doors	No. of Spill Guide Shelves	Compliance / Listings	App. Ship Wt.
1-850990	12 gal (US), 45 l	35.50 x 30.13 x 19.69	32.31 x 26.63 x 16.17	1	1	UL, NFPA, OSHA,	146 lb
1-853990	30 gal (US), 113.5 l	49 x 46.09 x 19.63	39.94 x 42.38 x 14.75	2	1	UL, NFPA, OSHA,	257 lb
1-856990	45 gal (US), 170 l	67.25 x 46.88 x 21.25	57.91 x 45.47 x 14.78	2	2	UL, NFPA, OSHA,	336 lb
1-858990	60 gal (US), 227 l	67.25 x 46.15 x 26.28	57.94 x 42.44 x 21.81	2	2	UL, NFPA, OSHA,	400 lb
1-859990	90 gal (US), 340.6 l	67.28 x 46.90 x 31.59	57.94 x 42.44 x 26.81	2	2	UL, NFPA, OSHA,	460 lb



## HEAVY-DUTY SAFETY CABINETS, RED



JOBBOX® Red safety cabinets offer the same storage and security features as the yellow cabinets, but are industry standard red for storage of paints, inks, and other combustibles.

- 3-Point Door Lock System
- Industry First Hi-Viz Grounding, Venting, and Secondary Safety Labels
- EZ-Level™ Skid Bolsters offer Leveling-Screw Access Hole and unique anti-tip shape
- High / Low Vent Connections
- Bright White Interior for better visibility
- Spill Guide Shelving for improved spill containment and clean-up
- Pad-Lockable Paddle Handles
- Extra-Wide 2.5" Doors



Cat. No.	Capacity	Exterior Dimensions H x W x D	Interior Dimensions H x W x D	No. of Doors	No. of Spill Guide Shelves	Compliance / Listings	App. Ship Wt.
1-850610	12 gal (US), 45 l	35.50 x 30.13 x 19.69	32.31 x 26.63 x 16.17	1	1	UL, NFPA, OSHA,	146 lb
1-853610	30 gal (US), 113.5 l	49 x 46.09 x 19.63	39.94 x 42.38 x 14.75	2	1	UL, NFPA, OSHA,	257 lb
1-856610	45 gal (US), 170 l	67.25 x 46.88 x 21.25	57.91 x 45.47 x 14.78	2	2	UL, NFPA, OSHA,	336 lb
1-858610	60 gal (US), 227 l	67.25 x 46.15 x 26.28	57.94 x 42.44 x 21.81	2	2	UL, NFPA, OSHA,	400 lb
1-859610	90 gal (US), 340.6 l	67.28 x 46.90 x 31.59	57.94 x 42.44 x 26.81	2	2	UL, NFPA, OSHA,	460 lb

## HEAVY-DUTY SAFETY CABINETS, GREEN



JOBBOX® Green safety cabinets offer the same storage and security features as the yellow cabinets, but are industry standard green for storage of outdoor chemicals.

- 3-Point Door Lock System
- Industry First Hi-Viz Grounding, Venting, and Secondary Safety Labels
- EZ-Level™ Skid Bolsters offer Leveling-Screw Access Hole and unique anti-tip shape
- High / Low Vent Connections
- Bright White Interior for better visibility
- Spill Guide Shelving for improved spill containment and clean-up
- Pad-Lockable Paddle Handles
- Extra-Wide 2.5" Doors



Cat. No.	Capacity	Exterior Dimensions H x W x D	Interior Dimensions H x W x D	No. of Doors	No. of Spill Guide Shelves	Compliance / Listings	App. Ship Wt.
1-850670	12 gal (US), 45 l	35.50 x 30.13 x 19.69	32.31 x 26.63 x 16.17	1	1	UL, NFPA, OSHA,	146 lb
1-853670	30 gal (US), 113.5 l	49 x 46.09 x 19.63	39.94 x 42.38 x 14.75	2	1	UL, NFPA, OSHA,	257 lb
1-856670	45 gal (US), 170 l	67.25 x 46.88 x 21.25	57.91 x 45.47 x 14.78	2	2	UL, NFPA, OSHA,	336 lb
1-858670	60 gal (US), 227 l	67.25 x 46.15 x 26.28	57.94 x 42.44 x 21.81	2	2	UL, NFPA, OSHA,	400 lb
1-859670	90 gal (US), 340.6 l	67.28 x 46.90 x 31.59	57.94 x 42.44 x 26.81	2	2	UL, NFPA, OSHA,	460 lb

# SELF-CLOSING SAFETY CABINETS, YELLOW



- Self-Closing 3-Point Door Lock System
- Heavy-Duty Enclosed Staggering Mechanism
- Heavy-Duty Chain holds doors open during work
- Fusible Chain Link shears at 165°F to close doors

With JOBBOX® self-closing cabinets, users can work freely with peace of mind knowing that their flammable liquids will be secure. Extra-robust fusible link system will operate at 165°F to close the doors, and a heavy-duty, galvanized staggering mechanism ensures the doors close securely in the event of a fire. Fully-enclosed, the JOBBOX® self-closing system ensures safe operation while offering maximum storage space inside the cabinet.



Hi-Viz Safety Labels



- Spill Guide Shelving
- 2" Deep Leak-Proof Sump



Adjustable Shelving



- EZ-Level™ Skid Bolsters
- Leveling-Screw Access Hole
- Unique Anti-tip Safety Bolster
- Forklift and Pallet Jack Accessible



High / Low Vent Connections



Staked Hinges



Extra-Wide 2.5" Doors

Pad-Lockable Paddle Handle

18-Gauge Double Wall Construction



Bright White Interior for Improved Visibility



- Textured Powder Paint Finish
- Yellow: Flammable Liquid Storage



Cat. No.	Capacity	Exterior Dimensions H x W x D	Interior Dimensions H x W x D	No. of Doors	No. of Spill Guide Shelves	Compliance / Listings	App. Ship Wt.
1-854990	30 gal (US), 113.5 l	49 x 46.09 x 19.63	39.94 x 42.38 x 14.75	2	1	UL, NFPA, OSHA, IFC	260 lb
1-857990	45 gal (US), 170 l	67.25 x 46.88 x 21.25	57.91 x 45.47 x 14.78	2	2	UL, NFPA, OSHA, IFC	339 lb

## SELF-CLOSING SAFETY CABINETS, RED



JOBBOX® Red self-closing safety cabinets offer the same storage and security features as the yellow cabinets, but are industry standard red for storage of paints, inks, and other combustibles.

- Self-Closing 3-Point Door Lock System
- Heavy-Duty Enclosed Staggering Mechanism
- Heavy-Duty Chain holds doors open during work, Fusible Chain Link shears at 165°F to close doors
- Industry First Hi-Viz Grounding, Venting, and Secondary Safety Labels
- EZ-Level™ Skid Bolsters offer Leveling-Screw Access Hole and unique anti-tip shape
- High / Low Vent Connections
- Bright White Interior for better visibility
- Spill Guide Shelving for improved spill containment and clean-up



Cat. No.	Capacity	Exterior Dimensions H x W x D	Interior Dimensions H x W x D	No. of Doors	No. of Spill Guide Shelves	Compliance / Listings	App. Ship Wt.
1-854610	30 gal (US), 113.5 l	49 x 46.09 x 19.63	39.94 x 42.38 x 14.75	2	1	UL, NFPA, OSHA, IFC	260 lb
1-857610	45 gal (US), 170 l	67.25 x 46.88 x 21.25	57.91 x 45.47 x 14.78	2	2	UL, NFPA, OSHA, IFC	339 lb

## SELF-CLOSING SAFETY CABINETS, GREEN



JOBBOX® Green self-closing safety cabinets offer the same storage and security features as the yellow cabinets, but are industry standard green for storage of outdoor chemicals.

- Self-Closing 3-Point Door Lock System
- Heavy-Duty Enclosed Staggering Mechanism
- Heavy-Duty Chain holds doors open during work, Fusible Chain Link shears at 165°F to close doors
- Industry First Hi-Viz Grounding, Venting, and Secondary Safety Labels
- EZ-Level™ Skid Bolsters offer Leveling-Screw Access Hole and unique anti-tip shape
- High / Low Vent Connections
- Bright White Interior for better visibility
- Spill Guide Shelving for improved spill containment and clean-up



Cat. No.	Capacity	Exterior Dimensions H x W x D	Interior Dimensions H x W x D	No. of Doors	No. of Spill Guide Shelves	Compliance / Listings	App. Ship Wt.
1-854670	30 gal (US), 113.5 l	49 x 46.09 x 19.63	39.94 x 42.38 x 14.75	2	1	UL, NFPA, OSHA, IFC	260 lb
1-857670	45 gal (US), 170 l	67.25 x 46.88 x 21.25	57.91 x 45.47 x 14.78	2	2	UL, NFPA, OSHA, IFC	339 lb



RED: Gasoline, Flammable Liquids

Cat. No.	Type	Capacity	Dia. (in) x Hose L	Compliance / Listings	App. Ship Wt.
<b>Red - Flammable - Canister</b>					
811990	Type I	1 gal (US), 4 l	9 x 6	UL/ULC/OSHA/NFPA	5 lb
811990F*	Type I	1 gal (US), 4 l	9 x 6	UL/ULC/OSHA/NFPA	5 lb
812990	Type I	2 gal (US), 7.5 l	9 x 6	UL/ULC/OSHA/NFPA	6 lb
812990F*	Type I	2 gal (US), 7.5 l	9 x 6	UL/ULC/OSHA/NFPA	6 lb
815990	Type I	5 gal (US), 19 l	11.5 x 9	UL/ULC/OSHA/NFPA	9 lb
815990F*	Type I	5 gal (US), 19 l	11.5 x 9	UL/ULC/OSHA/NFPA	9 lb

\* Funnel Included

## TYPE I CANISTERS FOR FLAMMABLE LIQUIDS

JOBBOX® Type I cans are made of resilient terne plate steel for the ultimate in corrosion resistance. They have one opening and recommended for storage, but can be used with a funnel for pouring into other containers. Stringently UL and ULC tested and listed.



BLUE: Kerosene YELLOW: Diesel

5 YR. LIMITED WARRANTY

Cat. No.	Type	Capacity	Dia. (in) x Hose L	Compliance / Listings	App. Ship Wt.
<b>Yellow - Diesel - Canister</b>					
811990Y	Type I	1 gal (US), 4 l	9 x 6	UL/ULC/OSHA/NFPA	5 lb
812990Y	Type I	2 gal (US), 7.5 l	9 x 6	UL/ULC/OSHA/NFPA	6 lb
815990Y	Type I	5 gal (US), 19 l	11.5 x 9	UL/ULC/OSHA/NFPA	9 lb
<b>Blue - Kerosine - Canisters</b>					
811990B	Type I	1 gal (US), 4 l	9 x 6	UL/ULC/OSHA/NFPA	5 lb
812990B	Type I	2 gal (US), 7.5 l	9 x 6	UL/ULC/OSHA/NFPA	6 lb
815990B	Type I	5 gal (US), 19 l	11.5 x 9	UL/ULC/OSHA/NFPA	9 lb



RED: Gasoline, Flammable Liquids

Cat. No.	Type	Capacity	Dia. (in) x Hose L	Compliance / Listings	App. Ship Wt.
<b>Red - Flammable - Canister</b>					
821990	Type II	1 gal (US), 4 l	9 x 6	UL/ULC/OSHA/NFPA	7 lb
822990	Type II	2 gal (US), 7.5 l	9 x 6	UL/ULC/OSHA/NFPA	8.5 lb
825990	Type II	5 gal (US), 19 l	11.5 x 9	UL/ULC/OSHA/NFPA	12 lb

## TYPE II CANISTERS FOR FLAMMABLE LIQUIDS

Designed for pouring flammable liquids. Type II cans offer two openings, one for fill and one for pour. Brass tipped pouring hose prevents sparking, and special implosion resistance system ensures a safe pour every time. Stringently UL and ULC Tested and Listed.



BLUE: Kerosene YELLOW: Diesel

5 YR. LIMITED WARRANTY

Cat. No.	Type	Capacity	Dia. (in) x Hose L	Compliance / Listings	App. Ship Wt.
<b>Yellow - Diesel - Canister</b>					
821990Y	Type II	1 gal (US), 4 l	9 x 6	UL/ULC/OSHA/NFPA	7 lb
822990Y	Type II	2 gal (US), 7.5 l	9 x 6	UL/ULC/OSHA/NFPA	8.5 lb
825990Y	Type II	5 gal (US), 19 l	11.5 x 9	UL/ULC/OSHA/NFPA	12 lb
<b>Blue - Kerosine - Canisters</b>					
821990B	Type II	1 gal (US), 4 l	9 x 6	UL/ULC/OSHA/NFPA	7 lb
822990B	Type II	2 gal (US), 7.5 l	9 x 6	UL/ULC/OSHA/NFPA	8.5 lb
825990B	Type II	5 gal (US), 19 l	11.5 x 9	UL/ULC/OSHA/NFPA	12 lb

# TRUCK STORAGE



《 CROSSOVERS, INNERSIDES, & LADDER RACKS 》

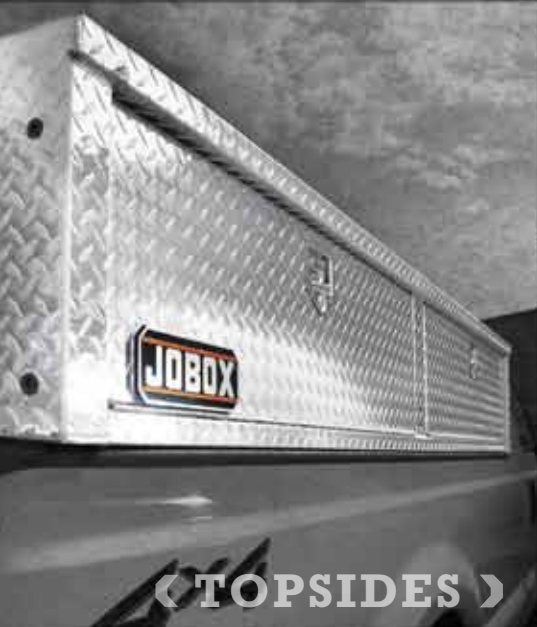

《 TOPSIDES 》

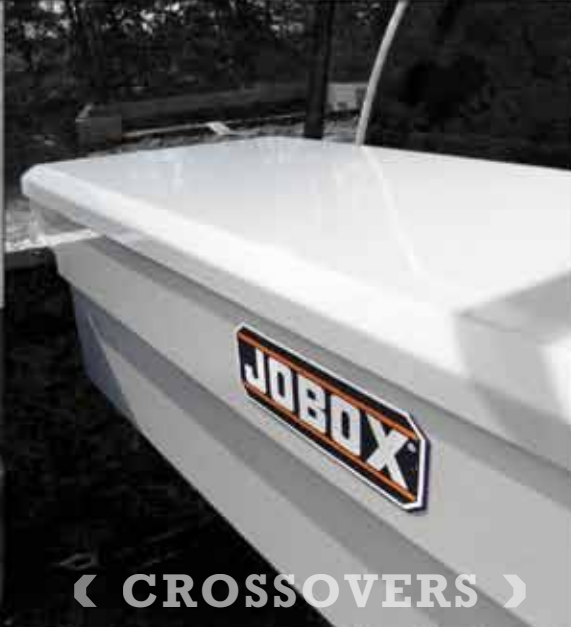

《 CROSSOVERS 》



《 UNDERBEDS 》



《 TRANSFER TANKS 》



《 DRAWER STORAGE 》

# TRUCK STORAGE

◀ PREMIUM FEATURES ▶



## JOBBOX TRUCK STORAGE

Versatile, tough, and secure, JOBBOX truck boxes, drawer systems, ladder racks, and transfer tanks offer the best in mobile storage solutions.

## CROSSOVERS, INNERSIDES, & CHESTS

### GEAR-LOCK II™ LOCKING SYSTEM

- Self-adjusting dual rotary lock system
- Ratcheting action pulls lid tight to resist over 2,000 lb. of prying and pulling force
- Provides the highest level of security and moisture resistance available



SEE THE  
▶ VIDEO



### SELF-ALIGNING LATCH HOOPS

- Cannot be bent or pried out of the lock
- Hoops pivot from side-to-side to automatically align in the Gear-Lock II System
- Guarantees a tight seal first time-every time



### HEAVY-DUTY GAS SPRINGS

- Provide easy lifting of Truck Box Lids



### RSL™ DEEP BEVELED EDGE LID

- RSL Rigid Structural Lid Three-Layer Lid has an inner core of rigid foam and reverse beveled liner for superior strength and rigidity
- Creates superior moisture protection and security for your cargo

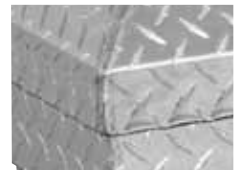

# TRUCK STORAGE

◀ PREMIUM FEATURES ▶

## TOPSIDES & UNDERBED BOXES

### DRILL-RESISTANT PUSH BUTTON LOCK

- Provides easy open unlock action
- Creates superior moisture protection and security for your cargo



### HIGH-STRENGTH DOOR CABLES

- High-Strength, Coated, Galvanized Steel Cable supports 300 lb. load



### THREE-POINT LOCKING SYSTEM

- Doors lock at top and both sides to resist break-ins
- Covers protect the locking system and reinforce the high-strength doors



### BULB-SHAPED WEATHER STRIPPING

- Surrounds door or lid to seal out moisture and dust, keeping contents and box protected

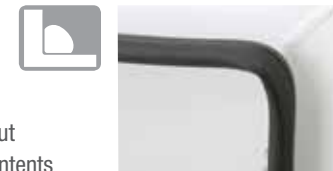

### ROTATING T-HANDLE

- T-Handles have reinforced cam locks and are sealed to prevent moisture from getting inside



## JOBBOX *StorAll* STEEL DRAWER STORAGE

### GRIP-AND-RELEASE™ DRAWER STOP SAFETY SYSTEM

- Release handle and the drawer safely locks into position
- Allows you to safely open and close heavy drawers on sloped surfaces



### UP TO 50% MORE DRAWER WEIGHT CAPACITY

- 650lb drawer weight capacity
- Drawer travels on 1,000 lb. rated rear roller bearings and 250 lb. rated front conveyor bearings
- 12-Gauge steel channels





### UP TO 20% MORE STORAGE CAPACITY

- Both Front-to-Rear sectional dividers and bin dividers are adjustable
- Customizable storage



# ALUMINUM SINGLE LID CROSSOVERS



-  High-Strength Deep Beveled Edge Lid
-  Full-Length Lid Bolster Reinforcements
-  RSL™ Three-Layer Rigid Structural Lid

The ultimate in truck storage security and capacity. Single lid provides best access to entire inside of box and more easily accommodates large and long items. The Rigid Structure Lid (RSL) has two layers of aluminum joined with rigid foam, plus additional full length bolsters for superior strength and rigidity.



Heavy-Duty Gas Springs for Self-Rising Lid

Heavy-Duty Gas Spring Guards

Adjustable Lid Opening

Lid Opens 90°

Channel Reinforced Front Panel

One-Piece Box Body Construction





Self Aligning Latch Hoops



Bulb-Shaped Automotive Weather Stripping



-  Dual Rotary GearLock II™ Locking System
-  Ratcheting Action Pulls Lid Tight to Resist Prying and Pulling
-  Full Length Lock Console

Lift-Out Storage Tray with Movable Dividers



Drill Resistant Push Button Locks

Small Parts Storage Bins

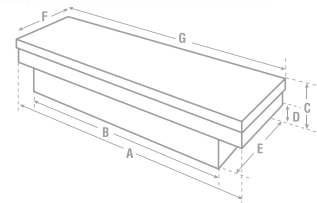

Clearcoat Cat. No.	Black Cat. No.	Size	A	B	C	D	E	F	G	Usable Cu. Ft.	App. Ship Wt.
JAC1379980	JAC1379982	Fullsize Super Deep	70.13 in	60.13 in	21.75 in	14.88 in	20.25 in	21 in	71.88 in	13 ft³	22.1 lb
JAC1387980	JAC1387982	Fullsize Deep	70.13 in	60.13 in	18.88 in	12 in	20.25 in	21 in	72 in	10.7 ft³	17.7 lb
JAC1388980	JAC1388982	Deep Ford Super-Duty & Dodge Ram	73.13 in	63.13 in	18.88 in	12 in	20.25 in	21 in	75 in	12.5 ft³	19.7 lb
JAC1389980	JAC1389982	Fullsize Deep & Extra-Wide	70.13 in	60.13 in	18.88 in	12 in	29.25 in	30 in	72 in	17.5 ft³	26.8 lb
JAC1391980	—	Midsized	63.13 in	52.5 in	15.13 in	8.25 in	20.25 in	21 in	64.13 in	8 ft³	11.5 lb



# ALUMINUM GULL WING CROSSOVERS



The **JOBBOX** gull wing aluminum crossovers offer the best unobstructed access from the sides of your truck. The superior one-piece body construction with a channel-reinforced front panel gives you the toughest box on the market.

SEE THE VIDEO



- Bulb-Shaped Automotive Weather Stripping**
- Self Aligning Latch Hoops**
- RSL™ Three-Layer Rigid Structural Lid**
- High-Strength Deep Beveled Edge Lid**
- Full-Width Lid Bolster Reinforcements**
- Heavy-Duty Gas Springs for Self-Rising Lid**
- Dual Rotary GearLock II™ Locking System**
- Ratcheting Action Pulls Lid Tight to Resist Prying and Pulling**
- Lock Console Protects Lock**
- Small Parts Storage Bins**
- Channel Reinforced Front Panel**
- One-Piece Box Body Construction**
- Lift-Out Storage Tray with Movable Dividers**
- Drill Resistant Push Button Locks**

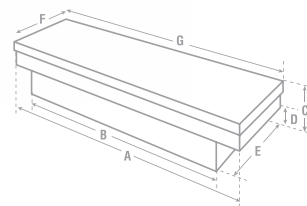

Cat. No.	Size	A	B	C	D	E	F	G	Usable Cu. Ft.	App. Ship Wt.
JAC1392980*	Fullsize Deep	70.13 in	60.13 in	20.5 in	12 in	20.25 in	21 in	72 in	11.7 ft³	19.8 lb
JAC1392982~	Fullsize Deep	70.13 in	60.13 in	20.5 in	12 in	20.25 in	21 in	72 in	11.7 ft³	19.8 lb
JAC1393980*	Compact	6.25 in	50.13 in	14.5 in	7.5 in	20.25 in	21 in	62 in	9.9 ft³	17.2 lb

\* Clearcoat; ~ Black

# STEEL SINGLE LID CROSSOVERS



JOBBOX Steel Crossovers are as tough as they get. Gear-Lock II™ Rotary Lock System self-aligns and ratchets the lid firmly against the weather proof seal, providing resistance to prying and pull force of over 2,000 pounds. Single lid for best access to inside of box and readily accommodates large and long items.



- High-Strength Deep Beveled Edge Lid
- Full-Length Lid Bolster



Heavy-Duty Gas Springs for Self-Rising Lid

Heavy-Duty Gas Spring Guards on Single Lid Models



Lid Opens 90°

Small Parts Storage Bins



Self Aligning Latch Hoops



Bulb-Shaped Automotive Weather Stripping

Adjustable Lid Opening

Channel Reinforced Front Panel



- Dual Rotary GearLock II™ Locking System
- Ratcheting Action Pulls Lid Tight to Resist Prying and Pulling
- Full Length Lock Console



Drill Resistant Push Button Locks

Lift-Out Storage Tray with Movable Dividers

One-Piece Box Body Construction

ArmorBrite™ White Powder Paint Finish

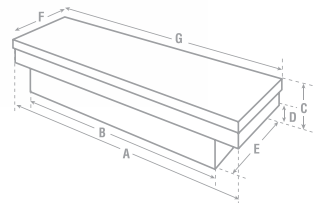

Cat. No.	Size	A	B	C	D	E	F	G	Usable Cu. Ft.	App. Ship Wt.
JSC1394980	Fullsize Deep	70.13 in	60.5 in	18.88 in	12 in	20.25 in	21 in	72 in	10.7 ft³	17.7 lb
JSC1395980	Deep Ford Super-Duty & Dodge Ram	74 in	63 in	18.88 in	12 in	20.25 in	21 in	74.88 in	12.5 ft³	19.7 lb
JSC1396980	Fullsize Deep, Extra-Wide	70.13 in	60.13 in	18.88 in	12 in	29.25 in	30 in	72 in	17.5 ft³	26.8 lb
JSC1397980	Compact	61 in	50 in	12.88 in	6 in	20.25 in	21 in	61.88 in	6.2 ft³	10.9 lb

# STEEL GULL WING CROSSOVER



Gull wing steel crossovers make all your equipment readily accessible at the push of a button and offer clear and unobstructed access from the sides of your truck. Armor-Brite™ powder paint finish provides unparalleled durability and corrosion resistance.

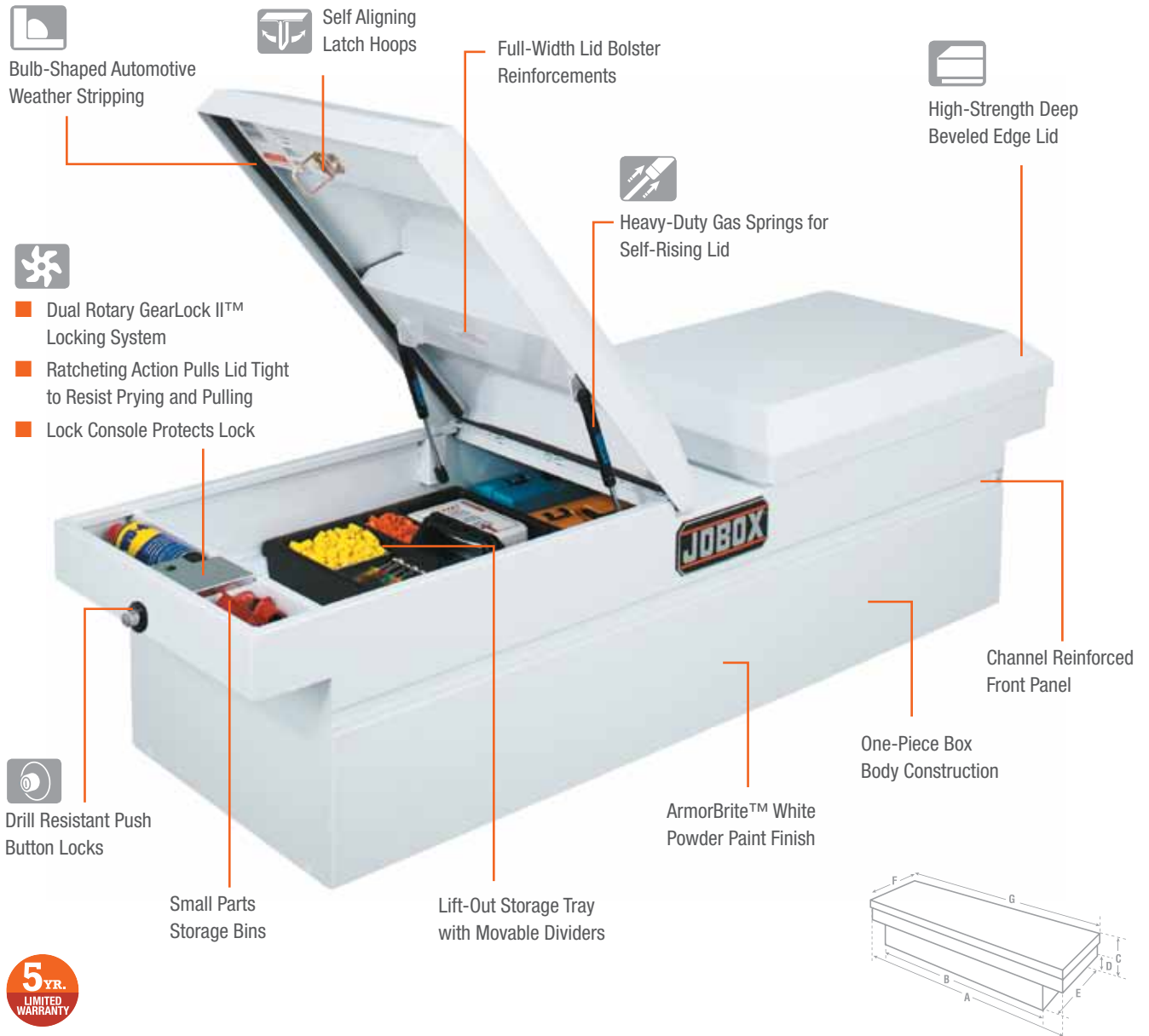

Cat. No.	Size	A	B	C	D	E	F	G	Usable Cu. Ft.	App. Ship Wt.
JSC1464980	Fullsize Deep	70.13 in	60.13 in	20.5 in	12 in	20.25 in	21 in	72 in	11.7 ft³	19.8 lb

		ALUMINUM CROSSOVERS			
		Single Lid Super Deep Fullsize	Single Lid Deep Fullsize	Single Lid Deep Super-Duty & Ram	Single Lid Deep & Extra-Wide Fullsize
		JAC1379980 JAC1379982	JAC1387980 JAC1387982	JAC1388980 JAC1388982	JAC1389980 JAC1389982
Aluminum Bright Finish Model #   Steel White Finish Model # Aluminum Black Finish Model #					
<b>Chevrolet &amp; GMC Trucks</b>					
1978-2011 Silverado/Sierra 1500	Regular Cab with Standard/Long Bed	•	•		•
	Extended Cab with Short Bed	•	•		
2011 Silverado/Sierra 1500	Crew Cab with Short Bed	•	•		
2011 Silverado/Sierra 2500/3500	All Cabs with All Lengths Beds	•	•		•
2002-2011 Colorado/Canyon	Regular Cab with Regular/Extended Cab Bed				
	Extended Cab with Regular/Extended Cab Bed				
2004-2011 Colorado/Canyon	Crew Cab with Crew Cab Bed				
2012-2013 Silverado/Sierra 1500	Regular Cab with Standard/Long Bed	•	•	•	
	Extended Cab with Short Bed	•	•	•	
	Crew Cab with Short Bed	•	•	•	
2012-2013 Silverado/Sierra 2500/3500	Extended Cab with All Lengths Bed	•	•	•	
	Regular/Crew Cab with All Lengths Bed	•	•	•	•
<b>Dodge Trucks</b>					
2011 Ram 1500	Regular Cab with Standard/Long Bed	•	•	•	
	Quad Cab with Standard Bed	•	•	•	
2011 Ram 2500/3500	Regular/Mega/Crew Cab with Standard Bed	•	•	•	
2011 Dakota	Club Cab with Standard Bed				
	Quad Cab with Standard Bed				
2012-2013 Ram 1500	Regular Cab with Long Bed	•	•	•	•
	Regular Cab with Standard Bed				
	Express Quad Cab with Standard/Long Bed				
	Longhorn Crew Cab with Standard Bed				
2012-2013 Ram 2500/3500	Regular/Mega/Crew Cab with Standard Bed				
<b>Ford Trucks</b>					
2007-2011 Explorer	Sport-Trac Cab with Standard Bed				
2011 F-150	Styleside Cab with Short 5.5' Bed		•		•
	Styleside Cab with Standard 6.75' / Long 8' Bed	•	•		•
	Flareside Cab with Standard 6.5' Bed				
2011 F-250, F-350	Styleside Cab with Standard 6.75' / Long 8' Bed	•	•		•
1987-2011 Ranger	Regular Cab with Standard/Long Bed				
2001-2011 Ranger	Super Cab with Standard/Long Bed				
2012-2013 F-150	Regular Cab with Short 5.5' Bed		•		
	Super Cab with Standard 6.5' Bed		•		
	Super Crew Cab with Standard 6.5' Bed				
2012-2013 F-250, F-350	Regular/Crew Cab with Standard 6.75' / Long 8' Bed	•	•	•	
<b>Isuzu Trucks</b>					
2005-2009 i-370	Standard Bed				
1997-2009 I-290	Standard Bed				
<b>Mazda Trucks</b>					
1997-2009 B2300	Standard Cab with Standard Bed				
1997-2009 B4000	Cab Plus 4 with Standard Bed				
<b>Mitsubishi Trucks</b>					
2006-2009 Raider	Extended Cab with Standard Bed				
	Double Cab with Standard Bed				
<b>Nissan Trucks</b>					
2011 Titan	Crew Cab with Standard/Long Bed	•	•	•	•
	King Cab with Standard/Long Bed		•		•
2005-2011 Frontier	Crew/King Cab with Standard/Long Bed				
2012-2013 Titan	KC 4X2 Cab with Standard/Long Bed	•	•		
	Crew/King Cab with Standard/Long Bed				
2012-2013 Frontier	Crew/King Cab with Standard/Long Bed				
<b>Toyota Trucks</b>					
2007-2011 Tundra	Regular/Double Cab with Standard/Long Bed	•	•		•
	CrewMax Cab with Standard Bed		•		•
2012-2013 Tundra	Regular/CrewMax Cab with Standard Bed		•		
	Double Cab with Standard Bed	•	•		
1989-2004 Tacoma	Regular Cab with Standard Bed				
2005-2011 Tacoma	Regular Cab with Standard Bed				
	Access Cab with Standard Bed				
	Double Cab with Standard/Long Bed				
2012-2013 Tacoma	Regular Cab with Standard Bed				
	Access Cab with Standard Bed				
	Double Cab with Standard/Long Bed				



# ALUMINUM INNERSIDES



Available in standard and extra-wide models, JOBBOX® aluminum innersides offer quick access to your tools and equipment and plenty of storage space. Self-Aligning latch hoops guarantee a tight seal the first time, and every time the lid is closed.



- RSL™ Three-Layer Rigid Structural Lid
- High-Strength Deep Beveled Edge Lid
- Full-Length Lid Bolster



- Dual Rotary GearLock II™ Locking System
- Ratcheting Action Pulls Lid Tight to Resist Prying and Pulling



Heavy-Duty Gas Springs for Self-Rising Lid



Full-Length Storage Bin

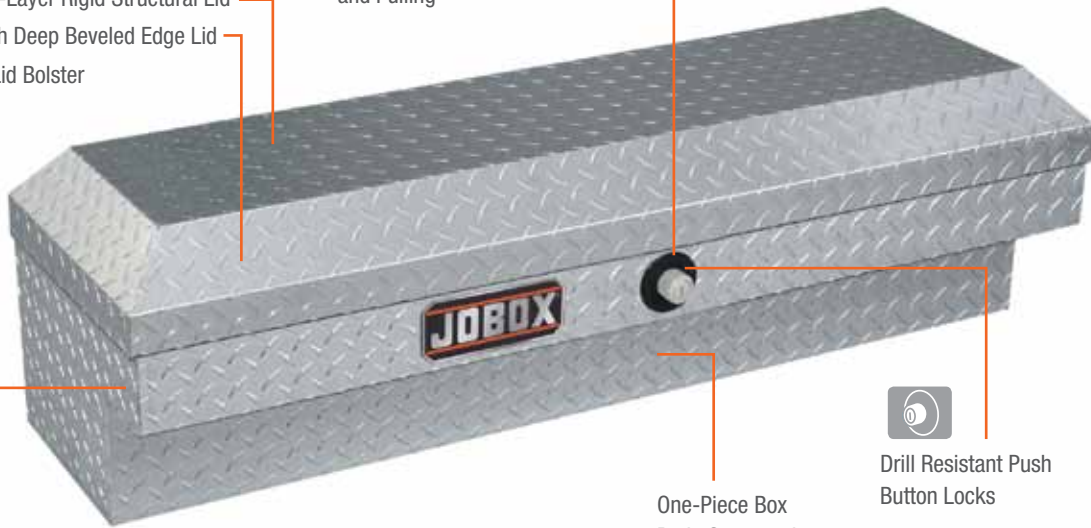

Drill Resistant Push Button Locks

One-Piece Box Body Construction



Self Aligning Latch Hoops



Bulb-Shaped Automotive Weather Stripping



Includes Support Legs and Mounting Kit

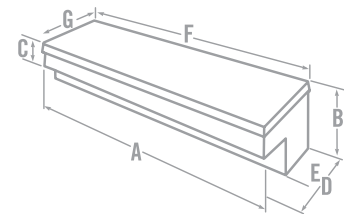

Clearcoat Cat. No.	Black Cat. No.	Size	A	B	C	D	E	F	G	Usable Cu. Ft.	App. Ship Wt.
JAN1444980	JAN1444982	47 in	46 in	13.75 in	6.88 in	14.75 in	8.5 in	46.75 in	14.38 in	2.9 ft³	36.5 lb
JAN1445980	JAN1445982	58 in	57 in	13.75 in	6.88 in	14.75 in	8.5 in	57.75 in	14.38 in	3.6 ft³	41.5 lb
JAN1447980	JAN1447982	Extra-Wide 47 in	46 in	13.75 in	6.88 in	17 in	11.13 in	46.75 in	17.25 in	3.6 ft³	39.0 lb
JAN1448980	JAN1448982	Extra-Wide 58 in	57 in	13.75 in	6.88 in	17 in	11.13 in	57.75 in	17.25 in	4.5 ft³	44.5 lb

# STEEL INNERSIDES



Designed for security and quick access in mind. JOBOX® innersides provide easy access to your tools and equipment along the bedrail of your truck. Full-length, internal storage bin allows organization of small parts and tools. Use in conjunction with crossovers for maximum storage capacity and access.

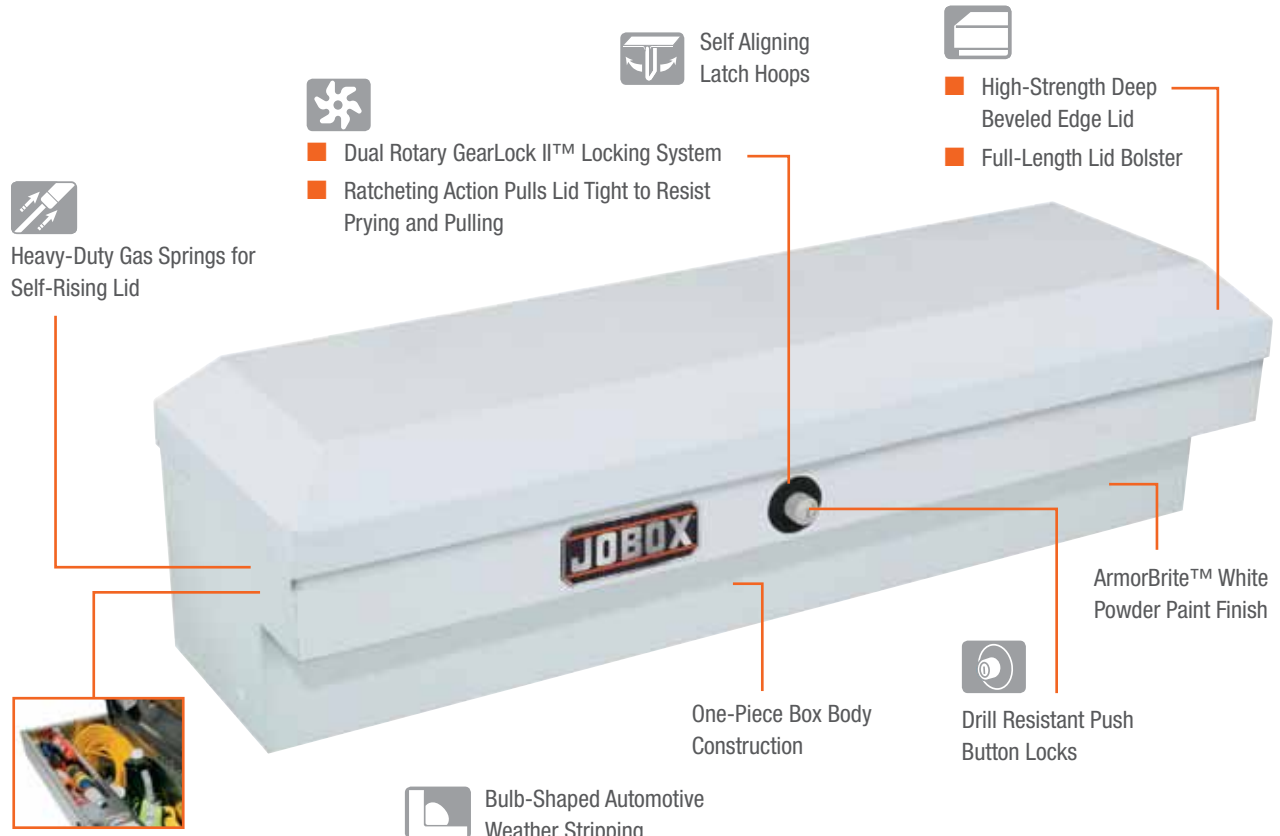

Heavy-Duty Gas Springs for Self-Rising Lid



Full-Length Storage Bin

Bulb-Shaped Automotive Weather Stripping



Includes Support Legs and Mounting Kit

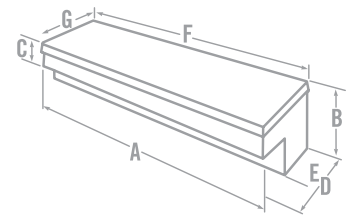

Cat. No.	Size	A	B	C	D	E	F	G	Usable Cu. Ft.	App. Ship Wt.
JSN1505980	47 in	46 in	13.63 in	6.88 in	14.63 in	8.5 in	46.5 in	14.13 in	2.9 ft³	74.5 lb
JSN1506980	58 in	57 in	13.63 in	6.88 in	14.63 in	8.5 in	57.5 in	14.13 in	4.5 ft³	86.5 lb
JSN1507980	86 in	85 in	13.63 in	6.88 in	14.63 in	8.5 in	85.5 in	14.13 in	5.4 ft³	116.0 lb
JSN1509980	Extra-Wide 47 in	46 in	13.63 in	6.88 in	17.25 in	8.5 in	46.5 in	16.75 in	3.6 ft³	80.0 lb
JSN1510980	Extra-Wide 58 in	57 in	13.63 in	6.88 in	17.25 in	8.5 in	57.5 in	16.75 in	4.9 ft³	96.5 lb

# ALUMINUM & STEEL CHESTS



Recessed Hinge



Sliding Tray for Small Parts and Tools



For unobstructed rear visibility and maximum storage space, chests are the best choice and these are the toughest, most full-featured JOBBOX makes. The Gear-Lock II™ Rotary lock system self-aligns and ratchets the lid firmly against the weather proof seal, providing resistance to prying and pull force of over 2,000 pounds.



■ RSL™ Three-Layer Rigid Structural Lid on Aluminum Models

■ High-Strength Deep Beveled Edge Lid

■ Full-Length Lid Bolster



Self Aligning Latch Hoops



Bulb-Shaped Automotive Weather Stripping

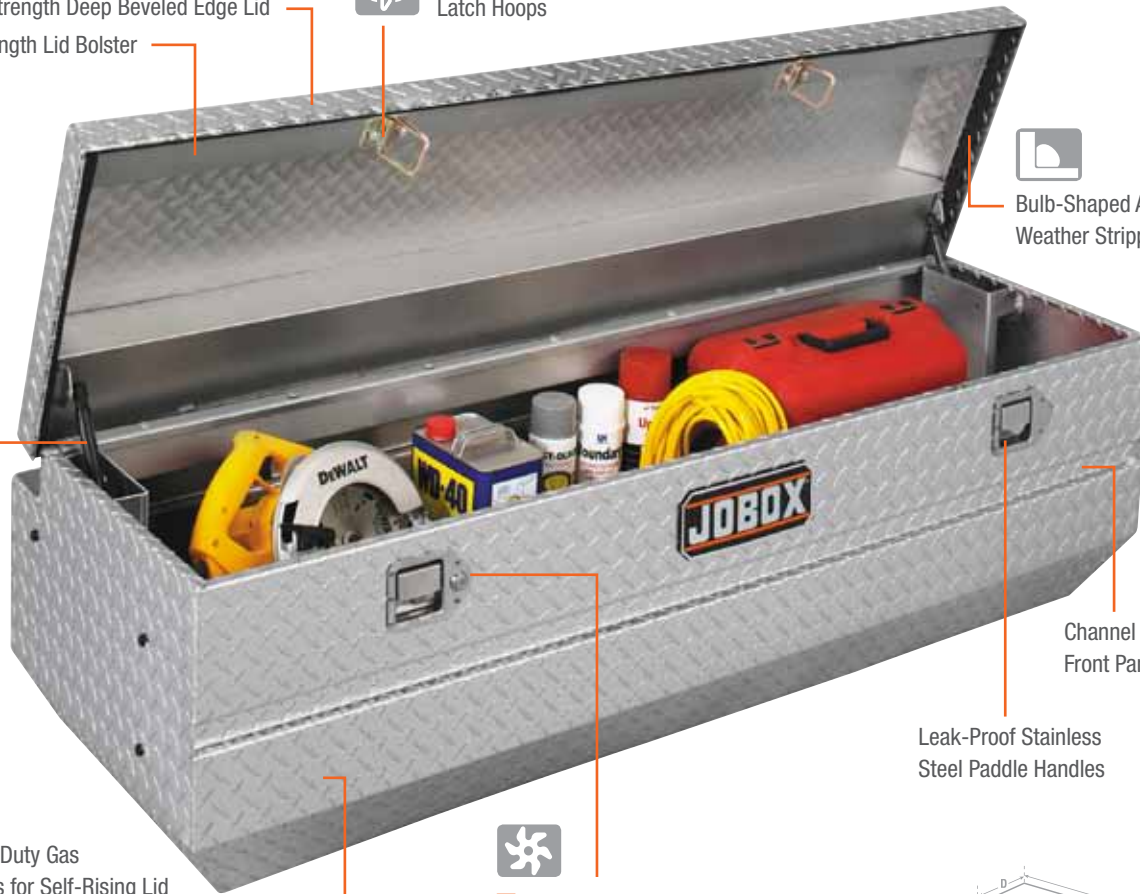

Channel Reinforced Front Panel

Leak-Proof Stainless Steel Paddle Handles



■ Heavy-Duty Gas Springs for Self-Rising Lid

■ Heavy-Duty Gas Spring Guards



■ Dual Rotary GearLock II™ Locking System

■ Ratcheting Action Pulls Lid Tight to Resist Prying and Pulling

■ Full Length Lock Console

One-Piece Box Body Construction

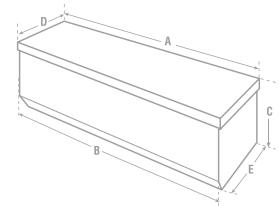

Cat. No.	Size	A	B	C	D	E	Usable Cu. Ft.	App. Ship Wt.
JAH1426980*	Fullsize Aluminum	59.38 in	58.5 in	19 in	20.63 in	20.25 in	10.2 ft³	49.0 lb
JAH1426982~	Fullsize Aluminum	59.38 in	58.5 in	19 in	20.63 in	20.25 in	10.2 ft³	49.0 lb
JSH1434980#	Fullsize Steel	59.13 in	58.5 in	19 in	20.5 in	20.25 in	10.2 ft³	121.0 lb

\* Clearcoat; ~ Black; # White



# STEEL HEAVY-DUTY CHEST



For a clear rear view and maximum storage space, chests are the best choice. This Heavy Duty Chest offers great features and value. Recessed hinges allow full opening even when placed against truck bed wall. Leak proof stainless steel handles, hoop style strikers, and a full lid bolster provide security and strength.



Recessed Hinge

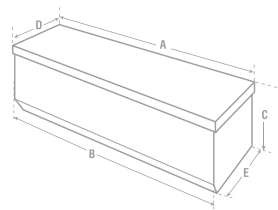

Cat. No.	Size	A	B	C	D	E	Usable Cu. Ft.	App. Ship Wt.
817980	Fullsize Steel	59.13 in	58.5 in	19 in	20.5 in	20.13 in	10.2 ft <sup>3</sup>	129.0 lb

**MOUNTING BRACKETS**



- Heavy-Duty 2" C-Channel Brackets for Mounting Underbed Boxes
- Brackets have Multiple Mounting Holes for Easy Installation
- Sold in Pairs

Cat. No.	Size
228000	18" X 18"
229000	24" X 24"

# ALUMINUM UNDERBED BOXES



Heavy Duty 0.100-Gauge Aluminum with a continuous 3/8" diameter hinge mixes strength and quality, with a clean, professional appearance. A Robust lock housing protects the lock components while loading equipment into the underbed box.

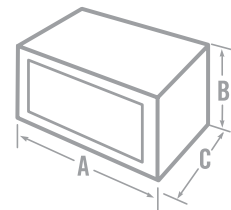
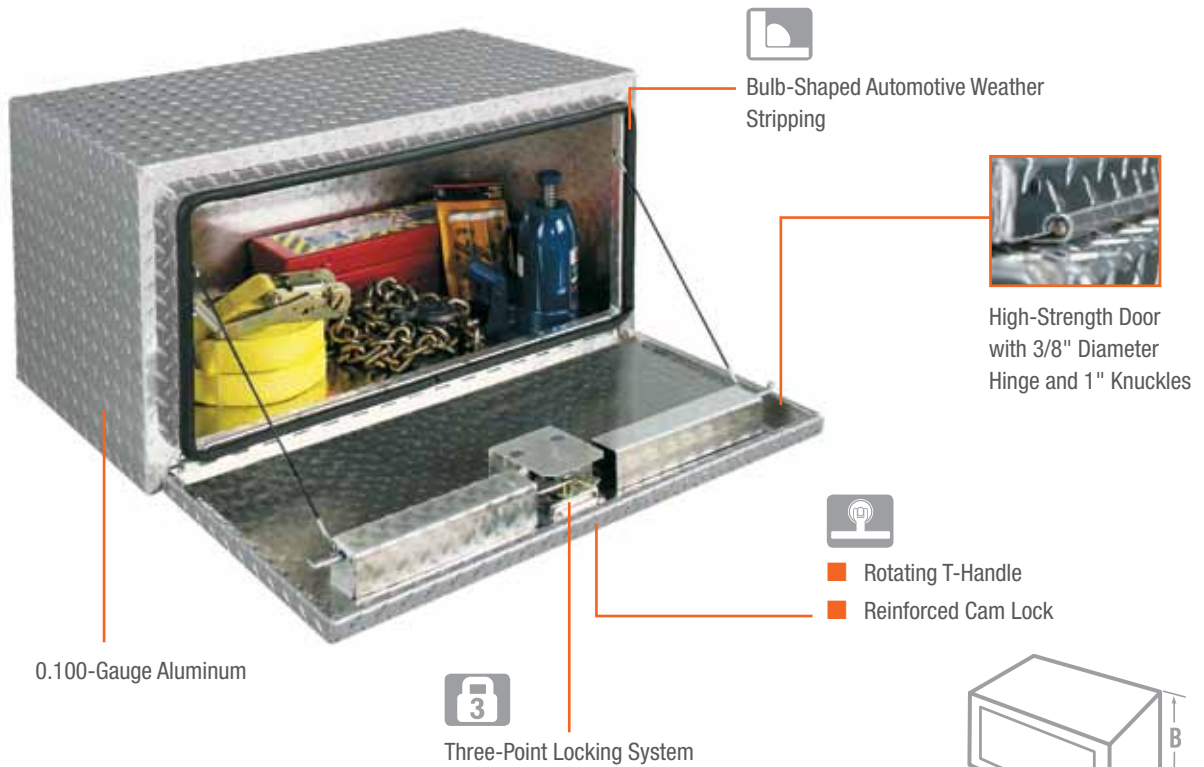

Cat. No.	Length	Width	Height	App. Ship Wt.
<b>14" Tall Aluminum Underbed Box</b>				
755980	24 in	12 in	14 in	25.0 lb
<b>18" Tall Aluminum Underbed Boxes</b>				
756980	18 in	18 in	18 in	35.0 lb
757980	24 in	18 in	18 in	40.0 lb
758980	30 in	18 in	18 in	44.0 lb
759980	36 in	18 in	18 in	48.0 lb
761980	48 in	18 in	18 in	61.0 lb
762980	60 in	18 in	18 in	74.0 lb

Cat. No.	Length	Width	Height	App. Ship Wt.
<b>24" Tall Aluminum Underbed Boxes</b>				
764980	24 in	24 in	24 in	94.0 lb
765980	30 in	24 in	24 in	110.0 lb
766980	36 in	24 in	24 in	126.0 lb
767980	48 in	24 in	24 in	158.0 lb
768980	60 in	24 in	24 in	190.0 lb

# STEEL UNDERBED BOXES



SEE THE VIDEO



Industrial-Grade Steel Hinges, Quick Release Door Connectors, and an extended rain gutter are just a few features that make JOBBOX® underbeds the most reliable and secure on the market. A rugged, one-piece lock housing helps protect the lock components and provides extra strength to the door.



Black Cat. No.	White Cat. No.	Length	Width	Height	App. Ship Wt.
<b>14" Tall Steel Underbed Boxes</b>					
727980	—	24 in	12 in	14 in	49.0 lb
728980	—	36 in	12 in	14 in	67.0 lb
729980	—	24 in	16 in	14 in	55.0 lb
731980D	—	36 in	16 in	14 in	76.0 lb
<b>18" Tall Steel Underbed Boxes</b>					
732980	741980	18 in	18 in	18 in	55.0 lb
733980	742980	24 in	18 in	18 in	68.0 lb
734980	743980	30 in	18 in	18 in	80.0 lb
735980	744980	36 in	18 in	18 in	92.0 lb
738980	745980	48 in	18 in	18 in	117.0 lb
739980	746980	60 in	18 in	18 in	142.0 lb
740980	747980	72 in	18 in	18 in	168.0 lb

Black Cat. No.	White Cat. No.	Length	Width	Height	App. Ship Wt.
<b>24" Tall Steel Underbed Boxes</b>					
748980	—	24 in	24 in	24 in	94.0 lb
749980	—	30 in	24 in	24 in	110.0 lb
750980	—	36 in	24 in	24 in	126.0 lb
752980	—	48 in	24 in	24 in	158.0 lb
754980	—	60 in	24 in	24 in	190.0 lb

## ALUMINUM TOPSIDES



Includes Mounting Kit with Support Legs and Hardware



With automotive-style bulb weather stripping and 0.100-Gauge aluminum, JOBBOX aluminum topsides are a perfect balance of strength, weather resistance, and maximizing storage space.



High Strength Door Cables

Tall, Reinforced Door Frames

0.100-Gauge Aluminum Reinforced Doors, Center Posts and Ends



Full Length Piano Hinges



Bulb-Shaped Automotive Weather Stripping



Three-Point Locking System



- Rotating T-Handles
- Reinforced Cam Lock

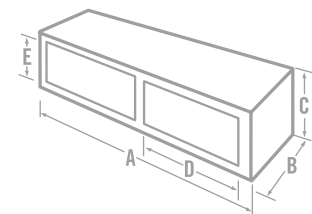

Clearcoat Cat. No.	Black Cat. No.	A	B	C	D	E	Usable Cu. Ft.	App. Ship Wt.
<b>Aluminum Standard-Capacity Topsides</b>								
857980	857982	47 in	13.19 in	16.69 in	40.06 in	12 in	5.4 ft <sup>3</sup>	44.0 lb
869980D	869982	96 in	13.19 in	16.69 in	42.06 in	12 in	11.3 ft <sup>3</sup>	78.0 lb
866980	866982	72 in	13.19 in	16.69 in	30.06 in	12 in	8.4 ft <sup>3</sup>	59.0 lb
868980	868982	87 in	13.19 in	16.69 in	37.56 in	12 in	10.1 ft <sup>3</sup>	77.0 lb
<b>Aluminum High-Capacity Topsides</b>								
543980D	543982	47 in	16 in	18.69 in	40.06 in	14 in	7.1 ft <sup>3</sup>	51.0 lb
544980	544982	65 in	16 in	18.69 in	26.56 in	14 in	9.9 ft <sup>3</sup>	69.0 lb
545980	545982	87 in	16 in	18.69 in	37.56 in	14 in	13.2 ft <sup>3</sup>	88.0 lb

# STEEL TOPSIDES



JOBBOX understands that every square inch of your truck bed space counts. Toppers provide easy access, spacious storage, and unbeatable protection while allowing you to keep the truck bed free for additional storage.



Includes Mounting Kit with Support Legs and Hardware



- Rotating T-Handles
- Reinforced Cam Lock



Bulb-Shaped Automotive Weather Stripping

Tall, Reinforced Door Frames

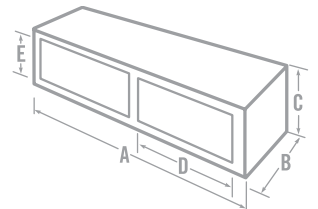
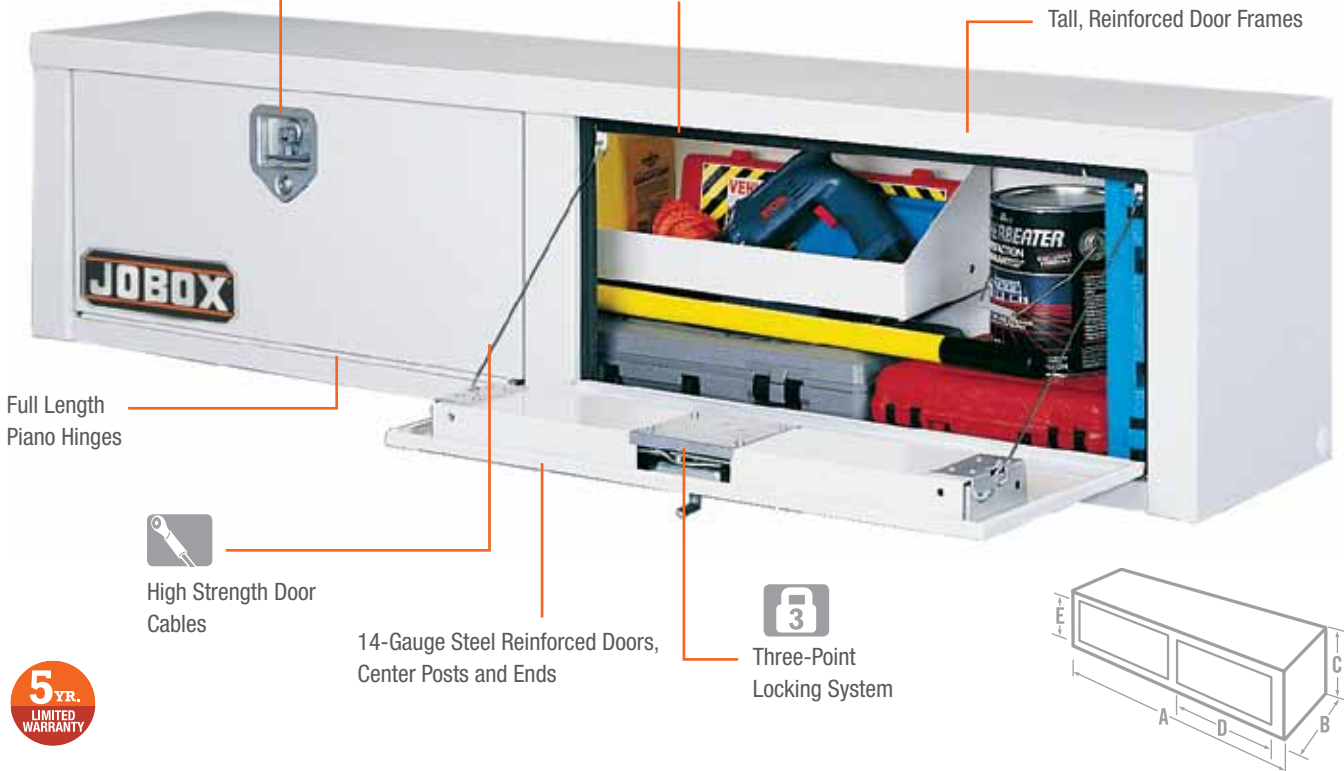

White Cat. No.	Black Cat. No.	A	B	C	D	E	Usable Cu. Ft.
<b>Steel Standard-Capacity Toppers</b>							
551980D	551982	65 in	13.19 in	16.56 in	26.81 in	12.25 in	7.1 ft <sup>3</sup>
878980	878982	87 in	13.19 in	16.56 in	37.56 in	12.25 in	10.1 ft <sup>3</sup>
879980	879982	96 in	13.19 in	16.56 in	42.38 in	12.25 in	11.3 ft <sup>3</sup>
876980	876982	72 in	13.19 in	16.56 in	30.38 in	12.25 in	8.4 ft <sup>3</sup>
550980D	550982	47 in	13.19 in	16.56 in	40.38 in	12.25 in	5.1 ft <sup>3</sup>
877980	877982	78 in	13.19 in	16.56 in	33.38 in	12.25 in	9.2 ft <sup>3</sup>
<b>Steel High-Capacity Toppers</b>							
552980	552982	47 in	15.69 in	18.56 in	40.38 in	14.25 in	6.8 ft <sup>3</sup>
553980	553982	65 in	15.69 in	18.56 in	26.81 in	14.25 in	9.5 ft <sup>3</sup>
554980	554982	87 in	15.69 in	18.56 in	37.81 in	14.25 in	12.6 ft <sup>3</sup>

# JOBBOX *StorAll* STEEL DRAWER STORAGE

14-Gauge Steel StorAll® drawer storage is designed to provide extreme durability and safety with unprecedented versatility. Perfect for work trucks, trailers, and vans, StorAll provides up to 50% more drawer weight capacity and up to 20% more storage capacity than competitive products. Drawers are customizable with adjustable front-to-rear dividers and bin dividers. Grip-And-Release™ system allows safe opening and closing of heavy drawers on sloped surfaces.

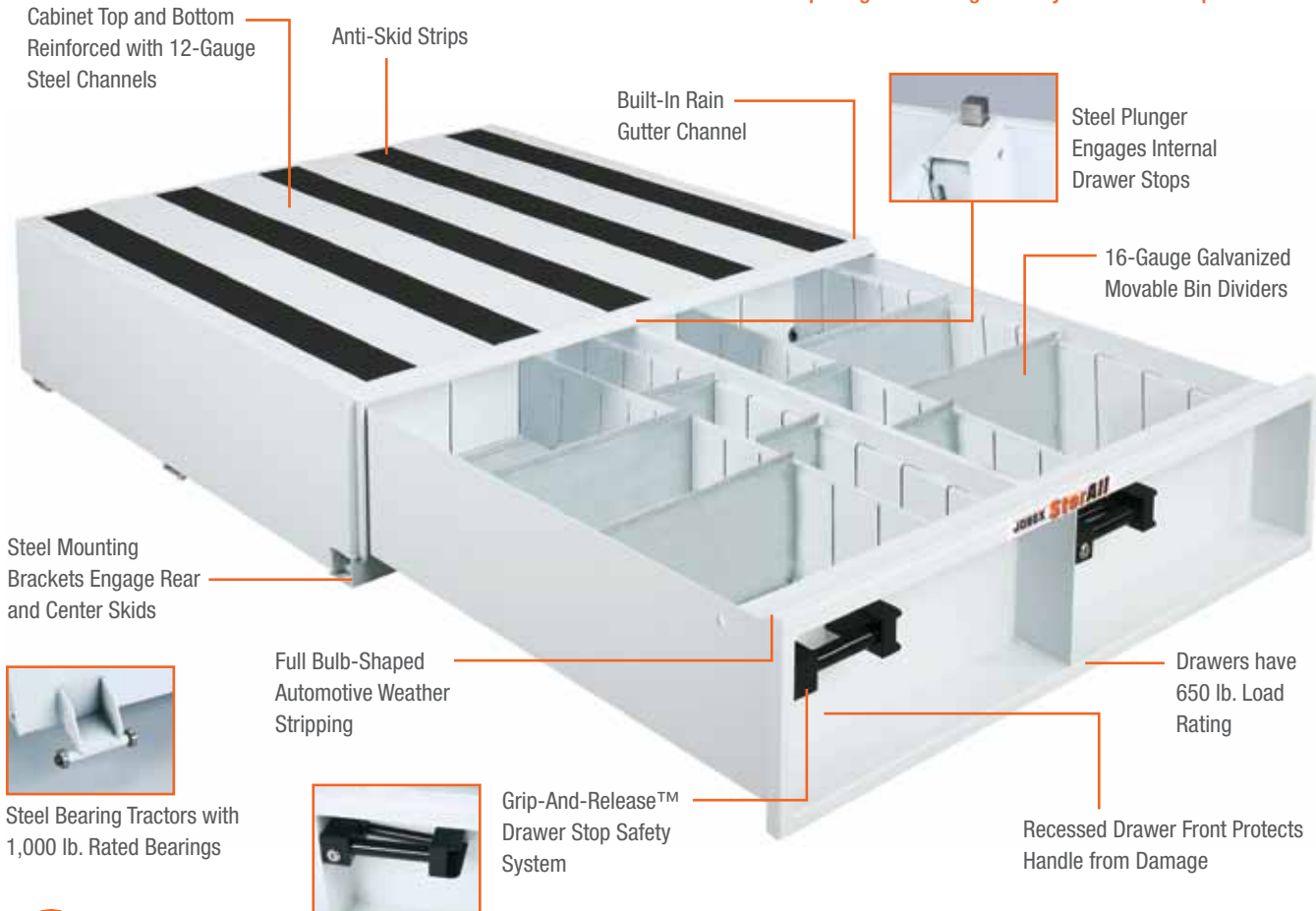

Cat. No.	Drawer Width	No. of Drawer Compartments	No. of Section Dividers	No. of Galvanized Dividers	Usable Cu. Ft.	App. Ship Wt.
<b>9" tall Drawer Units: All Models 48" Long With 5" Deep Drawer</b>						
661980	9 in	1	0	7	1 ft <sup>3</sup>	115.0 lb
664980	45 in	4	3	24	5 ft <sup>3</sup>	255.0 lb
662980	21 in	2	1	13	2.3 ft <sup>3</sup>	180.0 lb
663980	33 in	3	2	19	3.6 ft <sup>3</sup>	222.0 lb
<b>13" tall Drawer Units: All Models 48" Long With 9" Deep Drawer</b>						
665980	9 in	1	0	7	1.8 ft <sup>3</sup>	155.0 lb
666980	21 in	2	1	13	4.2 ft <sup>3</sup>	245.0 lb
667980	33 in	3	2	19	6.6 ft <sup>3</sup>	305.0 lb
668980	45 in	4	3	24	9 ft <sup>3</sup>	380.0 lb

# ALUMINUM DRAWER STORAGE

Aluminum Drawer storage is perfect for use in service vans, mini-vans, SUV's or motor home basements. Removable dividers allow for segmenting small and larger tools, supplies, or parts. Heavy-gauge aluminum is light enough for easy mobility and transport and durable enough to stand up to heavy loads on top of and in drawers.



- Extruded Heavy-Duty Drawer Glides Support up to 75 lb. per Drawer
- Pins Prevent the Drawers From Rolling Off the Glides
- Latches Automatically Lock the Drawers When Closed



0.125" Aluminum Tops Support up to 200 lb. Load per Square Foot



Moveable Dividers to Create Different Size Bins



Cat. No.	Description	Length	Width	Height	App. Ship Wt.
<b>50" Long Floor Models With One, two, three or Four Drawers</b>					
1401980	1-Drawer Floor Model	50 in	12 in	6 in	31.0 lb
1402980	2-Drawer Floor Model	50 in	24 in	6 in	61.0 lb
1403980	3-Drawer Floor Model	50 in	36 in	6 in	89.0 lb
1404980	4-Drawer Floor Model	50 in	48 in	6 in	119.0 lb
<b>50" Long One-Drawer Stacked Models two, three or Four Drawers</b>					
1407980	2-Drawer Stacked Model	50 in	12 in	12 in	59.0 lb
1408980	3-Drawer Stacked Model	50 in	12 in	18 in	85.0 lb
1409980	4-Drawer Stacked Model	50 in	12 in	24 in	114.0 lb
<b>26" Long Floor Model With three Drawers</b>					
1405980	3-Drawer Floor Model	26 in	36 in	6 in	51.0 lb
<b>26" Long Stacked Model With Six Drawers</b>					
1406980	6-Drawer Floor Model	26 in	36 in	12 in	81.0 lb
<b>Drawer Dividers</b>					
1410980	Plastic Drawer Divider	-	-	-	0.2 lb

# ALUMINUM LIQUID TRANSFER TANKS



Aluminum Transfer Tanks are designed for the toughest conditions. All tanks are made with heavy-duty 0.125" Treadplate Aluminum and pressure-tested for leaks. The Fuel-n-Tool model 433000 offers the convenience of a 72-gallon capacity transfer tank and 4.5 cubic feet of secure storage space in one unit.



- Fuel-N-Tool Chest has RSL Rigid Structural Lid
- Heavy-Duty Adjustable Lid Strikers
- Bulb-Shaped Automotive Weather Stripping



- Self-Rising Lid with Heavy-Duty Gas Spring Lid Lifts
- Leak-Proof Stainless Steel Paddle Handles



**433000 Fuel-N-Tool™ Combo**

Heavy-Duty 0.125" Treadplate Aluminum

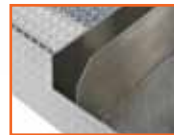

Center Baffles add Extra Strength and Control Flow of Contents

Lockable Filler Cap and Coupler

2" NPT Reinforced Bungs

Heavy-Duty Brackets for Securing the Tank to the Bed



**439000 Tank**

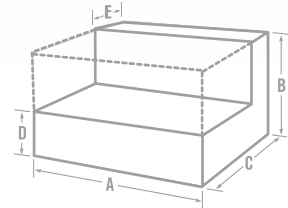

**! The Safety Capacity is the MINIMUM capacity of the tank when filled to the bottom of the Bung Fill tube, not the maximum capacity of the tank.**

Cat. No.	Shape	Safe Fill	Max Fill	A	B	C	D	App. Ship Wt.
<b>Fuel-N-Tool Combo Aluminum Transfer Tank</b>								
433000	L-Shaped Tank	72 gal (US)	77 gal (US)	48.25 in	19 in	31 in	9 in	129.0 lb
<b>Aluminum Liquid Transfer Tanks</b>								
437000	L-Shaped	99 gal (US)	104 gal (US)	57.5 in	25 in	31 in	9 in	112.0 lb
438000	Rectangular	91 gal (US)	102 gal (US)	45.25 in	23.25 in	23.25 in	-	94.0 lb
439000	Square	47 gal (US)	52 gal (US)	23.25 in	23.25 in	23.25 in	-	64.0 lb



# STEEL FUEL-N-TOOL™ TRANSFER TANKS AND CHESTS

Steel Fuel-N-Tool system offers the convenience of combining liquid transfer tanks with tool chests for secure storage space in one unit. Choose 60" chest with 6.7 cubic feet of storage space and 98 gallon tank, or 48" chest with 7.3 cubic feet of storage space and 37 gallon tank. Both Fuel-N-Tool combination options fit all full-size short wheelbase trucks.

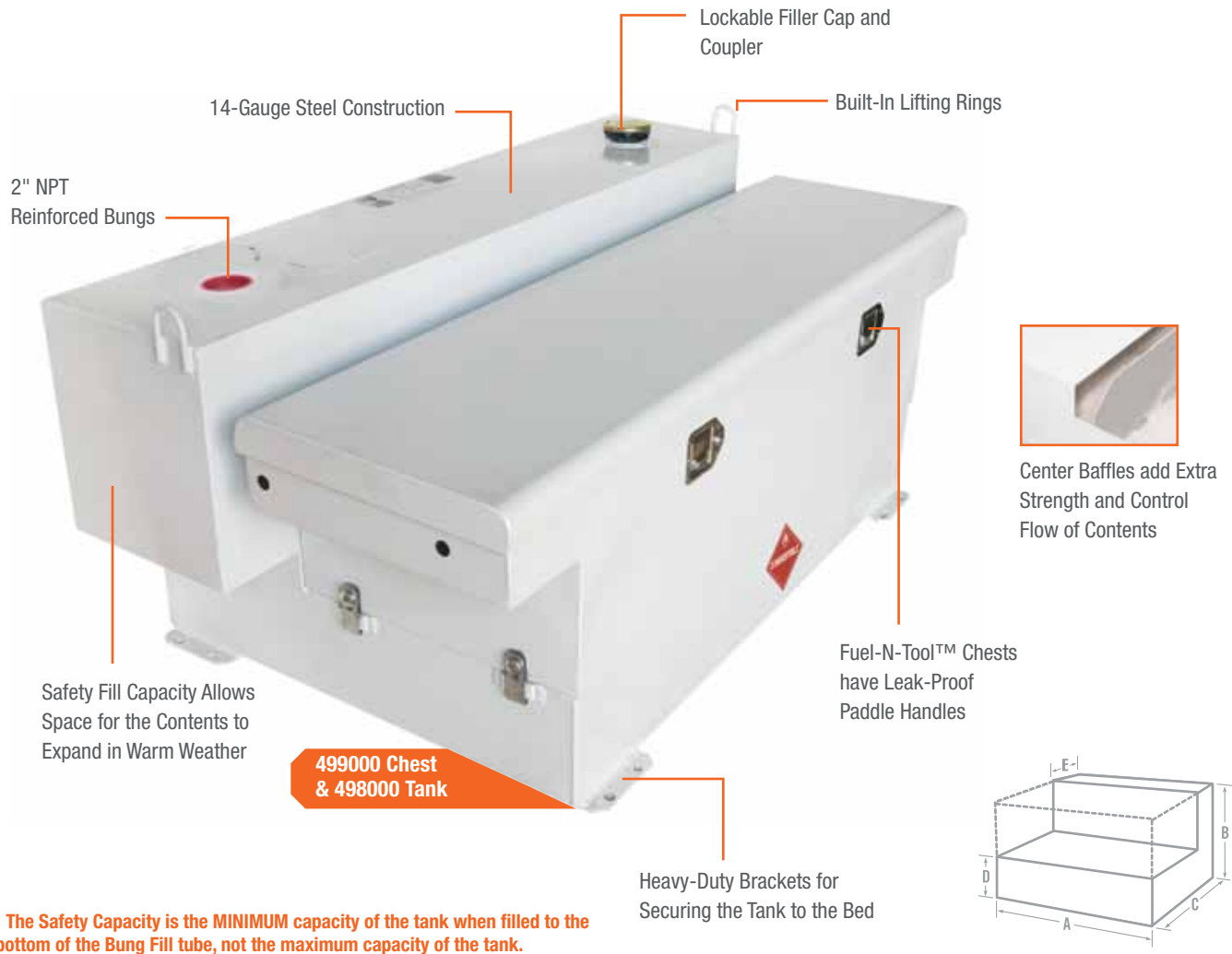

**! The Safety Capacity is the MINIMUM capacity of the tank when filled to the bottom of the Bung Fill tube, not the maximum capacity of the tank.**

Cat. No.	Used On	Safe Fill	Max Fill	A	B	C	D	E	F	G	Usable Cu. Ft.	App. Ship Wt.
<b>Steel Chests</b>												
430000	486000	-	-	48.88 in	22.25 in	10.75 in	16-1/8 in	10-3/4 in	-	-	7.3 ft³	70.0 lb
499000	498000	-	-	60.25 in	17.63 in	19.63 in	13-7/8 in	19-5/8 in	17-5/8 in	60-5/8 in	6.7 ft³	85.0 lb
<b>Steel Transfer Tanks</b>												
486000	-	37 gal (US)	42 gal (US)	59.63 in	19 in	9 in	-	-	-	-	-	97.0 lb
<b>Steel Transfer Tanks For 4-Door Trucks</b>												
498000	-	98 gal (US)	106 gal (US)	60.25 in	25 in	33 in	7.5 in	13 in	-	-	-	175.0 lb

# STEEL TRANSFER TANKS



484000

486000



Tanks feature 14-Gauge construction for long-term durability. Internal baffles reinforce the high-strength design and control the flow of the contents when moving. Model 498000 and 498002 Transfer Tanks are made for short bed trucks – including trucks with 4-door cabs. The unique design has extended sides above both wheel wells to increase the capacity. All tanks are pressure tested for leaks.



Center Baffles add Extra Strength and Control Flow of Contents

Lockable Filler Cap and Coupler

2" NPT Reinforced Bungs

Built-In Lifting Rings



480000

485000

Heavy-Duty Brackets for Securing the Tank to the Bed

14-Gauge Steel Construction

Safety Fill Capacity Allows Space for the Contents to Expand in Warm Weather

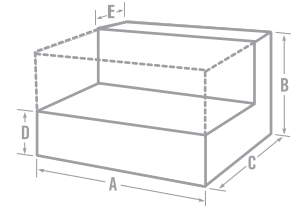

**! The Safety Capacity is the MINIMUM capacity of the tank when filled to the bottom of the Bung Fill tube, not the maximum capacity of the tank.**

Cat. No.	Description	Safe Fill	Max Fill	A	B	C	D	E	App. Ship Wt.
480000*	L-Shaped	103 gal (US)	109 gal (US)	59.63 in	25 in	31 in	9 in	11 in	200.0 lb
480002~	L-Shaped	103 gal (US)	109 gal (US)	59.63 in	25 in	31 in	9 in	11 in	200.0 lb
481000*	L-Shaped	56 gal (US)	59 gal (US)	37 in	21 in	31 in	9 in	9 in	124.5 lb
482000*	L-Shaped	51 gal (US)	54 gal (US)	29.63 in	25 in	31 in	9 in	10 in	106.0 lb
484000*	Rectangle	96 gal (US)	107 gal (US)	45.63 in	24 in	23.25 in	-	-	106.0 lb
484002~	Rectangle	96 gal (US)	107 gal (US)	45.63 in	24 in	23.25 in	-	-	144.5 lb
485000*	Square	50 gal (US)	55 gal (US)	23.25 in	24 in	23.25 in	-	-	85.5 lb
486000*	Vertical (F-N-T Ready)	37 gal (US)	42 gal (US)	59.63 in	19 in	9 in	-	-	97.0 lb
487000*	Low-Profile L-Shaped	86 gal (US)	92 gal (US)	54 in	25 in	31 in	6.5 in	11 in	186.0 lb
488000*	Low-Profile L-Shaped	76 gal (US)	82 gal (US)	48 in	25 in	31 in	6.5 in	11 in	155.0 lb
488002~	Low-Profile L-Shaped	76 gal (US)	82 gal (US)	48 in	25 in	31 in	6.5 in	11 in	155.0 lb
498000*	L-Shaped (F-N-T Ready)	98 gal (US)	106 gal (US)	60.25 in	25 in	33 in	7.5 in	13 in	175.0 lb
498002~	L-Shaped	98 gal (US)	106 gal (US)	60.25 in	25 in	33 in	7.5 in	13 in	175.0 lb

\* White; ~ Black

## KARGO MASTER PRO II™ INDUSTRIAL-GRADE LADDER RACKS



PRO II Ladder Racks are made for superior load-carrying capacity and long-term durability with swaged joints and large gussets on the cross bars. They are extra-long, providing control for heavy loads and have a 1,700 lb. capacity. They also provide better protection for the cab roof and windshield.

- Made of High Tensile-Strength 2" Diameter Steel Tubing
- Removable Fourth Cross Bar Keeps Heavier Loads from Sagging
- Rear Cross Bar is Removable for Loading Taller or Bulky Cargo
- Smooth, Round Components Reduce Wind Noise and Resistance
- Yellow Zinc Dichromate Undercoat and Marine-Grade Powder Coat Epoxy Finish
- Four Standard Mounting Plates
- A complete PRO II Ladder Rack requires ordering a Side Channel Kit and a Leg & Cross Bar Kit, see below for fitment guide

Truck Type	Truck Model	Year	Side Channel Kit Cat. No.	Leg & Cross Bar Kit Cat. No.
<b>PICKUP TRUCKS WITHOUT CAMPER OR UTILITY SHELL</b>				
Fullsize Standard Cab Trucks - Long or Short Bed Racks	All Ford F Series, Silverado, Ram, Sierra & Tundra	All	S04000	L01000
Fullsize Extended Cab - Long Bed Racks	Silverado, Ram, Sierra, Tundra, F250 & F350	All	S06000	L01000
Fullsize Crew Cab - Long Bed Racks	F250 & F350	1999 & Up	S06000	L01040
Fullsize Crew Cab - Long Bed Racks	Silverado, Sierra & Ram	All	S06000	L01000
Fullsize Extended Cab - Short Bed Racks	F150, Silverado, Sierra, Ram, Tundra, F250 & F350	All	S06010	L01000
Fullsize Crew Cab - Short Bed Racks	F250 & F350	1999 & Up	S06010	L01040
Fullsize Crew Cab - Short Bed Racks	Silverado, Sierra & Ram	All	S06010	L01000

\*Note: Short Bed Applications Simply Require Cutting To Shorten Upper Side Channels

\*\* Note: 2002 & Up Ram Requires Cutting Of S06010 Upper Side Channels. Does Not Effect Strength

## KARGO MASTER PRO III STEEL ADJUSTABLE LADDER RACKS



The 1,000 lb. capacity PRO III Ladder Racks has easily positionable legs to fit trucks with short or long beds and with standard, extended, or four-door crew cabs. No cutting required. The height of these racks can be easily raised to fit trucks with taller cabs.

- Rugged 14" Long Mounting Plates Distribute Load Over a Large Area
- Removable Rear Cross Bar for Improved Access to the Bed
- Rear Grab Handles Improve Loading and Unloading Safety
- Optional no Drill Clamp-On Mounting Plates
- Fourth Cross Bar Available for Support of Long Cargo on L80000
- Yellow Zinc Dichromate Undercoat and Marine-Grade Powder Coat Epoxy Finish

Cat. No.	Size	App. Ship Wt.
L80000	155" Long Ladder Rack Fits ALL Fullsize Trucks	150.0 lb
L80020	142" Long Ladder Rack Fits ALL Mid-Size and Compact Trucks	140.0 lb

**KARGO MASTER** PRO IV ALUMINUM ADJUSTABLE LADDER RACKS



Swaged joints and fully gusseted crossbars for superior load capacity make the PRO IV Aluminum Ladder Rack a perfect choice. The rack has triple-plated fasteners with chrome plating over double nickel plating.

- Rugged 14" Long Mounting Plates Distribute Load Over a Large Area
- Removable Rear Cross Bar for Improved Access to the Bed
- Rear Grab Handles Improve Loading and Unloading Safety
- Optional no drill Clamp-On Mounting Plates
- Fourth Cross Bar Available for Support of Long Cargo on L80000
- Yellow Zinc Dichromate Undercoat and Marine-Grade Powder Coat Epoxy Finish

Cat. No.	Size	App. Ship Wt.
L90000	Aluminum Fully-Adjustable Ladder Rack Fits ALL Fullsize Trucks	95.0 lb

**KARGO MASTER** QUICK PAC REMOVABLE LADDER RACKS



Quick Pac Racks are easy to insert in the mounting bases when needed and easily lifted out of the bases until needed again. The side-mounted racks support 250 lb. and are ideal for occasional use or when a full-length or heavier-duty rack is not required.

- Easy-to-Install Removable Racks for Carrying a Ladder, Lumber or Other Long Material
- Support Arms Adjust From 18" to 32" in Width
- Yellow Zinc Dichromate Undercoat and Marine-Grade Powder Coat Epoxy Finish
- High-Strength Mounting Bases fit in any truck and can be used on either side
- 1-1/4" Square Steel Uprights have fully welded joints

Cat. No.	Size	App. Ship Wt.
L30090	Removable Side Ladder Racks	60.0 lb

**KARGO MASTER** FREE-STANDING ECONO RACKS



Econo Racks can be used as a pair for extra support or free-standing to provide a wide area for easy side access to bulky cargo. Long mounting plates provide stability without horizontal connecting bars. Can be paired with Window Guard A31090 to create Free-Standing Fullsize Cab Guard.

- High-Strength 2" Diameter Steel Racks Support up to 500 lb.
- Cross Bar Height can be set at 23-1/2" or 26-1/4" above the bed
- Rack width adjusts from 53" to 68"
- 14" Long Heavy-Duty Bolt-On Mounting Plates
- Yellow Zinc Dichromate Undercoat and marine-Grade Powder Coat Epoxy Finish

Cat. No.	Description	Width	Height	App. Ship Wt.
L30050	Front-Mounted Econo Rack	53 in - 68 in	23-1/2 in - 26-1/4 in	35.0 lb

**KARGO MASTER LADDER RACK ACCESSORIES**

**FULLSIZE TRUCK WINDOW GUARD**

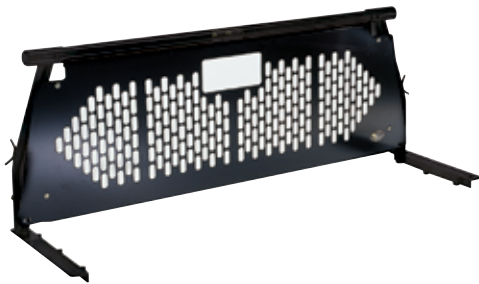

- Bolts On Existing Rack (rack and mounting plates not Included)

Cat. No.	App. Ship Wt.
A31080D	22 lb

**“NO DRILL” CLAMP-ON MOUNTING KIT**



- For PRO II, PRO III, and Econo Rack Model L30040

Cat. No.	App. Ship Wt.
A31580	4.0 lb

**EXTRA CROSS BAR**



- Bolts on Side Channels
- For PRO III Model L80000

Cat. No.	App. Ship Wt.
A31600	12.0 lb

### HOW TO MEASURE YOUR TRUCK

The following instructions generally work well when measuring a full-size truck. Mid-size and Compact trucks have a variety of truck bed configurations which increase the difficulty in measuring the truck and comparing it to the dimensions of a specific truck box. In nearly all instances, the Fitment Guide (pages 54 through 59) will provide accurate information unless the truck is a new model introduced after August, 2013.

#### THE TRUCK BED NEEDS TO BE MEASURED FOR TWO REASONS:

- A. To Determine that the Truck Box will be long enough to be properly mounted on the truck bed rails.
- B. To Determine whether or not the truck wheel wells will interfere and prevent proper mounting of the truck box.

#### A: Determining that the truck box is long enough to be properly mounted:

**Measurement 1:** Width between the top of the bed sidewalls. Dimension "A" of the crossover Truckbox needs to be at least 3" greater.

#### B. Determining whether or not the truck box will clear the wheel wells in the truck....Need to find POINT "X" in the truck bed:

Preparing to take Measurements 2 & 3 to find a point "X" in the truck bed to ensure that the truck box will fit your truck:

- The depth of the truck box may restrict its fit in the truck because the wheel well might be in the way.
- Except for "Extra-Wide" truck boxes, most truck boxes will require 20-1/4" of horizontal space from the cab bed rail to the point where the Truck Box might hit the wheel well or the truck bed liner.



**Measurement 2:** A "Standard" Truck box will usually have a 9" Vertical depth below the top of the truck bed rail. A "Deep" model will usually be 12" below the top of the bed rail.

- Determine how deep a truck box you need and measure down from the top of the rail and create an imaginary, HORIZONTAL line at the depth of the truck box you need...usually 9" or 12" below the top of the truck bed rail. This is called Dimension "C" on the truck box.

**Measurement 3:** Find Point "X" which is on the horizontal "Imaginary Line" below the truck rail (from "2" above). On the horizontal "Imaginary Line"....Measure to find a point 20-1/4" away from the front truck bed rail (This measurement is from the Cab Truck Bed Rail Towards the Tailgate). The 20 1/4" is roughly Dimension "E" on the truck box and represents how much space the truck box will take in the bed behind the truck cab. After finding Point "X" in your Truck Bed....will the truck box fit?: Again, Point "X" is 20-1/4" away from the front truck cab rail on the Imaginary Horizontal Line (from measurement 2) If point "X" does not hit the wheel well, the truck box will fit. If point "X" hits the Wheel Well, you must make another measurement:

- Mark Point "X" on both wheel wells or the wheel well bed liner
- Measure the distance between the two point "X"s on the truck bed. This dimension must be greater than Dimension "B" on the Truckbox
- If Dimension "B" on the truck box is GREATER than the distance between both point "X"s, the truck box will hit the wheel well or bed liner and you will usually need to select another truck box or mount the truck box with a spacer above the bed rail.

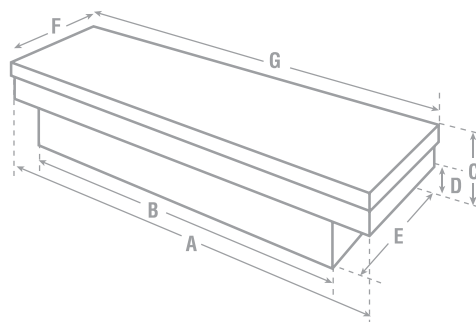

## PRODUCT WARRANTY INFORMATION

### JOBBOX Products Limited Warranties

This product warranty is made by Apex Tool Group, LLC (ATG) to only the original purchaser and it is valid as indicated in the table below from date of purchase, upon presentation of the original sales receipt at the time the warranty claim is made. ATG warrants its product to be free from defects in materials and workmanship at the time of the sale. This warranty does not cover damage caused by accident or unreasonable or unintended use of the product. Modification, disassembly and/or reassembly of the product will invalidate this warranty. Damage to the contents of the box, vehicle or other consequential damages of whatever kind are hereby excluded from this warranty. Use only parts or accessories supplied by Apex Tool Group, LLC. Parts or accessories from other manufacturers or suppliers could alter the function and safety of the product(s) and void this warranty.

<b>Crossovers, Innerside, Chests, Topsides and Underbed Truck Boxes</b> .....	<b>5 Years</b>
<b>On-Site Storage Products</b> .....	<b>1 Year</b>
<b>Liquid Transfer Tanks</b> .....	<b>1 Year</b>
<b>Safety Cabinets</b> .....	<b>5 Years</b>
<b>Safety Cans</b> .....	<b>5 Years</b>

JOBBOX cannot offer specific recommendations on chemical compatibility. Your chemical supplier, MSDS sheets, or other expert sources should be consulted. JOBBOX makes no guarantee of results and assumes no obligation or liability in connection with the use of these products and their application relative to their chemical compatibility. It is the end user's sole responsibility to determine the nature of the materials to be contained and to select the proper product suitable for a particular application. Furthermore, it is the end user's responsibility to insure that the product selected is suitable for its intended use. JOBBOX makes no warranty, expressed or implied of merchantability or fitness for purpose, and assumes no liability in connection with any product made or sold by JOBBOX with regard to its use of chemical compatibility.

### KargoMaster Ladder Rack Lifetime Frame Warranty

KargoMaster, Inc. extends to the original purchaser of a KargoMaster product a Lifetime Frame Warranty. If the rack cracks, bends, buckles, or structurally fails in any way, KargoMaster, at its option and expense, will replace or repair the rack. For details, see the Installation Instruction Booklet included with the rack or contact Customer Service.

### To Obtain Warranty Service:

In the case of a nonconforming product, you should return the product to the place where it was purchased. The seller will consult with ATG and then either repair or replace the product, at ATG's sole option, if it is determined that the product is defective in either material or workmanship.

Please have the following information available to request keys, gas springs or replacement parts:

- The Key Code stamped on your key or the outside cover of the lock cylinder
- The Model Number on the label on the barrel of the gas spring
- For other replacement parts, the Model Number of your product

To obtain parts, call our Customer Service Department at the number below between 8:00 AM and 5:00 PM Eastern Standard Time Monday through Friday. Press 1 when prompted. To send an email, use the address below.

1-800-643-0084  
8:00 am - 5:00 pm EST  
customer.service@apextoolgroup.com

# **JOBBOX**

**PREMIUM STORAGE SOLUTIONS**

The products in this Catalog may be covered by one or more of the following US Patents: 5,586,702 – 5,601,206 – 5,875,948 – 6,209,739 – 6,254,208 – 6,464,095 – 6,681,604 – 6,803,167 – 6,959,846 - 7,370,890, D369,342 & D355,766 Or, by Patent Applications that are pending.

The Trademarks included in this catalog are registered by or have been applied for by Apex Tool Group, LLC except KargoMaster Ladder Racks which is the property of that company.

**Distributed by:**

**[www.deltastorage.com](http://www.deltastorage.com)**  
**[www.safety.jobox.com](http://www.safety.jobox.com)**

**[www.deltajobox.com](http://www.deltajobox.com)**

©2014 Apex Tool Group, LLC  
14600 York Road, Suite A  
Sparks, MD 21152  
[www.apextoolgroup.com](http://www.apextoolgroup.com)

Customer Service:  
Phone: 800.643.0084  
Fax: 877.356.4081  
[customer.service@apextoolgroup.com](mailto:customer.service@apextoolgroup.com)

Printed in U.S.A.  
#T550882  
6/24/2014  
[www.deltastorage.com](http://www.deltastorage.com)