



Operating Instructions and Parts Manual Horizontal-Vertical Band Saw

Model HVBS-56



JET
427 New Sanford Road
LaVergne, Tennessee 37086
Ph.: 800-274-6848
www.jettools.com

Part No. M-414458
Revision H3 09/2018
Copyright © 2017 JET



1.0 IMPORTANT SAFETY INSTRUCTIONS

Read and understand the entire instruction manual before operating machine.

This band saw is designed and intended for use by properly trained and experienced personnel only. If you are not familiar with the proper and safe operation of a band saw, do not use until proper training and knowledge have been obtained.

WARNING – To reduce risk of injury:

- a. Wear eye protection.
 - b. Do not remove jammed cut off pieces until blade has stopped.
 - c. Maintain proper adjustment of blade tension, blade guides, and thrust bearing.
 - d. Adjust upper guide to just clear workpiece.
 - e. Secure workpiece firmly against table.
1. Read and understand the warnings posted on the machine and in this manual. Failure to comply with all of these warnings may cause serious injury.
 2. Replace the warning labels if they become obscured or removed.
 3. Do not use this band saw for other than its intended use. If used for other purposes, JET disclaims any real or implied warranty and holds itself harmless from any injury that may result from that use.
 4. Always wear ANSI Z87.1 approved safety glasses or face shield while using this band saw. (Everyday eyeglasses only have impact resistant lenses; they are *not* safety glasses.)
 5. Before operating this machine, remove tie, rings, watches and other jewelry, and roll sleeves up past the elbows. Do not wear loose clothing. Confine long hair. Non-slip footwear or anti-skid floor strips are recommended. Do not wear gloves.
 6. Wear hearing protection (plugs or muffs) during extended periods of operation.
 7. Do not operate this machine while tired or under the influence of drugs, alcohol or any medication.
 8. Reduce the risk of unintentional starting. Make sure switch is in off position before plugging in.
 9. Make certain the machine is properly grounded.
 10. Make all machine adjustments or maintenance with the machine unplugged from the power source.
 11. Remove adjusting keys and wrenches. Form a habit of checking to see that keys and adjusting wrenches are removed from the machine before turning it on.
 12. Keep safety guards in place at all times when the machine is in use. If removed for maintenance purposes, use extreme caution and replace the guards immediately after completion of maintenance.
 13. Check damaged parts. Before further use of the machine, a guard or other part that is damaged should be carefully checked to determine that it will operate properly and perform its intended function. Check for alignment of moving parts, binding of moving parts, breakage of parts, mounting and any other conditions that may affect its operation. A guard or other part that is damaged should be properly repaired or replaced.
 14. Provide for adequate space surrounding work area and non-glare, overhead lighting.
 15. Keep the floor around the machine clean and free of scrap material, oil and grease.
 16. Keep visitors a safe distance from the work area. Keep children away.
 17. Make your workshop child proof with padlocks, master switches or by removing starter keys.
 18. Give your work undivided attention. Looking around, carrying on a conversation and “horse-play” are careless acts that can result in serious injury.
 19. Maintain a balanced stance at all times so that you do not fall into the blade or other moving parts. Do not overreach or use excessive force to perform any machine operation.
 20. Use the right tool at the correct speed and feed rate. Do not force a tool or attachment to do a job for which it was not designed. The right tool will do the job better and more safely.
 21. Use recommended accessories; improper accessories may be hazardous.
 22. Maintain tools with care. Keep saw blades sharp and clean for the best and safest performance. Follow instructions for lubricating and changing accessories.
 23. Turn off the machine before cleaning. Use a brush or compressed air to remove chips or debris — do not use your hands.
 24. Do not stand on the machine. Serious injury could occur if the machine tips over, or if the cutting tool is unintentionally contacted.

25. Never leave the machine running unattended. Turn the power off and do not leave the machine until it comes to a complete stop.
26. Remove loose items and unnecessary work pieces from the area before starting the machine.
27. Make sure workpiece is securely clamped in vise. Never use your hand to hold the workpiece.
28. Never reach around or over a moving saw blade.
29. Feed work into a blade or cutter only against the direction of rotation of the blade or cutter.
30. Set blade guides for minimal exposure of blade before operating.
31. Don't use in dangerous environment. Don't use power tools in damp or wet location, or expose them to rain. Keep work area well lighted.
32. Use proper extension cord. Make sure your extension cord is in good condition. When using an extension cord, be sure to use one heavy enough to carry the current your product will draw. An undersized cord will cause a drop in line voltage resulting in loss of power and overheating. Table 1 (sect. 6.3) shows correct size to use depending on cord length and nameplate ampere rating. If in doubt, use the next heavier gage. The smaller the gage number, the heavier the cord.

⚠ WARNING: This product can expose you to chemicals including lead which is known to the State of California to cause cancer and birth defects or other reproductive harm, and ethylbenzene which is known to the State of California to cause cancer. For more information go to <http://www.p65warnings.ca.gov>.

⚠ WARNING: Some dust, fumes and gases created by power sanding, sawing, grinding, drilling, welding and other construction activities contain chemicals known to the State of California to cause cancer and birth defects or other reproductive harm. Some examples of these chemicals are:

- lead from lead based paint
- crystalline silica from bricks, cement and other masonry products
- arsenic and chromium from chemically treated lumber

Your risk of exposure varies, depending on how often you do this type of work. To reduce your exposure to these chemicals, work in a well-ventilated area and work with approved safety equipment, such as dust masks that are specifically designed to filter out microscopic particles. For more information go to <http://www.p65warnings.ca.gov/> and <http://www.p65warnings.ca.gov/wood>.

Familiarize yourself with the following safety notices used in this manual:

⚠ CAUTION This means that if precautions are not heeded, it may result in minor injury and/or possible machine damage.

⚠ WARNING This means that if precautions are not heeded, it may result in serious, or possibly even fatal, injury.

SAVE THESE INSTRUCTIONS

2.0 About this manual

This manual is provided by JET, covering the safe operation and maintenance procedures for a JET Model HVBS-56 Band Saw. This manual contains instructions on installation, safety precautions, general operating procedures, maintenance instructions and parts breakdown. Your machine has been designed and constructed to provide consistent, long-term operation if used in accordance with the instructions as set forth in this document.

If there are questions or comments, please contact your local supplier or JET. JET can also be reached at our web site: www.jettools.com.

Retain this manual for future reference. If the machine transfers ownership, the manual should accompany it.

⚠ WARNING Read and understand the entire contents of this manual before attempting assembly or operation! Failure to comply may cause serious injury!

3.0 Table of contents

Section	Page
1.0 IMPORTANT SAFETY INSTRUCTIONS	2
2.0 About this manual	3
3.0 Table of contents.....	4
4.0 Specifications.....	5
5.0 Setup and assembly.....	6
5.1 Shipping contents.....	6
5.2 Tools required for assembly	6
5.3 Unpacking and cleanup.....	6
5.4 Assembling stand.....	7
5.5 Mounting saw to stand	7
5.6 Additional assembly	7
5.7 Vertical cutting plate	8
6.0 Electrical connections	8
6.1 GROUNDING INSTRUCTIONS	8
6.2 Voltage conversion.....	9
6.3 Extension cords.....	9
7.0 Adjustments	10
7.1 Tools required for adjustments.....	10
7.2 Blade speed adjustment.....	10
7.3 Blade guide adjustment.....	10
7.4 Blade tension.....	11
7.5 Blade changes.....	11
7.6 Blade guide bearings.....	11
7.7 Blade tracking.....	12
7.8 Feed pressure adjustment.....	12
7.9 Blade-to-table squareness	12
7.10 Auto shut-off adjustment	13
7.11 Vise adjustment.....	13
7.12 Vertical stop adjustment	13
8.0 Operation	13
8.1 Blade break-in	13
8.2 General operating procedure	13
8.3 Evaluating cutting efficiency.....	14
9.0 User-maintenance.....	14
9.1 Lubrication.....	14
9.2 Additional servicing	15
10.0 Troubleshooting HVBS-56 Band Saw	15
10.1 Mechanical and electrical problems	15
10.2 Operational problems	16
11.0 Replacement Parts.....	16
11.1.1 HVBS-56 Bow Assembly – Exploded View	17
11.1.2 HVBS-56 Bed Assembly – Exploded View.....	18
11.1.3 HVBS-56 – Bow and Bed Assemblies Parts List.....	19
11.2.1 HVBS-56 Stand – Exploded View	22
11.2.2 HVBS-56 Stand – Parts List.....	22
12.0 Electrical Connections – HVBS-56 Band Saw	23
13.0 Warranty and service	24

4.0 Specifications

Model number HVBS-56
Stock number 414458

Motor and electricals:

Motor type (UL listed) totally enclosed fan cooled, induction, capacitor start
Horsepower 1/2 HP (0.37 kW)
Phase single
Voltage 115/230V (prewired 115V)
Cycle 60Hz
Listed FLA (full load amps) 9/4.5 A
Starting amps 10.1 A
Running amps (no load) 4.9 A
Start capacitor 200MFD 125 VAC
Power transfer v-belt
On/off switch toggle
Motor speed 1720 RPM
Power cord SJT 3x18AWG, 300V, length 6 ft. (183 cm)
Power plug installed 120V
Recommended circuit and fuse/breaker size ¹ 15A

Capacities:

Horizontal capacity:
Round at 90 degrees 5 in.
Round at 45 degrees 3 in.
Rectangle at 90 degrees 5(H) x 5-3/4(W); and 2(H) x 6(W) in.
Rectangle at 45 degrees 4-1/2(H) x 3(W) in.
Throat depth 5 in. (127 mm)

Bow and blade:

Blade type (provided) Raker
Blade size 1/2 x 0.025 x 64-1/2 in.
Number of blade speeds 3
Blade speeds 80, 120, 200 SFPM
Blade wheel diameter 7-3/8 in. (187 mm)

Bed and vise:

Bed height from floor 25-1/2 in. (648 mm)
Vise swivel 45 deg.

Main materials:

Bed cast iron, ground surface
Bow cast iron
Stand steel
Blade drive system steel, heat-treated worm driving a bronze worm gear in oil bath
Side blade guides ball bearings mounted on eccentric shafts
Rear blade guides ball bearings
Band wheels flanged cast iron

Dimensions:

Vertical table plate dimensions 9-5/8 x 9-1/2 in. (244.5 x 241 mm)
Floor space required 16-1/4 x 42-1/2 in. (413 x 1080 mm)
Overall dimensions, assembled machine L37 x W17.72 x H41.34 in. (940 x 450 x 1050 mm)
Overall dimensions, shipping carton L38.78 x W13.98 x H17.80 in. (985 x 355 x 452 mm)

Weights:

Net weight (approx.) 115 lbs. (52 kg)
Shipping weight (approx.) 143.30 lbs. (65 kg)

¹ Subject to local/national electrical codes.

The specifications in this manual were current at time of publication, but because of our policy of continuous improvement, JET reserves the right to change specifications at any time and without prior notice, without incurring obligations.

5.0 Setup and assembly

⚠WARNING Read and understand all instructions before attempting assembly. Band Saw must be disconnected from power during all assembly procedures. Failure to comply may cause serious injury.

5.1 Shipping contents

See Figures 1 and 2.

- 1 Band saw (not shown)
- 1 Pulley cover – A
- 2 Wheels – B
- 2 Adjustable foot with nuts and washer – C
- 1 Vertical cutting plate – D
- 1 Vertical cutting plate stand – E
- 1 Open end wrench 12/14mm – F
- 1 Work stop assembly – G
- 1 Handle – H
- 1 Belt – I
- 1 Handwheel – J
- 1 Axle – K
- 1 Stand shelf – L
- 2 Stand cross braces – M
- 1 Stand front panel – N
- 4 Stand legs (2 LH, 2 RH) – O
- 1 Hardware package, includes:
 - 20 Phillips hd screws, 1/4x5/8 – HP1
 - 6 Socket hd cap screws, 5/16x1-1/4 – HP2
 - 2 Cotter pins, 1/8x1 – HP3
 - 6 Flat washers, 5/8 – HP4
 - 20 Flat washers, 1/4 – HP5
 - 21 Hex nuts, 1/4 – HP6
 - 1 Flat head screw, 1/4 x 3/4 – HP7
 - 6 Flat washers, 5/16 – HP8
 - 2 Hex cap screw, 3/16x1/2 – HP9
 - 6 Hex nuts, 5/16 – HP10

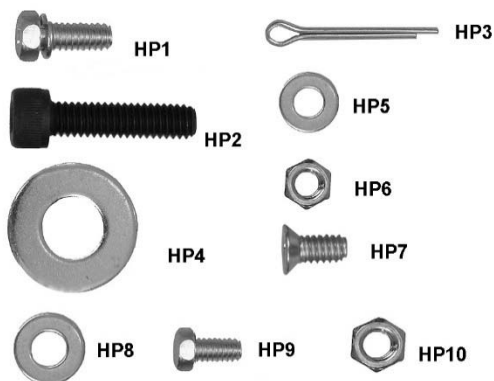

Figure 1: Hardware package p/n HVBS56MG-HP

5.2 Tools required for assembly

Wrenches, 10mm, 12mm
 Hex key, 4mm
 #2 cross point screwdriver
 Pliers

(Note: Ratchets and sockets will speed assembly.)

5.3 Unpacking and cleanup

1. Inspect all contents for shipping damage. Compare contents of shipping carton with contents list in this manual. Report any damage or part shortages to your distributor.
2. Do not discard packing material until saw is assembled and running properly.
3. Remove rust protectant from exposed surfaces, such as bed, vise assembly, etc., with a clean rag and cleaner/degreaser. Apply a light coat of oil on these surfaces to inhibit rust.

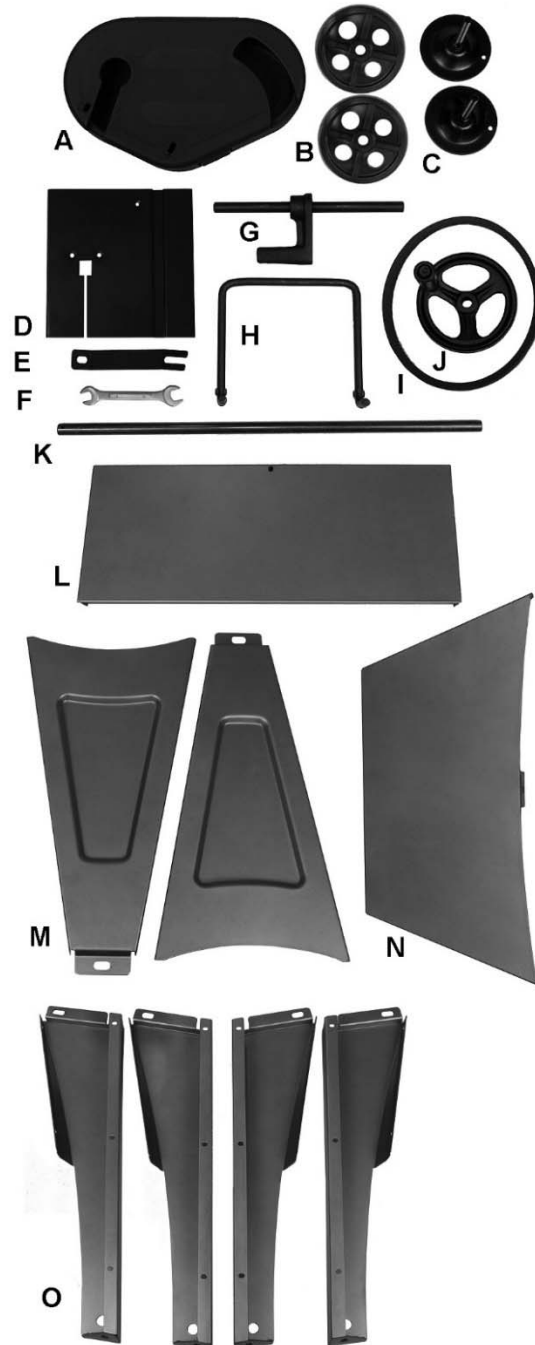

Figure 2

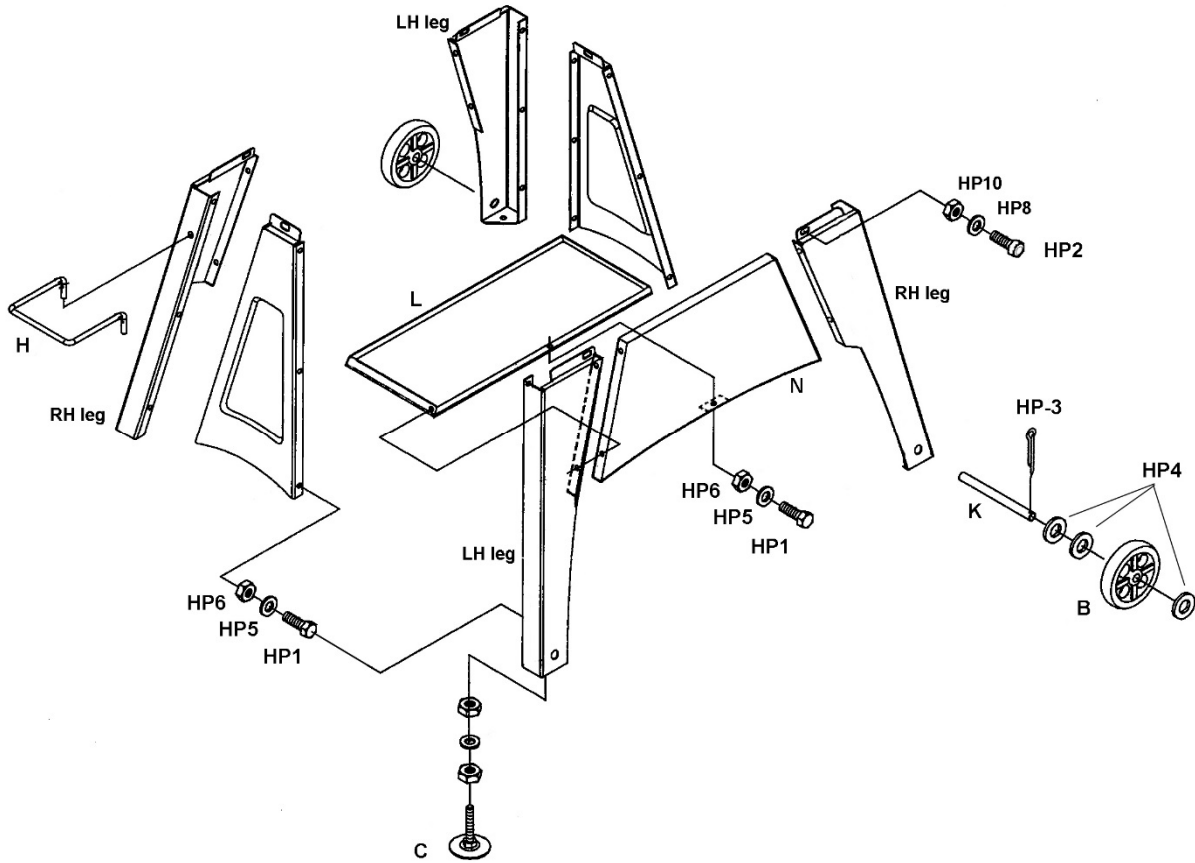

Figure 3

5.4 Assembling stand

Refer to Figure 3.

NOTE: Only make fasteners hand-tight at this time. They will be fully tightened after band saw has been settled atop stand.

1. Assemble legs, cross braces, front panel and shelf, as shown in Figure 3.
2. Install handle (H) into end of assembled stand.
3. Install axle and wheels on right side of stand. Use two flat washers between wheel and stand leg on each side. Insert cotter pin (HP3) at each axle end and bend prongs to secure.
4. Install adjustable feet (C) at opposite end of stand and adjust until stand is level.

5.5 Mounting saw to stand

CAUTION Saw is heavy; two-person lift.

1. With help from another person, position saw atop stand, and secure with socket head cap screws and washers (HP2/5/6, Figure 3).
2. **Fully tighten** all fasteners on stand assembly.

5.6 Additional assembly

1. Remove shipping bracket (P, Figure 4) and adjust switch trip (Q) so that it will turn off switch when bow reaches down position. (Note: Switch trip is bendable for optimum positioning.)

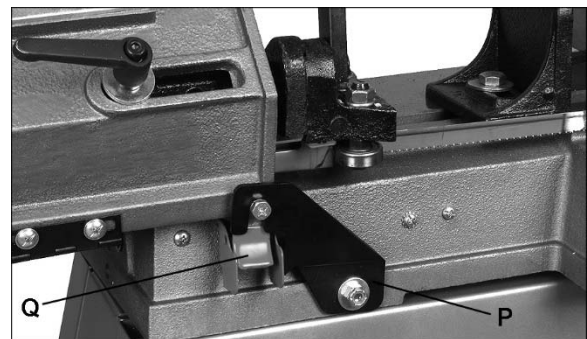

Figure 4

2. Install handwheel (J, Figure 5) onto vise lead screw, and tighten set screw.
3. Install workstop rod (G) into hole and tighten set screw (G₁). Slide work stop on rod and secure with set screw.

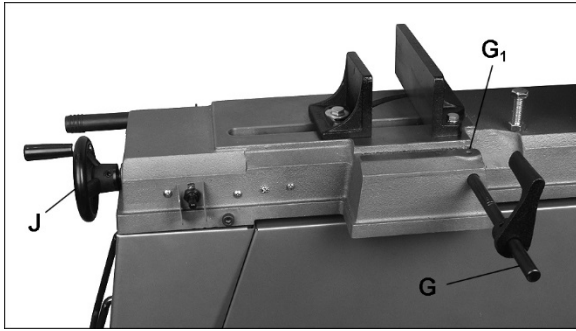

Figure 5

4. Slide pulley cover (A, Figure 6) over pulley spindles and secure with two screws (HP1).
5. Lift up on motor base (A₂) and place belt around pulley grooves. Release motor base to allow belt to tension. Tighten nut (A₃) on motor base to secure belt tension.

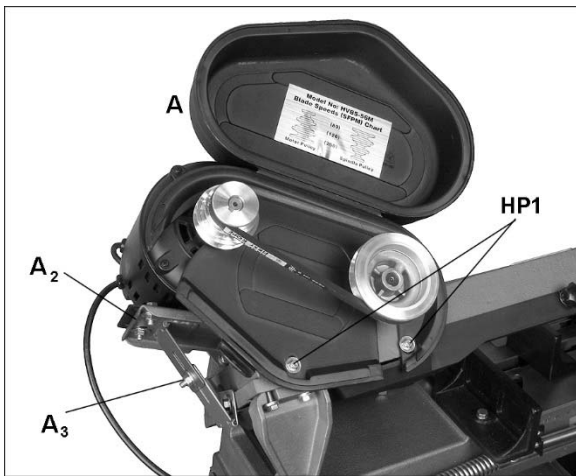

Figure 6

5.7 Vertical cutting plate

NOTE: The following steps apply only when using band saw in vertical mode.

1. Disconnect band saw from power source.
2. Raise bow to vertical position and use support (R, Figure 7) to secure in position. (If support will not slide into recess, vertical stop may need adjustment. See sect. 7.12)
3. Loosen bolt (S, Figure 7) just enough to slide stand (E) behind bolt. Tighten bolt just enough to hold stand in position.
4. Remove two flat head screws (T) and bearing guard (U). [Note: Bearing guard (U) must be reinstalled when returning to horizontal mode.]
5. Guide blade through slot in vertical cutting plate (D, Figure 7) and fasten cutting plate with the two screws.
6. Fasten stand (E) to underside of table using screw and hex nut (HP6/7). Bracket may need to be bent slightly to accommodate plate.
7. Tighten bolt (S).

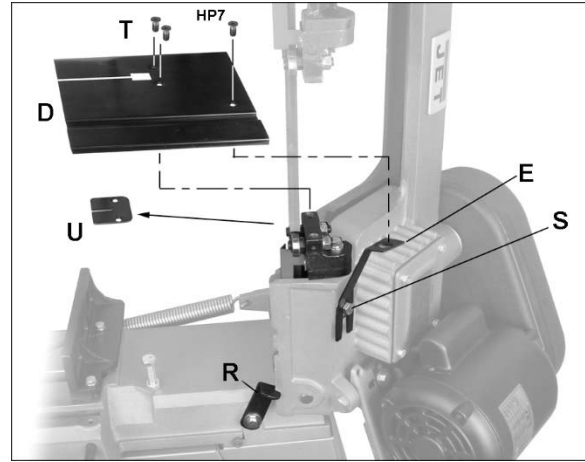

Figure 7

6.0 Electrical connections

The HVBS-56 Band Saw is rated at 115/230V power, and is pre-wired for 115 volt. The band saw comes with a plug designed for use on a circuit with a *grounded outlet* that looks like the one pictured in A, Figure 8.

Before connecting to power source, be sure switch is in *off* position.

It is recommended that the band saw be connected to a dedicated 15 amp circuit with circuit breaker or fuse. If connected to a circuit protected by fuses, use time delay fuse marked "D". **Local codes take precedence over recommendations.**

6.1 GROUNDING INSTRUCTIONS

This machine must be grounded. In the event of a malfunction or breakdown, grounding provides a path of least resistance for electric current to reduce the risk of electric shock. This tool is equipped with an electric cord having an equipment-grounding conductor and a grounding plug. The plug must be plugged into a matching outlet that is properly installed and grounded in accordance with all local codes and ordinances.

Do not modify the plug provided - if it will not fit the outlet, have the proper outlet installed by a qualified electrician.

Improper connection of the equipment-grounding conductor can result in a risk of electric shock. The conductor with insulation having an outer surface that is green with or without yellow stripes is the equipment-grounding conductor. If repair or replacement of the electric cord or plug is necessary, do not connect the equipment-grounding conductor to a live terminal.

⚠WARNING Check with a qualified electrician or service personnel if the grounding instructions are not completely understood, or if in doubt as to whether the tool is properly grounded. Failure to comply may cause serious or fatal injury.

Use only 3-wire extension cords that have 3-prong grounding plugs and 3-pole receptacles that accept the tool's plug.

Repair or replace damaged or worn cord immediately.

When operated at 115-volt, this tool is intended for use on a circuit that has an outlet that looks like the one illustrated in **A**, Figure 8. An adapter, shown in **B** and **C**, may be used to connect this plug to a 2-pole receptacle as shown in **B** if a properly grounded outlet is not available. The temporary adapter should be used only until a properly grounded outlet can be installed by a qualified electrician. *This adapter is not permitted in Canada.* The green-colored rigid ear, lug, and the like, extending from the adapter must be connected to a permanent ground such as a properly grounded outlet box.

When operated at 230-volt, this tool is intended for use on a circuit that has an outlet that looks like the one illustrated in **D**, Figure 8. The tool has a grounding plug that looks like the plug illustrated in **D**. Make sure the tool is connected to an outlet having the same configuration as the plug. No adapter is available or should be used with this tool. If the tool must be reconnected for use on a different type of electric circuit, the reconnection should be made by qualified service personnel; and after reconnection, the tool should comply with all local codes and ordinances.

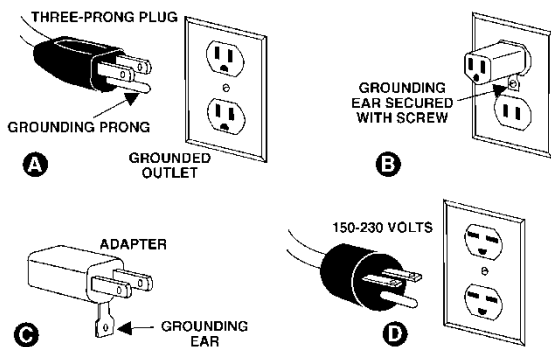

Figure 8

6.2 Voltage conversion

Conversion from 115V to 230V must be done by a qualified electrician.

The Band Saw is prewired for 115 volt. To change incoming power leads for 230 volt operation, follow wiring diagrams on inside cover of motor junction plate (Figure 9). These diagrams are also shown in Figures 10 and 11.

The plug on the end of the power cord must be replaced with a UL/CSA listed plug rated for 230 volt operation.

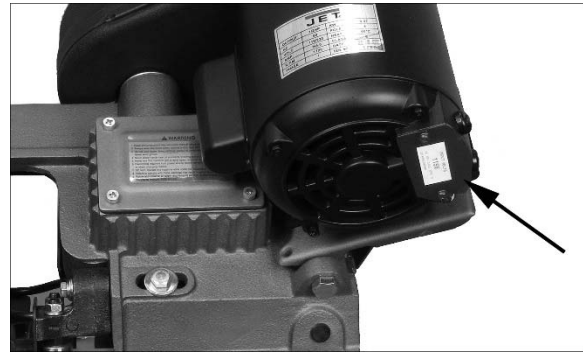

Figure 9

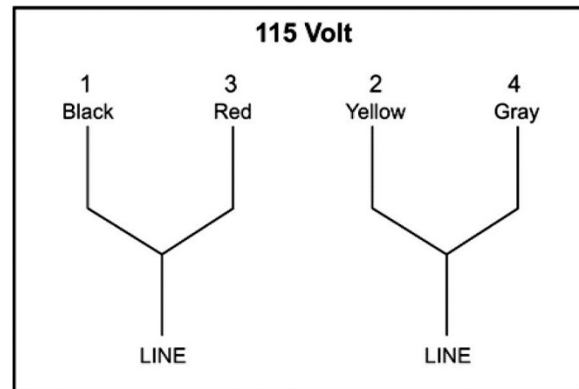

Figure 10

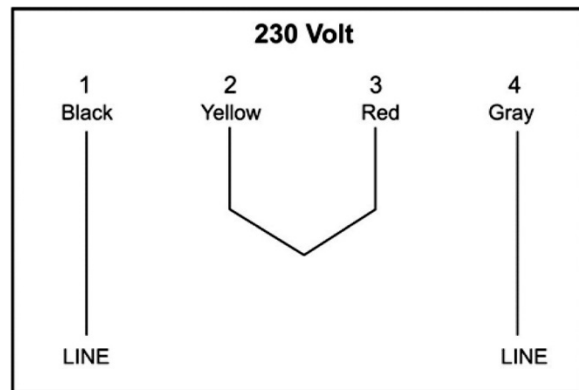

Figure 11

6.3 Extension cords

The use of extension cords is discouraged; try to position machines near the power source. If an extension cord is necessary, make sure it is in good condition. When using an extension cord, be sure to use one heavy enough to carry the current your product will draw. An undersized cord will cause a drop in line voltage resulting in loss of power and overheating. Table 1 shows correct size to use depending on cord length and nameplate ampere rating. If in doubt, use the next heavier gauge. The smaller the gauge number, the heavier the cord.

Ampere Rating		Volts	Total length of cord in feet			
More Than	Not More Than		25	50	100	150
		120	25	50	100	150
		240	50	100	200	300
			AWG			
0	6		18	16	16	14
6	10		18	16	14	12
10	12		16	16	14	12
12	16		14	12	Not Recommended	

Table 1: Extension cord recommendations

7.0 Adjustments

⚠WARNING Disconnect band saw from power source before making adjustments.

7.1 Tools required for adjustments

(Not all may be needed depending on adjustment.)
 Wrenches 12,14,16mm
 Hex key 4mm
 Square
 Straight edge
 Small clamp

7.2 Blade speed adjustment

1. Disconnect band saw from power source.
2. Place bow in horizontal position.
3. Loosen tensioning plate hex nut (A, Figure 12).



Figure 12

4. Open pulley cover. Lift motor with one hand while placing belt on desired pulley combination. Refer to chart inside pulley cover or Figure 13.
5. Tension belt by pressing down on motor while tightening hex nut (A) until finger pressure on the belt between the two pulleys causes approximately 1/2-inch deflection. Do not overtighten belt.

6. Close pulley cover and connect to power source.

General rule for band saw blade speed: The harder the material being cut, the slower the blade speed. Refer to Table 2 for blade speed recommendations.

Material	Speed (SFPM)*	Motor pulley	Spindle pulley
Tool, Stainless, or Alloy Steel, Bearing Bronzes	80 SFPM	Small	Large
Mild Steel, Hard Brass, or Bronze	120 SFPM	Medium	Medium
Soft Brass, Aluminum, or other light materials	200 SFPM	Large	Small

*SFPM = surface feet per minute

Table 2: Speed recommendations

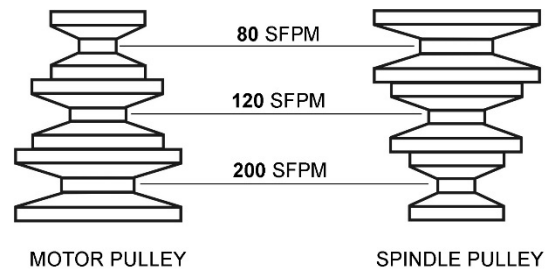

Figure 13

7.3 Blade guide adjustment

1. Disconnect band saw from power source.
2. Loosen handle (B, Figure 14) and slide left blade guide assembly (C) as close as possible without interference to material being cut. Tighten knob.
3. Loosen bolt (D) and slide right blade guide assembly (E) as close as possible, without interference, to material being cut. Tighten bolt.

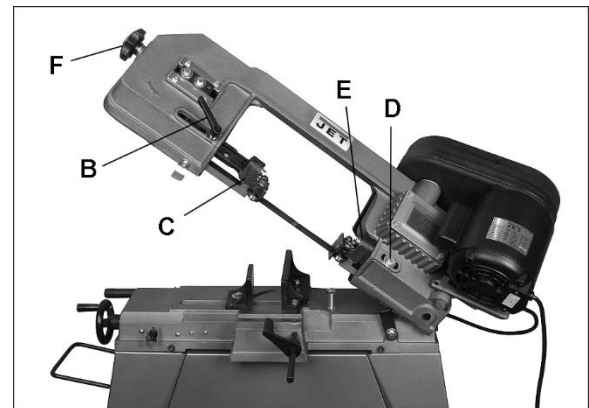

Figure 14

7.4 Blade tension

1. Disconnect band saw from power source.
2. Open blade cover by removing knob and 2 screws (G, Figure 15). Observe position of blade on wheel. If blade is not adjacent to wheel flange, adjust blade tracking according to sect. 7.7, *Blade tracking*.
3. If blade is adjacent to wheel flange, loosen blade guide assembly handle and bolt (B and D, Figure 14) and slide blade guide assemblies as far apart as possible. Lock in place.
4. Push on blade to test tension. Finger pressure should cause approximately 0.004" deflection. Turn blade tension knob (F, Figure 15) until proper tension is achieved. Reposition guides for cutting material.

7.5 Blade changes

1. Disconnect band saw from power source.
2. Raise bow to vertical position and secure in place with support.
3. Open blade cover.
4. Remove red blade guards by removing two screws.

⚠ WARNING It is essential these red guards be installed after new blade has been fitted. Failure to comply may cause serious injury.

5. Release tension on blade by turning tensioning knob (F, Figure 15). Remove blade.

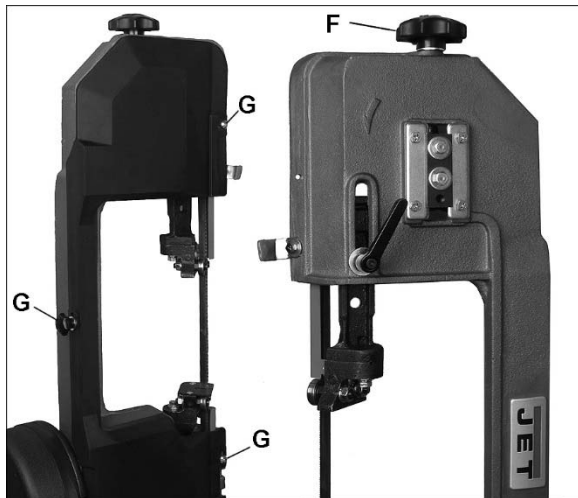

Figure 15

6. Place new blade between blade guide assemblies and around each wheel. Make sure blade teeth are pointing in proper direction (Figure 16). Tension enough to hold in place.

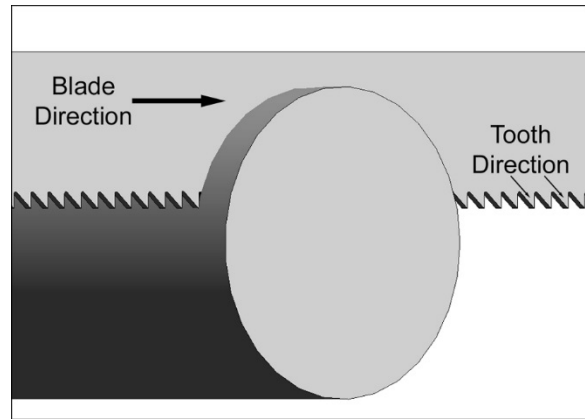

Figure 16

7. Install red blade guards with screws.
8. Tension blade fully (see sect. 7.4 *Blade tension*.)
9. Place 2 to 3 drops of lightweight oil on blade.
10. Connect machine to power source.
11. Run saw and make sure blade is tracking properly (sect. 7.7, *Blade tracking*.)
12. As a general rule, the thinner the material to be cut, the more teeth per inch on the blade. A minimum of three teeth should be in contact with the material at all times during the cut. If the teeth straddle the material, severe damage can result to material and blade.
13. Follow blade break-in procedures, sect. 8.1.

7.6 Blade guide bearings

1. Disconnect band saw from power source.
2. Loosen bolt (H, Figure 17) and adjust assembly so that rear bearing (J) is approximately 0.002 to 0.003 inches from back of blade. Also, inside bearing (K) should very lightly contact blade. Tighten bolt (H).

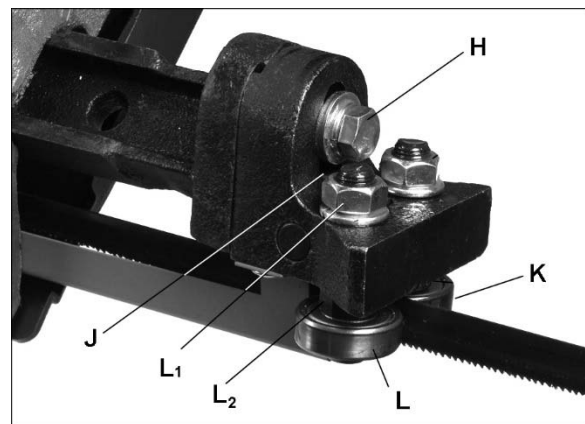

Figure 17

3. Inside bearing (K) is fixed. Outside bearing (L) rotates on an eccentric shaft. Loosen top nut (L₁) and rotate bottom nut (L₂) to adjust eccentric bearing to a clearance of 0.001 inches from blade.

4. Hold bottom nut (L₂) to prevent it turning further, and retighten top nut (L₁).
5. Repeat above steps for opposite blade guide assembly.

7.7 Blade tracking

⚠WARNING Blade tracking adjustment requires running saw with back cover open. This adjustment must be completed by qualified persons only. Failure to comply may cause serious injury.

Blade tracking has been set by the manufacturer and should not need immediate adjustment. If blade tracking should ever require adjustment:

1. Confirm that blade tension is set properly. To adjust, see *sect. 7.4, Blade tension*.
2. Set saw to lowest speed (*sect. 7.2*).
3. Raise bow to vertical position and secure in place with support (R, Figure 7).
4. Confirm that blade tension is set properly. To adjust, see *sect. 7.4, Blade tension*.
5. Open blade cover.
6. Run saw and observe blade. Blade should run next to but not tightly against wheel flange.
7. Loosen bolts (M, Figure 18) with 12mm wrench.
8. Turn set screw (N) with 4mm hex key, while observing blade tracking on wheel. Turn set screw clockwise to track closer to wheel flange. Turn set screw counterclockwise to track away from wheel flange. **NOTE:** This adjustment is sensitive; start with 1/4 turns on the set screw and allow blade to respond to changes.
9. Once tracking is set, tighten bolts (M).

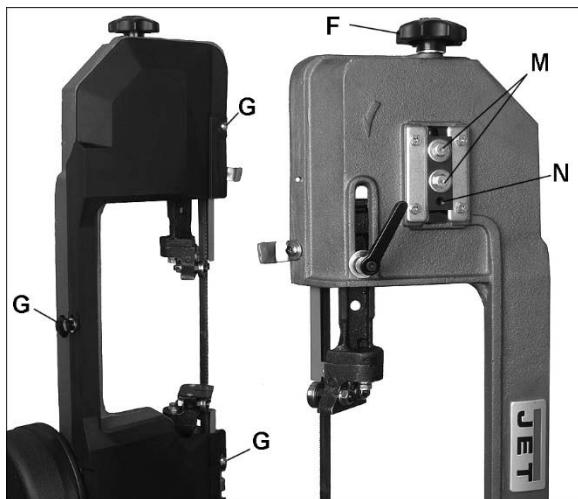

Figure 18

7.8 Feed pressure adjustment

Turn handle (O, Figure 19) clockwise to decrease feed pressure; counterclockwise to increase feed pressure.

A good indication of proper feed pressure is the color and shape of the cutting chips. If the chips are thin or powdered, increase feed pressure. If the chips are burned and heavy, decrease feed pressure. If they are still burned and heavy, reduce blade speed. Optimum feed pressure has been set when the chips are curled, silvery, and warm.

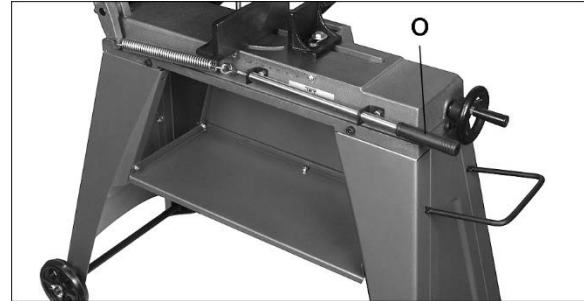

Figure 19

7.9 Blade-to-table squareness

The blade must be perpendicular to table to ensure a straight cut. This setting should be checked. Special blade setting gauges can be purchased for this type of inspection; however, it can also be done using more common shop items, as follows.

1. “Extend” the surface of blade by clamping a straight, flat object to blade. (Figure 20 uses a small, lightweight aluminum ruler.) Use a lightweight clamp.

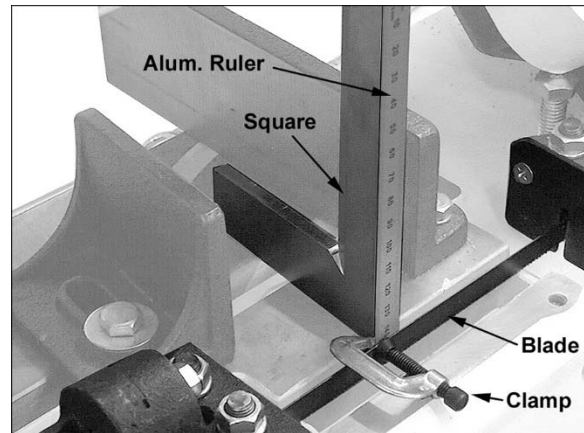

Figure 20

2. Place a square on table and against ruler. The square should lie flat against ruler without a gap.
3. If there is a gap, loosen bolt (H, Figure 17) on each blade guide assembly and rotate blade guide assembly until gap is eliminated between square and ruler.
4. Retighten bolts (H, Figure 17).

- After making this adjustment, be sure to re-check other blade adjustments as noted in this manual.

7.10 Auto shut-off adjustment

The saw is properly adjusted when blade shuts off just after cut completion. To set this:

- If saw completes cut but blade continues moving, adjust switch trip (P, Figure 21) downward.
- If blade stops before cut is complete, adjust switch trip (P) upward.
- If blade stops descending and continues running without completing the cut, turn stop bolt (Q) down.

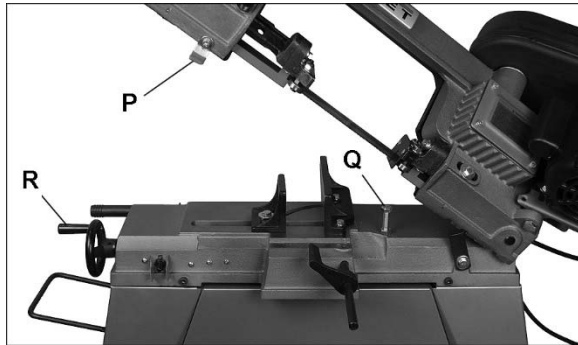

Figure 21

7.11 Vise adjustment

Use handwheel (R, Figure 21) to open and close vise.

Vise can be adjusted for square and miter cuts. Loosen hex cap bolts and adjust vise for the cut.

Slightly loosen screw on floating vise (14mm wrench) to allow it to conform to tapered or irregular-shaped pieces. Then tighten screw before operating.

A scale on back side of bed aids in positioning vise for 90° cuts or a particular miter. **TIP:** Always verify vise position by using a square against blade and vise.

7.12 Vertical stop adjustment

The stop screw (Figure 22) can be adjusted to ensure bow is at 90-degrees when using vertical cutting plate.

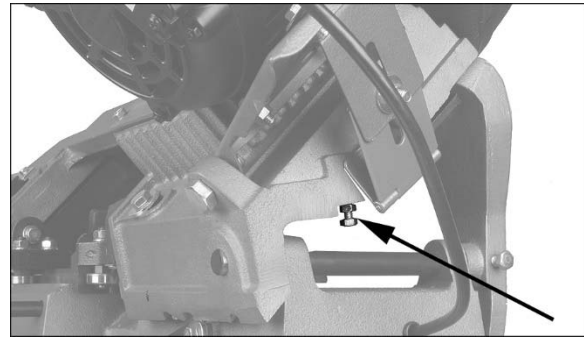

Figure 22

8.0 Operation

8.1 Blade break-in

New blades are very sharp and, therefore, have a tooth geometry which is easily damaged if a careful break-in procedure is not followed. Consult the blade manufacturer's literature for break-in of specific blades on specific materials. However, the following procedure will be adequate for break-in of JET-supplied blades on lower alloy ferrous materials.

- Clamp a round section workpiece in the vise. The workpiece should be 2 inches or larger in diameter.
- Set the saw on low speed. Start the cut with a very light feed rate.
- When the saw has completed 1/3 of the cut, increase feed rate slightly and allow saw to complete the cut.
- Keep the same hydraulic cylinder setting and begin a second cut on the same or similar workpiece.
- When blade has completed about 1/3 of cut, increase feed rate. Watch chip formation until cutting is at its most efficient rate and allow saw to complete the cut (see sect. 8.3, *Evaluating cutting efficiency*).
- The blade is now ready for regular service.

8.2 General operating procedure

- Raise bow and secure in position using support, as shown in Figure 21.

CAUTION Always secure bow in raised position with support plate before loading material. Never start a cut with blade contacting workpiece.

- Position workpiece in vise and tighten vise. Workpiece should be fitted directly between jaws without adding other objects. When workpiece is profiled section, flat piece or special shape, refer to examples in Figure 23 for proper clamping positions. The top row

shows acceptable clamping positions, the bottom row shows **un**acceptable positions.

If the thickness of profile section is very thin, a piece which duplicates the profile should be fitted inside the workpiece itself, to prevent workpiece being crushed between the jaws.

⚠WARNING Do not load/unload material from vise while machine is running. Never hold workpiece by hand when cutting; workpiece must be firmly secured in vise. Do not reach into cutting area during cutting operations.

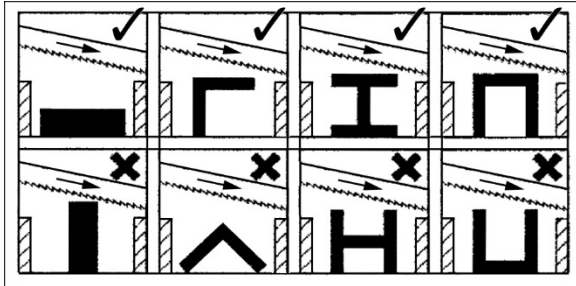

Figure 23: clamping positions

3. Adjust blade guides to minimize exposed blade area.
4. Release support and turn on saw. Lower bow until blade contacts material. Release bow to allow cutting to proceed. Weight of bow in conjunction with spring tension will force blade through material until cut is finished.
5. Switch trip tab must turn off saw at completion of cut.

8.3 Evaluating cutting efficiency

Is the blade cutting efficiently? The best way to determine this is to observe the chips formed by the cutting.

If chip formation is powdery, then the feed rate is much too light, or the blade is dull.

If chips are curled, but colored — that is, either blue or straw-colored from heat generated during the cut — then the feed rate is too high.

If chips are slightly curled and are not colored by heat, the blade is sufficiently sharp and is cutting at its most efficient rate.

9.0 User-maintenance

⚠WARNING Always disconnect power to the machine before performing maintenance. Failure to do this may result in serious personal injury.

Wipe down saw with a soft rag after each use, and clear metal particles with a small paint brush or parts cleaning brush. Do not use compressed air, as it

may force chips into the guide bearings and other critical areas of saw.

Periodically apply a light coat of oil on exposed metal surfaces to inhibit rust.

Make frequent inspections of motor fan, and blow out (with low pressure air hose) or vacuum any accumulation of foreign material to maintain normal motor ventilation.

Keep blade guides clean and free of metal particles.

Check guide bearings frequently to make sure that they are properly adjusted and turning freely.

Periodically inspect belt for wear or fraying. Replace if needed.

Inspect power cord; if worn, cut or damaged in any way, have it replaced immediately.

9.1 Lubrication

Ball bearings on blade guide assemblies and blade wheels are permanently lubricated and sealed, and should require no further lubrication.

Lubricate the vise lead screw as needed with #2 tube grease.

Drain and refill gear box oil after first 90 days of operation. Thereafter, change every six months. Use MOBIL SHC 634 or equivalent.

To change gear box oil:

1. Disconnect machine from power source.
2. Place bow in horizontal position. Loosen or remove screw and nut on motor tension plate (see A, Figure 12). Remove drive belt and allow motor to drop away, for access to gearbox.
3. Remove four screws from gear box (Figure 24) and remove cover plate and gasket.
4. Hold a container under lower right corner of gear box with one hand while slowly raising bow with the other. Drain completely.
5. Place arm in horizontal position. Wipe out remaining oil with a rag.
6. Fill gear box with approximately 1/2 pint of MOBIL SHC 634.
7. Replace gasket and cover. Fasten cover with screws.
8. Reinstall and tension drive belt, and secure nut on tension plate (A, Figure 12).

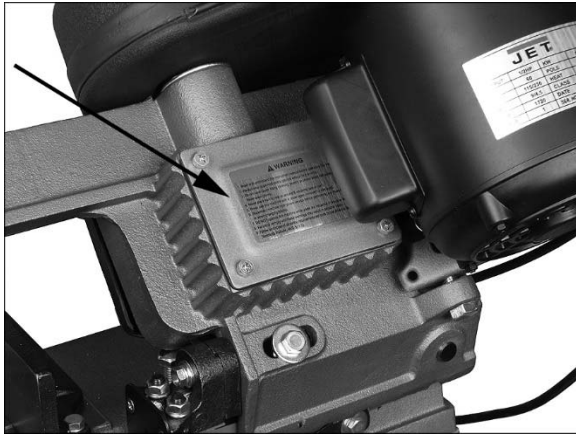

Figure 24

9.2 Additional servicing

Any additional servicing on the band saw should be performed by an authorized service representative.

10.0 Troubleshooting HVBS-56 Band Saw

10.1 Mechanical and electrical problems

Symptom	Possible Cause	Correction *
Motor will not start.	Low voltage.	Check power line for proper voltage.
	Open circuit in motor or loose connection.	Inspect all lead connections on motor for loose or open connections.
Motor will not start, or motor stalls, resulting in blown fuse or tripped breaker.	Too many tools running on one circuit.	Reduce number of tools connected to circuit.
	Short circuit in line cord or plug.	Inspect cord or plug for damaged insulation and shorted wires.
	Short circuit in motor or loose connections.	Inspect all connections on motor for loose or shorted terminals or worn insulation.
Motor overheats.	Motor overloaded.	Reduce load on motor: increase speed or decrease feed pressure.
	Air circulation through motor is restricted.	Clean motor fan with compressed air to restore normal air circulation.
Machine slows when operating.	Excessive feed pressure.	Adjust spring tension to reduce feed pressure, or increase speed using belt adjustment.
	Belt loose.	Tighten belt.
Loud, repetitive noise coming from machine.	Pulley setscrews are missing or loose.	Inspect setscrews. Replace or tighten if necessary.
	Motor fan is hitting the cover.	Tighten fan or shim cover.
	V-belt is defective.	Replace V-belt.

* **WARNING:** Some corrections may require a qualified electrician.

10.2 Operational problems

Symptom	Possible Cause	Correction
Cuts not square.	Blade not square to vise/material.	Adjust vise square to blade.
	Blade surface not perpendicular to table.	Adjust blade guides until perpendicular.
	Workpiece shifting in vise.	Properly secure workpiece.
	Low blade tension.	Increase tension.
	Blade guides out of adjustment.	Adjust blade guides.
Premature dulling of blade teeth	Improper blade break-in.	Follow proper break-in procedure.
	Excessive blade speed, blade teeth overheating.	Decrease speed.
	Improper tooth pitch for material.	Use proper blade.
Rough cut.	Improper blade break-in.	Follow proper break-in procedure.
	Improper speed or feed rate.	Adjust as needed.
	Dull or damaged teeth.	Replace blade.
	Poor weld on blade.	Replace or re-weld blade.

11.0 Replacement Parts

Replacement parts are listed on the following pages. To order parts or reach our service department, call 1-800-274-6848 Monday through Friday, 8:00 a.m. to 5:00 p.m. CST. Having the Model Number and Serial Number of your machine available when you call will allow us to serve you quickly and accurately.

Some parts are shown for reference only, and may not be available individually.

Non-proprietary parts, such as fasteners, can usually be found at local hardware stores or may be ordered from JET.

11.1.1 HVBS-56 Bow Assembly – Exploded View

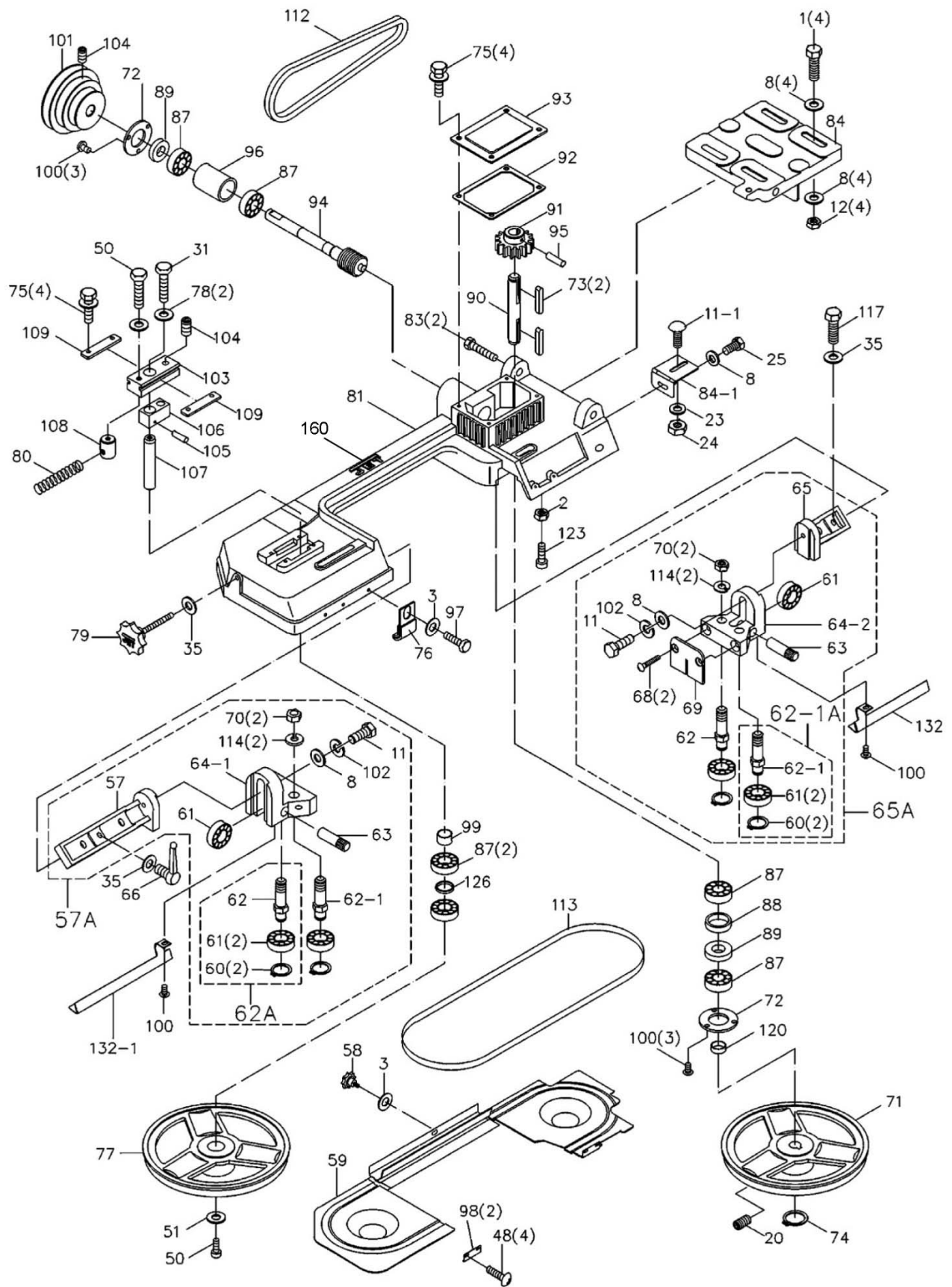

11.1.2 HVBS-56 Bed Assembly – Exploded View

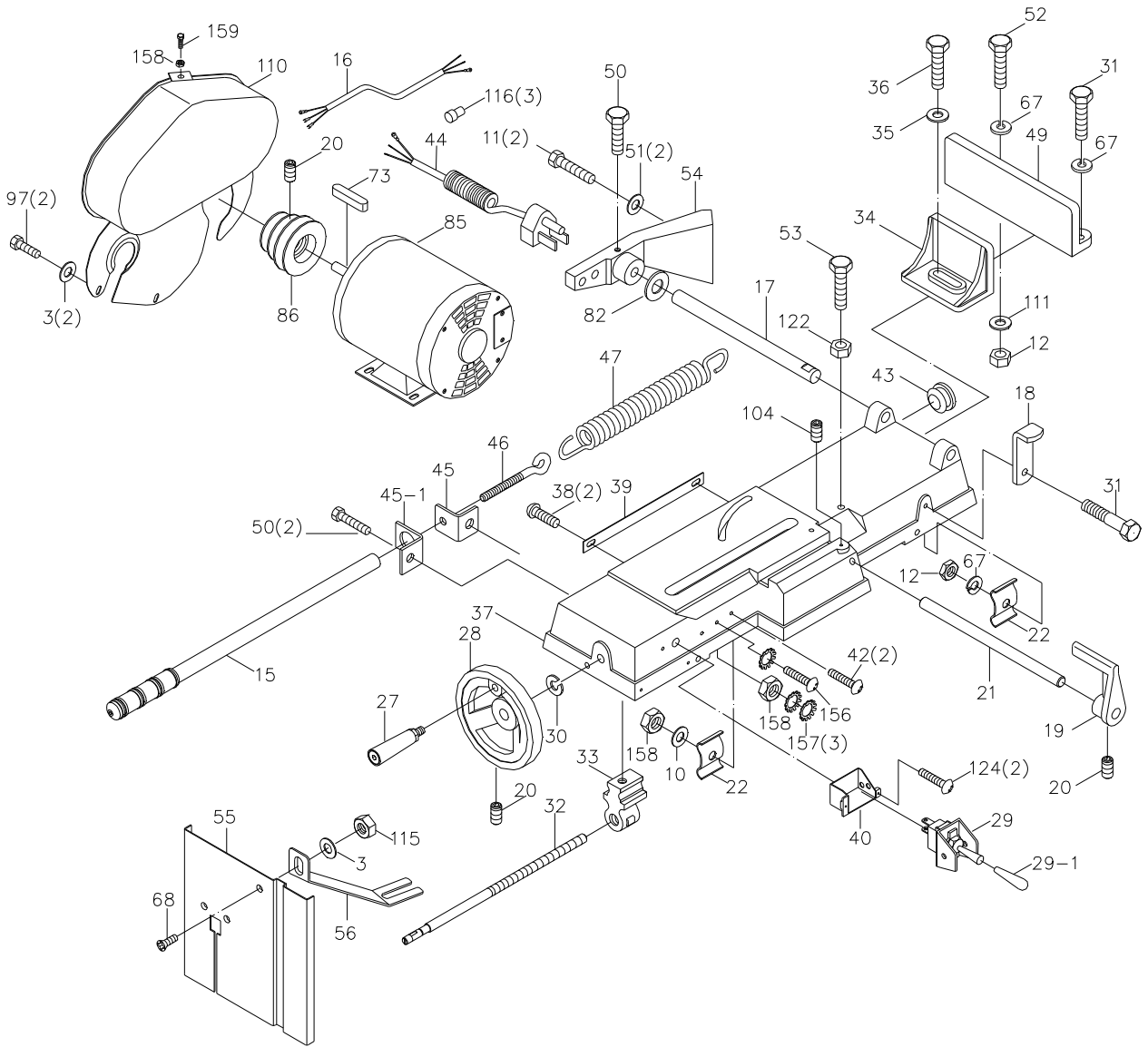

11.1.3 HVBS-56 – Bow and Bed Assemblies Parts List

Index No	Part No	Description	Size	Qty
1	TS-0051031	Hex Cap Bolt	5/16"x3/4"	4
2	TS-0561011	Hex Nut	1/4"	1
3	TS-0680021	Flat Washer	1/4"	3
8	TS-0680031	Flat Washer	5/16"	10
10	HVBS56M-010	Washer	1/4"x5/8"	1
11	TS-0051051	Hex Cap Bolt	5/16"x1"	4
11-1	HVBS56M-11-1	Carriage Bolt	5/16"x 3/4"	1
12	TS-0561021	Hex Nut	5/16"	6
15	HVBS462-015	Adjusting Rod		1
16	HVBS462-016	Electric Cord		1
17	HVBS462-017	Pivoting Rod		1
18	HVBS462-018	Support Plate		1
19	HVBS462-019	Stock Stop		1
20	TS-0270021	Socket Set Screw	5/16"x5/16"	4
21	HVBS462-021	Stock Stop Rod		1
22	HVBS462-022	Wire Relief Retainer		2
23	TS-0680031	Flat Washer	5/16"	1
24	TS-0561021	Hex Nut	5/16"	1
25	TS-0051031	Hex Cap Bolt	5/16"x3/4"	1
27	HVBS462-027	Wheel Handle		1
28	HVBS462-028	Handwheel		1
29	HVBS56M-029	Toggle Switch Assembly		1
29-1	HVBS56M-029-1	Plastic Cover		1
30	HVBS462-030	E-Ring	E10	1
31	HVBS462-031	Screw	5/16"x1"	3
32	HVBS462-032	Lead Screw		1
33	HVBS462-033	Vise Nut		1
34	HVBS462-034	Moveable Vise Plate		1
35	TS-0680041	Flat Washer	3/8"x1"	2
36	TS-0090061	Hex Cap Bolt	3/8"x1-1/4"	1
37	HVBS462-037G	Bed		1
38	HVBS462-038	Cross Round Head Screw	3/16"x3/8"	2
39	HVBS462-039	Scale		1
40	HVBS462-040	Electric Cord Clip		1
42	HVBS56M-042	Screw	M4x16	2
43	HVBS462-043	Rubber Ring		1
44	HVBS462-044	Electric Cable		1
45	HVBS462-045	Nut Plate		1
45-1	HVBS56M-045-1	Spring Handle Bracket		1
46	HVBS462-046	Spring Adjusting Screw		1
47	HVBS462-047	Spring		1
48	HVBS462-048	Cross Round Head Screw	3/16"x3/8"	4
49	HVBS462-049	Mitering Vise Plate		1
50	TS-0081031	Hex Cap Bolt	5/16"x3/4"	5
51	TS-0680031	Flat Washer	5/16"	3
52	TS-0081071	Hex Cap Bolt	5/16"x1-1/2"	1
53	TS-0091071	Hex Cap Screw	7/16"x2"	1
54	HVBS56M-054G	Pivot Bracket		1
55	HVBS462-055	Vertical Cutting Plate		1
56	HVBS462-056	Stand for Vertical Cutting Plate		1
57	HVBS56M-057	Adjustable Bracket LH		1
57A	HVBS56M-057A	Adjustable Bracket Assembly LH		1
58	HVBS462-058	Knob	1/4"	1
59	HVBS56M-380	Blade Back Safety Cover		1
60	HVBS462-060	C-Clip	S10	4
61	BB-6000ZZ	Ball Bearing	6000ZZ	6
62	HVBS462-062	Guide Pivot		2
62A	HVBS462-062A	Center Shaft Assembly (Includes: #60-62)		1
62-1	HVBS462-062-1	Centrifugal Guide Pivot		2
62-1A	HVBS462-062-1A	Eccentric Shaft Assembly (Includes: #60,61,62-1)		1

Index No	Part No	Description	Size	Qty
63	HVBS462-063	Bearing Shaft Pin		2
64-1	HVBS462-064-1	Blade Seat Left		1
64-2	HVBS462-064-2	Blade Seat Right		1
65	HVBS56M-065	Adjustable Bracket-RH		1
65A	HVBS56M-065A	Adjustable Bracket-Assembly RH		1
66	HVBS56M-066	Lock Knob		1
67	TS-0720081	Lock Washer	5/16"	3
68	TS-0813051	Flat Head Machine Screw *	1/4"x3/4"	3
69	HVBS462-069	Bearing Guard		1
70	TS-0561032	Hex Nut	3/8-24 UNF	4
71	HVBS462-071	Drive Blade Wheel		1
72	HVBS462-072	Bearing Cover		2
73	HVBS462-073	Key	5x5x25	3
74	HVBS56M-060	C-Clip	S15	1
75	HVBS462-075	Hex Cap Bolt (w/Washer)	1/4"x1/2"	8
76	HVBS462-076	Switch Cut Off Trip		1
77	HVBS462-077	Idle Blade Wheel		1
78	TS-0680031	Flat Washer	5/16"	2
79	HVBS462-079	Blade Tension Knob	3/8"	1
80	HVBS462-080	Spring		1
81	HVBS56M-081G	Saw Bow		1
82	HVBS56M-082	Washer		1
83	TS-0070031	Hex Cap Screw	1/2"x1-1/2"	2
84	HVBS56M-084G	Motor Mount Plate		1
84-1	HVBS56M-084-1	Tension Bracket		1
85	HVBS463-085	Motor	1/2 HP, 1Ph	1
	HVBS463-085-01	Capacitor Cover (not shown)		1
	HVBS462-085-02	Capacitor (not shown)		1
86	HVBS462-086	Motor Pulley		1
87	BB-6202ZZ	Ball Bearing	6202ZZ	6
88	HVBS462-088	Bearing Bushing		1
89	OS-15375	Oil Seal		2
90	HVBS462-090	Transmission Wheel Shaft		1
91	HVBS462-091	Worm Gear		1
92	HVBS462-092	Gear Box Gasket		1
93	HVBS462-093G	Gear Box Cover		1
94	HVBS462-094	Worm Gear (w/Shaft)		1
95	HVBS462-095	Spring Pin		1
96	HVBS462-096	Bearing Bushing		1
97	TS-0050011	Hex Cap Bolt	1/4"x1/2"	2
98	HVBS56M-098	Clamp		2
99	HVBS462-099	Spacer		1
100	HVBS462-100	Flat Cross Head Screw	5/32"x3/8"	8
101	HVBS462-101	Worm Gear Pulley		1
102	TS-0720081	Lock Washer	5/16"	2
103	HVBS462-103	Blade Tension Sliding Plate		1
104	TS-0270051	Socket Set Screw	5/16"x1/2"	3
105	HVBS462-105	Spring Pin		1
106	HVBS462-106	Sliding Plate Draw Block		1
107	HVBS462-107	Blade Wheel Shaft		1
108	HVBS462-108	Shaft Block		1
109	HVBS462-109	Blade Tension Sliding Guide		2
110	HVBS462-110	Motor Pulley Cover Assembly		1
111	TS-0680031	Flat Washer	5/16"	1
112	VB-A22	V-Belt	A22	1
113	414301	Blade		1
114	TS-0680041	Flat Washer	3/8"	4
115	TS-0561011	Hex Nut *	1/4"	1
116	HVBS463-170	Wire Plug		3
117	HVBS463-171	Hex Cap Screw	3/8"x1-1/4"	1
120	HVBS462-120	Bushing		1
122	TS-0561041	Hex Nut	7/16"	1

Index No	Part No	Description	Size	Qty
123	TS-0050031	Cap Screw	1/4"x3/4"	1
124	HVBS463-124	Machine Screw	3/16"x3/4"	2
126	HVBS462-126	Bushing		1
132	HVBS462-132	Blade Guard-Right		1
132-1	HVBS462-132A	Blade Guard-Left		1
156	HVBS462-156	Round Head Screw	3/16"x3/4"	1
157	HVBS462-157	Star Washer	3/16"	3
158	HVBS463-158	Hex Nut	3/16"	2
159	HVBS463-159	Round Cross Head Screw	3/16"x1/2"	1
160	JET-92	JET Logo with 3M adhesive	92 x 38 mm	1
	JJ6CS-OEW2	Open End Wrench (not shown)	12/14 mm	1
	HVBS56M-BS	Blade Speed Label (not shown)		1
	HVBS56M-ID	I.D. Label (not shown)		1
	HVBS56M-WL	Warning Label (not shown)		1
	HVBS56MG-HP	Hardware Package (contains items with *)		1

11.2.1 HVBS-56 Stand – Exploded View

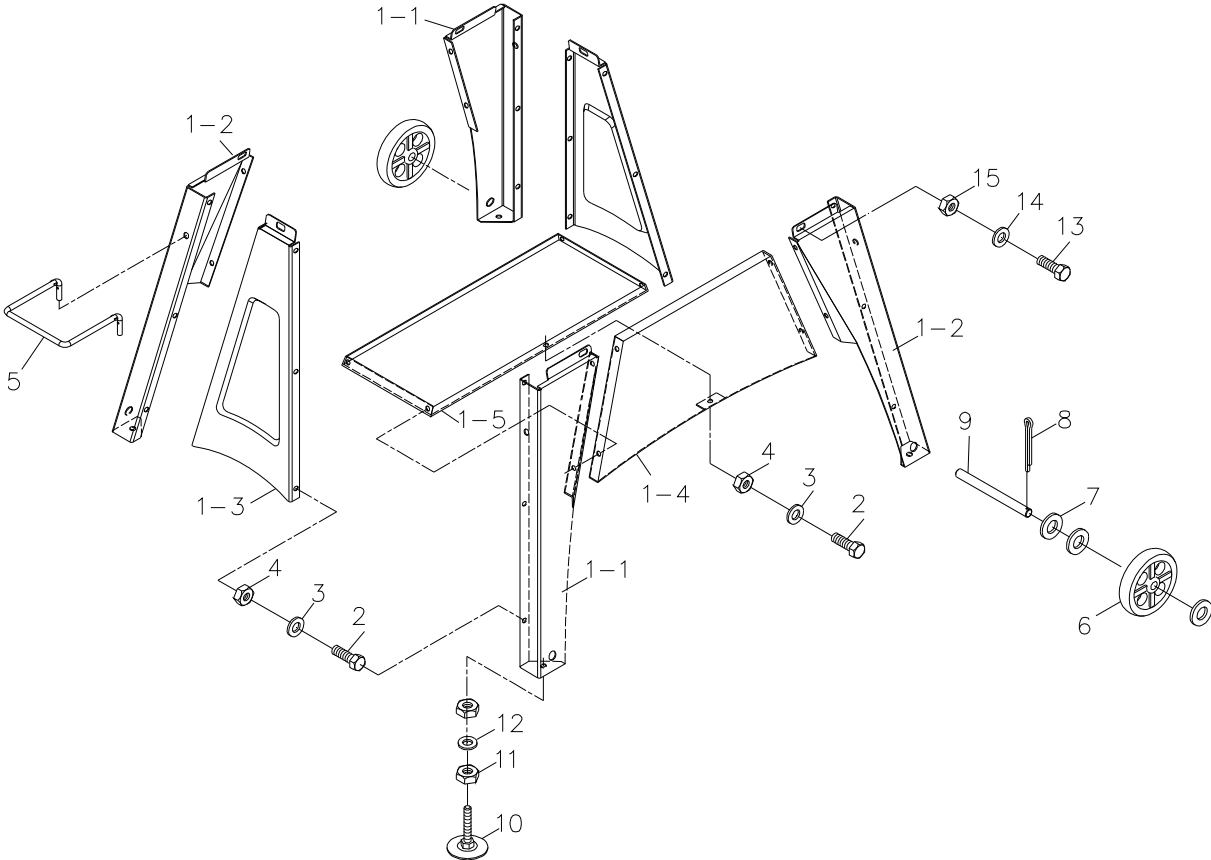

11.2.2 HVBS-56 Stand – Parts List

Index No	Part No	Description	Size	Qty
1	HVBS56M-CSA	Complete Stand Assembly		1
1-1	HVBS56M-S1	Left Stand Leg		2
1-2	HVBS56M-S2	Right Stand Leg		2
1-3	HVBS56M-S3	Cross Brace		2
1-4	HVBS56M-S4	Front Panel		1
1-5	HVBS56M-S5	Shelf		1
2	HVBS56M-2	Phillips Head Screw w/lock washer *	1/4" x 5/8"	19
3	TS-0680021	Flat Washer *	1/4"	19
4	TS-0570011	Hex Nut *	1/4"-20	19
5	HVBS462-014	Floor Stand Handle		1
6	HVBS56M-09	Wheel		2
7	TS-0680081	Flat Washer *	5/8"	6
8	HVBS462-006	Cotter Pin *	1/8" x 1"	2
9	HVBS56M-07	Axle		1
10	HVBS56M-013	Adjustable Foot	3/8"	2
11	TS-0561032	Hex Nut	3/8"UNF	4
12	TS-0680041	Flat Washer	3/8"	2
13	TS-0208071	Socket Head Cap Screw *	5/16"-18 x 1-1/4"	6
14	TS-0680031	Flat Washer *	5/16"	6
15	TS-0570021	Hex Nut *	5/16"-18	6
	HVBS56MG-HP	Hardware Package (contains items with *)		

12.0 Electrical Connections – HVBS-56 Band Saw

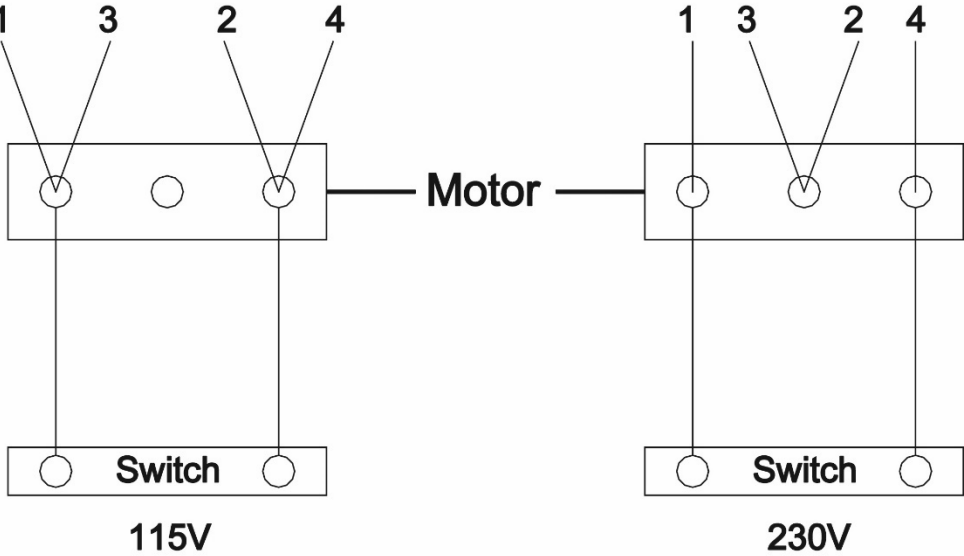

13.0 Warranty and service

JET warrants every product it sells against manufacturers' defects. If one of our tools needs service or repair, please contact Technical Service by calling 1-800-274-6846, 8AM to 5PM CST, Monday through Friday.

Warranty Period

The general warranty lasts for the time period specified in the literature included with your product or on the official JET branded website.

- JET products carry a limited warranty which varies in duration based upon the product. (See chart below)
- Accessories carry a limited warranty of one year from the date of receipt.
- Consumable items are defined as expendable parts or accessories expected to become inoperable within a reasonable amount of use and are covered by a 90 day limited warranty against manufacturer's defects.

Who is Covered

This warranty covers only the initial purchaser of the product from the date of delivery.

What is Covered

This warranty covers any defects in workmanship or materials subject to the limitations stated below. This warranty does not cover failures due directly or indirectly to misuse, abuse, negligence or accidents, normal wear-and-tear, improper repair, alterations or lack of maintenance. JET woodworking machinery is designed to be used with Wood. Use of these machines in the processing of metal, plastics, or other materials outside recommended guidelines may void the warranty. The exceptions are acrylics and other natural items that are made specifically for wood turning.

Warranty Limitations

Woodworking products with a Five Year Warranty that are used for commercial or industrial purposes default to a Two Year Warranty. Please contact Technical Service at 1-800-274-6846 for further clarification.

How to Get Technical Support

Please contact Technical Service by calling 1-800-274-6846. **Please note that you will be asked to provide proof of initial purchase when calling.** If a product requires further inspection, the Technical Service representative will explain and assist with any additional action needed. JET has Authorized Service Centers located throughout the United States. For the name of an Authorized Service Center in your area call 1-800-274-6846 or use the Service Center Locator on the JET website.

More Information

JET is constantly adding new products. For complete, up-to-date product information, check with your local distributor or visit the JET website.

How State Law Applies

This warranty gives you specific legal rights, subject to applicable state law.

Limitations on This Warranty

JET LIMITS ALL IMPLIED WARRANTIES TO THE PERIOD OF THE LIMITED WARRANTY FOR EACH PRODUCT. EXCEPT AS STATED HEREIN, ANY IMPLIED WARRANTIES OF MERCHANTABILITY AND FITNESS FOR A PARTICULAR PURPOSE ARE EXCLUDED. SOME STATES DO NOT ALLOW LIMITATIONS ON HOW LONG AN IMPLIED WARRANTY LASTS, SO THE ABOVE LIMITATION MAY NOT APPLY TO YOU.

JET SHALL IN NO EVENT BE LIABLE FOR DEATH, INJURIES TO PERSONS OR PROPERTY, OR FOR INCIDENTAL, CONTINGENT, SPECIAL, OR CONSEQUENTIAL DAMAGES ARISING FROM THE USE OF OUR PRODUCTS. SOME STATES DO NOT ALLOW THE EXCLUSION OR LIMITATION OF INCIDENTAL OR CONSEQUENTIAL DAMAGES, SO THE ABOVE LIMITATION OR EXCLUSION MAY NOT APPLY TO YOU.

JET sells through distributors only. The specifications listed in JET printed materials and on official JET website are given as general information and are not binding. JET reserves the right to effect at any time, without prior notice, those alterations to parts, fittings, and accessory equipment which they may deem necessary for any reason whatsoever. JET® branded products are not sold in Canada by JPW Industries, Inc.

Product Listing with Warranty Period

90 Days – Parts; Consumable items
1 Year – Motors; Machine Accessories
2 Year – Metalworking Machinery; Electric Hoists, Electric Hoist Accessories; Woodworking Machinery used for industrial or commercial purposes
5 Year – Woodworking Machinery
Limited Lifetime – JET Parallel clamps; VOLT Series Electric Hoists; Manual Hoists; Manual Hoist Accessories; Shop Tools; Warehouse & Dock products; Hand Tools; Air Tools

NOTE: JET is a division of JPW Industries, Inc. References in this document to JET also apply to JPW Industries, Inc., or any of its successors in interest to the JET brand.