



JACKSON
SAFETY

product catalog





For 75 years, men and women have wanted Jackson Safety on the job for their safety needs. The reason is simple. When it comes to providing superior protection and durability, we set the standards. Jackson Safety has truly become a leading source for welding safety, traffic safety products and personal protective equipment. This single source approach to fulfilling multiple safety solutions has resonated with customers and resulted in a broadened identification of Jackson Safety.

Every Jackson Safety product is guaranteed to deliver long-lasting value. Because your customers need the tools they work with, you always want Jackson Safety on the Job.



Construction/Industrial Supply Distribution Network

PATENTS

Jackson Safety's welding helmets and lenses are covered by one or more of the following US patents: D310,432; D349,588; D353,692; D431,328; 5,208,688; 5,248,880; 5,252,817; 5,347,383; 5,377,032; 5,515,186; 5,519,522; 5,533,206; 5,751,258; 5,959,705; 6,067,129; 6,070,264; 6,151,711; 6,260,197; 6,341,382; and related foreign patents. Jackson Safety floor signs are covered by US patent D.395,334 and Canadian design registration No.83761. Other US and foreign patents pending. For additional patent numbers, contact Jackson Safety.

WARNING

Read this section completely before selecting your Jackson Safety products. Our products are tested to meet the standards of the American National Standards Institute (ANSI) and other applicable standards. All warning statements, operating instructions and industry standards should be complied with at all times. Please read any and all warning statements attached to or associated with any Jackson Safety product prior to use. Failure to use only Jackson Safety designed, produced and tested components, attachments and replacement parts can adversely affect product performance resulting in serious injury. Installing generic parts or components voids all standards compliances, all guarantees and warranties and makes the installer solely liable for the consequences.

TABLE OF CONTENTS



PERSONAL PROTECTION EQUIPMENT

| | |
|--------------------|----|
| Safety Eyewear | 6 |
| Safety Goggles | 16 |
| Face Protection | 20 |
| Head Protection | 24 |
| Hearing Protection | 32 |
| Seasonal | 40 |
| First Aid | 45 |
| Respiratory | 46 |

WELDING

| | |
|--------------------|----|
| Welding Safety | 48 |
| Electric Line | 70 |
| Contour | 74 |
| Welding Curtains | 82 |
| Roll Goods | 86 |
| Stur-D-Screens | 88 |
| Welding Blankets | 92 |
| Strip Curtains | 94 |
| Track Hardware | 96 |
| Specialty Products | 97 |

TRAFFIC SAFETY

| | |
|-------------------|-----|
| Safety Apparel | 102 |
| Traffic Cones | 110 |
| Delineators | 115 |
| Drums | 116 |
| Barricades | 117 |
| Roll-Up Signs | 120 |
| Sign Stands | 123 |
| Stop/Slow Paddles | 126 |
| Flags | 127 |
| Motor Safety | 128 |
| Fencing | 132 |
| Floor Warning | 134 |

personalsafety

PERSONAL PROTECTION EQUIPMENT THAT YOU CAN TRUST

The Jackson Safety® name has continuously been identified with quality personal protective equipment that provides safety and comfort to workers in a wide variety of industries. Whether the need is for eye and face protection in food processing applications, head protection on a construction job site, or hearing protection at an airport, Jackson Safety® provides the widest range of safety choices for every worker.

With respected market-leading brand names as Smith & Wesson® in eyewear and the pioneering Monogoggle brand of safety goggles, Jackson Safety® is on the job in terms of product innovation, striving to always provide safety product style and comfort for both work and leisure situations. The trend-setting style of our Nemesis family of safety eyewear exemplifies the approach of styles that cross a broad range of applications.

Customization is a key element in today's personal protective equipment, and Jackson Safety® is proud to offer custom identification with logos and designs on a wide variety of products, ranging from hardhats to safety glasses to hearing protectors. We want your identity to be known, as well as your market brand.

Pulling together all of your safety needs into one integrated system has become the trademark of Jackson Safety products, best illustrated in our ATS (Above The Shoulder) safety systems that combine the best in head, hearing, and face protection in a single unit. Add our new line of respiratory products, and workers have complete flexibility and confidence in any industrial application.

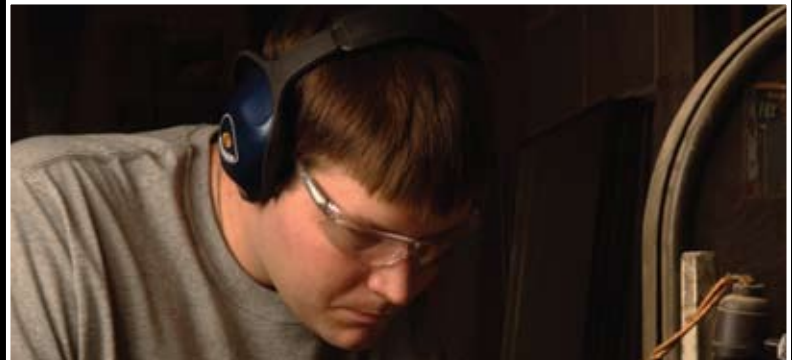

STANDARDS

ANSI Z87.1+: The American National Standards Institute (ANSI) set forth requirements for the design, construction, testing, and use of eye protection devices, including standards for impact and penetration resistance. Requirements include, but are not limited to, durability, easy to clean, reasonably comfortable, secure fit, fit over, or incorporate, prescription eyewear and, most importantly, provide adequate protection against the hazards for which they are designed.

ANSI Z89.1: The American National Standards Institute (ANSI) provides performance and testing requirements for hard hats. This specification includes requirements for protection from lateral impact or top-only impact, giving employers and users the flexibility to specify the helmet that best meets the needs of their specific workplace. Type I hard hats provide top protection and Type II hard hats provide lateral impact protection. The three classes indicate the helmets electrical insulation rating: Class E (electrical), Class G (general) and Class C (conductive).

NRR: Noise Reduction Rating (NRR) is the measure, in decibels, of how well a hearing protection reduces noise, as specified by the Environmental Protection Agency (EPA). The higher the number, the greater the noise reduction.

NIOSH: The National Institute for Occupational Safety and Health is the US federal agency responsible for conducting research and making recommendations for the prevention of work-related injury and illness. NIOSH issues recommendations for respirator use. Industrial type approvals are in accordance to the NIOSH federal respirator regulations 42 CFR Part 84.

OSHA: Occupational Safety and Health Administration (OSHA) is an agency of the United States Department of Labor. Their mission is to prevent work-related injuries, illnesses and deaths by issuing and enforcing standards for workplace safety and health.

ISEA: The International Safety Equipment Association is the trade association in the United States for companies that manufacture safety and personal protective equipment. Its member companies are world leaders in the design and manufacture of protective clothing and equipment used in factories, construction sites, hospitals and clinics, farms, schools, laboratories, emergency response and in the home.



BASE CURVE

Base curve is the measurement of an eyewear lens or curvature. The higher the base curve, the greater the sweep of the eyewear. A higher base curve provides more wrap-around protection, peripheral vision and can reduce the need for side shields.

MARKINGS – ANSI, CSA, CE

ANSI: The American National Standards Institute (ANSI) is a private, non-profit organization that administers and coordinates the US voluntary standardization and conformity assessment system.

CSA: The Canadian Standards Association is a not-for-profit membership-based association serving business, industry, government and consumers in Canada and the global marketplace. CSA develops standards that address real needs, such as enhancing public safety and health.

CE: A mandatory European product marking and certification system that indicates the product complies with all applicable European product safety, health and environmental requirements within the CE marking system.

ANTI-FOG LENS COATING

We've subjected our lenses to extensive testing. We froze them. Heated them. Soaked them. Cleaned them. We put them through humidity and anti-static tests. No matter what we tried, our anti-fog lenses wouldn't fog up. In fact, these tests, combined with on-the-job field evaluations, indicate that our anti-fog coating will eliminate lens fogging in 99% of workplace applications.



LENS OPTIONS

JACKSON SAFETY'S EYEWEAR LENSES ARE MADE OF A POLYCARBONATE MATERIAL THAT PROVIDE 99.9% UV PROTECTION.















LENS COATINGS:

- Polarized Lens: Protection from glare reduces eye fatigue
- Hard Coat: For scratch resistant
- Anti-fog for humid environments and extreme temperature variances
- Uncoated: for economical budgets
- Visiclear™ : Prevents flash fogging

STANDARD LENS TINTS:

-  Clear Lens: Allows maximum visible light transmission, this safety lens is used for indoor applications where impact protection is required.
-  Smoke Lens: Worn on bright, sunny days, these lenses provide maximum glare reduction and are ideal when eye strain is a major factor.
-  Amber/Yellow Lens: Light gathering properties make this lens ideal for low light environments in which contrast is low.

SPECIALTY LENS TINTS:

-  Blue Shield and Copper Blue Block: Filters out blue light for enhanced contrast and is ideal for medium to bright outdoor conditions.
-  IRUV 3.0 Lens: Protects against infrared (IRUV) and ultraviolet radiation. Perfect for light cutting and brazing applications.
-  IRUV 5.0 Lens: Protects against infrared (IRUV) and ultraviolet radiation. Perfect for medium to heavy cutting and brazing applications.
-  Smoke Mirror Lens: Smoke tint sunglass with outer mirror finish coating, for outdoor use where sunlight can cause eyestrain and fatigue.
-  Silver Mirror Lens: Smoke tint sunglass with outer silver finish coating, for outdoor use where sunlight can cause eyestrain and fatigue.
-  Gold Mirror Lens: Smoke tint sunglass with outer gold mirror finish coating, for outdoor use where sunlight can cause eyestrain and fatigue.
-  Blue Mirror and Metallic Blue Lens: Smoke tint sunglass with outer blue mirror finish coating, for outdoor use where sunlight can cause eyestrain.
-  Red Mirror Lens: Smoke tint sunglass with outer red mirror finish coating, for outdoor use where sunlight can cause eyestrain and fatigue.
-  Metallic Rainbow Lens: Smoke tint sunglass with outer rainbow mirror finish coating, for outdoor use where sunlight can cause eyestrain.
-  Bronze Lens: Superior visual definition with increased contrast and enhanced contours in most light conditions.
-  Copper and Brown Lens: Effective at filtering light in hazy, foggy, or low light conditions by enhancing contrast.
-  Orange Lens: Filters out blue and green light to reduce eye fatigue, improves visual acuity during curing and inspection processes.
-  Indoor/Outdoor Lens: Comfortable solution for moving from indoor or shaded locations to direct sunlight and back.
-  Teal Lens: Commonly used for indoor applications where there is an excessive amount of yellow or sodium vapor light, offers a high level of contrast. This lens is not recommended for driving situations.
-  Light Blue Lens: Commonly used in indoor or low light outdoor applications for enhanced contrast.

Actual lens colors may vary according to each style

Shown in image
 #3016308 - Equalizer, Smoke Lens
 #3013362 - Charger, White



NEW

EQUALIZER™

BASE CURVE
8



Smith & Wesson®

Stylized frame features a cutting edge design that is ideal for work and play. Sport grip temples help to eliminate slippage and anti-scratch, dual lenses offer wrap-around protection. Every glass comes with a Smith & Wesson® micro-fiber carry pouch that doubles as a cleaning cloth. Standard Pack: 12

FRAME/LENS

GUNMETAL/CLEAR
 GUNMETAL/CLEAR ANTI-FOG
 GUNMETAL/SMOKE ANTI-FOG
 GUNMETAL/IN/OUTDOOR
 RED/AMBER
 BLUE/BLUE MIRROR

PART#

3016306
 3016307
 3016308
 3016309
 3016310
 3016311



Shown above
 #3016308 - Smoke Lens



Shown above
 #3016311 - Blue Mirror Lens

NEW

ELITE™

BASE CURVE
8



Smith & Wesson®

Lightweight “retro-style” design provides the latest fashion statement in eyewear. Wide temple provides structural integrity and stability and an anti-scratch, dual lenses offers wrap-around protection. Every glass comes with a Smith & Wesson® micro-fiber carry pouch that doubles as a cleaning cloth. Standard Pack: 12

FRAME/LENS

BLACK/CLEAR ANTI-FOG
 BLACK/SMOKE ANTI-FOG
 BLACK/IN/OUTDOOR
 BLACK/AMBER ANTI-FOG
 BLACK/BLUE MIRROR

PART#

3016312
 3016313
 3016315
 3016314
 3016316

**Smith & Wesson®****MAGNUM 3G™**BASE CURVE
7

Classic Smith & Wesson® Magnum style with hinge stops to help prevent scratches. Ergonomic self-adjusting nose pads with rubber fingers for ultimate comfort. Available in reduced sizes for small faces. Standard Pack: 12

| FRAME/LENS | PART# |
|--------------------------|---------|
| BLACK/CLEAR | 3011672 |
| BLACK/CLEAR ANTI-FOG | 3011670 |
| BLACK/SMOKE | 3011674 |
| BLACK/SMOKE ANTI-FOG | 3011840 |
| GRAY/IN/OUTDOOR ANTI-FOG | 3011681 |
| BLACK/YELLOW | 3011676 |
| BLACK/IRUV 3.0 | 3011668 |
| BLACK/IRUV 5.0 | 3011669 |
| BLACK/COPPER BLUE BLOCK | 3011671 |
| PLATINUM/ORANGE | 3011678 |
| PLATINUM/TEAL | 3011679 |
| BLACK/GOLD MIRROR | 3011824 |
| PLATINUM/CLEAR | 3011841 |

MAGNUM MINI

| FRAME/LENS | PART# |
|---------------------------|---------|
| BLACK/CLEAR | 3011673 |
| BLACK/SMOKE | 3011675 |
| BLACK/IN/OUTDOOR ANTI-FOG | 3013027 |
| BLACK/MIRROR | 3013025 |
| BLACK/YELLOW | 3011677 |

**Smith & Wesson®****38 SPECIAL™**BASE CURVE
8

Legendary frame design. Ergonomically designed temples with rubber insert temple tips for a soft, snug, and secure fit. Standard Pack: 12

| FRAME/LENS | PART# |
|------------------------------|----------|
| BLACK/CLEAR | 3011699* |
| BLACK/SMOKE | 3011703* |
| METALLIC GRAY/GRADIENT SMOKE | 3011701* |
| CHROME/BLUE MIRROR | 3011698* |
| BLACK/RED MIRROR | 3011702* |

**Smith & Wesson®****VIEWMASTER™**BASE CURVE
8

Polarized safety lenses offer protection from reflected glare and helps to reduce eye fatigue. Ergonomically designed temples with rubber insert temple tips for a soft, snug, and secure fit. Every glass comes with a micro-fiber carry pouch that doubles as a cleaning cloth. Standard Pack: 12

| FRAME/LENS | PART# |
|------------------------------|---------|
| METALLIC GRAY/POLARIZED GRAY | 3011704 |

safetyeyewear





Smith & Wesson®



CODE 4™

BASE CURVE
7



Sporty, lightweight design weighs less than one ounce! Scratch resistant polycarbonate lenses. Ribbed, non-slip rubber nose cushion. Contoured temple tips for precise fit. Hinge stops help to prevent lens damage. Standard Pack: 12

| FRAME/LENS | PART# |
|-------------------------|---------|
| BLACK/CLEAR | 3011687 |
| BLACK/SMOKE | 3011690 |
| BLACK/MIRROR | 3011688 |
| BLACK/COPPER BLUE BLOCK | 3011685 |
| PLATINUM/ORANGE | 3011689 |



Smith & Wesson®

PHANTOM™

BASE CURVE
7



Futuristic and frameless, lightweight design provides a comfortable fit. Precision cut-to-shape spherical lens for increased peripheral and distortion free protection. Straight back bayonet design temples eliminate temple pressure. Standard Pack: 12

| FRAME/LENS | PART# |
|-----------------------|---------|
| PEWTER/CLEAR | 3011694 |
| PEWTER/CLEAR ANTI-FOG | 3011693 |
| BLACK/SMOKE | 3011696 |
| CHROME/SILVER MIRROR | 3011697 |
| COPPER/ORANGE | 3011695 |

"Phantom is a registered trademark of Sellstrom Manufacturing Company"



Smith & Wesson®

SIGMA™

BASE CURVE
8



Contemporary, combination of gun metal finish frame and stylish chrome temples. Soft foam pad along brow provides a snug and comfortable fit. Lightweight, stylish design offers protection and safety. Every glass comes with a micro-fiber carry pouch that doubles as a cleaning cloth. Standard Pack: 12

| FRAME/LENS | PART# |
|----------------------|---------|
| GUN METAL/CLEAR | 3013122 |
| GUN METAL/SMOKE | 3013124 |
| GUN METAL/IN/OUTDOOR | 3013125 |
| GUN METAL/YELLOW | 3013123 |



Smith & Wesson®

10X™

BASE CURVE
10



Ergonomic metal finished frame with brow bar for stability and style. Self-adjusting silicone nose pad and rubber coated temple tips. Hinge stops help to prevent lens scratches. Standard Pack: 12

| FRAME/LENS | PART# |
|-------------------------|---------|
| MATTE CHROME/CLEAR | 3012787 |
| BRONZE/SMOKE | 3012789 |
| BLACK/YELLOW | 3012790 |
| MATTE CHROME/RED MIRROR | 3012788 |

safety eyewear

NEMESIS™

BASE CURVE
8



Sleek, sporty, lightweight design with soft touch temples for added comfort. Single lens wrap-around protection. Every glass includes a neck cord. Available in reader style lenses (see page 12). Standard Pack: 12

| FRAME/LENS | PART# |
|----------------------|------------------|
| BLACK/CLEAR | 3000354* [19804] |
| BLACK/CLEAR ANTI-FOG | 3000355* [19805] |
| BLACK/SMOKE | 3000356* [19806] |
| BLACK/IN/OUTDOOR | 3000357* [19807] |
| BLACK/BLUE MIRROR | 3000358* [19808] |
| BLACK/AMBER | 3000359* [19809] |
| BLUE/LIGHT BLUE | 3011373* [19859] |
| BLACK/BLUESHIELD | 3011374* [19860] |
| CAMO/BRONZE | 3011375* |
| BLACK/IRUV 3.0 | 3004762* |
| BLACK/IRUV 5.0 | 3004761* |

NEMESIS VL™

BASE CURVE
8



Frameless ultra-lightweight, **33% lighter than Nemesis**. No-brow design increases upward and peripheral vision. Slip-stop temples. Compact profile accommodates smaller faces. Every glass includes a neck cord. Standard Pack: 12

| FRAME/LENS | PART# |
|--------------------------|----------|
| GUN METAL/CLEAR | 3013536* |
| GUN METAL/CLEAR ANTI-FOG | 3013537* |
| GUN METAL/SMOKE | 3013538* |
| GUN METAL/IN/OUTDOOR | 3013539* |
| GUN METAL/BLUE MIRROR | 3013540* |
| CAMO/BRONZE | 3013542 |
| GUN METAL/IRUV 5.0 | 3013544 |

NEMESIS™ CSA

BASE CURVE
8



Sleek, sporty lightweight design with soft touch temples. Large, single lens wrap-around protection for added protection. Every glass includes a neck cord. Meets CSA standards. Standard Pack: 12

| FRAME/LENS | PART# |
|----------------------------|-----------|
| MEETS CSA STANDARDS | |
| BLACK/CLEAR | 3013296** |
| BLACK/SMOKE MIRROR | 3013298** |
| BLACK/IN/OUTDOOR | 3013299** |
| BLACK/IRUV 5.0 | 3014556** |
| Z94.3 COMPLIANT | |
| BLACK/CLEAR ANTI-FOG | 3013297* |
| BLACK/BLUE MIRROR | 3013300* |
| BLUE/LIGHT BLUE | 3013301* |
| BLACK/BLUESHIELD | 3013302* |
| GUN METAL/SMOKE | 3013303* |
| CAMO/BRONZE | 3013304* |
| BLACK/IRUV 3.0 | 3014555* |

ENVISION™

BASE CURVE
9



Adjustable temples create a custom fit with wrap-around protection. Soft grip comfort temples. Meets CSA standards. Standard Pack: 12

| FRAME/LENS | PART# |
|----------------------|-------------------|
| BLACK/CLEAR | 3000337** [19741] |
| BLACK/CLEAR ANTI-FOG | 3000338** [19742] |
| BLACK/SMOKE | 3000339** [19743] |
| BLACK/IN/OUTDOOR | 3000341** [19745] |



HELLRAISER™

BASE CURVE
8



Streamlined, sunglass styling with *extreme* lightweight design. High performance polycarbonate lens for added protection. Flex point temples for comfort and stability. Standard Pack: 12

| FRAME/LENS | PART# |
|----------------------|----------|
| BLACK/CLEAR | 3013851* |
| BLACK/CLEAR ANTI-FOG | 3013853* |
| BLACK/SMOKE ANTI-FOG | 3013854* |
| BLACK/IN/OUTDOOR | 3013856* |
| BLACK/AMBER | 3013855* |
| BLACK/LIGHT BLUE | 3013857* |
| BLACK/BLUE MIRROR | 3013858* |
| BLACK/IRUV 3.0 | 3013859* |
| BLACK/IRUV 5.0 | 3013860 |

NOMADS™

BASE CURVE
8



Stylish and lightweight with detachable side shields. Highly mirrored lenses are ideal for different light conditions. Standard Pack: 12

| FRAME/LENS | PART# |
|------------------------|---------------------|
| BLACK/CLEAR | 3003291 [1439-0000] |
| BLACK/SMOKE | 3003292 [1439-0001] |
| BLACK/SILVER MIRROR | 3003293 [1439-0002] |
| BLACK/METALLIC RAINBOW | 3003294 [1439-0003] |
| BLACK/METALLIC BLUE | 3003295 [1439-0004] |

VISIO™

BASE CURVE
8



One-piece polycarbonate lens with adjustable temples and wrap-around protection. Unique duo-tone frame, lightweight design and comfortable fit. Standard Pack: 12

| FRAME/LENS | PART# |
|-----------------------------|-----------------|
| SILVER/CLEAR | 3000303 [19492] |
| SILVER/CLEAR ANTI-FOG | 3000304 [19493] |
| SILVER/SMOKE | 3000305 [19494] |
| SILVER-BLACK/SMOKE ANTI-FOG | 3000306 [19495] |
| BLACK/IN/OUTDOOR | 3000309 [19498] |
| BLACK/AMBER | 3000307 [19496] |
| BLACK/BLUE MIRROR | 3000308 [19497] |

ELEMENT™

BASE CURVE
9.5



Lightweight popular styling with an economical price. Universal nose bridge for comfort. Also available in reader lenses (see page 12). Standard Pack: 12

| FRAME/LENS | PART# |
|-------------------|------------------|
| BLACK/CLEAR | 3004880* [31005] |
| BLACK/SMOKE | 3004882* [31006] |
| BLACK/IN/OUTDOOR | 3011379* |
| BLACK/AMBER | 3004883* [31007] |
| BLACK/BLUE MIRROR | 3011380* |

NEMESIS RX™



'Cheaters' style with integral diopters for vision assistance. Larger lens for a more complete wrap-around impact protection. Enhanced nose piece design to channel away sweat. Every glass includes a neck cord. Z94.3 compliant. Standard Pack: 6

| FRAME/LENS | PART# |
|------------------|-----------|
| BLACK/CLEAR +1.0 | 3013305** |
| BLACK/CLEAR +1.5 | 3013306** |
| BLACK/CLEAR +2.0 | 3013307** |
| BLACK/CLEAR +2.5 | 3013308** |
| BLACK/CLEAR +3.0 | 3013309** |

30-06™ READERS



Stylish, ergonomic, nylon frame combined with high performance polycarbonate lenses for ultimate protection. Soft, comfortable self-adjusting rubber nose pad. Precise placement of lens inserts helps prevent accidents, headaches and eyestrain. Standard Pack: 6

| FRAME/LENS | PART# | FRAME/LENS | PART# |
|------------------|---------|---------------------|---------|
| TORT/BROWN +1.5 | 3011712 | BLACK/YELLOW +1.5 | 3011724 |
| TORT/BROWN +2.0 | 3011713 | BLACK/YELLOW +2.0 | 3011725 |
| TORT/BROWN +2.5 | 3011714 | BLACK/YELLOW+2.5 | 3011726 |
| BLACK/CLEAR +1.0 | 3011716 | BLACK/IRUV 5.0 +1.5 | 3013933 |
| BLACK/CLEAR +1.5 | 3011717 | BLACK/IRUV 5.0 +2.0 | 3013968 |
| BLACK/CLEAR +2.0 | 3011718 | BLACK/IRUV 5.0 +2.5 | 3013969 |
| BLACK/CLEAR +2.5 | 3011719 | | |
| BLACK/CLEAR +3.0 | 3011720 | | |

DUAL SEGMENT READERS



Perfect for individuals who work overhead or upside down and need to look up for near vision as well as down. Helps prevent neck and eye strain, as well as headaches. Standard Pack: 12

| FRAME/LENS | PART# |
|------------------|---------|
| BLACK/CLEAR +1.5 | 3013327 |
| BLACK/CLEAR +2.0 | 3013328 |
| BLACK/CLEAR +2.5 | 3013329 |

ELEMENT RX™



Economical 'cheaters' style safety glass with lightweight, popular design. Universal nose bridge for comfort. Standard Pack: 12

| FRAME/LENS | PART# |
|------------------|---------|
| BLACK/CLEAR +1.0 | 3014253 |
| BLACK/CLEAR +1.5 | 3014254 |
| BLACK/CLEAR +2.0 | 3014255 |
| BLACK/CLEAR +2.5 | 3014256 |
| BLACK/CLEAR +3.0 | 3014257 |



NEW



OTG™

BASE CURVE
4



Streamlined, stylish and comfortable. The new standard in over-the-glass safety eyewear. Fits over most prescription eyewear. Integral side shields provide added protection. Z94.3 compliant. Standard Pack: 12

| FRAME/LENS | PART# |
|-----------------------------|----------|
| BLACK/CLEAR ANTI-FOG | 3015022* |
| BLACK/SMOKE MIRROR ANTI-FOG | 3015023* |
| BLACK/IN/OUTDOOR | 3015024* |
| BLACK/IRUV 5.0 | 3018175 |

UNISPEC™

BASE CURVE
4



Low cost wrap-around protection with one-piece polycarbonate lens and uncoated frame. Fits over most prescription eyewear. Side shields provide added protection. Standard Pack: 12

| FRAME/LENS | PART# |
|-------------------|------------------|
| CLEAR UNCOATED | 3000285* [18832] |
| CLEAR HARD COATED | 3005206 [18333] |
| IRUV 3.0 | 3000323 [19630] |
| IRUV 5.0 | 3000324 [19631] |

CUDAS™

BASE CURVE
6



Lens curve provides for peripheral vision and protection. Durable, modified nylon frame with Cudaslide adjustable temples for an individual fit with 5 different lengths. Standard Pack: 12

| FRAME/LENS | PART# |
|----------------------|-----------------|
| BLACK/CLEAR | 3000287 [19142] |
| BLACK/CLEAR ANTI-FOG | 3000288 [19143] |
| BLACK/SMOKE | 3000289 [19144] |
| BLACK/SMOKE ANTI-FOG | 3000290 [19145] |
| BLACK/AMBER | 3000293 [19149] |

safety eyewear

DIOPTR SELECTION CHART

| | |
|--|------|
| If this line is difficult to read, use power | +1.0 |
| If this line is difficult to read, use power | +1.5 |
| If this line is difficult to read, use power | +2.0 |
| If this line is difficult to read, use power | +2.5 |
| If this line is difficult to read, use power | +3.0 |

EYEWEAR DISPLAYS

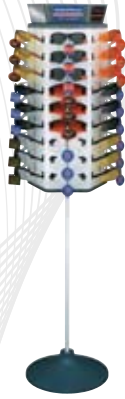

S&W® 54 PAIR FLOOR DISPLAY

Smith & Wesson® revolving floor stand
Capacity: 54 pair of glasses
Dimensions: 71" Height, 18" Diameter

| DESCRIPTION | PART# |
|-----------------|---------|
| 54 PAIR SPINNER | 3011828 |



S&W® COUNTER DISPLAYS

Smith & Wesson® revolving counter stand
Capacity: 24 or 36 pair of glasses
Dimensions: (24) 22" Height, 13" Diameter
(36) 32" Height, 14" Diameter

| DESCRIPTION | PART# |
|-----------------|---------|
| 24 PAIR SPINNER | 3012156 |
| 36 PAIR SPINNER | 3011827 |



6 PAIR STACKING DISPLAY

Stationary 6 pair stacking display. Some assembly required.
Capacity: 6 pair of glasses
Dimensions: 22" Height, 5" Diameter

| DESCRIPTION | PART# |
|------------------------|---------|
| 6 PAIR EYEWEAR DISPLAY | 3014039 |



LOCKING DISPLAYS

Locking, rotating counter display eliminates theft.
Capacity: 18 or 24 pair of glasses
Dimensions: (18) 17" Height, 11.5" Diameter
(24) 17" Height, 12" Diameter

| DESCRIPTION | PART# |
|-------------------------|---------|
| 18 PAIR LOCKING SPINNER | 3014038 |
| 24 PAIR LOCKING DISPLAY | 3014037 |

safetyeyewear

LENS CLEANING



Sturdy, corrugate construction with easy wall mount design. For glass, plastic and polycarbonate lenses, goggles and faceshields. Anti-fog, anti-static formula. Towelettes are available in 100 individually packaged (per box). Cleaning station includes spray bottle with 100 low lint tissues.

| DESCRIPTION | PART# |
|------------------------------|---------|
| LENS CLEANING TOWELETES | 3000555 |
| DELUXE LENS CLEANING STATION | 3000554 |



EYEWEAR NECK CORDS



Eyewear not included



Eyewear not included

EYEWEAR CORDS

Conveniently fits any eyewear. Standard Pack: 12/bag

| DESCRIPTION | PART# |
|---------------------|---------|
| BLACK EYEWEAR CORDS | 3000283 |

CHUMS® ORIGINAL

Fits standard frames, adjustable fit. Available in small and large. Standard Pack: 25/bag

| DESCRIPTION | PART# |
|-------------------------|---------|
| ASSORTED COLORS, CHUMS® | 3005243 |
| BLACK, CHUMS® | 3005244 |

EYEWEAR CUSTOMIZATION PROGRAM



CUSTOM EYEWEAR DECORATING DIMENSIONS

| FRAME STYLE | FRAME SIDE - DIMENSIONS | LENS DIMENSIONS |
|-------------------|-------------------------------|--------------------------|
| S&W® EQUALIZER™ | RIGHT - 1"W x 1/8"H | NOT AVAILABLE |
| S&W® ELITE™ | RIGHT - 1"W x 1/4"H | NOT AVAILABLE |
| S&W® MAGNUM™ MINI | RIGHT - 5/16" W x 3/8" H | 3/4" W x 3/8" H |
| S&W® VIEWMASTER™ | RIGHT - 3/4"W x 3/8"H | NOT AVAILABLE |
| S&W® 38 SPECIAL™ | RIGHT - 7/8" W x 1/8" H | 3/4" W x 3/8" H |
| S&W® PHANTOM™ | NOT AVAILABLE | RIGHT ONLY - 1"W x 1/4"H |
| S&W® CODE 4™ | RIGHT - 7/8" W x 1/8" H | 3/4" W x 3/8" H |
| NEMESIS™ | LEFT - 3/4" W x 1/8" H | 3/4" W x 3/8" H |
| NEMESIS™ VL | LEFT-3/4"W x 3/16"H | 3/4" W x 3/8" H |
| ENVISION™ | RIGHT - 1/2" W x 1/4" H | NOT AVAILABLE |
| HELLRAISER™ | RIGHT - 1/2"W x 3/16"H | NOT AVAILABLE |
| VISIO™ | RIGHT & LEFT - 3/4"W x 1/8" H | 1/2" W x 1/2"H |
| ELEMENT™ | RIGHT - 1/2" W x 1/4" H | 3/4" W x 3/8" H |
| 30-06™ | LEFT-3/4"W x 3/16"H | 3/4" W x 3/8" H |
| CUDAS™ | RIGHT - 5/8"W x 1/8"H | 1/2" W x 1/2"H |
| OTG™ | LEFT - 7/8"W x 1/4"H | NOT AVAILABLE |

DECORATING ON LEFT OR RIGHT ONLY

- Minimum Order 72 safety eyewear
- In order to provide superior screening, we require camera ready artwork (black on glossy white or film positive with sharp images) and color separated
- A charge may be invoiced for artwork that requires redrawing or typesetting and may add 10-15 business days to lead time
- Delivery of pad printed eyewear will take approximately 5-7 business days upon receipt of distributor approval of final artwork
- A cliché charge reflects the cost of creating the custom cliché'. Cliché' remains the property of Jackson Safety®
- For more information, call customer service at 800-428-8185 or email us info@jacksonsafety.com
- ONLY EYEWEAR MENTIONED ARE AVAILABLE FOR DECORATING

MONOGOGGLE® HISTORY

The history of our protective safety goggles began over 30 years ago with an anti-fog model designed to protect against chemical splash. This model went on to become the staple of millions of safety programs throughout the industry, and is now synonymous with on-the-job eye protection. You can be confident about the protection that Jackson Safety® goggles provide. Today our line still meets ANSI Z87.1-2003 performance criteria. Jackson Safety's unique Visiclear™ coating has been scientifically formulated after a series of on-the-job evaluations eliminating lens fogging in 99% of workplace applications.

All lenses are made with an optical grade polycarbonate material and provide 99.9% UV protection.

MONOGOGGLE® 201

DUST & IMPACT GOGGLE



Frame provides impact protection and direct ventilation where chemical splashes and fumes are not primary hazards. Separate, pliable plastic nosepiece for a comfortable seal. .060" polycarbonate lens. Standard Pack: 36

| FRAME/LENS | PART # |
|-------------|-------------------|
| GREEN/CLEAR | 3005051** [10013] |

MONOGOGGLE® 202

DUST & IMPACT GOGGLE



Unventilated design provides protection against fumes, dust, and chemical splashes. Lightweight two-piece frame with separate nosepiece for better fit and comfort. Can be worn over most prescription eyeglasses. .066" polycarbonate lens. Standard Pack: 36

| FRAME/LENS | PART # |
|------------------------|-----------------|
| GREEN/CLEAR | 3005052 [10024] |
| GREEN/CLEAR VISICLEAR™ | 3005055 [10097] |

MONOGOGGLE® 211

CHEMICAL SPLASH GOGGLE



Patented indirect ventilation system provides increased air flow, minimizes condensation and fogging, and protects against chemical splash. Soft frame design with pantoscopic angle to improve work area visibility and assist bifocal wearers. Soft, pliable plastic nosepiece for a snug, comfortable seal. .066" polycarbonate lens. Standard Pack: 36

| FRAME/LENS | PART # |
|-------------------------|--------------------|
| GREEN/CLEAR | 3000005*** [10032] |
| GREEN/CLEAR VISICLEAR™ | 3000013*** [10115] |
| COMFORT FOAM/VISICLEAR™ | 3005056** [10116] |
| SMOKE/CLEAR VISICLEAR™ | 3005058 [10148] |

MONOGOGGLE® VPC

CHEMICAL SPLASH GOGGLE



Indirect ventilation ideal for chemical splash protection. Fits over most prescription eyewear. Pantoscopic design assists bifocal wearers and improves work area visibility. Soft, pliable nosepiece. Headband buckle located towards rear of goggle, so that it will not interfere with peripheral vision. .060" polycarbonate lens. Standard Pack: 36

| FRAME/LENS | PART # |
|-----------------------|-------------------|
| GRAY/CLEAR VISICLEAR™ | 3003414** [10195] |

safetygoggles



MONOGOGGLE® XTR™

CHEMICAL SPLASH GOGGLE



Extreme visual clarity in all conditions! This lightweight, stylish goggle protects against chemical splashes, while providing increased visibility due to its cylindrical lens. A soft pliable frame conforms to the face for comfort and is easy to clean and sanitize. Goggle only weighs 9.2 ounces! 5.0 model features flame retardant headband. .060" polycarbonate lens.
Standard Pack: 6

| FRAME/LENS | PART # |
|-------------------------|---------|
| BLUE/CLEAR ANTI-FOG | 3010334 |
| BLUE/SMOKE ANTI-FOG | 3010335 |
| BLACK/IRUV 5.0 ANTI-FOG | 3010338 |

THE SHIELD™

CHEMICAL SPLASH GOGGLE



Features the Monogoggle XTR™ with a polycarbonate shield for full face protection. Shield detaches from the goggle. Curved faceshield conforms to shape of face offering better protection. 5.0 model features flame retardant headband. The Shield only weighs 14.1 ounces! Standard Pack: 6

| FRAME/LENS | PART # |
|-----------------------|---------|
| BLUE/CLEAR VISICLEAR™ | 3010343 |
| BLACK/IRUV 3.0 AF | 3010345 |
| BLACK/IRUV 5.0 AF | 3010346 |

MONOSHIELD™

CHEMICAL SPLASH GOGGLE



Distortion-free vision because it attaches to the MonoGoggle® 211 with PVC gaskets. Can be worn with caps and disposable respirators. Clear see-through material allows for easy wearer identification. Polycarbonate shield provides face protection.
Standard Pack: 12

| FRAME/LENS | PART # |
|-------------|-----------------|
| GREEN/CLEAR | 3005059 [10179] |

RESPIRATOR FIT

CHEMICAL SPLASH GOGGLE



Indirect ventilation with wider nosepiece fits over most half mask respirators. Internal baffles maximize splash protection. Trusted Monogoggle® design. .060" polycarbonate lens.
Standard Pack: 36

| FRAME/LENS | PART# |
|------------------------|-----------------|
| GREEN/CLEAR VISICLEAR™ | 3005057 [10140] |

REVOLUTION™

CHEMICAL SPLASH GOGGLE



Cross Vent™ technology keeps air flowing in and moisture out. VisiClear™ anti-fog, anti-scratch, anti-static lens coating. Accommodates large Rx insert (sold separately). Expanded visual field. .080" polycarbonate lens provides impact protection. Standard Pack 30

| FRAME/LENS | PART # |
|-------------------------------|-----------------|
| BLUE/CLEAR VISICLEAR™ | 3000048 [10500] |
| BLUE/SMOKE VISICLEAR™ | 3000049 [10501] |
| BLUE/AMBER VISICLEAR™ | 3000050 [10501] |
| BLACK/CLEAR VISICLEAR™ | 3009654 [10541] |
| BLACK/SMOKE VISICLEAR™ | 3005121 [10542] |
| REVOLUTION RX INSERT (25/BAG) | 3000052 [10505] |



WILDCAT™

EXTREME PERFORMANCE VISION PROTECTION



Features extreme heat resistance - will not melt, drip, or ignite at 350°F for five minutes. Adjustable side vents to ensure increased air flow. Fits naturally to the contour of your face in order to block out airborne contaminants. Lightweight and comfortable with a pivot headband that allows for optimal placement. Meets NFPA 1977 standards and is Z94.3 compliant. Standard Pack: 12



| LENS | PART # |
|-------------------|----------|
| CLEAR ANTI-FOG | 3013710* |
| SMOKE ANTI-FOG | 3013711* |
| AMBER ANTI-FOG | 3013712* |
| IRUV 3.0 ANTI-FOG | 3013713* |
| IRUV 5.0 ANTI-FOG | 3013714* |

SG30

DUST & IMPACT GOGGLE



Economical dust and impact protection with .060 polycarbonate lens and direct ventilation. .060" polycarbonate lens.

| FRAME/LENS | PART # |
|-----------------------|------------------|
| GREEN/CLEAR, 200 PACK | 3005067* [10260] |
| GREEN/CLEAR, 50 PACK | 3009541 [10468] |

SG34

CHEMICAL SPLASH GOGGLE



Economical chemical splash protection with .060 polycarbonate lens and button vents that provide indirect venting. .060" polycarbonate lens.

| FRAME/LENS | PART # |
|-----------------------|------------------|
| GREEN/CLEAR, 200 PACK | 3005066 [10258] |
| GREEN/CLEAR, 50 PACK | 3003415* [10257] |



MRXV™

CHEMICAL SPLASH GOGGLE



Spherical lens provides more than 360 degrees of vision. .090 polycarbonate lens has indirect vents that offer splash protection. .090" polycarbonate lens. Standard Pack: 36

| FRAME/LENS | PART # | |
|------------------------|---------|---------|
| BLUE/CLEAR VISICLEAR™ | 3005068 | [10276] |
| BLUE/CLEAR FOGGARD® | 3005069 | [10277] |
| SMOKE/CLEAR VISICLEAR™ | 3005070 | [10280] |
| SMOKE/CLEAR FOGGARD® | 3005071 | [10281] |

GOGGLE TOGGLE™



Snaps into universal hard hat slots on most safety caps. Ideal for storage of goggles in front of cap and back of cap. Perfect for when goggles are worn occasionally or only in certain applications, but must be kept with workers at all times.



| DESCRIPTION | PART # | |
|------------------------|---------|---------|
| GOGGLE TOGGLE, 50 PACK | 3005127 | [14420] |

GOGGLE RETAINER



Ideal for use with non-slotted hard hats. Goggle Retainer holds goggle firmly in place on safety hats when not in use. Standard Pack: 1

| DESCRIPTION | PART # | |
|-----------------|---------|---------|
| GOGGLE RETAINER | 3000057 | [10511] |

GOGGLE GUARDIAN™



Goggle Guardian™ covers the lens of goggles to keep them clean and scratch free. Standard Pack: 1

| DESCRIPTION | PART # | |
|---------------------------|---------|---------|
| GUARDIAN, STARS & STRIPES | 3000059 | [10514] |
| GUARDIAN, BLACK | 3000058 | [10512] |



Shown in image: #3000001 - Model K Headgear

FACESHIELD FEATURE

- Larger sizes provide additional protection from top, bottom and sides.
- All Jackson Safety® and Huntsman® faceshields meet or exceed ANSI Z87.1 standards for secondary eye protection. Primary eye protection (safety eyewear) required with use of these products in accordance with ANSI Z87.1.
- Available in Polycarbonate, Propionate, Acetate, APCP™, PETG and Mesh.
- Excellent with the 170-SB headgear or Huntsman® Model K.

MATERIAL SELECTOR GUIDE

| MATERIAL | SHAPE | IMPACT RESISTANCE | SCRATCH RESISTANCE | HEAT RESISTANCE | OPTICS |
|---------------|--------------|-------------------|--------------------|-----------------|--------|
| POLYCARBONATE | MOLDED/SHEET | BEST | BETTER | BEST | BEST |
| PROPIONATE | MOLDED | LIMITED | GOOD | GOOD | BETTER |
| ACETATE | SHEET | LIMITED | BEST | BETTER | BEST |
| APCP™ | SHEET | LIMITED | BETTER | BETTER | GOOD |
| PETG | SHEET | LIMITED | BETTER | BETTER | GOOD |

POLYCARBONATE

Optical-grade .060" thick polycarbonate from extruded sheets or injection molded resin provide superior secondary impact protection and increased scratch resistance. Available molded or flat - 15.5" x 8". Clear, IRUV 3.0 and IRUV 5.0. Meets or exceeds ANSI Z87.1+

PROPIONATE

Injection molded, .060" thick propionate offers distortion-free optics. Available in clear, dark green and IRUV 5.0.

ACETATE

High-grade cast sheet acetate available in .040" and .060" thickness protects against dust and chemical splash. Available in clear, light green and dark green with the option of aluminum bound or unbound.

APCP™

.040" thick polyester based resin offers lightweight comfort and economical protection. Low haze and high gloss optics. Available in clear with option of aluminum bound or unbound.

PETG

Provides quality protection at an economical price. Ideal for any worker who needs protection and is not exposed to high heat applications. Offers good scratch resistance and distortion free optics. Available un-molded in clear and dark green.

40-MESH BLACK STEEL SCREEN

Not intended for impact protection. Apply over a faceshield to dissipate heat, preventing faceshield from warping in high heat applications.

WARNING: APPLICATIONS & SAFETY
FACESHIELDS DO NOT PROVIDE UNLIMITED EYE AND FACE PROTECTION - PRIMARY EYE PROTECTION (SAFETY EYEWEAR OR GOGGLES) MUST BE WORN.

JACKSON SAFETY FACESHIELDS

| PART # | OLD # | DESCRIPTION | DIMENSIONS | PK | BOUND/UNBOUND |
|----------------------|-----------|------------------------|--------------------|----|---------------|
| POLYCARBONATE | | | | | |
| 3002835* | 0754-9975 | 34-60 CLEAR BULK | 8" X 15.5" X .060" | 50 | UNBOUND |
| 3002832** | 0754-0415 | 34-60-PC CLEAR, MOLDED | 8" X 15.5" X .060" | 12 | UNBOUND |
| 3009492* | 0754-0048 | 34-60 CLEAR | 8" X 15.5" X .060" | 12 | UNBOUND |
| 3002813** | 0754-0034 | 34-63 IRUV 3.0 | 8" X 15.5" X .060" | 12 | UNBOUND |
| 3002810* | 0754-0031 | 34-65 IRUV 5.0 | 8" X 15.5" X .060" | 12 | UNBOUND |
| 3002838* | 0754-9979 | 34-65 IRUV 5.0 BULK | 8 X 15.5" X .060" | 50 | UNBOUND |
| PROPIONATE | | | | | |
| 3002828 | 0754-0205 | 812-60 CLEAR | 8" X 12" X .060" | 12 | UNBOUND |
| 3002844 | 0754-9990 | 812-60 CLEAR, BULK | 8" X 12" X .060" | 50 | UNBOUND |
| 3002830 | 0754-0215 | 915-60 CLEAR | 9" X 15.5" X .060" | 12 | BOUND |
| 3002843 | 0754-9988 | 915-60 CLEAR, BULK | 9" X 15.5" X .060" | 50 | UNBOUND |
| 3002831 | 0754-0218 | 915-63 DARK GREEN | 9" X 15.5" X .060" | 12 | UNBOUND |





faceprotection

JACKSON SAFETY FACESHIELDS

| PART # | OLD # | DESCRIPTION | DIMENSIONS | PK | BOUND/UNBOUND |
|--------------------------------|-----------|------------------------------|--------------------|----|---------------|
| ACETATE | | | | | |
| 3002805 | 0754-0017 | 6040 CLEAR | 6" X 12" X .040" | 12 | BOUND |
| 3002806* | 0754-0018 | 8040 CLEAR | 8" X 12" X .040" | 24 | UNBOUND |
| 3002824 | 0754-0118 | 8040-U CLEAR | 8" X 12" X .040" | 50 | UNBOUND |
| 3002815 | 0754-0037 | 8041 LIGHT GREEN | 8" X 12" X .040" | 12 | BOUND |
| 3002816* | 0754-0038 | 8042 DARK GREEN | 8" X 12" X .040" | 12 | BOUND |
| 3002846* | 0754-9993 | 8042 DARK GREEN, BULK | 8" X 12" X .040" | 50 | BOUND |
| 3002808* | 0754-0029 | 34-40 CLEAR | 9" X 15.5" X .040" | 24 | BOUND |
| 3002848* | 0754-9996 | 34-40 CLEAR, BULK | 9" X 15.5" X .040" | 50 | BOUND |
| 3002825* | 0754-0129 | 34-40-U CLEAR | 9" X 15.5" X .040" | 12 | UNBOUND |
| 3002817* | 0754-0039 | 34-41 LIGHT GREEN | 9" X 15.5" X .040" | 12 | BOUND |
| 3002818* | 0754-0040 | 34-42 DARK GREEN | 9" X 15.5" X .040" | 24 | BOUND |
| 3002845* | 0754-9992 | 34-42 DARK GREEN, BULK | 9" X 15.5" X .040" | 50 | BOUND |
| 3002826 | 0754-0132 | 1940-U CLEAR | 9" X 19.5" X .040" | 12 | UNBOUND |
| 3002807 | 0754-0020 | 8060 CLEAR | 8" X 12" X .060" | 12 | BOUND |
| 3002809* | 0754-0030 | 34-60 CLEAR | 9" X 15.5" X .060" | 12 | BOUND |
| 3002847* | 0754-9994 | 8040 CLEAR, BULK | 9" X 15.5" X .040" | 50 | BOUND |
| APCP™ | | | | | |
| 3002821 | 0754-0047 | 34-40-AP CLEAR | 9" X 15.5" X .040" | 50 | BOUND |
| 3002836 | 0754-9977 | 34-40-AP-U CLEAR | 9" X 15.5" X .040" | 50 | UNBOUND |
| BLACK MESH STEEL SCREEN | | | | | |
| 3002812 | 0754-0033 | 40-MESH STEEL SCREEN | 9" X 15.5" | 12 | BOUND |
| 39 FIBRE | | | | | |
| 3002811 | 0754-0032 | 39 FIBRE FILTER PLATE HOLDER | 6.5" X 12" | 12 | UNBOUND |

HUNTSMAN® FACESHIELDS

| PART # | OLD # | DESCRIPTION | DIMENSIONS | PK | BOUND/UNBOUND |
|----------------------|-------|---------------------------|---------------------|----|---------------|
| POLYCARBONATE | | | | | |
| 3005377 | 22655 | 4200 LB CLEAR | 10" X 20" X .040" | 36 | UNBOUND |
| 3005378 | 22663 | 8140 LB CLEAR | 8" X 15.5" X .040" | 36 | UNBOUND |
| 3009531 | 15057 | 8154 PLF | 8" X 15.5" X .040" | 12 | UNBOUND |
| 3005371 | 22643 | 8154 LB CLEAR | 8" X 15.5" X .040" | 25 | BOUND |
| 3005372 | 22644 | 8154 LB CLEAR | 8" X 15.5" X .040" | 36 | UNBOUND |
| 3000169 | 15133 | 8156P CLEAR, MOLDED | 8" X 15.5" X .060" | 24 | UNBOUND |
| 3005381 | 22677 | 8156 CLEAR, MOLDED | 8" X 15.5" X .070" | 50 | UNBOUND |
| 3005374 | 22646 | 8156 LB CLEAR | 8" X 15.5" X .060" | 25 | BOUND |
| 3005375 | 22647 | 8156 LB CLEAR | 8" X 15.5" X .060" | 36 | UNBOUND |
| 3005385 | 22701 | 9196 LB CLEAR | 9" X 19.25" X .060" | 36 | UNBOUND |
| 3000171 | 15137 | 10206P CLEAR, MOLDED | 10" X 20" X .060" | 24 | UNBOUND |
| 3000162 | 15095 | 10206G GOLD, MOLDED | 10" X 20" X .060" | 1 | UNBOUND |
| 3005379 | 22667 | 8154 LB DARK GREEN | 8" X 15.5" X .040" | 36 | UNBOUND |
| 3005373 | 22645 | 8154 LB MEDIUM GREEN | 8" X 15.5" X .040" | 36 | UNBOUND |
| 3000449 | 22690 | 8154 WITH CHIN CUP, CLEAR | 8" X 15.5" X .040" | 12 | UNBOUND |
| 3005386 | 22702 | 9194 LB CLEAR | 9" X 19.25" X .060" | 36 | UNBOUND |
| PROPIONATE | | | | | |
| 3000173 | 15039 | 8156PP CLEAR | 8" X 15.5" X .060" | 24 | UNBOUND |
| 3000159 | 15092 | H9156-5 IRUV 5.0 | 9" X 15.5" X .060" | 12 | UNBOUND |

HUNTSMAN® FACESHIELDS

faceprotection

| PART # | OLD # | DESCRIPTION | DIMENSIONS | PK | BOUND/UNBOUND |
|----------------|-------|---------------------------|--------------------|-----|---------------|
| ACETATE | | | | | |
| 3000117* | 15012 | 8124 CLEAR | 8" X 12" X .040" | 24 | BOUND |
| 3000152* | 15085 | 8124 CLEAR, BULK | 8" X 12" X .040" | 50 | BOUND |
| 3000121 | 15023 | 6154 CLEAR | 6" X 15.5" X .040" | 24 | BOUND |
| 3000122* | 15026 | 8154 CLEAR | 8" X 15.5" X .040" | 24 | BOUND |
| 3000155* | 15088 | 8154 CLEAR, BULK | 8" X 15.5" X .040" | 75 | BOUND |
| 3000128* | 15033 | 8154 LB CLEAR | 8" X 15.5" X .040" | 24 | UNBOUND |
| 3000129 | 15035 | 8154MLF MEDIUM GREEN FLAT | 8" X 15.5" X .040" | 12 | BOUND |
| 3000124* | 15028 | 8154D DARK GREEN | 8" X 15.5" X .040" | 24 | BOUND |
| 3000156* | 15089 | 8154D DARK GREEN, BULK | 8" X 15.5" X .040" | 75 | BOUND |
| 3000130 | 15036 | 8154 LB DARK GREEN | 8" X 15.5" X .040" | 12 | UNBOUND |
| 3000125 | 15030 | 8156 CLEAR | 8" X 15.5" X .060" | 24 | BOUND |
| 3000143 | 15069 | 8156M MEDIUM GREEN | 8" X 15.5" X .060" | 24 | BOUND |
| 3000133* | 15039 | H9154 CLEAR | 9" X 15.5" X .040" | 24 | BOUND |
| 3000157* | 15090 | H9154 CLEAR, BULK | 9" X 15.5" X .040" | 75 | BOUND |
| 3000134 | 15040 | H9154M MEDIUM GREEN | 9" X 15.5" X .040" | 24 | BOUND |
| 3000135 | 15041 | H9154D DARK GREEN | 9" X 15.5" X .040" | 24 | BOUND |
| 3000158 | 15091 | H9154D DARK GREEN, BULK | 9" X 15.5" X .040" | 75 | BOUND |
| 3000136 | 15051 | H9194 CLEAR | 9" X 19.5" X .040" | 24 | UNBOUND |
| 3000411 | 22029 | 9154 CHIN CLEAR | 9" X 15.5" X .040" | 24 | UNBOUND |
| 3000146 | 15076 | 9204 CHIN CLEAR | 9" X 20" X .040" | 12 | UNBOUND |
| 3000450* | 22740 | 9154 CLEAR | 9" X 15.5" X .040" | 24 | BOUND |
| 3000451 | 22741 | 8124 DARK GREEN | 8" X 12" X .040" | 24 | BOUND |
| 3000452 | 22742 | 9154 DARK GREEN | 9" X 15.5" X .040" | 50 | BOUND |
| 3000115 | 15009 | 6124 CLEAR | 6" X 12" X .040" | 24 | BOUND |
| 3000123 | 15027 | 8154M MEDIUM GREEN | 8" X 15.5" X .040" | 24 | BOUND |
| 3000422 | 22046 | H9194D DARK GREEN | 9" X 19" X .040" | 60 | UNBOUND |
| PETG | | | | | |
| 3000151 | 15084 | 8154PETGLF CLEAR | 8" X 15.5" X .040" | 100 | UNBOUND |
| 3005376 | 22648 | 8154LB CLEAR | 8" X 15.5" X .040" | 36 | UNBOUND |
| 3005382 | 22681 | 8154LB MEDIUM GREEN | 8" X 15.5" X .040" | 36 | UNBOUND |
| 3005384 | 22699 | 8154LB CLEAR, BULK | 8" X 15.5" X .040" | 100 | UNBOUND |
| 3005399 | 22761 | ECONOMY 8154LB CLEAR | 8" X 15.5" X .040" | 100 | UNBOUND |
| MESH | | | | | |
| 3000127 | 15032 | 815 WIRE SCREEN | 8" X 15.5" X .020" | 12 | BOUND |
| 3005383 | 22692 | 6513 WIRE SCREEN | 15" X .009" | 30 | BOUND |

MODEL K HEADGEAR



Model K ratchet headgear with spark deflector secures 12" or 15.5" faceshields. Soft, absorbent wrap-around foam cushioned sweatband gently hugs the natural shape of the head. Model K-10 features pinlock size adjustment. Faceshields sold separately.

| DESCRIPTION | PART # | STANDARD PACK |
|------------------------|-----------------|---------------|
| MODEL K | 3000001 [10000] | 6 |
| MODEL K BULK | 3000006 [10042] | 60 |
| MODEL K W/ 8124 CLEAR | 3000002 [10003] | 12 |
| MODEL K10 | 3000012 [10050] | 6 |
| MODEL K10 BULK | 3000011 [10049] | 60 |
| MODEL K10 W/8124 CLEAR | 3000420 [22042] | 12 |



170-SB & 131-B HEADGEAR



Universal hole pattern. Enables attachment of all Jackson Safety® faceshields to your safety cap. Headgear features large spark deflector and 170-SB has ratchet suspension. 131-B is an economical headgear with non-ratchet suspension. Faceshield sold separately.

| DESCRIPTION | PART # | STANDARD PACK |
|-------------|---------------------|---------------|
| 170-SB | 3002436*[0742-0020] | 12 |
| 170-SB BULK | 3002447*[0742-9802] | 40 |
| 131-B | 3002437 [0742-0021] | 12 |

A-F3000



Economical headgear has a universal hole pattern that holds faceshield firmly in place. Easy ratchet headband for precise fit. Wrap-around cushioned headband gently hugs the natural shape of the head. Both crown and faceshield easily pivot up. Faceshield sold separately. 19-1/2" x 9-1/2" x 14".

| DESCRIPTION | PART # |
|-------------|-----------------|
| A-F3000 | 3005840 [27910] |

CHEMICAL SPLASH PROTECTION

The type of lens material you will need depends on many factors such as strength and the temperature of the chemical. Below is a basic guide for what may be suitable. *Always consult your safety director for the best determination.

| CHEMICAL | ACETATE | POLYCARBONATE | CHEMICAL | ACETATE | POLYCARBONATE |
|-----------------------|--------------------|--------------------|-----------------------|--------------------|--------------------|
| Aromatic Hydrocarbons | Good | Limited Protection | Mineral Spirits | Good | Good |
| Calcium Chloride | Good | Good | Motor Fuel | Good | Limited Protection |
| Carbon Tetrachloride | Good | No Protection | Nitric Acid 10% - 20% | No Protection | Limited Protection |
| Chlorine 10% | Good | No Protection | Nitric Acid 10% | No Protection | Good |
| Citric Acid | Limited Protection | Good | Oil of Turpentine | Good | Good |
| Concentrated Acid | No Protection | Limited Protection | Organic Acids | Limited Protection | Limited Protection |
| Dry Halogen | Limited Protection | Good | Oxidized Acids | Limited Protection | Limited Protection |
| Ether | Good | No Protection | Parafin Oil | Limited Protection | Good |
| Glycerine | Good | Good | Perchlorethylene | Good | No Protection |
| Greases and Oils | Good | Good | Petrol | Good | Limited Protection |
| Heptane | Good | Good | Potassium Hydroxide | No Protection | No Protection |
| Hydrocarbons | Limited Protection | Limited Protection | Sulfuric Acid 70% | No Protection | Limited Protection |
| Hydrochloric Acid 10% | No Protection | Limited Protection | Sulfuric Acid 50% | No Protection | Good |
| Hydroflouric Acid 5% | Limited Protection | Good | Toluene | No Protection | No Protection |
| Inorganic bases | Good | No Protection | Trichloroethylene | No Protection | No Protection |
| Iodine | Good | No Protection | Turpentine | Good | Good |
| Methylene Chloride | No Protection | No Protection | Xylene | Good | No Protection |

Above is a limited list of chemicals, please visit our website at www.jacksonsafety.com for a complete listing.

WARNING: Faceshields do not provide complete chemical protection. Faceshields provide chemical resistance. Exposing a facshield to contact with chemicals and solvents or their vapors can severely reduce the level of face and eye protection.

A hard hat is the most unappreciated piece of protection on a job site, when it should be the most desired. It is an amazing piece of equipment with enormous performance expectations, protection for your brain - your life! Jackson Safety offers unmatched protection, meeting all ANSI Type 1 safety classes (G, E and C) to protect you. No matter what dangers you may encounter, Jackson Safety is on the job. Jackson Safety caps are only the second line of defense, you must be the first. Searching for and understanding potential dangers, and eliminating them are the first line of defense. If head hazards still exist, you can count on Jackson Safety to offer a proven line of products that are specially suited to protect you.

TYPES & CLASSES STANDARDS

Protective helmets are classified according to the specific impact and electrical performance requirements they are designed to meet. All protective helmets in accordance with this standard shall meet either Type I or Type II impact requirements. In addition, all helmets are further classified as meeting Class G, Class E, or Class C electrical requirements.

IMPACT TYPES

Type I: Helmets intended to reduce the force of impact resulting from a blow only to the top of the head.

Type II: Helmets intended to reduce the force of impact resulting from a blow which may receive limited protection off center, lateral or to the top of the head.

ELECTRICAL CLASSES

Class G (General): Class G helmets are intended to reduce the danger of contact exposure to low voltage conductors. Test samples are proof-tested at 2200 volts (phase to ground). However, this voltage is not intended as an indication of the voltage at which the helmet protects the wearer.

Class E (Electrical): Class E helmets are intended to reduce the danger of exposure to high voltage conductors. Test samples are proof-tested at 20,000 volts (phase to ground). However, this voltage is not intended as an indication of the voltage at which the helmet protects the wearer.

Class C (Conductive): Class C helmets are not intended to provide protection against contact with electrical conductors.

COLOR SELECTION CHART

| COLORS | SC-6 | SB6 | SENTRY III | CHARGER | CHARGER VAC | BLOCKHEAD | SC-16 | BC 100 |
|---------------------------|------|-----|------------|---------|-------------|-----------|-------|--------|
| BLACK | | | | X | | | | |
| BLUE [PMS 2935C] | X | X | X | X | X | X | X | X |
| BROWN [462C] | X | | | | | | | |
| GRAY [PMS 430C] | X | X | X | X | | | | X |
| GREEN [PMS 3425C] | X | X | X | X | | X | | X |
| HI-VIZ ORANGE [PMS 1655C] | | | X | X | | X | | X |
| LIME [PMS 381C] | X | | X | X | | | | |
| NEON PINK [PMS 225C] | | | | X | | | | |
| ORANGE [PMS 1165C] | X | X | X | X | X | X | | X |
| PURPLE [2685C] | X | | | | | | | |
| RED [PMS 1797C] | X | X | X | X | X | X | | X |
| SKY BLUE [PMS 291C] | | | X | X | | | | |
| TAN [PMS 468C] | X | | | | | | | |
| YELLOW [PMS 107C] | X | X | X | X | X | X | X | X |
| WHITE | X | X | X | X | X | X | X | X |



Shown in image
 #3013372 - Charger, Neon Pink
 #3016316 - Elite, Blue Mirror Lens

SC-6

THE INDUSTRY HAS SPOKEN!



Meets ANSI Z89.1, Class G, C & E. Smooth dome design. Lightweight, molded from dielectric High Density Polyethylene (HDPE) -- only 12.4 oz. Slotted, impact absorbing design. Accessory slots for attaching additional protection options. Deep nape strap and absorbent cloth sweatband for comfortable fit. 4 pt. ratchet or pinlock suspensions. Can be worn backwards when suspension is reversed. Attaches to 137 Capshield, Model P, 337 Capshield and the 437 Capshield. Standard Pack: 12

SB-6 STUBBY

Short bill design of the SC-6. Ideal for use with welding helmets. 4 pt. ratchet suspension. Standard Pack 12

| DESCRIPTION | PART # |
|-------------|----------------------|
| YELLOW | 3001928* [0740-0081] |
| WHITE | 3001929* [0740-0082] |
| GREEN | 3001930* [0740-0084] |
| BLUE | 3001931* [0740-0085] |
| ORANGE | 3001932* [0740-0086] |
| RED | 3001933* [0740-0087] |
| GRAY | 3001934* [0740-0088] |



| DESCRIPTION | PART# RATCHET | PART# PINLOCK |
|-------------|----------------------|---------------------|
| YELLOW | 3001987* [0740-0441] | 3001952 [0740-0241] |
| WHITE | 3001988* [0740-0442] | 3001953 [0740-0242] |
| GREEN | 3001990* [0740-0444] | 3001954 [0740-0244] |
| BLUE | 3001991* [0740-0445] | 3001955 [0740-0245] |
| ORANGE | 3001992* [0740-0446] | 3001956 [0740-0246] |
| RED | 3001993* [0740-0447] | 3001957 [0740-0247] |
| GRAY | 3001994* [0740-0448] | 3001958 [0740-0248] |
| BROWN | 3020132 | N/A |
| HI-VIZ LIME | 3001998 [0740-0456] | N/A |
| PURPLE | 3001997 [0740-0451] | N/A |
| TAN | 3001999 [0740-0463] | N/A |

| REPLACEMENT PARTS | | | |
|-------------------|---------------------|---------------------|--|
| 4 PT SUSPENSION | 3002428 [0741-0003] | 3004233 [0741-0021] | |
| SWEATBAND | 3000105 [14739] | 3000105 [14739] | |
| 4 PT CHINSTRAP | 3009653 [15597] | 3009653 [15597] | |
| 2 PT CHINSTRAP | 3002430 [0741-0012] | 3002430 [0741-0012] | |



3002428 [0741-0003]
4PT RATCHET



3002433 [0741-0021]
4PT PINLOCK

SENTRY III™

TRANSCEND THE CONVENTIONAL



Meets ANSI Z89.1, Class G, C & E. Low profile, silhouette styled cap. Low riding nape strap prevents cap from slipping. Lightweight, molded from High Density Polyethylene (HDPE) - only weighs 12.5 oz! Accessory slots for attaching additional protection options. 6 pt. ratchet and 6 pt. pinlock suspensions offer two additional points of impact absorbance. Attaches to 137 Capshield, Model C, Model P, A-5500X, 337 Capshield and 437 Capshield. Standard Pack: 12

| DESCRIPTION | PART# RATCHET | PART# PINLOCK |
|---------------|-----------------|-----------------|
| WHITE | 3000064 [14024] | 3000063 [14022] |
| BLUE | 3000072 [14055] | 3000071 [14053] |
| RED | 3000075 [14065] | 3000074 [14063] |
| HI VIZ ORANGE | 3000085 [14101] | 3000084 [14199] |
| LIME | 3000204 [15549] | 3000203 [15548] |
| GRAY | 3000067 [14033] | 3000066 [14031] |
| ORANGE | 3000078 [14073] | 3000077 [14071] |
| GREEN | 3000070 [14047] | 3000069 [14045] |
| SKY BLUE | 3000206 [15551] | 3000205 [15550] |
| YELLOW | 3000061 [14011] | 3000060 [14009] |

| REPLACEMENT PARTS | | | |
|-------------------|---------------------|---------------------|--|
| 6 PT SUSPENSION | 3000095 [14431] | 3000094 [14429] | |
| SWEATBAND | 3000105 [14739] | 3000105 [14739] | |
| 2 PT CHINSTRAP | 3002430 [15597] | 3002430 [15597] | |
| 4 PT CHINSTRAP | 3009653 [0741-0012] | 3009653 [0741-0012] | |



3000095 [14431]
SENTRY 6PT RATCHET



3000094 [14429]
SENTRY 6PT PINLOCK

CHARGER™

SUPERIOR PROTECTION AT AN ECONOMICAL PRICE



Meets ANSI Z89.1, Class G, C & E. Lightweight for comfort, molded from High Density Polyethylene (HDPE) - only 13.5 oz. Contoured dome maximized protection while providing a sleek, low profile. Griptec™ coated bill helps to improve gripping. Trim bill style for greater upward vision, ideal for vision attachment. Low nape strap, and rain trough. Universal slots allow easy attachment of hearing, welding and faceshield accessories. 4 pt. ratchet, pinlock or plastic suspensions. Attaches to 137 Capshield, Model P, Model C, 337 Capshield, A-5500SN and A-5500X. Standard Pack: 12

CHARGER™ VAC

Meets ANSI Z89.1, Class C. Vented design of the popular Charger™. 12 cooling vents that provide the maximum in air circulation for comfort. 4 pt. ratchet suspensions. Attaches to 137 Capshield, Model P, Model C, 337 Capshield, A-5500SN and A-5500X. Standard Pack 12

| DESCRIPTION | PART # |
|-------------|---------|
| WHITE | 3013392 |
| BLUE | 3013393 |
| RED | 3013394 |
| ORANGE | 3013398 |
| YELLOW | 3013400 |



| DESCRIPTION | PART# RATCHET | PART# PINLOCK | PART# PLASTIC |
|---------------|---------------|---------------|---------------|
| WHITE | 3013362 | 3013374 | 3013409 |
| BLUE | 3013663 | 3013375 | 3013412 |
| RED | 3013364 | 3013376 | 3013413 |
| GRAY | 3013367 | 3013379 | 3013417 |
| ORANGE | 3013368 | 3013380 | 3013414 |
| GREEN | 3013369 | 3013381 | 3013415 |
| YELLOW | 3013370 | 3013382 | 3013411 |
| HI-VIZ ORANGE | 3013365 | 3013377 | 3013416 |
| HI-VIZ LIME | 3013366 | 3013378 | 3013410 |
| NEON PINK | 3013372 | 3013384 | 3013420 |
| SKY BLUE | 3013371 | 3013383 | 3013418 |
| BLACK | 3014571 | 3014572 | 3014709 |

REPLACEMENT PARTS

| | | | |
|-----------------|---------|---------|---------|
| 4 PT SUSPENSION | 3013403 | 3013404 | 3013405 |
| SWEATBAND | 3000105 | 3000105 | 3000105 |
| 4 PT CHINSTRAP | 3009653 | 3009653 | 3009653 |
| 2 PT CHINSTRAP | 3002430 | 3002430 | 3002430 |



3013403
CHARGER 4PT RATCHET



3013404
CHARGER 4PT PINLOCK



3013405
CHARGER 4PT PLASTIC

headprotection

BLOCKHEAD™

BETTER BY DESIGN



Meets ANSI Z89.1, Class G, C & E. Full 360° brim protects wearer from nature's elements. Lightweight for comfort, molded from High Density Polyethylene (HDPE) - only 16.3 oz. Smooth dome leaves no crevices for buildup. Reinforced brim ensuring longevity and safety. Anti-glare bill. Griptec™ coated bill improves gripping. Soft, absorbent cloth absorbs sweat keeping you safe and comfortable. 8 pt. ratchet suspension. Attaches to 37 Hatshield. Standard Pack: 10



3014879
BLOCKHEAD 8PT RATCHET

| DESCRIPTION | PART# RATCHET |
|---------------|---------------|
| WHITE | 3014874 |
| BLUE | 3014876 |
| RED | 3014878 |
| ORANGE | 3014877 |
| YELLOW | 3014875 |
| HI-VIZ ORANGE | 3014982 |
| GREEN | 3014902 |
| SUNSHADE | 3000188 |

REPLACEMENT PARTS

| | |
|-----------------|---------|
| 8 PT SUSPENSION | 3014879 |
| SWEATBAND | 3000105 |
| 4 PT CHINSTRAP | 3009653 |
| 2 PT CHINSTRAP | 3002430 |



HEADTURNERS™

YOUR STYLE, YOUR HAT

Meets ANSI Z89.1, Class G, C & E. Smooth dome design with low profile that's desired most by industry professionals. Graphics designed to withstand temperature variances, humidity, and exposure to UV light for long-lasting wear. 4 pt. ratchet suspensions. Attaches to Model H, Model P, Model C and the 137 Capshield. Standard Pack: 12



INFERNO
#3011126



AMERICAN EAGLE
#3000276

| DESCRIPTION | PART# RATCHET |
|----------------|---------------|
| HELLRAISER | 3004888* |
| INFERNO | 3011126* |
| AMERICAN EAGLE | 3000276 |

| FULL BRIM STYLE | |
|-----------------|---------|
| HELLRAISER | 3013040 |
| GLORY | 3013039 |

| REPLACEMENT PARTS | |
|-------------------|---------|
| 4 PT SUSPENSION | 3002428 |
| SWEATBAND | 3002459 |



HELLRAISER
#3004888



HELLRAISER
#3013040



3002428 [0741-0003]
4PT RATCHET



GLORY
#3013039

SC 16 - FIBERGLASS CAP

Meets ANSI Z89.1, Class G, C & E. Fiberglass protection for high heat applications. Smooth dome design, the most desirable by industry professionals. Firm, comfortable fit with low profile. Padded, absorbent brow pad. Accessory slots offer additional protection options. Only weighs 16.8 oz! 4 pt. ratchet suspension. Attaches to 137 Capshield, Model C, 337 Capshield and A-5500SN. Standard Pack: 12



3002428 [0741-0003]
4PT RATCHET

| DESCRIPTION | PART# RATCHET |
|-------------|----------------------|
| YELLOW | 3001980* [0740-0411] |
| WHITE | 3001981* [0740-0412] |
| BLUE | 3001983* [0740-0415] |

| REPLACEMENT PARTS | |
|-------------------|---------------------|
| 4 PT SUSPENSION | 3002428 [0741-0003] |
| SWEATBAND | 3000105 [14739] |



WESTERN OUTLAW™ HARD HAT

Meets ANSI Z89.1, Class G & C. Stylish, comfortable and fits all head sizes. Wide brim for protection against sunlight. 4 pt. ratchet suspension. Standard Pack: 12



| DESCRIPTION | PART# RATCHET |
|-------------|---------------|
| S&W® TAN | 3013273 |
| S&W® GRAY | 3013274 |
| BLACK | 3007313 |
| GRAY | 3010945 |
| TAN | 3010944 |
| WHITE | 3010943 |

| REPLACEMENT PARTS | |
|-------------------|---------|
| 4 PT SUSPENSION | 3000187 |
| SWEATBAND | 3000105 |

*CE CERTIFIED

BC 100 BUMP CAP



CAUTION: Bump caps are not designed for protection against impact from falling or glancing objects. Does not meet ANSI Z89.1 requirements.

Protection from minor bumps where ANSI standards are not required. Lightweight for comfort, molded from High Density Polyethylene (HDPE) - only 8 oz. Smooth dome leaves no crevices for buildup. Comfortable, low profile design. Available with faceshield attachment knobs. Absorbent, terry cloth brow pad. 4-point injection molded suspension. Pinlock sizing from head sizes 6-1/2 to 8-1/4. Standard Pack: 12

| DESCRIPTION | PART NO | DESCRIPTION | PART NO |
|---------------|---------|--|---------|
| YELLOW | 3001936 | BUMP CAP WITH HEADGEAR ATTACHMENT | |
| WHITE | 3001937 | WHITE | 3012332 |
| GREEN | 3001938 | YELLOW | 3012333 |
| BLUE | 3001939 | BLUE | 3012334 |
| ORANGE | 3001940 | GREEN | 3012335 |
| RED | 3001941 | RED | 3012336 |
| HI-VIZ ORANGE | 3012323 | ORANGE | 3012337 |
| GRAY | 3001942 | HI-VIZ ORANGE | 3012338 |
| | | GRAY | 3012339 |

REPLACEMENT PARTS

| | |
|-----------------|---------|
| 4 PT SUSPENSION | 3012340 |
| SWEATBAND | 3009543 |



BUMP CAP WITH HEADGEAR ATTACHMENT

FACESHIELDS FOR BUMP CAP

| | |
|------------------------------|---------|
| FACESHIELD PETG 6X15.5X.040" | 3005392 |
| FACESHIELD PETG 8X15.5X.040" | 3005391 |

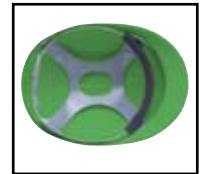

3012340
4 PT PINLOCK BUMP CAP

HI VISIBILITY HEAD PROTECTION

SAFETY CAP COVER

1/2" wide silver beaded reflective tape. Breathable, washable mesh fabric. Adjustable elastic band (one size fits most).



| DESCRIPTION | PART # |
|-------------------------------|---------|
| ORANGE WITH SILVER REFLECTIVE | 3013702 |
| LIME WITH SILVER REFLECTIVE | 3013703 |

REFLECTIVE BALL CAPS

2" wide silver beaded reflective tape. Breathable, washable mesh fabric. Adjustable velcro strap (one size fits most).



| DESCRIPTION | PART # |
|-------------------------------|---------|
| ORANGE WITH SILVER REFLECTIVE | 3013113 |
| LIME WITH SILVER REFLECTIVE | 3013114 |

FLEECE CAPS

1/2" wide silver beaded reflective tape. Fleece fabric for soft touch and additional warmth (one size fits most).



| DESCRIPTION | PART # |
|-------------------------------|---------|
| ORANGE WITH SILVER REFLECTIVE | 3014361 |
| LIME WITH SILVER REFLECTIVE | 3014360 |

headprotection



HARD HAT CUSTOMIZATION PROGRAM



Jackson Safety utilizes the most technologically advanced and innovative pad-printing machine on the market. As with most methods of reproducing process-color images, the creation of near-photographic quality separates the novices from the experts. Jackson Safety pad printing processes utilizes only the highest quality ink to produce fine-line detailing and brilliant color depicting your concise company image, every time. The ability to pad print is only limited by your imagination.

HARD HAT CUSTOMIZATION PROGRAM DETAILS:

- Minimum order of 24 hard hats of the same style
- Up to a maximum of 5 colors per printed location (solid pantones only)
*Ink color may vary based on color of hat being printed on.
- 4 locations per hat/cap: Front, Back, Left Side, Right Side
- Vector artwork is preferred in a .EPS, .PDF, or .AI artwork format
- One measurement at least 5" with a resolution of 600 DPI is acceptable (3000 pixels x 3000 pixels)

These specifications are required and provide you with the best possible results. Supplying camera-ready artwork benefits you by avoiding additional fees and longer lead times. Images may be subject to an artwork fee if they are not production ready. For more information, please contact our Customer Service team at (800)428-8185.

| HAT | FRONT | | BACK | | SIDE | |
|------------|--------|-------|--------|--------|--------|--------|
| | HEIGHT | WIDTH | HEIGHT | WIDTH | HEIGHT | WIDTH |
| SC-6 | 2" | 3" | 2" | 2" | 2" | 3" |
| SENTRY III | 2" | 2" | 2" | 2" | 1-1/4" | 3-1/4" |
| CHARGER | 2" | 3" | 2" | 1-7/8" | 2" | 3" |
| BLOCKHEAD | 2" | 3" | 2" | 2" | 2" | 3" |
| SC-16 | 2" | 3" | 2" | 2" | 2" | 3" |
| BC 100 | 2" | 3" | 2" | 2" | 2" | 3" |

HEADGEAR ATTACHMENTS



| | SC-6/16 | HEADTURNER FULL BRIM | SENTRY III | CHARGER | BLOCKHEAD |
|---------------------------|-----------------|----------------------|------------|---------|-----------|
| 37 HATSHIELD #300242 | | | | | ✓ |
| MODEL H #3000038 | | ✓ | | | |
| 137 CAPSHIELD #3002445 | ✓ | | ✓ | ✓ | |
| MODEL P #3000034 | ✓ SC-6 ONLY | | ✓ | ✓ | |
| MODEL C #3000032 | ✓ SC-16 ONLY | | ✓ | ✓ | |
| 337 CAPSHIELD #3002443 | ✓ | | ✓ | ✓ | |
| A-5500SN #3000447 | ✓ | | | ✓ | |
| 437 CAPSHIELD #3002444 | ✓ SC-6 ONLY | | ✓ | | |
| A-5500X #3000448 | ✓ SC-6 ONLY | | ✓ | ✓ | |

BLADE MOUNTED



437 CAPSHIELD

3002444 [0742-0037]

Totally dielectric, all plastic device for slotted caps. Curved plastic channel fits over the bill of the cap and includes pivoting blades that snap easily into cap slots. Faceshields are secured with integral plastic lugs. Ideal for bill forward user. Attaches to SC-6 and Sentry III. Standard Pack: 12



HUNTSMAN® A-5500X

3000448 [22640]

Lightweight 100% nylon bracket. Pivots up and secures in 3 different positions. Attaches to SC-6, Sentry III, Charger and Charger VAC.



382 B CAP ADAPTER

3002441 [0742-0025]

2002449 40/BOX, BULK

Totally dielectric for slotted caps. Easiest, least costly adapter. Includes an integral spark deflector and pivoting blades. Polyethylene spark deflector. Faceshields secured with integral plastic lugs. Standard Pack: 12



82 B CAPMOUNT ADAPTER

3002438 [0742-0022]

Totally dielectric for slotted caps. Quick detach brackets that join any faceshield and spark deflector with plastic pins to any cap equipped with 87 mounting blades. Polyethylene spark deflector. Standard Pack: 12



82 BM CAPMOUNT ADAPTER

3002446 [0742-0099]

Metal, quick detach brackets join any faceshield and spark deflector with plastic pins to any cap equipped with 87 mounting blades. Polyethylene spark deflector. Standard Pack: 12

CORD MOUNTED



337 CAPSHIELD

3002443 [0742-0036]

Totally dielectric device for non-slotted caps. Curved plastic channel fits over the bill and secures with adjustable rubber headband that stretches around the exterior cap crown. Faceshields are secured with integral plastic lugs. Ideal for bill forward user. Attaches to SC-6, Sentry III, Charger, Charger VAC and SC-16. Standard Pack: 12



HUNTSMAN® A-5500SN

3000447 [22639]

Dielectric. Heavy-duty rubber cord holds bracket in place. Attaches to SC-6, Charger, Charger VAC and SC-16.



282 B CAPMOUNT ADAPTER

3002440 [0742-0024]

2002450 40/BOX, BULK

Mounts faceshield instantly on a wide variety of non-slotted caps with integral plastic lugs. Uses clips pressed over the cap rim for firm fit; removes with thumb pressure. Not to be used on caps with slots and rain troughs. Polyethylene spark deflector. Standard Pack: 12



MODEL K-4 CAP ADAPTER

| DESCRIPTION | PART # | STANDARD PACK |
|----------------|-----------------|---------------|
| MODEL K-4 | 3000046 [10350] | 6 |
| MODEL K-4 BULK | 3000045 [10343] | 60 |

Model K-4 cap adapter holds faceshield firmly on safety caps with heavy duty clips and springs. Features a spark guard with pivoting double slots to hold faceshield in down position. Fits most safety caps. Faceshield sold separately.

****DIELECTRIC MEANS ALL EXPOSED PARTS ARE EITHER PLASTIC OR RUBBER****

CAP COIL SPRING ATTACHMENTS



137 CAPSHIELD

3002445 [0742-0049]

Cap coil spring attachment. Metal device for non-slotted caps. Curved aluminum channel and coil spring attachment. Ideal for bill forward user. Attaches to the SC-6, Sentry III, SC-16, Charger and Charger VAC. Standard Pack: 12



HUNTSMAN® MODEL P CAP ADAPTER

3000034 [10217]

Model P cap adaptor easily attaches faceshield to most safety caps. Huntsman® locking device holds faceshield securely in the up or down position. Turn button attachment will secure faceshield and provide fast, easy attachment and replacement for bill forward facing hats. Faceshield sold separately. Attaches to SC-6, Sentry III, Charger and Charger VAC. Standard Pack: 24

Used with bill forward facing hats



HUNTSMAN® MODEL C CAP ADAPTER

3000032 [10200]

Model C cap adaptor easily attaches faceshield to most safety caps. Huntsman® locking device holds faceshield securely in the up or down position. Ideal for bill backward facing hats. Faceshield sold separately. Attaches to Sentry III, Charger, Charger VAC and SC-16. Standard Pack: 24

Used with bill backward facing hats



182 B CAPMOUNT ADAPTER

3002439 [0742-0023]

Permits attachment of any faceshield and spark deflector combination to any non-slotted cap. Faceshield secured with integral plastic lugs. Polyethylene spark deflector. Standard Pack: 12

HAT COIL SPRING ATTACHMENT



37 HATSHIELD

3002442 [0742-0035]

Metal device for non-slotted hats. Curved aluminum channel and coil spring attachment or allows for attachment of any Jackson Safety faceshield to protective full brim hat. Ideal for bill forward user. Attaches to Blockhead. Standard Pack: 12



MODEL H HAT ADAPTER

3000038 [10250]

Model H Hat Adapter attaches faceshield to most full brim safety hats. Huntsman® locking device holds faceshield securely in the up or down position. Turn button attachment secures faceshield and provides fast easy attachment and replacement. Attaches to Full Brim Headturner Hat. Faceshield sold separately. Standard Pack: 24



TYPES & CLASS STANDARDS

TECHNICAL DATA

All product packaging provides attenuation data and NRR (Noise Reduction Rating).

The following definitions are used in the measurement of noise:

- Hertz - A unit of frequency equal to 1 cycle per second.
- Mean attenuation - The average data derived from all tested subjects.
- Standard deviation - The difference in attenuation between the tested subjects or how well the protection "fits" the individual.

OSHA APPROVAL RULES

1. No agency approves hearing protection.
2. OSHA approves the hearing protector only in accordance to the noise level where it is used. A protector may be approved in one noisy work area but not another because of the level or type (frequency) of noise present.
3. For complete OSHA hearing protection recommendations, see OSHA Occupational Noise Exposure Standard 29 CFR 1910.95 at www.osha.com

WHAT LEVEL OF PROTECTION DO YOU NEED?

All hearing protectors sold by Jackson Safety are tested to the American National Standards Institute (ANSI) S3.19-1974 Standard to receive a Noise Reduction Rating (NRR), which is labeled on all such products as required by the US Environmental Protection Agency (EPA).

This number gives the consumer a method to judge performance among different models of hearing protectors - a higher NRR indicating more effective protection against sound. Some models of hearing protectors have multiple NRR numbers. This reflects the fact that these hearing protectors may be worn with their headbands in different positions.

HIGH
NRR 27-33

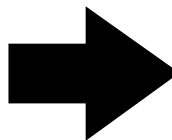

MEDIUM
NRR 25-26

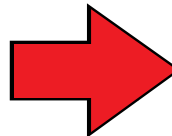

LOW
NRR 21-24

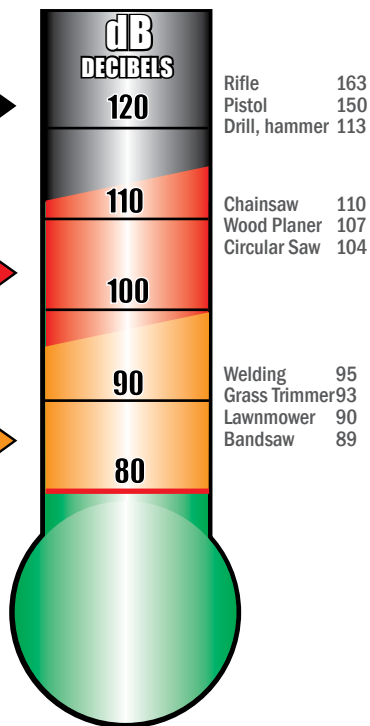
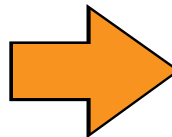

With the numerous options available, the function of a hearing protection device can only be surpassed by alluring colors and trendy shapes. Hearing protection should be taken very seriously and protectors, either muffs or plugs, should be comfortable to wear and offer sufficient attenuation to prevent hearing loss based on individual protection needed.

MUFFS VERSUS PLUGS:

Earplugs as a form of hearing protection are widely accepted and proven. It has been proven time and time again that when worn properly, ear muffs and earplugs offer consistent protection, how then do you choose one from the other? The answer is very specific to your work environment. When Plant conditions such as dust, temperature, and humidity can cause one type of protector to be more suitable than another. For example, ear plugs can be more comfortable in a hot, humid environment, than ear muffs. Also, individual ear canals come in all shapes and sizes. For people with unusually shaped ear canals, fitting may be difficult, and commonly-used insert protectors may be very uncomfortable.

FALCON™ WITH ACTIVE LISTENING

ELECTRONIC HEARING PROTECTION

**NRR
22**



Active listening breaks isolation and offers variable attenuations while still protecting the wearer. Amplifies low level sounds while limiting speaker output to a safe 82 dB. It takes a single AAA battery in each side (included) which lasts up to 250 hours. External battery compartments for easy battery replacement. Dual microphones, volume controls and speakers provide natural directional hearing and compensation for hearing differences between ears.

| | |
|---------------------------|---------------|
| DESCRIPTION | PART # |
| FALCON ELECTRONIC EARMUFF | 3010513 |



Smith & Wesson®

ACTIVE LISTENING

Ultra-slim electronic earmuff with imprinted Smith & Wesson® logo that comes with a customer carry bag. Ergonomically designed left and right ear cups that follow the shape of your ear for a comfortable, low profile fit.

| | |
|-----------------------|---------------|
| DESCRIPTION | PART # |
| S&W® ACTIVE LISTENING | 3011982 |



S&W® SUPPRESSOR EARMUFFS

**NRR
25**



Suppressor earmuffs feature pivoting cup attachment for equal pressure distribution. Contoured, padded headband with rugged non-conductive plastic construction. Easy slide cup adjustment. Smith & Wesson® logo imprinted on each cup.

| | |
|--------------------------|---------------|
| DESCRIPTION | PART # |
| S&W® SUPPRESSOR EARMUFFS | 3011832 |



Smith & Wesson®

VIBE EARMUFF™ & CAPMOUNT

**NRR
23**



Shown left
#3015087 - VIBE 23 Headband

**NRR
26**



Shown left
#3015089 - VIBE 26 Headband

**NRR
29**



Shown left
#3015090 - VIBE 29 Headband

New, innovative design with soft padded headband that adjusts to fit all head shapes and sizes. Dielectric components and durable thermoplastic material retains its shape and pressure for consistent noise reduction. Three levels of protection available. For low, medium and extremely noisy environments.

VIBE 23 is ideal for use with low level noise environments; VIBE 26 is ideal for use with medium level noise environments; VIBE 29 is ideal for use with high level noise environments. All noise levels are available in headband and capmount style.

| DESCRIPTION | PART # |
|-----------------------------------|---------|
| VIBE 23 HEADBAND, 9.3 OZ, NRR 23 | 3015087 |
| VIBE CAPMOUNT, NRR 22 | 3015091 |
| VIBE 26 HEADBAND, 9.8 OZ, NRR 26 | 3015089 |
| VIBE CAPMOUNT, NRR 25 | 3015092 |
| VIBE 29 HEADBAND, 10.9 OZ, NRR 29 | 3015090 |
| VIBE CAPMOUNT, NRR 27 | 3015093 |

hearingprotection

SILENCIO® RBW ORIGINAL EARMUFF

**NRR
23**

UNDER CHIN

**NRR
24**

BEHIND HEAD

**NRR
25**

OVER HEAD



Shown left
#3010417 - ORIGINAL EARMUFF, RED

The RBW Original Earmuff has been protecting people for over 30 years and is still one of the best values around! Fully adjustable steel headband can be worn in 3-positions: over-head, behind-head or under-chin. Individually adjustable ear cups can be removed for sanitation and easy maintenance. Cups can be adjusted vertically and horizontally ensuring the perfect fit for all users.

| DESCRIPTION | PART # |
|--------------------------|---------|
| ORIGINAL EARMUFF, ORANGE | 3010415 |
| ORIGINAL EARMUFF, RED | 3005516 |
| ORIGINAL EARMUFF, BLUE | 3005517 |

SILENCIO® RBW LIQUID EARMUFF

**NRR
21**

UNDER CHIN

**NRR
23**

BEHIND HEAD

**NRR
27**

OVER HEAD



Shown right
#3010450 - LIQUID EARMUFF, RED

The RBW Original Earmuff with liquid filled cushions for added comfort and increased protection. Fully adjustable steel headband can be worn in 3-positions: over-head, behind-head or under-chin. Individually adjustable ear cups can be removed for sanitation and easy maintenance. Cups can be adjusted vertically and horizontally ensuring the perfect fit for all users.

| DESCRIPTION | PART # |
|----------------------|---------|
| LIQUID EARMUFF, RED | 3005521 |
| LIQUID EARMUFF, BLUE | 3005522 |



ONYX™ EARMUFF

**NRR
23**

Shown left
#3015085 - ONYX-23
Headband Earmuff



Lightweight, durable & economical protection for low or medium level noise environments. Ultra-soft ear cushions for comfort and extended wear. Ball & socket pivoting cup attachment provides optimum pressure distribution for maximum noise reduction. Available in 2 different levels of protection.

**NRR
26**

Shown left
#3015086 - ONYX-26
Headband Earmuff



| DESCRIPTION | PART # |
|------------------|---------|
| ONYX 23 HEADBAND | 3015085 |
| ONYX 26 HEADBAND | 3015086 |

STINGER™

**NRR
23**



Economical and lightweight with ultra-soft cushions for extra comfort. Ball and socket pivoting cup attachment for optimum pressure distribution. Cupslides that ratchet for quick and easy adjustment. Slim, lightweight design - only weighs 8.1 oz!

| DESCRIPTION | PART # |
|----------------|---------|
| STINGER, BLACK | 3014960 |

SILENCIO® HP-190W

**NRR
19**



Lightweight, streamlined earmuff allows for use with a welding helmet. Completely dielectric design. Behind the head positioning, with headstrap for secure fit. Oversized cushions for wider, more comfortable pressure distribution.

| DESCRIPTION | PART # |
|-------------|---------------------|
| HP-190W | 3002709 [0748-0020] |

ABOVE-THE-SHOULDER PROTECTION SYSTEM

**NRR
24**



Shown right
#3005132 [14764]
ATS Protection System



Shown right
#3005524 [23463]
Capmate Earmuffs

Complete forestry system includes orange Sentry III™ cap pin-lock suspension, 24 NRR Muff, faceshield carrier and clear polycarbonate face shield. Lightweight and low profile. Snug, comfortable fit. Dielectric for protection against electrical hazards. Component parts also available separately.

| DESCRIPTION | PART # |
|---------------------------------|-----------------|
| ATS PROTECTION SYSTEM | 3005132 [14764] |
| COMPONENT PARTS | |
| ORANGE SENTRY III CAP | 3000077 [14071] |
| FACE SHIELD BRACKET | 3005410 [23291] |
| CLEAR POLYCARBONATE FACE SHIELD | 3005401 [22763] |
| CAPMATE EARMUFFS | 3005524 [23463] |

CAP ADAPTER SYSTEM

**NRR
22**

Shown right
#3002716 [0748-0027]
HFS-22 System



Earmuffs, mounting brackets and cap adapter system provide complete hearing, head and face protection when used with Jackson safety cap, faceshield and safety eyewear. Cap and faceshield sold separately.

| DESCRIPTION | PART # |
|-------------------|---------------------|
| HFS-22 SYSTEM | 3002716 [0748-0028] |
| HP-22-MB EARMUFFS | 3002711 [0748-0022] |



Shown left
#3002711 [0748-0022]
HP-22-MB Earmuffs

SAFE 2/3 PROTECTION SYSTEMS

SAFETY 2 PROTECTION SYSTEM



Shown above
Complete Safe 2 System

Dielectric faceshield system fits most safety caps. Faceshield bracket features an encapsulated stainless steel spring which ensures that the faceshield stays in the selected position. Bracket fits most slotted safety caps and fits most cap-mount earmuffs. Faceshields are shaped to follow the contours of the face for maximum protection. Safety cap, faceshield and earmuffs sold separately.

Shown right
Safe 3 Headgear
with Faceshield



SAFE 3 FACESHIELD HEADGEAR

Faceshield headgear features adjustable headband and unique design that allows the use of earmuffs without interfering with the faceshield. High impact grade of ABS-plastic provides excellent protection. Easy to raise into the rest position when not in use. Faceshields are shaped to follow the contours of the face to provide maximum protection. Faceshields sold separately.

FACESHIELD OPTIONS



Shown left
Clear Polycarbonate Faceshield



Shown right
Steel Mesh Faceshield

| DESCRIPTION | PART NO |
|---|-----------------|
| SAFE 2 FACESHIELD BRACKET | 3005410 [23291] |
| SAFE 3 FACESHIELD HEADGEAR | 3005411 [23292] |
| CLEAR POLYCARBONATE FACESHIELD, 8 X 13 X .040 | 3005401 [22763] |
| NYLON MESH FACESHIELD | 3005415 [23296] |
| STEEL MESH FACESHIELD | 3005413 [23294] |

hearingprotection





S&W® SOFT FOAM EARPLUGS

**NRR
32**



Smith & Wesson® soft, foam earplugs offer superior comfort and outstanding protection. Tapered shape offers easy insertion for any ear canal. 200 individually bagged disposable pair dispenser. (Contains latex.)

DESCRIPTION
S&W® FOAM EAR PLUGS (200/BOX) **PART #**
3013911

hearingprotection

SILENCIO® RED-E-FIT™ EARPLUGS

**NRR
32**



Shown left
#3005542 - RED-E-FIT
Uncorded Earplugs

Soft foam and comfortable design conforms to ear for extended wear. Ideal for high noise environments. Tapered shape offers easy insertion for any ear canal. Brilliant orange in color for quick compliance checks. Individually bagged, one pair per bag. Available in corded, non-corded and economy package. (Contains latex.)

DESCRIPTION
RED-E-FIT EARPLUGS (6 PAIR BLISTER CARD) **PART #**
3003321
RED-E-FIT CORDED EARPLUGS (INDIVIDUALLY WRAPPED, 100/BOX) 3004904
RED-E-FIT UNCORDED EARPLUGS (INDIVIDUALLY WRAPPED, 200/BOX) 3005542 [23530]



Shown left
#3004904 - RED-E-FIT
Corded Earplugs

SILENCIO® SOFT FOAM EARPLUGS

**NRR
29**



Disposable, soft, foam material softens with body heat to fit any shape ear canal for excellent protection and comfort. Display box packaging.

DESCRIPTION
SOFT FOAM EAR PLUGS (INDIVIDUALLY WRAPPED, 100/BOX) **PART #**
3010531



S&W® QUIK-FIT™ CORDED EARPLUGS

**NRR
22**



Triple-flange design offers fast, comfortable insertion and effective noise prevention. Flexible material for a superior seal. Distinctive design allows one size to fit a wide range of ear canals. Washable, reusable. Coded for convenience and includes Smith & Wesson® branded case for convenient carry and storage. Blister card or display packaging available.

| DESCRIPTION | PART # |
|--|---------|
| S&W® QUIK-FIT™ CORDED EARPLUGS (100/ BOX) | 3011831 |
| S&W® BLISTER CARD QUIK-FIT™ CORDED EARPLUGS (PAIR) | 3012155 |

SILENCIO® ECONOMY EARPLUGS

**NRR
26**

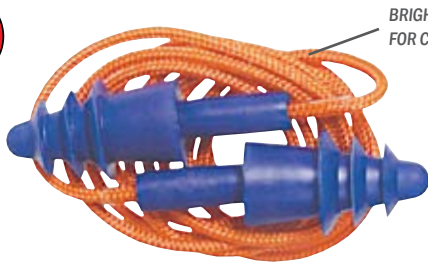

BRIGHT ORANGE CORD IDEAL FOR COMPLIANCE CHECKS

Shown above
#3010526 - Coded Earplugs

Soft, silicone rubber with an internal air cushion for added comfort. Triple flanged for superior fit and seal. Reusable and easy to clean. Available coded and uncoded. Includes carry case that can be Private Branded. Blister card packaging.

| DESCRIPTION | PART # |
|----------------------------------|---------|
| ECONOMY UNCORDED EARPLUGS (PAIR) | 3010522 |
| ECONOMY CORDED EARPLUGS (PAIR) | 3010526 |



Shown left
#3010522 - Uncoded Earplugs

SILENCIO® SILENT PARTNER

**NRR
25**



BRIGHT ORANGE STEM IDEAL FOR COMPLIANCE CHECKS

Soft silicone rubber conforms to the ear canal for an extremely comfortable fit. Reusable and easy to clean. Includes carry case that can be Private Branded. Blister card packaging, sold in pairs.

| DESCRIPTION | PART # |
|--------------------------------|---------|
| SILENT PARTNER EARPLUGS (PAIR) | 3010520 |

hearingprotection



SILENCIO® HEARSAFE™ T230

**NRR
22**

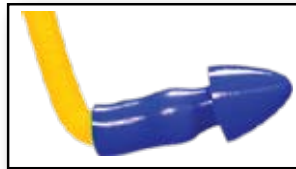

BRIGHT YELLOW STEM IDEAL FOR COMPLIANCE CHECKS

.5 oz. dielectric band with silicone plugs are designed comfortably to quickly mold to the ear canal for custom fit. Low profile band does not interfere with hardhats or eyewear. Excellent value and durability, compared to competitive "name-brands". Blister packaging.

| DESCRIPTION | PART # |
|---------------|-----------------|
| HEARSAFE T230 | 3000460 [23268] |

SILENCIO® SILENT BAND-IT

**NRR
25**

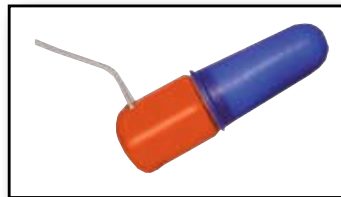
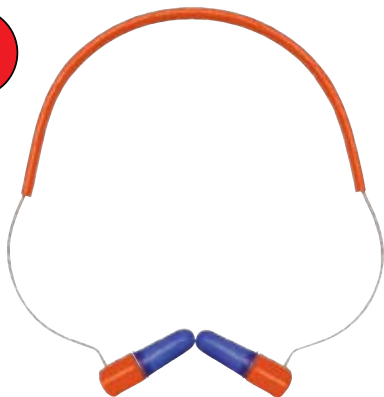

BRIGHT ORANGE STEM IDEAL FOR COMPLIANCE CHECKS

Features an adjustable headband for three position wear to fit over-head, behind-head or under-chin. Durable stainless steel headband fitted with hypo-allergenic silicone earplugs for a reusable and easy to maintain protector. Blister packaging.

| DESCRIPTION | PART # |
|----------------|---------|
| SILENT BAND-IT | 3010543 |

NOISE LEVELS AND DURATION

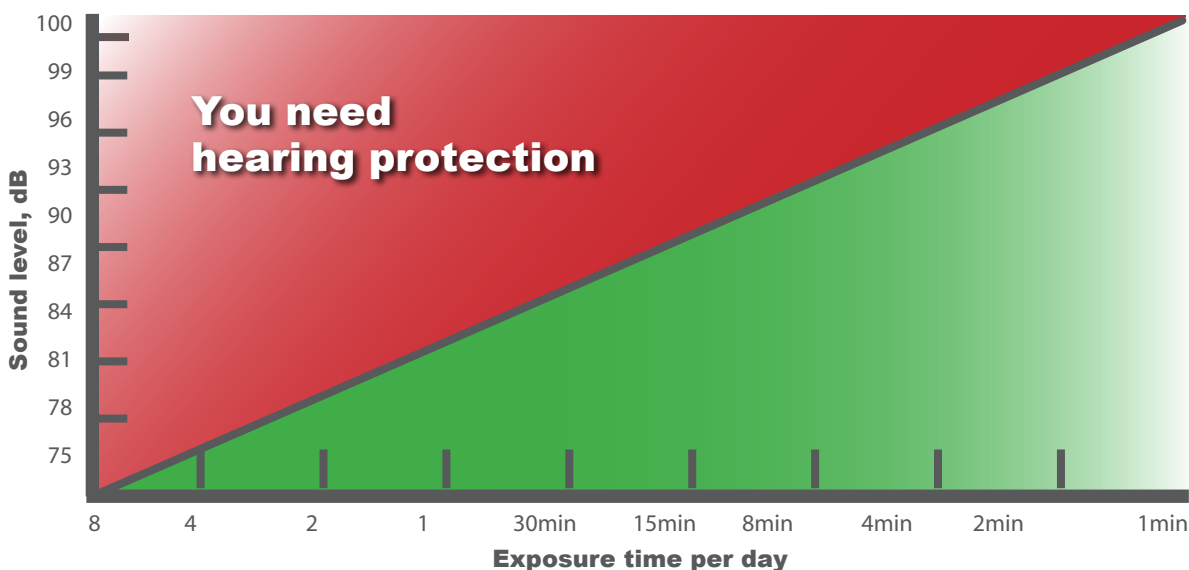

Even a very short exposure to noise is harmful to hearing if hearing protection is not worn. If you are exposed to noise levels and durations indicated by the red area, you must use hearing protectors - in the green area, you may still wish to use protection. High levels of noise exposure over a short period affect the level of sound energy much more than lower levels over longer periods.

DRYBROW® SWEATBAND

Keep cool and prevent perspiration from running into your eyes in hot and humid conditions with Jackson Safety's specialized sweatbands. Ideal for all applications that workers need to be kept cool and comfortable.

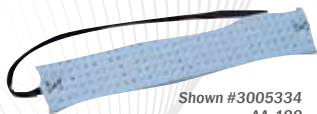

Shown #3005334
AA-100

AA-100

Individually sleeved for increased shelf life.

AA-101

Packaged 100/bag. Not individually sleeved.

AA-103

Packaged 25/bag. Individually sleeved for increased shelf life.



Shown #3005338
DB-801

DB-801

Packaged 100/bag. Economy price.

DB-803

Packaged 25/bag.



Shown #3005336
AA-102

AA-102

Packaged 25/bag. Deluxe clip-on.

| DESCRIPTION | PART # | |
|-------------|---------|---------|
| AA-100 | 3005334 | [22008] |
| AA-101 | 3005335 | [22009] |
| AA-103 | 3005337 | [22011] |
| DB-801 | 3005338 | [22013] |
| DB-803 | 3009557 | [22017] |
| AA-102 | 3005336 | [22010] |

ICY BLUE ONES™ COOLING PRODUCTS

Soak in cold water or chill in freezer for ultimate cooling relief that lasts up to a few hours. Interior polymer crystals absorb up to 200 times their weight in water. A high quality fabric keeps crystals inside and protects against leakage.



Shown #3009560
IB-902E

IB-902E

Headband style keeps brow cool and keeps sweat from dripping into eyes. Wraps around brow with convenient hook and loop fasteners. 27.5" long, 2.5" wide.



Shown #3009561
IB-901C

IB-901C

Bandanna style. Fast, cool relief from heat. Tie around neck or forehead.

| DESCRIPTION | PART # | |
|-----------------------|---------|---------|
| IB-902E, ECONOMY BLUE | 3009560 | [22041] |
| IB901F, AMERICAN FLAG | 3009559 | [22038] |
| IB901E, ECONOMY BLUE | 3005339 | [22039] |
| IB901C, RED/WHITE | 3009561 | [22046] |



SKULL CAPS



SMITH & WESSON® SKULL CAP

Washable flame retardant fabric. Air cushioned, sweat absorbent insert acts as built-in sweatband. Athletic mesh lining keeps your head cooler. One size fits most with tie closer for a secure fit. Standard Pack: 12



HELLRAISER™ SKULL CAP

Mesh lining to help keep head cool. Guaranteed low profile fit. Athletic mesh lining keeps your head cooler. Excellent craftsmanship. Washable flame retardant fabric. Standard Pack: 12

| DESCRIPTION | PART # |
|----------------------|---------|
| S&W® SKULL CAP | 3013052 |
| HELLRAISER SKULL CAP | 3016261 |

WINDGARD™

Keeps wind out, traps warmth and prevents moisture build-up. Knitted flame resistant treated polyester meets IGCFR 1610 Class 1. High visibility colors utilize dielectric material so that it can be worn near electrical hazards. Standard Pack: 12



Shown #3000435
AA-7

AA-7

Warmth for temps 32° to 0°F (0° to -20°C). Snug fitting cap-style fits over most hard hats.



Shown #3000436
AA-8

AA-8

Warmth for temps 32° to 0°F (0° to -20°C). Fits over most safety caps and full-brim styles.



Shown #3005342
AA-9

AA-9

Warmth for temps 0° to -20°F (-20° to -40°C). Full face and neck model protects mouth and cheeks. Fits over most safety caps.

| DESCRIPTION | PART # | |
|-----------------|---------|---------|
| AA-7, RED | 3005341 | [22207] |
| AA-7, NAVY BLUE | 3000434 | [22201] |
| AA-7, ORANGE | 3000435 | [22204] |
| AA-8, RED | 3000436 | [22221] |
| AA-9, RED | 3005342 | [22225] |
| AA-9, NAVY BLUE | 3000437 | [22223] |

seasonal



WINTERLINERS

Through cold and chill, snow, rain and sleet, Jackson Safety offers the industry's most comprehensive line of thermal winterwear that gives workers full protection from the elements. Our winter liners are made from the most technologically advanced fabrics that combine the best of performance features with a number of comfort options.

TEMPERATURE RANGE CODING



45° to 32°F or 8° to 0°C

32° to 0°F or 0° to -20°C

0° to -20°F or -20° to -28°C

The above suggested ranges are to assist in choosing an appropriate liner for various climates.

IMPORTANT

All models are flame retardant treated unless otherwise noted. Flame retardant treated models meet the Federal NFPA701 Standard. Flame resistance is the fabric's ability to self extinguish when source of flame or thermal ignition is removed. Flame resistance is meaningful only when applied to specific tests used to measure the characteristic.

16 CFR 1610, Class I: "Textiles meeting these requirements are generally accepted by the trade as having no unusual burning characteristics." Windgard, Windjammer™ II, IV, 2-N-1 Sport meet 16 CFR 1610, Class I

165



Lightweight protection that can be worn under caps and hats. Two string ties for comfortable, close fit. Dielectric material can be worn near electrical hazards. Inner Liner: Napped Flannel. Standard Pack: 12

| DESCRIPTION | PART # |
|-----------------|-----------------|
| 165 WINTERLINER | 3000438 [22251] |

200



Medium protection that can be worn under caps and hats. Hook and loop fastener for a comfortable, close fit. Dielectric material can be worn near electrical hazards. Outer Fabric: 8 oz. cotton twill; Lining: Acrylic Fleece; Thread: Spun Poly. Standard Pack: 12

| DESCRIPTION | PART # |
|-----------------|-----------------|
| 200 WINTERLINER | 3000440 [22294] |

225 PLUS



Medium protection that can be worn under caps and hats. Meets requirements Class 1 CFR 1610 Flammability of General Apparel. Hook and loop fastener for a comfortable, close fit. Dielectric material can be worn near electrical hazards. Water resistant material. Outer Fabric: Quilted nylon with extra thick foam fill; Lining: Polyester fleece. Standard Pack: 12

| DESCRIPTION | PART # |
|----------------------|-----------------|
| 225 PLUS WINTERLINER | 3000442 [22295] |

250M



Medium protection that can be worn under caps and hats. Hook and loop fastener for a comfortable, close fit. Dielectric material can be worn near electrical hazards. Outer fabric: 8 oz. cotton twill; Lining: Acrylic Fleece. Standard Pack: 12

| DESCRIPTION | PART # |
|------------------|-----------------|
| 250M WINTERLINER | 3005348 [22295] |

305 TSL



Ideal for cold weather environments. Full head and neck coverage with extra-wide wrapped collar. Shoulder-length liner can be tucked into jacket. Hook and loop fastener straps. Outer Fabric: 8 oz. 100% Cotton Twill; Inner Panels: Thinsulate®; Inner shell: Heavy-weight Fleece. Standard Pack: 3

| DESCRIPTION | PART # |
|---------------------|-----------------|
| 305 TSL WINTERLINER | 3000443 [22383] |

325 ULTRA



Ideal for cold weather environments. Can be worn over hearing products. Top section is flame retardant. Bottom section is flame resistant. Plastic zipper for dielectric protection. Detachable bottom section is double layered, heavy spun polyester. Nape piece closes with two buttons. Top Piece: 8 oz. Cotton Twill; Bottom Piece: Nylon Knit; Lining: Brushed 100% Acrylic Fleece (Top Only). Standard Pack: 3

| DESCRIPTION | PART # |
|-----------------------|-----------------|
| 325 ULTRA WINTERLINER | 3000439 [22293] |

375



Ideal for cold weather environments. Long nape offered for extra neck coverage from wind. Dielectric material that can be worn near electrical hazards. Outer Fabric: 8 oz. Cotton Twill; Lining: 16 oz Sherpa. Standard Pack: 3

| DESCRIPTION | PART # |
|-----------------|-----------------|
| 375 WINTERLINER | 3005349 [22300] |

400



Ideal for cold weather environments. Full head and neck coverage with extra-long nape and wrap-around collar. Shoulder length that can be tucked into jacket. Dielectric material can be worn near electrical hazards. Outer Fabric: 8 oz. cotton twill; Lining: 16 oz Sherpa. Standard Pack: 3

| DESCRIPTION | PART # |
|-----------------|-----------------|
| 400 WINTERLINER | 3000441 [22297] |

440 MAX WITH MOUTHPIECE



Ideal for cold weather environments. Can be worn under most caps and hats. Wide neck piece. Lower forehead coverage. Detachable face piece (not shown) for extra cold temperatures. Dielectric material can be worn near electrical hazards. Outer Fabric: Nylon quilt meets Federal Fabric Act 16 CFR Class 1; Lining: 16 oz. Sherpa. Standard Pack: 3

| DESCRIPTION | PART # |
|---------------------|-----------------|
| 440 MAX WINTERLINER | 3005351 [22308] |

WIND JAMMER II



Ideal for cold weather environments. Heavy-duty with lightweight comfort and warmth. Silver with black trim and fastener straps. Nylon quilt meets Federal Fabric Act 16 CFR Class 1. Standard Pack: 12

| DESCRIPTION | PART # |
|----------------|-----------------|
| WIND JAMMER II | 3005347 [22278] |

WIND JAMMER IV



Ideal for cold weather environments. Long nape and wrap-around design provides extra warmth and a snug fit. Silver with black fastener straps and elastic border stitching. Nylon quilt meets Federal Fabric Act 16 CFR Class 1. Standard Pack: 12

| DESCRIPTION | PART # |
|----------------|-----------------|
| WIND JAMMER IV | 3005346 [22277] |

ARCTIC 2-IN-1 SPORT™



Great coverage with reduced drafting. Top section made of fleece with elastic around the face; Bottom section made of spun polyester. Standard Pack: 3

| DESCRIPTION | PART # |
|---------------------------------|-----------------|
| ARCTIC 2-IN-1, ROYAL BLUE/RED | 3004789 [22311] |
| ARCTIC 2-IN-1, SILVER/NAVY BLUE | 3004788 [22316] |

650 NPR

MEETS NFPA 1975



Ideal for cold weather environments. Leather chin-strap Leather/Nomex® tabs to attach to hard hats. Longer nape for neck and lower forehead protection. Dielectric material can be worn near electrical hazards. Retains FR protection throughout life of the product. Outer Shell: 100% Nomex IIIA; Inner Shell: 100% Proban Cotton. Standard Pack: 6

DESCRIPTION **PART #**
650 NPR WINTERLINER 3005354 [22329]

695 NPR

MEETS NFPA 1975



Ideal for cold weather environments. Full head and neck liner with wide wrap-around collar. Universal to fit all head sizes. Leather/Nomex tabs attach to hard hats. Dielectric material can be worn near electrical hazards. Retains FR protection throughout life of the product. Outer Shell: 100% Nomex IIIA; Inner Shell: 100% Proban Cotton. Standard Pack: 3

DESCRIPTION **PART #**
695 NPR WINTERLINER 3005355 [22337]

NOMEX® HOOD



100% Nomex® knitted hood. Double-layered with 100% Nomex® for extra protection around the face. Full head and neck coverage with extra-wide collar. Shoulder length collar can be tucked into jacket. Can be worn under a hard hat or welding helmet as protection against flame and electrical arcs. Retains FR protection throughout life of the product. Standard Pack: 3

DESCRIPTION **PART #**
NOMEX HOOD 3000444 [22402]

| ARC ENERGY EXPOSURES | |
|----------------------|---------------------|
| OUTER | INNER |
| 96 **Cal/Cm2/Second | 76 **Cal/Cm2/Second |

* The length of brittle residue when material is exposed to thermal energy.
**CAL=Calorie=Measure of heat energy.

Flash-Tex™ liners will assist in complying with OSHA 1910.269.

| FLASH-TEX™ | FLAME RESISTANT | | LAUNDRING DATA | | *CHAR LENGTH | |
|--------------------|---|---|-----------------------------|---|--------------|-------|
| | OUTER SHELL | INNER SHELL | OUTER SHELL | INNER SHELL | OUTER | INNER |
| 650 NPR 695 NPR | Nomex® inherently flame resistant NFPA 1975 | Proban® durable flame resistant NFPA 1975 | FR properties last lifetime | Retains FR properties up to 25 industrial washes and 50 domestic washes | 2.4 | 3.5 |

Note: Above data obtained from material manufacturers' testing. For additional technical information, contact Customer Service.

ANSI REFLECTIVE FLEECE CAPS

1/2" wide super bright silver reflective tape. Fleece fabric for soft touch and additional warmth. One size fits most.



DESCRIPTION **PART #**
FLEECE CAP, LIME 3014361
FLEECE CAP, ORANGE 3014360

seasonal



FIRST AID KITS

firstaid



Shown left
#3011186
10 Person Poly Kit

10 PERSON KIT

Available in metal or polyethylene box. Meets ANSI Z308.1-2003. Ideal for small workplaces or vehicles.

| DESCRIPTION | PART # |
|-----------------|---------|
| 10 PERSON METAL | 3011187 |
| 10 PERSON POLY | 3011186 |



Shown right
#3011190
25 Person Metal Kit

25 PERSON KIT

Available in metal or polyethylene box. Meets ANSI Z308.1-2003. Ideal for most work environments, medium businesses and workplaces. Contractor 25 - Meets basic requirements, ideal for most job sites.

| DESCRIPTION | PART # |
|--------------------|---------|
| 25 PERSON METAL | 3011190 |
| 25 PERSON POLY | 3011188 |
| CONTRACTOR 25 POLY | 3011467 |



Shown left
#3011191
50 Person Poly Kit

50 PERSON KIT

Available in metal or polyethylene box. Meets ANSI Z308.1-2003. Ideal for large businesses, manufacturing plants, office complexes and warehouses.

| DESCRIPTION | PART # |
|-----------------|---------|
| 50 PERSON METAL | 3011192 |
| 50 PERSON POLY | 3011191 |

| DESCRIPTION | 10 PERSON KIT | 25 PERSON KIT | CONTRACTOR 25 KIT | 50 PERSON KIT |
|--|---------------|---------------|-------------------|---------------|
| Bandage Assortment | | | | |
| Certi-Strip Adhesive Bandage, Plastic 1"x 3" | | | 1 | 100 |
| Certi-Strip Plastic, XLG | | | | 2 |
| Certi-Strip Plastic, 1"x 3" | 16 | 25 | 50 | |
| Certi-Gauze Pad, 3"x 3" | 4 | 4 | | 4 |
| Certi-Gauze Pad, 4"x 4" | | 1 | | 2 |
| Eye Pad | | 1 | | 2 |
| Certi-Strip, Fingertip | 1 | 1 | | |
| Certi-Strip, Knuckle | 1 | 1 | | |
| Adhesive Certi-Tape, 1/2"x 5 yd. | 1 | 1 | 1 | 1 |
| Ammonia Inhalant 1"x 1" | | 1 | | 2 |
| First Aid Assortment | | | | |
| BZK Towelette | 10 | 10 | 10 | |
| First Aid Cream, 1 gm | | | | 1 |
| Certi-Burn Cream, 1 gm | 6 | 6 | 6 | 6 |
| Insect Sting Wipe-up | 1 | 2 | 2 | 3 |
| Alcohol Wipe-up | | | | 10 |
| Antiseptic BZK Towlette | | | | 10 |
| Aspirin tablets 2/pkg. | | 2 | | 5 |
| Antibiotic Cream, Certi-Sporyn, 1 gm | | | | 3 |
| PVP Iodine Wipe-ups | | | | 3 |
| Cold Pack, Certi-Cool Junior | 1 | 1 | 1 | 1 |
| Cotton Swabs 3" | | | | 1 |
| Elastic Bandage, Ace Style 2" | | | | 1 |
| Eye Wash, Certi-Ose 20 ml. | | 1 | | 1 |
| Forceps, Plastic 4.5" | 1 | 1 | 1 | 1 |
| Certi-Gauze Roll - 1" x 6 yd. | 1 | | | 1 |
| Certi-Gauze Roll - 2" x 6 yd. | | 1 | 1 | |
| Gloves, Nitrile, Pair M/L | 2 | 2 | 2 | 2 |
| Scissors, Bandage w/ Red Handle 4" | 1 | | | 1 |
| Trauma Pad 5"x 9" | 1 | 1 | 2 | 1 |
| Triangular Bandage 40" | 1 | 1 | 1 | |
| Triangular Bandage w/ 2 Safety Pins 40" | | | | 1 |
| First Aid Facts Sheet | 1 | 1 | 1 | |

DISPOSABLE RESPIRATOR



Not NIOSH approved. Maintenance-free disposable respirator. Low profile design ensures clear vision. Lightweight fiber for comfort and clear communication. Adjustable nose piece for proper fit. Standard Pack: 50 masks per box

| DESCRIPTION | PART # |
|-----------------------|-----------------|
| DISPOSABLE RESPIRATOR | 3005847 [28082] |

N95 DISPOSABLE RESPIRATOR



Features durable, latex-free head straps to withstand tough use. Adjustable metal nose piece helps ensure proper fit. Ideal for dusty environments. Lightweight for comfort and extended wear. Use for protection against non-oil-based solids or liquid particulates. Standard Pack: 20 masks per box

| DESCRIPTION | PART # |
|---------------------------|-----------------|
| N95 DISPOSABLE RESPIRATOR | 3000559 [28083] |

N95 PARTICULATE MASK



Features durable, latex-free head straps to withstand tough use. Adjustable nose piece and a soft foam nose cushion helps ensure proper fit. Lightweight for comfort and extended wear. Inner coating repels moisture that allows workers to breath easier. Easier breathing and less fatigue for workers means better compliance. NIOSH N95 approved. Standard Pack: 20 masks per box

| DESCRIPTION | PART # |
|----------------------------|---------|
| N95 PARTICULATE RESPIRATOR | 3010941 |

N95 PARTICULATE W/VALVE



A new valve design that helps provide workers a cooler and more comfortable experience. Features durable, latex-free head straps to withstand tough use. Adjustable metal nose piece and soft foam nose cushion helps ensure proper fit. Lightweight for extended wear. Easier breathing and less fatigue for your workers means better compliance. NIOSH N95 approved. Standard Pack: 10 masks per box

| DESCRIPTION | PART # |
|-------------------------------------|---------|
| N95 PARTICULATE RESPIRATOR W/ VALVE | 3010947 |

respiratory



Chromium exists in a number of different valence states and the hexavalent form has been associated with significant adverse health effects including cancer, damage to the nasal tissues, asthma and allergic skin reactions. As of February 28, 2006, OSHA published a new standard on hexavalent chromium lowering the PEL (Permissible Exposure Limit) to .005 mg/m³ (5 ug/m³) and established an Action Limit of 0.0025 mg/m³ (2.5ug/m³). This new standard only covers exposure to the hexavalent form of chromium but it covers any chromium species with this valence state.

Jackson Safety recommends contacting an Industrial Hygienist to have the air at your facility evaluated to determine the proper application of the ShadowAire system to meet the requirements of your environments.

SHADOWAIRE II™ POWERED AIR PURIFYING RESPIRATOR

Jackson Safety's Powered Air Purifying Respirator - ShadowAire II features tough industrial strength construction with a flame retardant and crush resistant hose -- the ONLY one in the industry. The airflow exceeds NIOSH standard by over 25%. The NiMh battery is 40% lighter than NiCad battery. Sleek plenum design allows for more head room and attaches to helmet instead of headgear for comfort. Available with the NexGen™ EQC, latest in auto-darkening technology. Audible alarm alert low battery and low airflow. Adjustable belt with lumbar support. Fast Charger provides quick, reliable battery charging. Meets OSHA requirements & NIOSH approved. Includes carry bag.

| DESCRIPTION | PART # | |
|---|---------|-------------|
| PAPR AND P3 FILTERS, NEXGEN EQC W/ 2-4 HOUR BATTERIES | 3002551 | [0744-1045] |
| PAPR AND P3 FILTERS, NEXGEN EQC W/ 8 HOUR BATTERY | 3002552 | [0744-1050] |
| PAPR AND P3 FILTERS, SHADE 10 W/ 2-4 HOUR BATTERIES | 3002544 | [0744-1024] |
| PAPR AND P3 FILTERS, SHADE 10 W/ 8 HOUR BATTERY | 3002550 | [0744-1032] |

Note: The ShadowAire II protects against radio nuclids, asbestos and other dusts, mists and fumes with time weighted averages less than 0.05 Milligrams per cubic meter when used properly with P3 filters. Always consult with a safety specialist before choosing a PAPR.



REPLACEMENT PARTS

| DESCRIPTION | PART # | DESCRIPTION | PART # |
|--|---------------------|--|---------------------|
| COMPLETE BLOWER UNIT (INCLUDES BLOWER UNIT, BELT, AIR FLOW INDICATOR & BREATHING HOSE) | 3002856 [0744-0518] | 8HR NIMH BATTERY | 3002871 [0756-0536] |
| P3 FILTER (6PK) | 3002861 [0756-0523] | BLOWER UNIT | 3002857 [0756-0519] |
| FAST CHARGE BATTERY CHARGER (4 HR) | 3002862 [0756-0525] | BREATHING HOSE | 3002859 [0756-0521] |
| OVERNIGHT BATTERY CHARGER (8 HR) | 3002873 [0756-0538] | AIR FLOW INDICATOR | 3002860 [0756-0522] |
| PLENUM ASSEMBLY | 3002863 [0756-0526] | BELT | 3002865 [0756-0528] |
| FACE SEAL (3PK) | 3002864 [0756-0527] | GASKET SEAL FOR BREATHING HOSE | 3002866 [0756-0529] |
| 4HR NIMH BATTERY | 3002858 [0756-0520] | BELT BRACKET | 3002867 [0756-0530] |
| 592 SAIL HELMET ASSEMBLY | 3010546 | SHADOWAIRE II SHELL WITH VELCRO STRIPS | 3002868 [0756-0532] |

weldingsafety



EXCLUSIVE AUTO-DARKENING TECHNOLOGY

Exclusive, cutting-edge technology empowers Jackson Safety to provide superior auto-darkening units. Innovative technology includes unparalleled features such as: 3N1 technology for three modes of operation (grind, cut, and weld), ClimaSensor™ technology, EMI coating, and Intellisense™. Jackson Safety battery operated EQCs also have the fastest switching speed in the industry by utilizing the same surface mode (Pi) technology in the EQCs as seen in advanced aircraft cockpit displays, 3-D viewing systems and nuclear flash protection devices. With state-of-the-art technology that can perform in these extreme environments, rest assured it will withstand your extreme environment as well.

Not only does the cutting edge technology allow Jackson Safety to stand apart from the competition, our Two-Year Performance Guarantee offers our customers a performance promise that can't be beaten. And, with our exclusive EQC Upgrade Program, our customers always have the option to upgrade to a newer lens should their welding needs change or new technology is introduced.

DELAY ADJUSTMENT: used to keep the ADF dark until the bright light from the hot steel has time to decay or drop. It controls the amount of time the lens will stay dark before transitioning back to the light state, after you have stopped the arc. Beneficial when making several consecutive welds in the same area where the light state is not necessary to get set for the next weld. The higher the number, the longer the unit will stay dark after the arc before transitioning to the light state.

SENSITIVITY ADJUSTMENT: allows user to fine tune the unit depending on ambient light (such as the sun, overhead lighting or other welders in close proximity) or arc intensity. This feature allows low amp, DC TIG welding that other units cannot accomplish. The higher the number, the more sensitive the unit will be to ambient light or arc intensity, thereby transitioning to dark with a less intense light.

SOLAR BATTERY LIFE EXTENDER: solar panel that extends the welding hours provided by a set of batteries, thus decreasing battery replacement costs and downtime

INTELLISENSE™: allows the unit to detect welds less than 5 amps. This feature is useful for those who are performing low-amperage welds, primarily low-amp TIG welding.

3N1: provides three modes of operation for the lens: grind (shade 3), oxyfuel gas cutting (shade 5), and weld (shades 9-13). This allows the welder the ability to wear one hood for every welding process, thus eliminating downtime.

AMBER VIEW: the soothing amber color provides greater visibility of the weld with less strain on the eyes.

INDEPENDENT REDUNDANT SENSORS: in units of two or more sensors, if one sensor is blocked or damaged, the unit's performance will not be compromised. Therefore, welders can work in tight areas, where a sensor may be blocked, without any interruptions.

AUTO-OFF: battery maximizing feature that manually shuts-down the unit when not in use or 20 minutes after the last arc is struck.

CLIMASENSOR™ TECHNOLOGY: tests the ambient air temperature three times per minute and automatically adjusts the lens accordingly to ensure a true shade when welding. ClimaSensor™ technology is useful to those who are welding in extremely hot or cold environments.

EMI COATING: a special coating applied to protect the electronics against extreme electromagnetic interference. This coating is essential for welders who generate higher than normal electromagnetic interference, such as TIG welding, particularly AC TIG, and other alternating current welding applications, or are in an environment with a concentration of this interference.

BANDPASS FILTER: a chemical treatment applied to one side of glass inserted in all Jackson EQCs. The chemical treatment only allows visible light to pass, and does not allow Ultraviolet or Infrared radiation to pass thru it. Jackson EQCs bandpass protects to a shade 14, even in the "off" state.

LOW VOLTAGE INDICATOR: when lit, alerts the welder to change the batteries in their EQC. Replacement batteries must be alkaline batteries for optimal performance. Jackson recommends the same battery brand as supplied to ensure a proper fit and connection with the unit.

EASILY SELECT THE RIGHT EQC FOR YOUR APPLICATION

With Jackson Safety's full range of auto-darkening line, there is an auto-darkening option to suit every welders needs.

| Welding Processes | BOSS | Nex Gen | Executive | Master | Pro Variable | Journey Man Variable | Apprentice | Nitro | Solera | Turbo | AutoView 1105VXL | AutoView 1100IVXL | AutoView 1105VLS | 1100BVL Variable |
|-------------------------------|------|---------|-----------|--------|--------------|----------------------|------------|-------|--------|-------|------------------|-------------------|------------------|------------------|
| STICK ELECTRODE A/C. & D/C. | X | X | X | X | X | X | X | X | X | X | X | X | X | X |
| MIG AND PULSE MIG (DELAY) | X | X | X | X | X | X | X | X | X | X | X | X | X | X |
| TIG - A/C. & D/C. | X | X | X | X | X | | | X | | X | X | X | X | |
| LOW AMP TIG (20-50AMP) | X | X | X | X | X | | | | | X | X | X | X | |
| EXTREME LOW AMP TIG (<20 AMP) | X | X | X | X | X | | | | | X | X | X | X | |
| PULSE TIG A/C. & D/C | X | X | X | X | X | | | | | X | X | X | X | |
| INVERTER POWER SUPPLY | X | X | X | X | X | | | | | X | X | X | X | |
| PLASMA ARC | X | X | X | X | X | | | | | X | X | X | X | |
| FLUX CORE | X | X | X | X | X | X | | X | | X | X | X | X | X |
| METAL CORE | X | X | X | X | X | X | | X | | X | X | X | X | X |
| CARBON ARC GOUGING | X | X | X | X | X | X | | X | | X | X | X | X | X |
| TORCH AND GRIND FUNCTION | X | X | AVAIL. | AVAIL. | | | | | | | | | | |

Shown in image: #3018230 Nitro



Shown in image: #3013593 I2 HXL100 with Pro V



Shown in image: #3013586 Yellow Flame HXL100 with NexGen EQC

JACKSON SAFETY AUTO-DARKENING QUICK REFERENCE GUIDE

Jackson Safety offers a wide range of options at competitive prices to fit your needs. Look for the “Good, Better, Best” for our most popular values. All are backed by Jackson’s 2 year performance guarantee and meet ANSI Z87.1 standards.

| | | JACKSON | | | | | | HUNTSMAN | | | | | | | |
|------------------|---------------------------------|---------|---------|-----------|-----------------|--------------|----------------------|------------|-------|--------|-------|------------------|-------------------|------------------|------------------|
| | | BEST | | BETTER | | GOOD | | | | | | | | | |
| | | BOSS | Nex Gen | Executive | Master Variable | Pro Variable | Journey Man Variable | Apprentice | Nitro | Solera | Turbo | Autoview 1105VXL | Autoview 1100IVXL | Autoview 1105VLS | 1100BVL Variable |
| Viewing Area | 3-1/2" X 3-7/8" Window | X | | | | | | | | | | | | | |
| | 2-3/8" x 3-3/4" Window | | X | X | | | | | | | | X | X | | |
| | 1-3/4" x 3-3/4" Window | | | | X | X | | | | | | | | X | |
| | 42 x 96 mm Window | | | | | | | | X | | X | | | | |
| | 1-1/5" x 3-3/4" Window | | | | | | X | X | | X | | | | | X |
| User Adjustments | Sensitivity Adjustment | X | X | X | X | X | | | X | | X | X | X | X | |
| | Fixed Shade 10 | | | | | AVAIL. | AVAIL. | X | | X | | | | | |
| | Variable Shade | X | X | X | X | X | X | | X | | X | X | X | X | X |
| | Delay Adjustment | X | X | X | X | X | | | X | | X | X | X | X | |
| | 3N1 Grind, Cut, Weld | X | X | AVAIL. | AVAIL. | | | | | | | | | | |
| Power Supply | Solar Powered | | | | | | | X | X | X | | | | | |
| | Auto-Off Feature | X | X | X | X | X | X | | | X | X | X | X | X | X |
| | On/Off Switch w/ auto-off | | | X | X | X | | | | | | X | X | X | X |
| | Uses 2 "AAA" Batteries | X | | X | X | X | X | | | | X | X | X | X | X |
| | Uses 2 Lithium "Coin" Batteries | | X | | | | | | | | | | | | |
| | Solar Battery Life Extender | | X | X | X | | | | | | | | | | |
| Helmets | Low Voltage Indicator Lamp | X | X | X | X | X | | | | X | X | X | X | | |
| | Fits HSL 100 or Halo X | X | X | X | X | X | | | | | X | | | | |
| | Fits HSL 1 Series Hoods | | | | | | X | X | | X | | | | | X |
| | Fits 900 Series | | | | | | | | | X | X | X | X | X | X |
| | Fits 90 x 110 Window | | | | | | | | X | | X | | | | |
| Features | Intellisense | X | X | X | X | X | | | | | X | X | X | X | |
| | Single Sensor | | | | | | X | | | | | | | | X |
| | Two Independent Sensors | X | | X | X | X | | X | X | X | | X | X | | |
| | Four Independent Sensors | | X | | | | | | | | | X | | | |
| | Climasensor Technology | | X | | | | | | | | | | | | |
| | EMI Coating | | X | | | | | | | | | | | | |

BEST



Shown in image: #3014755- HLX100 with BOSS EQC mounted on a white charger hard hat

BOSS™ BIG WINDOW EQC®

The BOSS™ by Jackson Safety features 13 square inches of viewing area, the largest in the market! With Jackson's exclusive amber view lens, the BOSS™ allows greater visibility of the weld with less strain on the eyes. The BOSS™ is paired with the following must-have features for welding:

- Versatile: 3N1 Weld (9-12), Grind (3), and Cut (5) mode
- Sensitivity & delay adjustments
- Variable shade 9-12
- Intellisense technology allows unit to detect welds less than 5 amps-ideal for low amp tig
- Two independent sensors
- Mag lens adaptable
- 4 x 5 cartridge fits Shadow and Halo X helmets



HSL100 GUN METAL
3014754



HLX100 BLADE RUNNER
3016340



HXL100 F
3016263



HLX100 YELLOW FLAME
3016262

DESCRIPTION

BOSS EQC CARTRIDGE ONLY
HSL100 GUN METAL W/BOSS
HLX100 HEAVY METAL W/BOSS
HLX100 YELLOW FLAME W/BOSS
HXL100 F W/ BOSS
HLX100 BLADE RUNNER W/BOSS
HLX100 SPEED W/BOSS

BOSS RETAINER FOR HLX100, HSL100
BOSS BACK COVER PLATE
270-S HEADGEAR
WELDING HELMET BAG
REPLACEMENT SWEATBAND, 2 PACK

PART

3014753*
3014754*
3014755*
3016262*
3016263*
3016340*
3016336*

3015040
3015039
3002669
3010811
3011537

NEED VISION ASSISTANCE?

ADD A MAG LENS!

| | | |
|------------------------|---------|-------------|
| 2 X 4 FOCAL POWER 1.00 | 3002741 | [0752-0063] |
| 2 X 4 FOCAL POWER 1.25 | 3002742 | [0752-0064] |
| 2 X 4 FOCAL POWER 1.50 | 3002743 | [0752-0065] |
| 2 X 4 FOCAL POWER 1.75 | 3002744 | [0752-0066] |
| 2 X 4 FOCAL POWER 2.00 | 3002745 | [0752-0067] |
| 2 X 4 FOCAL POWER 2.25 | 3002746 | [0752-0068] |
| 2 X 4 FOCAL POWER 2.50 | 3002747 | [0752-0069] |

*Z94.3 COMPLIANT *CE CERTIFIED

JACKSON SAFETY ADF HELMETS CARRY A TWO YEAR PERFORMANCE GUARANTEE AND MEETS ANSI Z87.1+ STANDARDS



Shown in image
#3002515 - HSL100 with NexGen EQC

NEXGEN™ EQC®

The NexGen™ by Jackson Safety is truly the next generation of auto-darkening for the welding specialist. Featuring four sensors in a staggered design to eliminate blocked sensors and soft touch controls to eliminate contaminants, protect from harsh welding environments, Smart View LCD provides fingertip control adjustments and an easy to read digital readout.

- Amber view lens provides greater visibility of the weld with less strain on the eyes
- Intellisense technology allows unit to detect welds less than 5 amps - ideal for low amp tig
- Versatile: 3N1 Weld (9-13), Grind (3), and Torch (5) mode
- Protective coating shields EQC from extreme electromagnetic interference
- Integrated ClimaSensors™ register ambient temperature three times per minute and adjusts EQC shade accordingly to ensure a true welding shade
- Variable shade 9-13
- Sensitivity and delay adjustments
- Auto shut-off after 60 minutes in torch and grind modes and 20 minutes after weld mode
- Replaceable lithium batteries with low battery indicator
- Four independent sensors
- Mag lens adaptable



HXL100 SPEED
3016335



HSL100 BLACK
3002515



HSL100 HELLRAISER
3004628

DESCRIPTION

NEXGEN EQC CARTRIDGE ONLY
HSL100 W/ NEXGEN
HSL100 W/ NEXGEN, BULK -10 PACK
HLX100 YELLOW FLAME W/ NEXGEN
HLX100 RAZOR W/ NEXGEN
HLX100 F W/ NEXGEN
HLX100 HEAVY METAL W/ NEXGEN
HLX100 BLADE RUNNER W/ NEXGEN
HLX100 SPEED W/ NEXGEN
HSL100 HELLRAISER W/ NEXGEN
HSL100 GLORY W/ NEXGEN

NEXGEN RETAINER FOR HSL100 & HLX100
NEXGEN BACK COVER PLATE
270-S HEADGEAR
WELDING HELMET BAG
REPLACEMENT SWEATBAND, 2 PACK

PART

3004384* [0752-0106]
3002515* [0744-0705]
3002585 [0744-9668]
3013586**
3013589**
3013592**
3013595**
3016339**
3016335**
3004628*
3011006*

3002670 [0745-0074]
3002739 [0752-0054]
3002669
3010811
3011537

NEED VISION ASSISTANCE? ADD A MAG LENS!

| | | |
|------------------------|---------|-------------|
| 2 X 4 FOCAL POWER 1.00 | 3002741 | [0752-0063] |
| 2 X 4 FOCAL POWER 1.25 | 3002742 | [0752-0064] |
| 2 X 4 FOCAL POWER 1.50 | 3002743 | [0752-0065] |
| 2 X 4 FOCAL POWER 1.75 | 3002744 | [0752-0066] |
| 2 X 4 FOCAL POWER 2.00 | 3002745 | [0752-0067] |
| 2 X 4 FOCAL POWER 2.25 | 3002746 | [0752-0068] |
| 2 X 4 FOCAL POWER 2.50 | 3002747 | [0752-0069] |

weldingsafety



BETTER



EXECUTIVE EQC®

Features variable shade 9-12, sensitivity and delay adjustments. Intellisense™ technology ideal for low amp tig. Two independent sensors. Requires 2 AAA batteries (included). 3N1 model includes grind, cut and weld modes.

| DESCRIPTION | PART # |
|------------------------------|---------------------|
| EXECUTIVE CARTRIDGE ONLY | 3004391 [0752-0201] |
| HSL100 W/ EXECUTIVE | 3002521 [0744-0751] |
| EXECUTIVE 3N1 CARTRIDGE ONLY | 3004400 [0752-0227] |
| HSL100 W/ EXECUTIVE 3N1 | 3002518 [0744-0750] |



MASTER EQC®

Features variable shade 9-12, sensitivity and delay adjustments. Intellisense™ technology ideal for low amp tig. Two independent sensors. Requires 2 AAA batteries (included). 3N1 model includes grind, cut and weld modes.

| DESCRIPTION | PART # |
|---------------------------|----------------------|
| MASTER CARTRIDGE ONLY | 3004386 [0752-0141] |
| HSL100 W/ MASTER | 3002513* [0744-0660] |
| MASTER 3N1 CARTRIDGE ONLY | 3004399 [0752-0225] |
| HSL100 W/ MASTER 3N1 | 3002519 [0744-0747] |

GOOD



HSL100 BLACK
3004387



HXL100 RAZOR
3013590

PROFESSIONAL EQC®

Features variable shade 9-12, sensitivity and delay adjustments. Also available with a fixed shade 10. Pro Variable also offers Intellisense technology ideal for low amp tig. Two independent sensors. Requires 2 AAA batteries (included).

| DESCRIPTION | PART # |
|--------------------------------|----------------------|
| PRO SHADE 10 CARTRIDGE ONLY | 3002769 [0744-0761] |
| HSL100 W/ PRO SHADE 10 | 3002530* [0744-0665] |
| PRO V CARTRIDGE ONLY | 3004387* [0752-0142] |
| HSL100 W/ PRO V | 3002514* [0752-0211] |
| HSL100 HELLRAISER W/ PRO V | 3011636* |
| HSL100 GLORY W/ PRO V | 3011640* |
| HLX100 YELLOW FLAME W/ PRO V | 3013587* |
| HLX100 I ² W/ PRO V | 3013593* |
| HLX100 RAZOR W/ PRO V | 3013590* |
| HLX100 HEAVY METAL W/ PRO V | 3013596* |



JOURNEYMAN EQC®

Available with variable shade 9-12 or fixed shade 10. Single sensor with auto-off feature. Requires 2 AAA batteries (included).

| DESCRIPTION | PART # |
|--|----------------------|
| JOURNEY MAN VARIABLE 9-12 CARTRIDGE ONLY | 3004394 [0752-0214] |
| HSL1 W/ JOURNEYMAN VARIABLE | 3002533* [0744-0764] |
| JOURNEYMAN SHADE 10 CARTRIDGE ONLY | 3004396 [0752-0216] |
| HSL1 W/ JOURNEYMAN SHADE 10 | 3002535* [0744-0766] |



APPRENTICE EQC®

IDEAL FOR THE HOBBYIST WELDER!
Features fixed shade 10/11. Solar powered - always on and ready to weld. Two independent sensors.

| DESCRIPTION | PART # |
|--------------------|----------------------|
| HSL1 W/ APPRENTICE | 3002516* [0744-0706] |

Huntsman's history is rich in tradition, trust and value for welders. From welding helmets to auto-darkening technology, Huntsman has your welding safety needs covered.

AUTOVIEW 1105VXL 4X4



Variable shade 9-12, sensitivity and delay adjustments. Intellisense™ technology for low amp tig. Four independent sensors with low voltage indicator lamp. Auto-off feature. Requires 2 AAA batteries (included).

| DESCRIPTION | PART # |
|------------------------|-----------------|
| 1105VXL CARTRIDGE ONLY | 3004015 [33097] |
| 951P W/1105VXL | 3000523 [25140] |

AUTOVIEW 1100IVXL



The AutoView 1100IVXL features a Big Window™ viewing area. Variable shade 9-12, sensitivity and delay adjustments. Intellisense™ technology for low amp tig. Two independent sensors with low voltage indicator lamp. Auto-off feature. Requires 2 AAA batteries (included).

| DESCRIPTION | PART # |
|-------------------------|-----------------|
| 1100IVXL CARTRIDGE ONLY | 3004005 [30089] |

AUTOVIEW 1105VLS



Variable shade 9-12, sensitivity and delay adjustments. 1105VLS features Intellisense™ technology for low amp tig. Two independent sensors. Low voltage indicator lamp. Auto-off feature. Requires 2 AAA batteries (included).

| DESCRIPTION | PART # |
|------------------------|-----------------|
| 1105VLS CARTRIDGE ONLY | 3004016 [33098] |
| 1105VS CARTRIDGE ONLY | 3004017 [33099] |
| 951P W/ 1105VS | 3000522 [25139] |

AUTOVIEW BASIC 1100BVL



Variable shade 9-12 with one sensor and auto-off feature. Requires 2 AAA batteries (included).

| DESCRIPTION | PART # |
|------------------------|-----------------|
| 1100BVL CARTRIDGE ONLY | 3004004 [33085] |
| 911P W/1100BVL | 3000524 [25141] |

NEW

NITRO™

The newest member of the Huntsman family, the NITRO offers welders outstanding features at an economical price point.

- Infinitely variable shade 9-13
- Sensitivity and delay adjustments
- Lightweight - only weighs 1 pound fully assembled
- Two independent sensors - ideal for tight spaces
- Always on and ready to weld
- Solar powered - no batteries to replace

| DESCRIPTION | PART # |
|----------------------------|----------|
| BLUE NITRO | 3018230* |
| SMITH & WESSON GHOST FLAME | 3016157 |

| | |
|-------------------------------------|---------|
| NITRO CARTRIDGE ONLY | 3018384 |
| 90110 PC POLYCARBONATE SAFETY PLATE | 3015038 |
| 24 PC BACK SAFETY PLATE | 3016169 |
| REPLACEMENT HEADGEAR | 3002669 |
| WELDING HELMET BAG | 3010811 |
| REPLACEMENT SWEATBAND, 2 PACK | 3011537 |



**ALSO AVAILABLE IN
EYE-CATCHING GRAPHICS**



**Smith & Wesson®
GHOST FLAME**



Smith & Wesson® is a registered trademark of Smith & Wesson Corp used under license by Jackson Safety

weldingsafety

TURBO



Variable shade 9-12, sensitivity and delay adjustments. Two independent sensors with auto-off feature. Low voltage indicator lamp. Requires 2 AAA batteries (included).

| DESCRIPTION | PART # |
|----------------------|-----------------|
| TURBO CARTRIDGE ONLY | 3004013 [30107] |
| 951P W/ TURBO | 3000534 [25209] |

SOLERA



Features an economical lens for the consumer welder. Solar powered - always on and ready to weld! Easy to use, no batteries to change. Fixed shade 10/11 lens with two independent sensors.

| DESCRIPTION | PART # |
|-----------------------|-----------------|
| SOLERA CARTRIDGE ONLY | 3004006 [30090] |
| 981P W/SOLERA | 3000504 [25049] |

*Z94.3 COMPLIANT

HUNTSMAN®

www.jacksonsafety.com | 55

HLX SERIES - HALO X



Shown in image: #3013592 - Halo X F with NexGen EQC

ULTRA LIGHTWEIGHT SHELL - ONLY 6 OUNCES!

Ergonomic, lightweight design reduces neck tension and fatigue. Sleek, balanced design and weight reduces “top-heavy” effect. Hydraflex™ shell provides the ultimate in flexibility and durability. Easily attaches to safety caps for added head protection. High impact, seamless graphic designs. Duralogic™ high index metallic paint.



BLADE RUNNER

BLADE RUNNER W/ BOSS 3016340**
 BLADE RUNNER W/ NEXGEN 3016339**
 BLADE RUNNER W/ SHADE 10 3016337*



SPEED

SPEED W/ BOSS 3016336**
 SPEED W/ NEXGEN 3016335**
 SPEED W/ SHADE 10 3016333*

HSL SERIES - SHADOW®

THE BEST SELLING WELDING HELMET IN THE INDUSTRY!

The narrow shell design is perfect for work in tight spaces, and the Shadow® helmets extended front increases throat protection against sparks, slag, and fumes. The Shadow® helmet also can stand up to radiant heat of 350°F, a minimum 50% improvement over most other thermoplastic shells. All Shadow® helmets come complete with cover plate and shade 10 polycarbonate filter plate. Also available with 187 blades or 386 capmount adapter for attachment to safety caps.



HSL 100
 (4.5" X 5.25" FIXED FRONT)

HSL100 BLACK 3002498** [0744-0504]
 HSL100 BLACK (BULK) 3002581* [0744-9459]
 HSL100-B BLUE 3002499* [0744-0505]
 HSL100-R RED 3002500* [0744-0506]
 HSL100-187 3002502* [0744-0508]
 HSL100-386 3002491* [0744-0352]



HSL 1
 (2" X 4.25" FIXED FRONT)

HSL1 BLACK 3002503** [0744-0512]
 HSL1 BLACK (BULK) 3002579* [0744-9452]
 HSL1-B BLUE 3002504* [0744-0513]
 HSL1-R RED 3002505* [0744-0514]
 HSL1-187 3002511* [0744-0522]



HSL 2
 (2" X 4.25" LIFT FRONT)

HSL2 BLACK 3002507** [0744-0516]
 HSL2 BLACK (BULK) 3002580* [0744-9453]
 HSL2-B BLUE 3002508* [0744-0517]
 HSL2-R RED 3002509* [0744-0518]
 HSL2-187 3002512* [0744-0523]
 HSL2-386 3002490* [0744-0351]
 HSL2-86M 3002481* [0744-0139]



I²

I² W/ BOSS
I² W/ NEXGEN
I² W/ PRO V
I² W/ SHADE 10

3016263**
3013592**
3013593*
3013594*



YELLOW FLAME

YELLOW FLAME W/ BOSS
YELLOW FLAME W/NEXGEN
YELLOW FLAME W/ PRO V
YELLOW FLAME W/SHADE 10

3016262**
3013586**
3013587*
3013588*



RAZOR

RAZOR W/ NEXGEN
RAZOR W/ PRO V
RAZOR W/ SHADE 10

3013589**
3013590*
3013591



HEAVY METAL

HEAVY METAL W/ BOSS
HEAVY METAL W/ NEXGEN
HEAVY METAL W/ PRO V
HEAVY METAL W/ SHADE 10

3014755**
3013595*
3013596*
3013597*

REPLACEMENT PARTS

| | | |
|-----------------------------------|---------|-------------|
| 270-S HEADGEAR | 3002669 | [0745-0036] |
| 54-PC CLEAR SAFETY PLATE | 3002759 | [0752-0040] |
| 427 SHADE 10 4.5X5.25 FILTER LENS | 3000645 | [40037] |
| 1127 SHADE 10 2X4.25 FILTER LENS | 3000652 | [40061] |
| REPL SWEATBAND, 2 PACK | 3011537 | |
| WELDING HELMET BAG | 3010811 | |

ALSO AVAILABLE IN HEAD TURNING GRAPHICS

Shown in image: #3002515- HSL100 with NexGen EQC



HELLRAISER

HSL100 HELLRAISER W/ SHADE 10
HSL100 HELLRAISER W/ PRO V
HSL100 HELLRAISER W/ NEXGEN

3004629*
3011636*
3004628*



GLORY

HSL100 GLORY W/ SHADE 10
HSL100 GLORY W/ PRO V
HSL100 GLORY W/ NEXGEN

3011005*
3011640*
3011006*

H SERIES - HANDSHIELDS



H-500



HM-5

Handshields features fiberglass helmet with injection-molded plastic handle. Available in two curved shell models: H-500 large window and HM-5 Integral 2" x 4.25" front.

DESCRIPTION
H-500 HANDSHIELD
HM-5 HANDSHIELD

PART #
3002469 [0744-0016]
3002474 [0744-0037]

H SERIES



H100-A: LARGE WINDOW

H100-A features 19 square inches of viewing area. To prevent entry of harmful rays, the plate holder is molded into shell with a folded neoprene gasket that seals both the cover and filter plate. Maximum clearance for nose, chin and largest prescription glasses or goggles.

DESCRIPTION
H100-A
170 HEADGEAR

PART #
3002463 [0744-0001]
3002454 [0743-0010]



HM1-A & HM1-PW: 2" X 4.25"

HM1-A features a lightweight helmet design with an inclined top surface of the plate holder which helps resist weld splatter. Shell and plate holder are molded in a single piece.



Also available in a pipe line version, the HM1-PW, that features a white coating on the exterior shell.

DESCRIPTION
HM1-A
HM1-PW
170 HEADGEAR
170-P HEADGEAR

PART #
3002465 [0744-0005]
3002476 [0744-0081]
3002454 [0743-0010]
3002661 [0745-0047]



H9-A: NARROW SHELL

H9-A features a straight front design that provides extended protection to the throat area and better ventilation. Lift front provides flexibility so user does not have to raise hood.

DESCRIPTION
H9-A
170 HEADGEAR

PART #
3002466 [0744-0009]
3002454 [0743-0010]



H2-A: 2" X 4.25"

H2-A features a lightweight helmet design with inclined top surface of plate folder to help resist weld splatter. Lift front provides flexibility so user does not have to raise hood.

DESCRIPTION
H2-A
170 HEADGEAR

PART #
3002464 [0744-0004]
3002454 [0743-0010]



H4-A: NARROW SHELL

H4-A features compact design for use in welding in close quarters.

DESCRIPTION
H4-A
170 HEADGEAR

PART #
3002466 [0744-0009]
3002454 [0743-0010]



HR-2A: RESPIRATOR FIT

HR-2A features a 'bubble' front to accommodate a mask-type respirator for greater worker convenience. NOTE: Welding fumes are not reduced unless accompanied by the proper respirator.

DESCRIPTION
HR-2A
170 HEADGEAR

PART #
3002475 [0744-0069]
3002454 [0743-0010]

"FORTY-NINER"



The "forty-niner" welding helmet features a large window lift-front design with a ratcheting headgear. Durable and lightweight design provides a comfortable fit. Comes standard with a shade 10 filter plate.

| DESCRIPTION | PART # | |
|----------------|----------|-------------|
| 493 BLACK | 3002882* | [0800-0009] |
| 493 BLUE | 3002885 | [0800-0021] |
| 270-S HEADGEAR | 3002669 | [0745-0036] |

ACCESSORIES

PROTECT YOUR GEAR! WELDING HELMET BAG

Made of heavy-duty denier fabric with drawstring closure. Features velcro close front lens pocket and two side mesh tool pockets. Throw the bag over your shoulder when you are ready to go! Fits all Jackson Safety helmets.



| DESCRIPTION | PART # |
|--------------------|---------|
| WELDING HELMET BAG | 3010811 |

BLACK QUILTED SHOP CAP

High grade quilted cotton with sateen sweatband. Available in sizes 6-3/4" to 7-3/4". Not fire retardant.



| DESCRIPTION | PART # |
|---------------------|---------|
| 365 SHOP CAP 6-3/4" | 3000699 |
| 365 SHOP CAP 6-7/8" | 3000700 |
| 365 SHOP CAP 7" | 3000701 |
| 365 SHOP CAP 7-1/8" | 3000702 |
| 365 SHOP CAP 7-1/4" | 3000703 |
| 365 SHOP CAP 7-3/8" | 3000704 |
| 365 SHOP CAP 7-1/2" | 3000705 |
| 365 SHOP CAP 7-5/8" | 3000706 |
| 365 SHOP CAP 7-3/4" | 3000707 |

ALUMINIZED WELD-O-GLASS BACK HAND PAD

Protects the back of welder's glove from weld spatter and high radiant heat. Increases the life of your glove. Helps you to weld longer when exposed to high radiant heat. Provides good mobility for gloved hand. Double layer protection, Wilson Weld-O-Glass 2600 AMA on top and a high temperature glass fabric on the bottom. Sewn and riveted for added durability.

| DESCRIPTION | STOCK ITEM | PART # |
|------------------------------|------------|--------|
| BACK HAND PAD (MIN. ORDER 6) | 3018810 | BHP06 |



WELDING UMBRELLA

Provides great protection from rain or sunlight. Features a lightweight aluminum frame and tilt mechanism. Cover made of Rip-Stop vinyl, which is water resistant, fire retardant and very tear resistant. 6' diameter and 7'; high (diameter may vary by 3").

| DESCRIPTION | PART # |
|------------------------------------|--------|
| BLUE WELDING UMBRELLA | UM6500 |
| YELLOW WELDING UMBRELLA | UM8500 |
| GREEN WELDING UMBRELLA | UM9500 |
| RED, WHITE & BLUE WELDING UMBRELLA | UB7500 |
| SUPPORT BASE | 21127 |



The Huntsman 900 series welding helmets features a lightweight, durable, washable thermoplastic shell. Contour Comfort™ double-lock headgear with Zahnlock™ size adjustment system. All helmets come complete with standard shade 10 filter plate.

**951P**

Big Window™ 4x5.25

951P 3000512** [25066]

**981P**

2x4.25 Fixed front

981P 3000513** [25067]

**930P**

2x4.25 Lift front

930P 3000511 [25065]

**911P**2x4.25 Fixed front with aluminum frame filter plate holder
Ideal for higher heat applications

911P 3000510 [25064]

**990P**2x4.25 Quick-slide filter plate holder
Ideal for tight work environments.

990P 3000514 [25068]

**929P**2x4.25 Inspectors model
No headgear included

929P 3000515 [25070]

800 SERIES LEATHER

The Huntsman 800 series welding helmets features a tough, pliable, breathable leather covering. Ideal for use in overhead welding applications or when working in tight spaces. [Does not include headgear]

**860P**

2x4.25 window

860P LIFT FRONT 3000506** [25052]
860-2 FIXED FRONT 3000507 [25055]**851P**

4x5.25 Big Window™

851P 3000508 [25056]

**870 INSPECTION SHIELD**

Ideal for those who occasionally observe welding

870 INSPECTION SHIELD 3000697 [45004]

400 SERIES

The Huntsman 400 series welding helmets features a heat-resistant vulcanized fiber shell for comfortable, cool, heavy duty welding. "Contour Comfort" double-lock headgear with Zahnlock™ size adjustment system. All helmets come complete with standard shade 10 filter plate. (NOTE: In some damp or wet environments, scotch guarding will prolong useful life. Not to be used for overhead welding.)

Shown in image: #3000496-411P



451P

Big Window™ 4x5.25

451P 3000500** [25030]



411P

2x4.25 Fixed front with aluminum frame filter plate holder
Ideal for higher heat applications

411P 3000496 [25023]



430P

2x4 Lift front

430P 3000499 [25029]



490P

2x4.25 Quick-slide filter plate holder
Ideal for tight work environments.

490P 3000509 [25062]



700 SERIES



The Huntsman 700 series welding helmets feature a lightweight, heat-resistant vulcanized fiber shell designed for use in acetylene welding and cutting applications. 711P features an aluminum frame filter plate holder - ideal for higher heat applications
Shipped without filter plates.

711P -2"x4.25" 3000503 [25048]
751P-4.25"x5.25" 3000516 [25071]



PROTECT YOUR GEAR! WELDING HELMET BAG

Made of heavy-duty denier fabric with drawstring closure. Features velcro close front lens pocket and two side mesh tool pockets. Throw the bag over your shoulder when you are ready to go! Fits all Jackson Safety helmets.

WELDING HELMET BAG 3010811

187-S MOUNTING BLADES



Securely attaches a welding helmet safely to safety cap. Positive locking device keeps the helmet in any position.

187-S MOUNTING KIT 3002634

187-S MOUNTING BLADES CAN BE USED WITH:

| | SC6 | SENTRY | CHARGER | SC16 | SB6-STUBBY |
|----------------------|-----|--------|---------|------|------------|
| HLX SERIES HALO X | ✓ | ✓ | ✓ | ✓ | ✓ |
| HSL SERIES SHADOW | ✓ | ✓ | ✓ | ✓ | ✓ |

187-K MOUNTING BLADES



Securely attaches a welding helmet safely to safety cap. Positive locking device keeps the helmet in any position.

187-S MOUNTING KIT 3002634

187-K MOUNTING BLADES CAN BE USED WITH:

| | SC6 | SENTRY | CHARGER | SC16 | SB6-STUBBY |
|----------|-----|--------|---------|------|------------|
| H SERIES | ✓ | ✓ | ✓ | | ✓ |

ROTO-CLIP



Lets you attach almost any Huntsman welding helmet safely and securely to a hard hat. Positive locking device keeps the helmet in any position.

1906 JACKSON CAPS 3000629
1908 4 PT SUS 3000631

ROTO-CLIP MOUNTING BLADES CAN BE USED WITH:

| | SC6 | SENTRY | CHARGER | SC16 | SB6-STUBBY |
|---------------------|-----|--------|---------|------|------------|
| 900 & 400 SERIES | ✓ | | ✓ | ✓ | ✓ |

87 MOUNTING BLADES



Attaches to almost any H series welding helmet safely and securely to a hard hat. Must use with 86 quick detach pins (not included), available in metal and plastic.

| | | |
|--------------------|---------|-------------|
| 87 MOUNTING BLADES | 3002435 | [0741-0061] |
| 86-M METAL PINS | 3002462 | [0743-9998] |
| 86 PLASTIC PINS | 3002453 | [0743-0007] |

87 MOUNTING BLADES & 86 PINS CAN BE USED WITH:

| | | | | | |
|----------|-----|--------|---------|------|------------|
| | SC6 | SENTRY | CHARGER | SC16 | SB6-STUBBY |
| H SERIES | | | | ✓ | |

386 CAPMOUNT ADAPTER



Lets you attach any H series fiberglass or HSL welding helmet safely and securely to a hard hat.

| | | |
|----------------------|---------|-------------|
| 386 CAPMOUNT ADAPTER | 3002645 | [0745-0027] |
|----------------------|---------|-------------|

386 CAPMOUNT ADAPTER CAN BE USED WITH:

| | | | | | |
|----------|-----|--------|---------|-----|------------|
| | SC6 | SENTRY | CHARGER | SC3 | SB6-STUBBY |
| H SERIES | | | | ✓ | |

*Can we used on most non-slotted safety caps

4000 UNIMATE



Attaches the 400 series welding helmet to most safety caps without slots. Quick and easy release.

| | | |
|--------------|---------|---------|
| 4000 UNIMATE | 3000577 | [30058] |
|--------------|---------|---------|

4000 UNIMATE CAN BE USED WITH:

| | | | | | |
|------------|-----|--------|---------|-----|------------|
| | SC6 | SENTRY | CHARGER | SC3 | SB6-STUBBY |
| 400 SERIES | | | | ✓ | |

*Can we used on most non-slotted safety caps

FILTER SELECTION GUIDE

Jackson Safety has a large selection of top-quality polycarbonate lenses for welding helmets and cutting goggles. To prevent surface damage to welding filter plates and auto darkening lenses, clear safety plates should always be inserted in front for protection. For your protection and comfort, be sure to use the correct filter shade for the job. Refer to the suggested shade guide.

GUIDE FOR SHADE NUMBERS (ADAPTED FROM ANSI TABLE Z89.1)

| OPERATION | ELECTRODE SIZE 1/32 IN. (MM) | ARC CURRENT (A) | SUGGESTED SHADE NO. (COMFORT) |
|--|------------------------------|-----------------|-------------------------------|
| Shielded metal arc welding | Less than 3 (2.5) | Less than 60 | 9 |
| | 3-5 (2.5-4) | 60-160 | 10 |
| | 5-8 (4-6,4) | 160-350 | 12 |
| | More than 8 (6,4) | 250-500 | 14 |
| Gas metal arc welding and flux cored arc welding | | Less than 60 | 9 |
| | | 60-160 | 11 |
| | | 160-350 | 12 |
| | | 250-500 | 14 |
| Gas tungsten arc welding | | Less than 50 | 10 |
| | | 50-150 | 12 |
| Air carbon Arc cutting | (light) | 150-500 | 14 |
| | (heavy) | Less than 500 | 12 |
| | (heavy) | 500-1000 | 14 |
| Plasma arc welding | | Less than 20 | 6 to 8 |
| | | 20-100 | 10 |
| | | 100-400 | 12 |
| | | 400-800 | 14 |
| Plasma Arc cutting | (light) | Less than 300 | 9 |
| | (medium) | 300-400 | 12 |
| | (heavy) | 400-800 | 14 |

FILTER LENS

| PART # | | DESCRIPTION | SIZE | MATERIAL |
|---------|---------|-------------------------|--------------|---------------|
| 3000691 | [40173] | 427 FILTER LENS SH. 5 | 2" X 4.25" | POLYCARBONATE |
| 3000644 | [40035] | 427 FILTER LENS SH. 9 | 2" X 4.25" | POLYCARBONATE |
| 3000645 | [40037] | 427 FILTER LENS SH. 10 | 2" X 4.25" | POLYCARBONATE |
| 3000690 | [40171] | 427 FILTER LENS SH. 11 | 2" X 4.25" | POLYCARBONATE |
| 3000646 | [40041] | 427 FILTER LENS SH. 12 | 2" X 4.25" | POLYCARBONATE |
| 3000649 | [40058] | 1127 FILTER LENS SH. 9 | 4.5" X 5.25" | POLYCARBONATE |
| 3000650 | [40059] | 1127 FILTER LENS SH. 10 | 4.5" X 5.25" | POLYCARBONATE |
| 3000651 | [40060] | 1127 FILTER LENS SH. 11 | 4.5" X 5.25" | POLYCARBONATE |
| 3000652 | [40061] | 1127 FILTER LENS SH. 12 | 4.5" X 5.25" | POLYCARBONATE |
| 3000684 | [40156] | 1227 FILTER LENS SH. 4 | 50 MM ROUND | POLYCARBONATE |
| 3000685 | [40157] | 1227 FILTER LENS SH. 5 | 50 MM ROUND | POLYCARBONATE |
| 3000686 | [40158] | 1227 FILTER LENS SH. 6 | 50 MM ROUND | POLYCARBONATE |

SAFETY PLATES/COVER LENS

| PART # | | DESCRIPTION | SIZE | MATERIAL | TYPE |
|---------|-------------|-----------------------------|----------------------|-----------------------|--------------|
| 3015039 | | BOSS BACK COVER LENS | | POLYCARBONATE | COVER LENS |
| 3015038 | | 90110 PC FRONT SAFETY PLATE | 90 X 110 | POLYCARBONATE | SAFETY PLATE |
| 3016169 | | 24 PC SAFETY PLATE | 2" X 4.25" | POLYCARBONATE | SAFETY PLATE |
| 3000658 | [40089] | 339 COVER LENS | 2" X 4.25" | THERMALLY SET PLASTIC | COVER LENS |
| 3000660 | [40093] | 339-L COVER LENS | 4.5" X 5.25" | THERMALLY SET PLASTIC | COVER LENS |
| 3002739 | [0752-0054] | NEXGEN BACK COVER LENS | | POLYCARBONATE | COVER LENS |
| 3000638 | [40015] | 235-6 COVER LENS | 4.5" X 5.25" X .060" | POLYCARBONATE | SAFETY PLATE |
| 3000689 | [40168] | 435-6 COVER LENS | 2" X 4.25" X .060" | POLYCARBONATE | SAFETY PLATE |
| 3002760 | [0752-0161] | 97-PC SAFETY PLATE | 4.5" X 5.25" | POLYCARBONATE | SAFETY PLATE |
| 3002759 | [0752-0151] | 54-PC SAFETY PLATE | 2" X 4.25" | POLYCARBONATE | SAFETY PLATE |
| 3002740 | [0752-0055] | 335-6 SAFETY PLATE/67 EXEC | EXECUTIVE | POLYCARBONATE | COVER LENS |

MAGNIFYING PLATES

Jackson Safety has an array of "Mag" plates to fit the needs of any welder. While providing close vision without glasses, the 2x4 mag plates are also adaptable to all EQC Filters. Select focal power by comparing prescription lenses.

| PART # | | FOCAL POWER | MAG PLATE ADAPTER KITS |
|---------|-------------|-------------|---|
| 3002741 | [0752-0063] | 1.00 | 3002656 [0745-0040] 98-2 EXECUTIVE EQC MAG LENS HOLDER |
| 3002742 | [0752-0064] | 1.25 | 3002647 [0745-0029] 98-3 LARGE WINDOW MAG LENS HOLDER (FOR HSL-100) |
| 3002743 | [0752-0065] | 1.50 | |
| 3002744 | [0752-0066] | 1.75 | |
| 3002745 | [0752-0067] | 2.00 | |
| 3002746 | [0752-0068] | 2.25 | |
| 3002747 | [0752-0069] | 2.50 | |

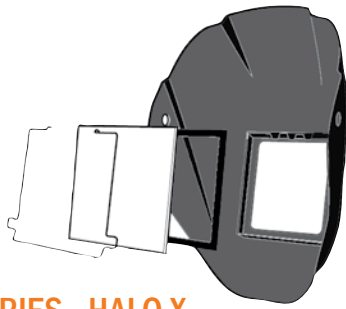

HLX SERIES - HALO X

DESCRIPTION

- A. 853 RETAINER SPRING
- B. 1127 FILTER LENS SHADE 10
- C. 97-PC SAFETY PLATE
- D. 251 LIGHT SEAL

| PART # | |
|---------|-------------|
| 3002648 | [0745-0031] |
| 3000650 | [40059] |
| 3002760 | [0752-0161] |
| 3004736 | [0745-0045] |

NOT SHOWN:

| | | |
|----------------|---------|-------------|
| 270-S HEADGEAR | 3002669 | [0745-0036] |
|----------------|---------|-------------|

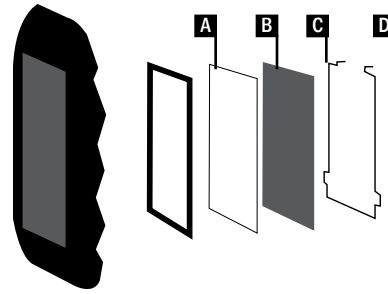

SHADOW® HSL 100

DESCRIPTION

- A. 251 LIGHT SEAL GASKET
- B. 97-PC SAFETY PLATE
- C. 1127 FILTER LENS SHADE 10
- D. 853 RETAINER SPRING

| PART # | |
|---------|-------------|
| 3004736 | [0745-0045] |
| 3002760 | [0752-0161] |
| 3000650 | [0752-0082] |
| 3002648 | [0745-0031] |

NOT SHOWN:

| | | |
|----------------|---------|-------------|
| 270-S HEADGEAR | 3002669 | [0745-0036] |
|----------------|---------|-------------|

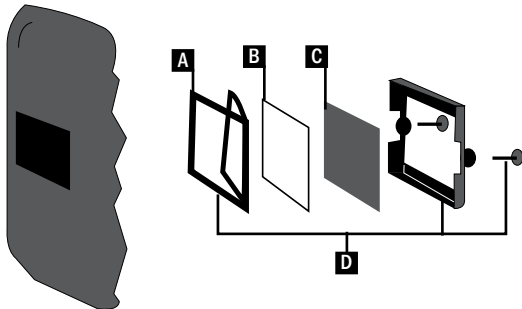

SHADOW® HSL 1

DESCRIPTION

- A. 224 LIGHT SEAL GASKET
- B. 54-PC SAFETY PLATE
- C. 427 FILTER LENS SHADE 10
- D. LENS RETAINER KIT

| PART # | |
|---------|-------------|
| 3002653 | [0745-0036] |
| 3002759 | [0752-0151] |
| 3000645 | [40037] |
| 3002641 | [0745-0017] |

NOT SHOWN:

| | | |
|----------------|---------|-------------|
| 270-S HEADGEAR | 3002669 | [0745-0036] |
|----------------|---------|-------------|

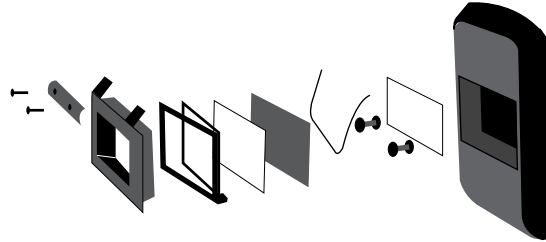

SHADOW® HSL 2

DESCRIPTION

- A. 224 LIGHT SEAL GASKET
- B. 54-PC SAFETY PLATE
- C. 427 FILTER LENS SHADE 10
- D. 63 RETAINER SPRING
- E. 54-PC SAFETY PLATE
- F. HSL 2 LIFT FRONT KIT

| PART # | |
|---------|-------------|
| 3002653 | [0745-0036] |
| 3002759 | [0752-0151] |
| 3000645 | [40037] |
| 3002640 | [0745-0013] |
| 3002759 | [0752-0151] |
| 3002642 | [0745-0018] |

NOT SHOWN:

| | | |
|----------------|---------|-------------|
| 270-S HEADGEAR | 3002669 | [0745-0036] |
|----------------|---------|-------------|

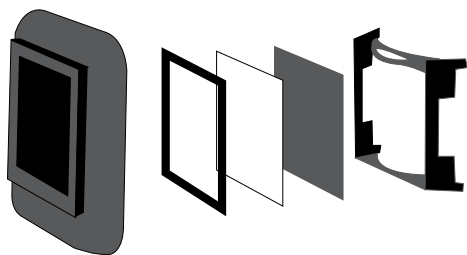

H100-A & H-500

DESCRIPTION

- A. 251 LIGHT SEAL GASKET
- B. 97-PC SAFETY PLATE
- C. 427 FILTER LENS SHADE 10
- D. 220-P LARGE LENS SPRING

| PART # | |
|---------|-------------|
| 3004736 | [0745-0045] |
| 3002760 | [0752-0161] |
| 3000645 | [40037] |
| 3002639 | [0745-0010] |

NOT SHOWN:

| | | |
|--------------|---------|-------------|
| 170 HEADGEAR | 3002454 | [0743-0010] |
|--------------|---------|-------------|

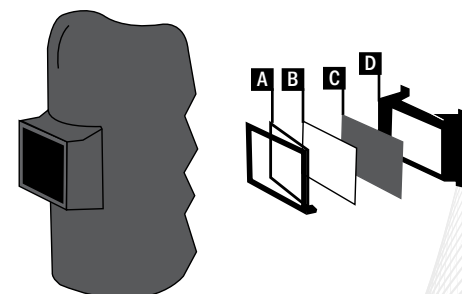

HM1-A & HM-5 HANDSHIELD

DESCRIPTION

- A. 224 LIGHT SEAL GASKET
- B. 54-PC SAFETY PLATE
- C. 427 FILTER LENS SHADE 10
- D. 258 LENS SPRING

| PART # | |
|---------|-------------|
| 3002653 | [0745-0036] |
| 3002759 | [0752-0151] |
| 3000645 | [40037] |
| 3002638 | [0745-0009] |

NOT SHOWN:

| | | |
|--------------|---------|-------------|
| 170 HEADGEAR | 3002454 | [0743-0010] |
|--------------|---------|-------------|

PARTS GUIDE

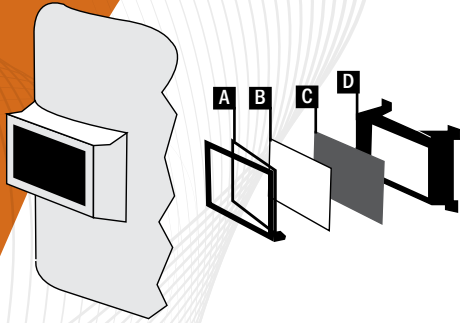

HM1-PW PIPE LINE STYLE

| DESCRIPTION | PART # | |
|-----------------------------|---------|-------------|
| A. 224 LIGHT SEAL GASKET | 3002653 | [0745-0036] |
| B. 54-PC SAFETY PLATE | 3002759 | [0752-0151] |
| C. 427 FILTER LENS SHADE 10 | 3000645 | [40037] |
| D. 258 LENS SPRING | 3002638 | [0745-0009] |
| NOT SHOWN: | | |
| 170-P HEADGEAR | 3002661 | [0745-0047] |

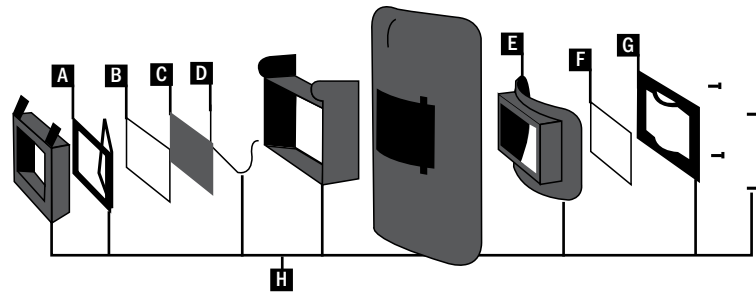

H9-A, H2-A, H4-A, & HR-2A

| DESCRIPTION | PART # | |
|-----------------------------|---------|-------------|
| A. 224 LIGHT SEAL GASKET | 3002653 | [0745-0036] |
| B. 54-PC SAFETY PLATE | 3002759 | [0752-0151] |
| C. 427 FILTER LENS SHADE 10 | 3000645 | [40037] |
| D. 63 RETAINER SPRING | 3002640 | [0745-0013] |
| E. 66-7 INNER LENS RETAINER | 3002651 | [0745-0034] |
| F. 54-PC SAFETY PLATE | 3002759 | [0752-0151] |
| G. 58 RETAINER SPRING | 3002636 | [0745-0006] |
| H. 66 LIFT-FRONT UNIT | 3002635 | [0745-0005] |
| NOT SHOWN: | | |
| 170 HEADGEAR | 3002454 | [0743-0010] |



930P, 860-2 & 430P

| DESCRIPTION | PART # | |
|-----------------------------|---------|-------------|
| A. 4158-1 BACK PLATE | 3000620 | [35082] |
| B. 441 SPRING GASKET | 3000601 | [35040] |
| C. 421 FIBRE GASKET | 3000596 | [35031] |
| D. 54-PC SAFETY PLATE | 3002759 | [0752-0151] |
| E. 433P RETAINING SPRING | 3000610 | [35067] |
| F. 54-PC SAFETY PLATE | 3002759 | [0752-0151] |
| G. 427 FILTER LENS SHADE 10 | 3000645 | [40037] |
| H. 421 FIBRE GASKET | 3000596 | [35031] |
| I. 54-PC SAFETY PLATE | 3002759 | [0752-0151] |
| J. 434-1 LIFT FRONT | 3000598 | [35034] |
| NOT SHOWN: | | |
| 170 HEADGEAR | 3002454 | [35083] |

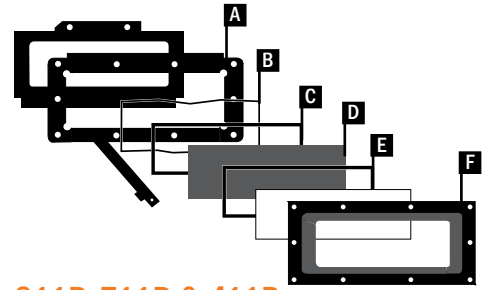

911P, 711P & 411P

| DESCRIPTION | PART # | |
|-------------------------------|---------|-------------|
| A. 4158-1 BACK PLATE | 3000620 | [35082] |
| B. 441 SPRING GASKET | 3000601 | [35031] |
| C. 421 FIBRE GASKET | 3000596 | [35040] |
| D. 54-PC SAFETY PLATE | 3002759 | [0752-0151] |
| E. 421 FIBRE GASKET | 3000596 | [35040] |
| F. 415-1 ALUMINUM GLASSHOLDER | 3000623 | [35085] |
| NOT SHOWN: | | |
| 170 HEADGEAR | 3002454 | [35083] |

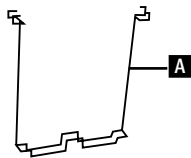

951P

| DESCRIPTION | PART # | |
|--------------------------|---------|---------|
| A. 444-2 RETAINER SPRING | 3000615 | [35073] |
| B. 445-1 & 1A GASKET SET | 3000614 | [35072] |
| NOT SHOWN: | | |
| 170 HEADGEAR | 3002454 | [35083] |

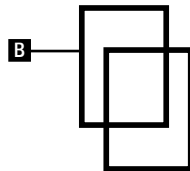

981P

| DESCRIPTION | PART # | |
|-------------------------------|---------|---------|
| A. 433A RETAINING SPRING | 3000610 | [35067] |
| B. 421-1 & 1A PLASTIC GASKETS | 3000613 | [35071] |
| NOT SHOWN: | | |
| 170 HEADGEAR | 3002454 | [35083] |

weldingsafety



PARTS GUIDE

990P & 490P QUICK-SLIDE

| DESCRIPTION | PART # | |
|--------------------------------|---------|-------------|
| A. 415A FRONT PLATE | 3000595 | [35028] |
| B. 54-PC SAFETY PLATE | 3002759 | [0752-0151] |
| C. 421 FIBRE GASKET | 3000596 | [35031] |
| D. 452 ALUMINUM BACK PLATE | 3000609 | [35062] |
| E. 449 PLASTIC BACK PLATE | 3000605 | [35058] |
| F. 450 GLASS RET CLIP FOR 490P | 3000606 | [35059] |
| G. 427 FILTER LENS SHADE 10 | 3000645 | [0752-0151] |
| H. 451A TENSION PLATE | 3000607 | [35060] |

| NOT SHOWN: | | |
|--------------------------|---------|---------|
| 170 HEADGEAR | 3002454 | [35083] |
| 447 QUICK-SLIDE ASSEMBLY | 3000603 | [35055] |
| 448 PLASTIC SLIDE GUIDE | 3000604 | [35057] |

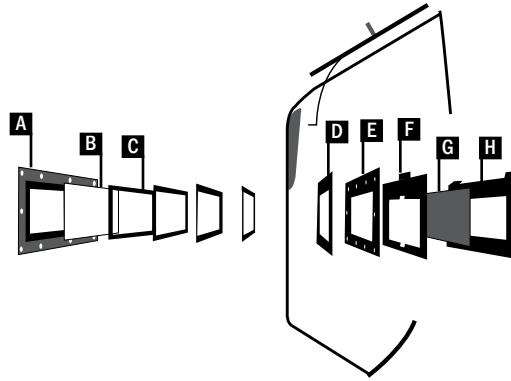
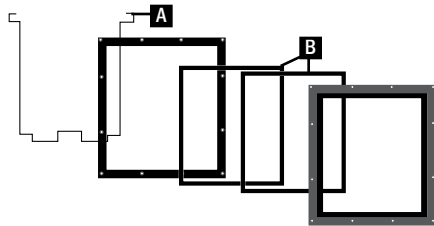

451P & 751P

| DESCRIPTION | PART # | |
|--------------------------|---------|---------|
| A. 444-2 RETAINER SPRING | 3000615 | [35073] |
| B. 445-1 & 1A GASKET SET | 3000614 | [35072] |

| NOT SHOWN: | | |
|--------------|---------|---------|
| 170 HEADGEAR | 3002454 | [35083] |

860P

| DESCRIPTION | PART # | |
|-----------------------------|---------|-------------|
| A. 434C BACK COVER PLATE | 3000600 | [35036] |
| B. 433A RETAINING SPRING | 3000610 | [35067] |
| C. 421 FIBRE GASKET | 3000596 | [35031] |
| D. 54-PC SAFETY PLATE | 3002759 | [0752-0151] |
| E. 433A RETAINING SPRING | 3000610 | [35067] |
| F. 54-PC SAFETY PLATE | 3002759 | [0752-0151] |
| G. 427 FILTER LENS SHADE 10 | 3000645 | [40037] |
| H. 421 FIBRE GASKET | 3000596 | [35031] |
| I. 54-PC SAFETY PLATE | 3002759 | [0752-0151] |

| NOT SHOWN: | | |
|--------------|---------|---------|
| 170 HEADGEAR | 3002454 | [35083] |

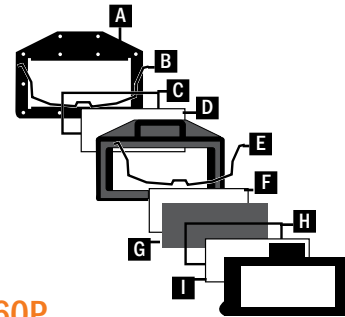

REPLACEMENT HEADGEAR

270-S HEADGEAR



270-S features an ergonomically designed, streamlined ratchet for easy adjustments and increased shell clearance. Six crown adjustments with comfortable strap and absorbent sweatband. For use with Shadow, Halo X and HML series helmets produced after May 2000.

| DESCRIPTION | PART # | |
|----------------|---------|-------------|
| 270-S HEADGEAR | 3002669 | [0745-0073] |

170 HEADGEAR



170 features 45 head size adjustments and 5 crown adjustments. Lower ratchet strap for added comfort and strength. Ratchet eliminates "backing off" with push and turn design. For use with H series fiberglass helmets, [excluding HSL series.]

| DESCRIPTION | PART # | |
|--------------|---------|-------------|
| 170 HEADGEAR | 3002454 | [0743-0010] |

117A HEADGEAR



Plastic headgear fits all Huntsman helmets. Teeth are automatically disengaged during adjustment. Air cushioned cloth sweatband is washable and durable.

| DESCRIPTION | PART NO | |
|---------------|---------|---------|
| 117A HEADGEAR | 3000621 | [35083] |

170-P HEADGEAR



170-P features 45 head size adjustments and 5 crown adjustment. Rubber strap sits across the back of the head. For use with HM1-PW pipe line style helmet only.

| DESCRIPTION | PART # | |
|-------------|---------|-------------|
| 170-P | 3002661 | [0745-0047] |

WILDCAT™ CUTTING GOGGLES



Extreme performance vision protection. Lightweight and comfortable with a pivoting headband that allows custom fit. Adjustable side vents ensure increased air flow. Material does not melt, drip, or ignite at 350°F for five minutes. Anti-fog lenses. Meets NFPA 1977 standards. Standard Pack: 12

| DESCRIPTION | PART # |
|-------------------|----------|
| IRUV 3.0 ANTI-FOG | 3013713* |
| IRUV 5.0 ANTI-FOG | 3013714* |

THE SHIELD™ CUTTING GOGGLES



Features the Monogoggle® XTR goggle with a polycarbonate shield for full face protection. Shield detaches from the goggle. Curved faceshield conforms to shape of face offering better protection. Indentations in face seal to fit over most prescription glasses. Flame retardant headband. IRUV goggle lens with dark green shield. Standard Pack: 6



| DESCRIPTION | PART # |
|-----------------------------|---------|
| THE SHIELD, IRUV 3.0 AF | 3010345 |
| THE SHIELD, IRUV 5.0 AF | 3010346 |
| MONOGOGGLE XTR, IRUV 3.0 AF | 3010337 |
| MONOGOGGLE XTR, IRUV 5.0 AF | 3010338 |

Shown in image: #3008175- OTG IRUV 5.0



IRUV FACESHIELDS FOR CUTTING / GRINDING

Ideal for cutting, grinding or chipping, these polycarbonate faceshields attach easily to safety caps or can be used with a stand alone headgear.

| DESCRIPTION | SIZE | PART # |
|----------------|--------------------|---------------------|
| 34-63 IRUV 3.0 | 15.5" X 8" X .060" | 3002813 [0754-0034] |
| 34-65 IRUV 5.0 | 15.5" X 8" X .060" | 3002810 [0754-0031] |



Shown in image: #3002436 - 170SB Headgear

CUTTING & GRINDING EYEWEAR



OTG™
Stylish over-the-glass design that fits over most prescription eyewear. Standard Pack: 12

| FRAME/LENS | PART # |
|----------------|---------|
| BLACK/IRUV 5.0 | 3018175 |



30-06™ READERS
Features a precisely placed diopter for easy magnifying during use. Standard Pack: 12

| FRAME/LENS | PART # |
|---------------------|---------|
| BLACK/IRUV 5.0 +1.5 | 3013933 |
| BLACK/IRUV 5.0 +2.0 | 3013968 |
| BLACK/IRUV 5.0 +2.5 | 3013969 |



NEMESIS™
Sleek, sporty design with soft touch temples for added comfort. Standard Pack: 12

| FRAME/LENS | PART # |
|----------------|-----------------|
| BLACK/IRUV 3.0 | 3004762 [19859] |
| BLACK/IRUV 5.0 | 3004761 [19860] |

weldingsafety



2" X 4.25" CUTTING GOGGLES



WS SERIES

Flexible frame with shade 5.0 lens and an adjustable elastic strap. Available in a fixed or lift front design.
Standard Pack: 24

| DESCRIPTION | PART # |
|-------------------|----------------------|
| WS-80 FIXED FRONT | 3002695* [0746-0505] |
| WS-85 LIFT FRONT | 3002696* [0746-0515] |



WR SERIES

Rigid frame with shade 5.0 fixed front and adjustable elastic strap. Also available in a deep frame to fit over most prescription glasses.
Standard Pack: 24

| DESCRIPTION | PART # |
|-------------------|----------------------|
| WR-60 | 3002687 [0746-0223] |
| WR-600 DEEP FRAME | 3002688* [0746-0235] |



WA SERIES

Rigid frame with shade 5.0 fixed front. Features adjust-o-lock™ headgear. Also available in a deep frame to fit over most prescription glasses.
Standard Pack: 12

| DESCRIPTION | PART # |
|-------------------|---------------------|
| WA-60 | 3002689 [0746-0315] |
| WA-600 DEEP FRAME | 3002690 [0746-0325] |

50MM ROUND CUTTING GOGGLES



WR-70

Rigid frame with shade 5.0, 50mm round lens. Features an adjustable elastic strap.
Standard Pack: 24

| DESCRIPTION | PART # |
|-------------|---------------------|
| WR-70 | 3002686 [0746-0209] |



WR-40

Rigid eye cup style with shade 5.0, 50 mm round lens. Features an adjustable elastic strap.
Standard Pack: 24

| DESCRIPTION | PART # |
|-------------|---------------------|
| WR-40 | 3002681 [0746-0103] |



JP-150

Flexible frame with shade 5.0, 50 mm round lens. Features an adjustable elastic strap.
Standard Pack: 24

| DESCRIPTION | PART # |
|-------------|---------------------|
| JP-150 | 3002684 [0746-0125] |



NEMESIS VL™

Frameless ultra-lightweight design increases upward & peripheral vision.
Standard Pack: 12

| FRAME/LENS | PART # |
|----------------|---------|
| BLACK/IRUV 5.0 | 3013544 |



HELLRAISER™

Extreme lightweight design with flex point temples for comfort & stability.
Standard Pack: 12

| FRAME/LENS | PART # |
|----------------|---------|
| BLACK/IRUV 3.0 | 3013859 |
| BLACK/IRUV 5.0 | 3013860 |



MAGNUM® 3G Smith & Wesson

Ergonomic self-adjusting rubber nose pad & fingers for added comfort.
Standard Pack: 12

| FRAME/LENS | PART # |
|----------------|---------|
| BLACK/IRUV 3.0 | 3011668 |
| BLACK/IRUV 5.0 | 3011669 |

JACKSON SAFETY ELECTRODE HOLDERS

Units feature integrated slots for convenient angled holding, fully insulated pivots and springs for maximum dielectric integrity. Large dome screw cable connectors are designed for near unbreakable connection and copper wrap to ensure maximum conductivity. Integral grooves allow for efficient heat dissipation and extended handle with integral ribs that act as a cable support system, eliminating play, reducing wear. Available in heavy duty copper or aluminum alloy.

JH-1 & JH-2 ELECTRODE HOLDER



JH-1: Features 3/16" electrode capacity and 50% duty cycle rating. Rated 250 Amperes with No. 4 through 1/0 cable capacity. Lightweight design - only 12 oz.

JH-1 HOLDER

3001793 [0700-0011]

JH-2: Features 5/32" electrode capacity with 45% duty cycle rating. Rated for 200 Amperes with No.4 through 1/0 cable capacity. Aluminium alloy construction and lightweight 10 oz. design.

JH-2 HOLDER

3001797 [0700-0022]

AW-C & A-W ELECTRODE HOLDER



AW-C: Features 1/4" electrode capacity and 45% duty cycle rating. Rated for 300 Amperes with No. 2 through 2/0 cable capacity. Aluminum alloy construction. Weighs 19 oz.

AW-C HOLDER

3001794 [0700-0012]

A-W: Features 1/4" electrode capacity and 45% duty cycle rating. Rated for 300 Amperes with No. 2 through 2/0 cable capacity. Aluminum alloy construction. Weighs 14 oz.

A-W HOLDER

3001796 [0700-0019]

A3-S ELECTRODE HOLDER



A3-S: Features 3/8" electrode capacity with 60% duty cycle rating. Rated 500 Amperes with 2/0 through 4/0 cable capacity. Copper alloy construction. Weighs 30 oz.

A3-S HOLDER

3001795 [0700-0016]

J-4 ELECTRODE HOLDER



J-4: Features 1/4" electrode capacity with 60% duty cycle rating. Rated 400 Amperes with No. 2 through 1/0 cable capacity. Handle size adjusts to electrode sizes with 45 degree head angle. Weighs 16 oz.

J-4 HOLDER

3001798 [0700-0034]

JACKSON SAFETY GROUND CLAMPS

Forged copper alloy ground clamps have higher conductivity, fewer resistances, and run at a cooler temperature at higher Amps for better arc starting. The extra-large contact areas provide superior conductivity and higher clamping pressure, and the long-lever, finger-grip contoured handle allows for easy jaw opening.

GROUND CLAMPS



GC-2: 200 Amperes rating with 1-1/4" jaw capacity. No. 4 through 1/0 cable capacity. Weighs 16 oz.

GC-3: 300 Amperes rating with 1-5/8" jaw capacity. 1/0 and 2/0 cable capacity. Weighs 23 oz.

GC-5: 500 Amperes with 2" jaw capacity. 3/0 and 4/0 cable capacity. Weighs 34 oz.

| | | |
|------------|---------|-------------|
| GC-2 CLAMP | 3001834 | [0702-0001] |
| GC-3 CLAMP | 3001835 | [0702-0002] |
| GC-5 CLAMP | 3001836 | [0702-0003] |

ELECTRODE/CABLE SIZE GUIDE

| A.W.G. Size Copper Welding Cable | Diameter over bare conductor | * Recommended Max. Amperage | ** Normal Max. Electrode Size |
|----------------------------------|------------------------------|-----------------------------|-------------------------------|
| No. 6 | .210" | 85 | 3/32" |
| No. 4 | .275" | 150 | 1/8" |
| No. 2 | .335" | 200 | 5/32" |
| No. 1 | .400" | 250 | 5/32" - 3/16" |
| 1/0 | .440" | 300 | 3/16" - 7/32" |
| 2/0 | .490" | 375 | 7/32" - 1/4" |
| 3/0 | .545" | 450 | 1/4" - 5/16" |
| 4/0 | .635" | 550 | 5/16" - 3/8" |

* Recommended Maximum Amperage is based on normal shop conditions for manual welding with its approximate 40 to 50% duty cycle (arc time). On automatic welding where the duty cycle is high it is recommended that one size larger cable be used.

** Normal Maximum Electrode Size recommendation varies with the wide permissible amperage range with iron powder electrodes. If electrodes are to be used at the outer range for peak deposition rates it is advisable to increase cable by one size.

CROSS REFERENCE CHARTS

ELECTRODE HOLDERS

| Jackson | Tweco | Lenco |
|---------|---------|--------|
| JH-1 | A-316 | AF-2 |
| JH-2 | N/A | N/A |
| A-W | N/A | N/A |
| AW-C | A-732 | AF-3 |
| J-4 | 4-TT | TT-4-B |
| A3-S | A-38-HD | AF-50 |

GROUND CLAMPS

| Jackson | Tweco | Lenco |
|---------|---------|-------|
| GC-2 | FGC-200 | 200 |
| GC-3 | FGC-300 | 300 |
| GC-5 | FGC-500 | 500 |

CABLE CONNECTORS

| Jackson | Tweco | Lenco |
|---------|----------------|---------|
| UB-1-BP | 1-MBP or 1-MPC | LC-10 |
| UB-3-BP | 2-MBP or 2-MPC | LC-40 |
| UB-4-BP | 4-MBP or 4-MPC | LC-40HD |

*DUTY CYCLE RATING IS THE MAXIMUM PERCENTAGE OF ARC TIME (OUT OF ANY 10-MINUTE PERIOD) THAT A HOLDER SHOULD BE EXPECTED TO PERFORM COMFORTABLY.

UNI-TRIK® CABLE CONNECTORS

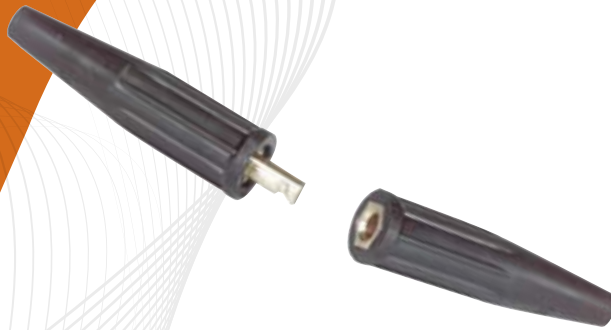

UNI-TRIK® cable connectors are completely insulated, with no exposed metal and feature large, dome-nose cable screws to ensure a virtually unbreakable, high conductivity connection. A form fitting rubber outer jacket prevents screws from shorting out and tapered ends lock out moisture, oil and dirt.

- UB-1-BP: For cables No. 4 through No. 1
- UB-3-BP: For cables 1/0 through 3/0
- UB-4-BP: For cables 3/0 through 4/0

| | |
|---------|---------------------|
| UB-1-BP | 3001848 [0704-0020] |
| UB-3-BP | 3001849 [0704-0210] |
| UB-4-BP | 3001852 [0704-0213] |

QUIK-TRIK® CABLE CONNECTORS



QUIK-TRIK® top-of-the-line cable connector halves have morse-tapered sections that are drawn together with a cam and locking bar, for maximum conductivity. Tapered ends that cover the cable jacket and lock out moisture, oil and dirt.

- QNB-2-BP: For cables 1/0 and 2/0
- QNB-4-BP: For cables 3/0 and 4/0
- QB-2-BP: For cables 1/0 and 2/0

| | |
|----------|---------------------|
| QNB-2-BP | 3001840 [0704-0001] |
| QNB-4-BP | 3001841 [0704-0202] |
| QB-2-BP | 3001842 [0704-0204] |

INSULATED CABLE LUGS



Cable lugs give you completely insulated welding machine terminal connections, plus quick-connect convenience. Sold in pairs.

| | |
|----------------------|---------------------|
| QLB-45 QUIK-TRIK LUG | 3001855 [0706-0034] |
| ULB-45 UNI-TRIK LUG | 3001854 [0706-0030] |

TERMINAL COVERS



The easiest, least costly way to protect against electrical shock from exposed welding machine terminal connections. Sold in pairs.

| | |
|-----------------|---------------------|
| TERMINAL COVERS | 3001853 [0706-0029] |
|-----------------|---------------------|

ELECTRIC LINE: PARTS GUIDES

JH-1 HOLDER

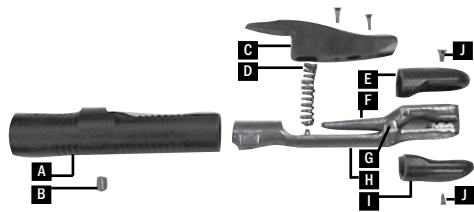

| DESCRIPTION | PART # | |
|---|---------|-------------|
| A. 1306 HANDLE | 3001830 | [0701-0071] |
| B. 2302 HANDLE SCREW | 3004753 | [0701-0073] |
| C. 206 LEVER | 3001825 | [0701-0063] |
| D. 1006 SPRING | 3001812 | [0701-0044] |
| E. 103 INSULATOR | 3001815 | [0701-0050] |
| F. 514 UPPER TONG | 3001803 | [0701-0009] |
| G. 619 LOWER TONG | 3001804 | [0701-0018] |
| H. 1503 INSULATOR SCREW | 3001822 | [0701-0059] |
| NOT SHOWN: | | |
| 1617 CABLE CLAMP KIT (INCLUDES COPPER WRAP & 2 SET SCREWS) | 3001832 | [0701-0074] |

JH-2 HOLDER

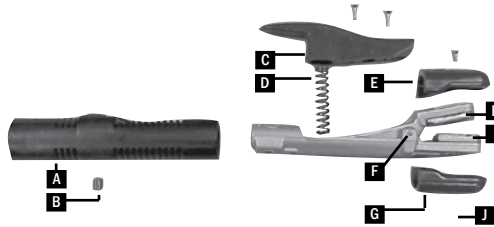

| DESCRIPTION | PART # | |
|---|---------|-------------|
| A. 1306 HANDLE | 3001830 | [0701-0071] |
| B. 2302 HANDLE SCREW | 3004753 | [0701-0073] |
| C. 206 LEVER | 3001825 | [0701-0063] |
| D. 1006 SPRING | 3001812 | [0701-0044] |
| E. 103 INSULATOR | 3001815 | [0701-0050] |
| F. 3106 TONG PIN | 3001807 | [0701-0034] |
| G. 103 INSULATOR | 3001815 | [0701-0050] |
| H. 1703 UPPER JAW | 3001809 | [0701-0039] |
| I. 1803 LOWER JAW | 3001810 | [0701-0040] |
| J. 1503 INSULATOR SCREW | 3001822 | [0701-0059] |
| NOT SHOWN: | | |
| 1616 CABLE CLAMP KIT (INCLUDES COPPER WRAP & 2 SET SCREWS) | 3001833 | [0701-0075] |

AW-C HOLDER

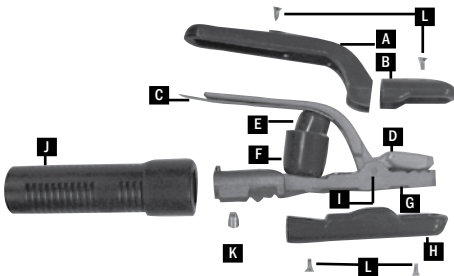

| DESCRIPTION | PART # | |
|---|---------|-------------|
| A. 203 INSULATOR LEVER | 3001817 | [0701-0053] |
| B. 103 INSULATOR | 3001815 | [0701-0050] |
| C. 904 INSULATOR STRIP | 3001823 | [0701-0061] |
| D. 513 UPPER TONG | 3001801 | [0701-0007] |
| E. 1101 SMALL SPRING CUP | 3001813 | [0701-0047] |
| F. 1201 LARGE SPRING CUP | 3001814 | [0701-0049] |
| G. 618 LOWER TONG | 3001805 | [0701-0019] |
| H. 403 INSULATOR LOWER NOSE | 3001820 | [0701-0057] |
| I. 3101 TONG PIN | 3001806 | [0701-0032] |
| J. 1301 HANDLE | 3001827 | [0701-0068] |
| K. 2302 HANDLE SCREW | 3004753 | [0701-0073] |
| I. 1503 INSULATOR SCREW | 3001822 | [0701-0059] |
| NOT SHOWN: | | |
| 1616 CABLE CLAMP KIT (INCLUDES COPPER WRAP & 2 SET SCREWS) | 3001833 | [0701-0075] |
| 1001 INNER SPRING | 3001811 | [0701-0043] |

AW HOLDER

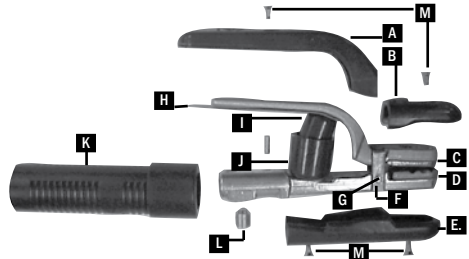

| DESCRIPTION | PART # | |
|---|---------|-------------|
| A. 203 INSULATOR LEVER | 3001817 | [0701-0053] |
| B. 103 INSULATOR | 3001815 | [0701-0050] |
| C. 1703 UPPER JAW | 3001809 | [0701-0039] |
| D. 1803 LOWER JAW | 3001810 | [0701-0040] |
| E. 403 INSULATOR | 3001820 | [0701-0057] |
| F. 3202 YOKE | 3001808 | [0701-0036] |
| G. 3101 TONG PIN | 3001806 | [0701-0032] |
| H. 904 INSULATOR, STRIP | 3001823 | [0701-0061] |
| I. 1101 SMALL SPRING CUP | 3001813 | [0701-0047] |
| J. 1201 LARGE SPRING CUP | 3001814 | [0701-0049] |
| K. 1301 HANDLE | 3001827 | [0701-0068] |
| I. 2302 HANDLE SCREW | 3004753 | [0701-0073] |
| M. 1503 INSULATOR SCREW | 3001822 | [0701-0059] |
| NOT SHOWN: | | |
| 1616 CABLE CLAMP KIT (INCLUDES COPPER WRAP & 2 SET SCREWS) | 3001833 | [0701-0075] |
| 1001 INNER SPRING | 3001811 | [0701-0043] |

A3-S HOLDER

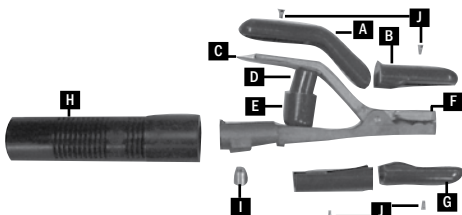

| DESCRIPTION | PART # | |
|---|---------|-------------|
| A. 201 INSULATOR LEVER | 3001818 | [0701-0054] |
| B. 102 UPPER NOSE | 3001816 | [0701-0051] |
| C. 903 INSULATOR STRIP | 3001824 | [0701-0062] |
| D. 1101 SMALL SPRING CUP | 3001813 | [0701-0047] |
| E. 1201 LARGE SPRING CUP | 3001814 | [0701-0049] |
| F. 501 UPPER TONG | 3001802 | [0701-0008] |
| G. 303 INSULATOR | 3001826 | [0701-0067] |
| H. 1305 HANDLE | 3001828 | [0701-0069] |
| I. 2302 HANDLE SCREW | 3004753 | [0701-0073] |
| J. 1503 INSULATOR SCREW | 3001822 | [0701-0059] |
| NOT SHOWN: | | |
| 1614 CABLE CLAMP KIT (INCLUDES COPPER WRAP & 2 SET SCREWS) | 3001829 | [0701-0070] |
| 1001 INNER SPRING | 3001811 | [0701-0043] |

CURV-O-MARK®

Curv-O-Mark® layout systems have earned a reputation for quality and consistency over a wide range of industries. Easy to use, long-lasting and durable tools, Curv-O-Mark® tools help bring precision to most any layout task.

CONTOUR WORKER KIT



Contour Worker Kit features the top selling precision pipe marking tools with a heavy-duty metal locking case for convenient storage. These tools are durable, long lasting and provide a timesaving solution to the precision marking applications. Kit includes:

- #1 Contour Marker
- #7 Centering Head
- #8 Pro Mag Level
- Standard Radius Marker
- Square Soap Stone & Holder
- Lockable metal carrying case

CONTOUR WORKER KIT

3014807

#1 CONTOUR MARKER



#1 Contour Marker is a compact design, time-saving tool used to lay out pipe and structural steel joints. Ideal for quick, precise layout of laterals at any angle, tees, wyes, crosses, elbows -- any type or size of joint (for use on same size pipe intersections). Eliminates complicated mathematical formulas, cut and try, and needless material waste. Can be used to lay out pipe from 1-1/2" to 18" diameter, or structural steel members up to 18" in a right side up or upside down position. Consists of an X-shaped frame, calibrated protractor, and a triple-jointed marking arm and holder. Protractor is calibrated on both sides -- one in degrees, the other in rise-inches-per-foot -- to service any type of measurement need. Holder accepts a soapstone crayon (included), felt pen or pencil.

#1 CONTOUR MARKER

3001874 [0721-0000]

contour

#4 JUMBO CONTOUR MARKER

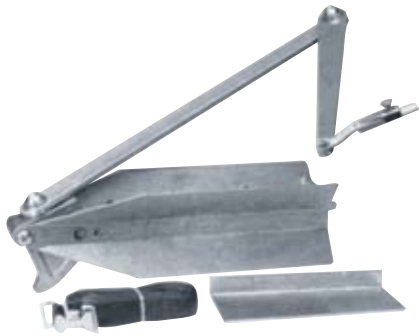

Developed for use in the layout of large diameter pipe, from 8" to 48" and structural seal joints, of the same size pipe. Comes complete with a durable web strap (included) to help hold the unit in place during layout. Built-in adjustable dial set level (DSL) ensures accurate center-line location. A soapstone crayon is included.

#4 JUMBO CONTOUR MARKER 3001877 [0721-0003]

COMBO ADAPTOR ACCESSORY



Designed for use with the Standard and Jumbo Contour Markers, the adaptor simplifies handling and increases layout flexibility. Permits use of all four sides of the Contour Marker and allows marking on small diameter pipe, over nipples, old weld or on wrapped pipe. Also provides layouts with compound angles Using a single setting, or any degree of take-off on elbows and turns up to 90°.

#2 STANDARD 3001875 [0721-0003]
#5 JUMBO 3001878 [0721-0004]

#14 CIRCLE ELLIPSE PROJECTOR



Ideal for creating perfect circles, ellipses or oblong circles on any irregular flat or round surface. Can be used to lay out lateral intersections of different diameter pipes, or to project circles from 1-1/2" to 18" diameter on flat surfaces intersecting at angles from 0 to 70° from vertical. Features a protractor with sliding rod and an adjustable lever to lock in the specified layout. Strong, 20-pound pull magnetic base holds the Projector in position during layout. Durable web strap (included) holds the unit secure on non-magnetic surfaces and can be used on either side of the vertical column. The Projector is equipped with a soapstone crayon and also works with chalk, pencil or steel scribe.

#14 CIRCLE ELLIPSE PROJECTOR 3001888 [0721-0014]

CENTERING HEAD



Aids in the setting of center lines, establishing angles and marks for butt-ins, locating points inside pipes and tanks, laying out keyways and measuring declivity. Standard Model is used on pipe 1/2" diameter and larger and has a 4" Y-type head fitted with an adjustable dial set level (DSL) and a manually operated hardened centering pin. Jumbo Centering Head is ideal for pipe 1" diameter and up and has an 8" Y-type head and a DSL. A spring-loaded hardened centering pin eliminates the need for a hammer.

#6 STANDARD 3001879 [0721-0005]
#7 JUMBO 3001880 [0721-0006]

#9 FITTER WELDER PROTRACTOR



90° protractor has a matching locking lever to set and hold the tool at the desired angle. Equipped with a 5.8" by 10" tapered arm to complete finding of angles or desired bends, or to determine any portions of elbows. Tool is mounted in a 3/4" wide frame with a 3/8" by 6" cast-in rod and comes with a 25-pound pull magnetic base for holding the protractor frame in position. Can be used manually or with a magnetic base.

#9 FITTER WELDER PROTRACTOR 3001882 [0721-0008]

#32 FLANGE ALIGNER BASE



Removes the difficulty of flange aligning and squaring. Tool holds a square in the needed position without tying up one's hands. Base is notched at either end for ease in aligning on the center line of the pipe. Two 25-pound pull, cast-in magnets for holding either a flat horizontal or vertical position. Base accepts either leg of a standard or combination aluminum square and works on pipe diameters from 1"+, requiring only the extension of the legs of the square being used to accommodate larger diameters.

#32 FLANGE ALIGNER BASE 3001903 [0721-0029]

#10 PIPE FLANGE ALIGNER



Aids in fast, accurate pipe construction with self-determining flange aligning tool. Inserts easily into pipe, centers snugly against the inside pipe diameter and automatically aligns with the pipe axis. Quickly adjustable for all types of flanges or pipe sizes ranging from 3" to 12" diameter.

#10 PIPE FLANGE ALIGNER 3001883 [0721-0009]

RADIUS MARKERS



Models available in four sizes for scribing circles up to 80" in diameter. Folding type design--three smallest models will fit conveniently into a shirt pocket. Sturdy friction joints maintain rigidity and accuracy, and are made from lightweight, rustproof aluminum for long wear. Soapstone crayon is included. The scribe holder will accept round, square or flat soap stone crayon, pencil or steel point scribe.

MINI - UP TO 8 IN RADIUS 3001884 [0721-0010]
 SMALL - UP TO 20 IN RADIUS 3001885 [0721-0011]
 STANDARD - UP TO 24 IN RADIUS 3001886 [0721-0012]
 JUMBO - UP TO 40 IN RADIUS 3001887 [0721-0013]

#19 MULTI-TRAMMEL HEADS



Using standard half inch pipe as a trammel bar, heads feature radius set points cast in alignment with marking pointers for easy setting. Equipped with 1/4" screws and squared on the back side of perpendicular alignment. The stationary head holds a 1/4" case hardened center point. Moveable head has a 1/8" steel scribe hardened. Marks from 1-1/2" circle to any diameter needed, depending on length of pipe used as a trammel bar. Allen wrench, soapstone, scribe and pointer also included.

#19 MULTI-TRAMMEL HEADS

3001890 [0721-0016]

#21 VERSI-MAG & HOLDER



Versatile magnetic aids free up hands for other work. Versi-Mag features a single 25-pound magnet cast in a square end body that can be used for the line up of steel parts for welding or machining. Versi-Mag Holder works as a jig or line-up fixture, and can hold leads, hoses, torches or other devices. Includes two 25-pound pull magnets, each cast in an aluminum body and machined with square ends. Each one hinged to swing through a 90° angle and the bodies are fitted with either a holding pin or clamp to receive various tools.

#21 VERSI-MAG
VERSI-MAG HOLDER

3001892 [0721-0018]
3001893 [0721-0019]

#20 DIAL-ANGLE-FLANGE LEVEL



A versatile tool that can be used as a dial degree utility level or, with attachments, for two-holding flange alignment. Constructed of cast aluminum with a protective housing containing an adjustable DSL. Fitted with a threaded, self-aligning conical spacer and conical nut and bolt units for fastening the Level to a pipe flange. One of the nut and bold units is stationary, while the other slides up to 5-1/2" along a slot in the level to accommodate various flange bolt hold spacings from 2" to 5-1/2".

#20 DIAL-ANGLE-FLANGE LEVEL

3001891 [0721-0017]

#8 PRO-MAG LEVEL

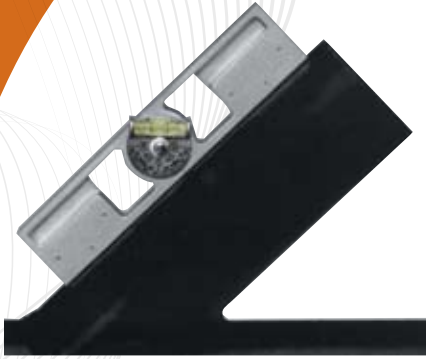

A lightweight, easy to use tool for determining angles. Unit is ideal for the pipe fitter, welder, jig builder or anyone who has to determine angles or do setup work. Includes two cast-in 25-pound pull magnets that hold securely to any steel surface. Unit has a 360° adjustable DSL with two 90° quadrants graduated in 2-1/2° increments. Cast in tables are used to convert degree-of-angle to rise-in-inches-per-foot or millimeters-per-meter. A groove on the bottom edge permits use on a small pipe.

#8 PRO-MAG LEVEL

3001881 [0721-0007]

#22 PRO-MAG BURNING SQUARE

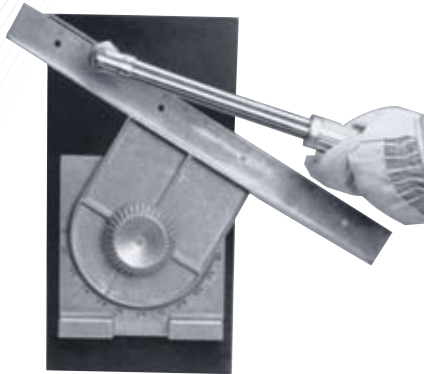

Precise tool used in structural thermal cutting and layout. Tool base is a perfect square containing powerful cast-in magnets, permitting placement in any position. Tool surface is embossed with a protractor inscribed with two 90° quadrants graduated in 1° increments. Top of the tool carries an 18" ruler blade divided in 1/8" increments and can be locked in place at the desired angle setting by hand tightening of the adjustment knob. Ruler blade is on a raised plane for use as a straight edge when flame cutting, without distortion or marring. Blade will also accept attachments or extensions that allow an overall length up to 72". Made of cast aluminum.

#22 PRO-MAG BURNING SQUARE

3001894 [0721-0020]

#28 MAGNETIC BURNING GUIDE

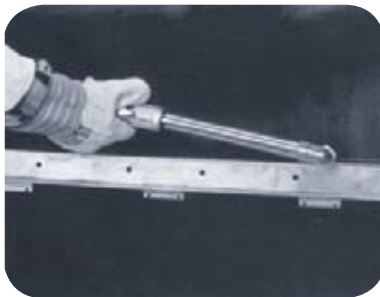

Designed for use with a burning torch or plasma cutter as straight edge, the Burning Guide is cast of strong, durable material to withstand heat spatter. Tool's base has three 30-pound pull cast-in magnets for use in any position.

#28 MAGNETIC BURNING GUIDE

3001899 [0721-0025]

ATTACHMENTS FOR #22 & #28



Attachments for #22 Pro-Mag Burning Square and #28 Magnetic Burning Guide.

#31 ATTACHMENT - 72" OVERALL LENGTH
 #30 ATTACHMENT - 48" OVERALL LENGTH
 #29 ATTACHMENT - 34" OVERALL LENGTH

3001902 [0721-0028]
 3001901 [0721-0027]
 3001900 [0721-0026]

#33 UNIVERSAL LEVEL



Designed primarily for pipe fitting applications, the Universal Level is a valuable tool for any craft required to use a level or a plumb bob:

- For structural ironworkers, the powerful holding magnets provide an extra hand.
- Electricians will find the Level useful in laying out and lining up heavy conduit.
- With the aid of a handy conversion chart, carpenters can use the Level for the layout of roof rafters.
- Multi-purpose tool features a 360-degree adjustable dial set level (DSL) that ensures accurate leveling and permits the following additional uses: setting a predetermined pitch of a string of pipe, setting the angle of laterals to a precise degree, trueing vertical runs, & two-holding flanges.

Includes two cast-in 25-pound magnets (exerting a 50-pound pull) to securely hold the unit in place on any steel surface, including the underside of a pipe or beam. This permits hands-free leveling, a welcome aid in tight spots. Bubble is mounted on a protector dial, the level may be used in any position and still read accurately. Magnets are cast in and do not interfere with the use of the Level on nonmagnetic materials, such as aluminum, copper, lumber or stone requiring leveling. For aligning pipe flanges (two-holding), the level comes with a two-threaded, self-aligning conical spacer and conical nut and bolt units, designed to fit any size bolt hole spaced between 2-1/4" and 8" centers on flanges. Permits the orientation of flange bolt holds for any size pipe.

#33 UNIVERSAL LEVEL

3001904 [0721-0030]

WRAP-A-ROUND



Economical tool for marking straight lines around pipe, or for use of a straight edge. Made out of flexible gasket material, with good resistance to heat and cold. Available in two colors, designating material type and service temperature. Gray material is used high temperature applications up to 550°F. Black material has a service temperature up to 350°F. Both are asbestos free. Wrap-A-Rounds in 3.88" and 5.00" feature a metric scale and pitch chart. All sizes are printed with a scale in inches, pitch chart, tangent chart and other useful markings. Extra small, small and special order sizes are unmarked.

| SIZE | DIMENSIONS WIDTH/LENGTH | PIPE DIAMETER | BLACK ITEM NUMBER | GRAY ITEM NUMBER |
|----------|-------------------------|---------------|---------------------|---------------------|
| EX-SMALL | 1.94" X 2' | 1" TO 3" | 3001856 [0720-0001] | 3001865 [0720-0027] |
| SMALL | 2.50" X 2' | 1" TO 3" | 3001857 [0720-0004] | 3001866 [0720-0028] |
| MEDIUM | 3.88" X 4' | 3" TO 6" | 3001858 [0720-0007] | 3001867 [0720-0029] |
| LARGE | 3.88" X 6' | 3" TO 10" | 3001859 [0720-0010] | 3001868 [0720-0030] |
| EX-LARGE | 5.00" X 7' | 4" TO 12" | 3001860 [0720-0013] | 3001869 [0720-0031] |
| EX-LARGE | 5.00" X 9' | 6" TO 16" | 3001861 [0720-0016] | 3001870 [0720-0032] |
| SPECIAL | 3.88" X LENGTH DESIRED* | | 3001862 [0720-0019] | 3001871 [0720-0033] |
| SPECIAL | 5.00" X LENGTH DESIRED* | | 3001863 [0720-0022] | 3001872 [0720-0034] |
| SPECIAL | 7.00" X LENGTH DESIRED* | | 3001864 [0720-0025] | 3001873 [0720-0035] |

*SPECIAL LENGTHS AVAILABLE UP TO A MAXIMUM OF 375'

STRESS RELIEF PADS

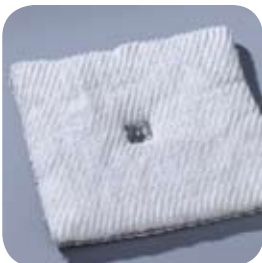

These flexible pads are made from special non-asbestos, resilient, high temperature materials. Non-combustible and chemically inert, they provide temporary insulation of welds during stress relieving of large diameter piping, ducts, vessels, or tanks. Available in 12", 24" or 48" widths and 1", 1.5", and 2" thicknesses.

| DESCRIPTION | PART NO |
|--------------------|---------|
| STRESS RELIEF PADS | HTFM |

ACCESSORIES & REPLACEMENT PARTS

| | |
|--|---------------------|
| #24 SOAPSTONE 1/4 IN X 5 IN ROUND | 3001895 [0721-0021] |
| #26 ROUND SOAPSTONE HOLDER | 3001897 [0721-0023] |
| #25 SOAPSTONE 3/16 IN X 1/2 IN X 5 IN FLAT | 3001896 [0721-0022] |
| #27 FLAT SOAPSTONE HOLDER | 3001898 [0721-0024] |
| #6 CENTERING PIN | 3001906 [0722-0001] |
| CENTERING BUSHING SET #20, #30 | 3001907 [0722-0002] |
| DIAL SET LEVEL (DSL) | 3001905 [0722-0000] |

wilsonindustries



THE HISTORY OF WILSON INDUSTRIES

Since 1957, Wilson has prided itself on being at the forefront of technology. By researching today's scientific and engineering developments and applying them to tomorrow's safety needs. Wilson has consistently produced a superior line of quality safety products.

Wilson products are designed to improve the overall working environment and assist in increasing productivity . All of our products meet or exceed OSHA specifications. Through our leadership in the safety field, the complete Wilson line has played an important part in the safety programs of various companies. When you specify Wilson products, you are assured excellent quality supported by years of experience, family pride and commitment to customer satisfaction.

Wilson

QUALITY SAFETY PRODUCTS

CUSTOMIZATION EXPERTS

Special made to order curtains and blankets are our specialty!

Wilson makes custom curtains, shrouds, covers or traps in virtually any size from our wide variety of fire resistant specialty fabrics. We electronically weld or securely sew all products to provide superior quality and long lasting protection. You design it and we will make it; or we are happy to assist you with a design. Cutouts, conveyor belt openings, machine shrouds, weighted hems, wind relief vents and doorways are just a few of the many custom features offered.

When designing a custom curtain, choose the proper fabric for the application (contact Wilson customer service for assistance at 1-800-423-4277), take into consideration special design features (cut-outs, dimensions, etc.) and determine how the curtain will be supported. Add 10% to the width dimension, if the product is intended for hanging



NOW IN STOCK!

Now that Jackson Safety and Wilson Industries have become one, we are stocking a select number of products in both of our warehouse facilities. When you see a part number in **blue** it is stocked at both our east and west warehouse facilities for your convenience.

PIONEER OF SPECTRA™ ORANGE SEE-THRU

Since 1968 the traditional Wilson Spectra brand has been the industry standard in transparent welding curtains. The development of the unique absorption scattering and filtering properties of Spectra™ curtain was based on scientific principles similar to those used by scientists who studied the Voyager probe's response to radiation exposure during its exploration of the planet Saturn.

In an independent study conducted by the United States Army at its Aberdeen Proving Grounds, Spectra™ Curtain proved to be superior to all other semitransparent welding curtains on the market today. Wilson holds three patents for the unique properties of its Spectra Curtain: Its orange color that cuts dangerous blue light; its fluorescent and white pigments scatter light; and its dimpled texture refracts and enlarges light.

Insist on a Wilson's Spectra Curtain, DO NOT be confused by other orange imitations, there is only one Spectra™ Curtains, look for the Spectra label.



SPECTRA™ SEE THRU: NO OTHER TRANSPARENT WELDING CURTAIN MANIPULATES LIGHT WAVES LIKE THE SPECTRA CURTAIN!

With its scientifically engineered, special patented PVC formula, the Spectra™ curtain absorbs, scatters and filters the light spectrum to create a safer and better working environment for the welder, surrounding co-workers, and supervisors.

The Spectra™ See-Thru Curtain constitutes the "NEAR IDEAL" transparent welding curtain:

- Eliminates dangerous Ultra Violet Radiation
- Provides good visibility like the yellow transparent welding curtain
- Minimizes the arc glare better than all other transparent curtains
- Puts light back into the welding booth to assist the welder with his work like no other welding curtain!

Each Wilson Spectra™ curtain is embossed with our distinctive trademark Wilson logo throughout the curtain. DO NOT BE CONFUSED BY OTHER ORANGE IMITATIONS, specify Spectra and look for the trademark embossed on the curtain with label.

HOW SPECTRA™ COMPARES IN 5 ZONES OF THE OPTICAL WELDING SPECTRUM

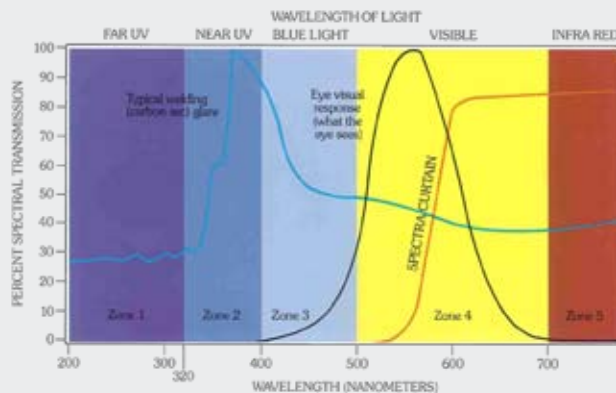

Zone 1 200-320 nm. (far u.v., flash burns)

This zone cannot be seen by the naked eye, yet the powerful and dangerous far Ultra Violet Rays within this zone can have damaging and permanent effect on the eye. Spectra™ curtain prevents the transmission of this zone, preventing flash burns.

Zone 2 320-400 nm. (near u.v.)

This zone cannot be seen by the naked eye, yet may cause such harmful effects as lens fluorescence, cataracts, and skin problems. Spectra™ curtain prevents the transmission of this zone, thus preventing these harmful effects.

Zone 3 400-500 nm. (Blue Light)

Within this zone, welding arcs product their highest percent of concentrated energy. This zone is either not seen or very dimly seen by the naked eye. However, this zone emits a blue light that may annoy or irritate the eye. Conventional transparent welding curtains usually start to transmit in this range. Spectra™ Curtain prevents the transmission of this zone, thus preventing blue light annoyance or irritation.

Zone 4 500-700 nm. (good visible light)

Within this zone, the eye has its maximum capabilities of vision. Spectra™ Curtain begins transmission in this zone and allows ample light for a safety supervised and enjoyable working environment.

Zone 5 Above 700 nm.

This zone is not seen by the naked eye and studies indicate that most welding curtain applications are not influenced within this range.

ORIGINATOR OF THE TRANSPARENT WELDING CURTAINS

Wilson Industries originated the concept of the transparent welding curtains in 1968.

- All four sides are securely hemmed by our electronic welding process for added strength and durability (except Canvas which are sewn)
- Plastic grommets provide better wearability with less possibility of separation from the curtain
- Grommets are placed 8" apart on one width side and 16" apart on both height sides
- Durable curtain materials - resists tearing
- Wide Variety of transparent welding curtains tailored to your particular welding and safety needs
- All Wilson welding curtains meet or exceed California State Fire Marshall and NFPA 701 requirements for flame resistance.



SPECTRA™ ORANGE SEE-THRU

SEE-THRU WELDING CURTAINS

Heavy duty vinyl. Filters 100% of far/near UV radiation and blue light. Arc image dispersed throughout the curtain. Puts light back into the welding booth. Use: low to high amperage. Thickness: 14 mil or 40 mil

SPECTRA SEE THRU CURTAIN - 14 MIL

| DESCRIPTION | STOCK ITEM | PART # |
|-------------|------------|----------|
| 4' X 5' | | 4520-25 |
| 4' X 6' | 3018914 | 4624-25 |
| 4' X 8' | 3018919 | 4832-25 |
| 4' X 10' | | 41040-25 |
| 5' X 5' | | 5525-25 |
| 5' X 6' | 3018944 | 5630-25 |
| 5' X 8' | 3018948 | 5840-25 |
| 5' X 10' | 3018924 | 51050-25 |
| 6' X 6' | 3018979 | 6636-25 |
| 6' X 8' | 3018985 | 6848-25 |
| 6' X 9' | | 6954-25 |
| 6' X 10' | 3018955 | 61060-25 |
| 6' X 12' | 3018959 | 61272-25 |
| 6' X 15' | | 61590-25 |

SPECTRA SEE THRU CURTAIN - 40 MIL

| DESCRIPTION | PART # |
|-------------|----------|
| 4' X 5' | 4520-28 |
| 4' X 6' | 4624-28 |
| 4' X 8' | 4832-28 |
| 4' X 10' | 41040-28 |
| 5' X 5' | 5525-28 |
| 5' X 6' | 5630-28 |
| 5' X 8' | 5840-28 |
| 5' X 10' | 51050-28 |
| 6' X 6' | 6636-28 |
| 6' X 8' | 6848-28 |
| 6' X 9' | 6954-28 |
| 6' X 10' | 61060-28 |
| 6' X 12' | 61272-28 |
| 6' X 15' | 61590-28 |

Spectra Orange See-Thru



*CUT SIZE: ACTUAL FINISHED SIZE MAY VARY 3" IN HEIGHT AND WIDTHS. CUSTOM SIZES AVAILABLE. CLEAR/COLORLESS SEE-THRU IS AVAILABLE IN 14 AND 40 MIL, BUT IS NOT TO BE USED FOR WELDING OR U.V. FILTRATION.

*ITEMS IN BLUE ARE STOCKED IN BOTH OUR DISTRIBUTION FACILITIES

GOLD SEE-THRU

SEE-THRU WELDING CURTAINS

Heavy duty vinyl. Stops far/near U.V. radiation. Excellent blue light protection. Arc image dispersed throughout the curtain. Allows supervision and a bright work environment. Use: low to medium amperage. Thickness: 14 mil or 40 mil



Gold See-Thru

GOLD SEE THRU CURTAIN - 14 MIL

| DESCRIPTION | STOCK ITEM | PART # |
|-------------|------------|----------|
| 4' X 5' | | 4520-50 |
| 4' X 6' | | 4624-50 |
| 4' X 8' | | 4832-50 |
| 4' X 10' | | 41040-50 |
| 5' X 5' | | 5525-50 |
| 5' X 6' | | 5630-50 |
| 5' X 8' | 3018945 | 5840-50 |
| 5' X 10' | | 51050-50 |
| 6' X 6' | 3018975 | 6636-50 |
| 6' X 8' | 3018981 | 6848-50 |
| 6' X 9' | | 6954-50 |
| 6' X 10' | | 61060-50 |
| 6' X 12' | | 61272-50 |
| 6' X 15' | | 61590-50 |

GOLD SEE THRU CURTAIN - 40 MIL

| DESCRIPTION | PART # |
|-------------|----------|
| 4' X 5' | 4520-54 |
| 4' X 6' | 4624-54 |
| 4' X 8' | 4832-54 |
| 4' X 10' | 41040-54 |
| 5' X 5' | 5525-54 |
| 5' X 6' | 5630-54 |
| 5' X 8' | 5840-54 |
| 5' X 10' | 51050-54 |
| 6' X 6' | 6636-54 |
| 6' X 8' | 6848-54 |
| 6' X 9' | 6954-54 |
| 6' X 10' | 61060-54 |
| 6' X 12' | 61272-54 |
| 6' X 15' | 61590-54 |

GREEN & GRAY SEE-THRU

SEE-THRU WELDING CURTAINS

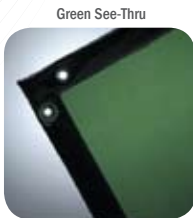

Green See-Thru



Gray See-Thru

Heavy duty vinyl. Stops far U.V. radiation. Good blue light protection. Decreases total light from welding arc. Good visibility into higher amperage welding areas. Use: medium to medium high amperage in electric arc welding. Thickness: 14 mil

GREEN SEE THRU CURTAIN - 14 MIL

| DESCRIPTION | STOCK ITEM | PART # |
|-------------|------------|----------|
| 4' X 5' | | 4520-60 |
| 4' X 6' | | 4624-60 |
| 4' X 8' | | 4832-60 |
| 4' X 10' | | 41040-60 |
| 5' X 5' | | 5525-60 |
| 5' X 6' | 3018941 | 5630-60 |
| 5' X 8' | 3018946 | 5840-60 |
| 5' X 10' | 3018922 | 51050-60 |
| 6' X 6' | 3018976 | 6636-60 |
| 6' X 8' | 3018982 | 6848-60 |
| 6' X 9' | | 6954-60 |
| 6' X 10' | 3018952 | 61060-60 |
| 6' X 12' | 3018957 | 61272-60 |
| 6' X 15' | | 61590-60 |

GRAY SEE THRU CURTAIN - 14 MIL

| DESCRIPTION | PART # |
|-------------|----------|
| 4' X 5' | 4520-80 |
| 4' X 6' | 4624-80 |
| 4' X 8' | 4832-80 |
| 4' X 10' | 41040-80 |
| 5' X 5' | 5525-80 |
| 5' X 6' | 5630-80 |
| 5' X 8' | 5840-80 |
| 5' X 10' | 51050-80 |
| 6' X 6' | 6636-80 |
| 6' X 8' | 6848-80 |
| 6' X 9' | 6954-80 |
| 6' X 10' | 61060-80 |
| 6' X 12' | 61272-80 |
| 6' X 15' | 61590-80 |

PLASMA SEE-THRU

SEE-THRU WELDING CURTAINS

Extra dark green (shade 8) Heavy-duty vinyl . Stops far U.V. radiation. Superior blue light protection. Excellent for plasma cutting or extremely bright welding arcs. Thickness: 14 mil



Plasma See-Thru

PLASMA SEE THRU CURTAIN - (DINS #32504)

| DESCRIPTION | PART# |
|-------------|----------|
| 4' X 5' | 4520-90 |
| 4' X 6' | 4624-90 |
| 4' X 8' | 4832-90 |
| 4' X 10' | 41040-90 |
| 5' X 5' | 5525-90 |
| 5' X 6' | 5630-90 |
| 5' X 8' | 5840-90 |

| DESCRIPTION | PART # |
|-------------|----------|
| 5' X 10' | 51050-90 |
| 6' X 6' | 6636-90 |
| 6' X 8' | 6848-90 |
| 6' X 9' | 6954-90 |
| 6' X 10' | 61060-90 |
| 6' X 12' | 61272-90 |
| 6' X 15' | 61590-90 |

GREEN CANVAS

OPAQUE WELDING CURTAINS

Medium weight, resistant to fire, water and mildew. Recommended for most welding applications.

GREEN CANVAS

| DESCRIPTION | STOCK ITEM | PART # | DESCRIPTION | STOCK ITEM | PART # |
|-------------|------------|----------|-------------|------------|----------|
| 4' X 5' | | 4520-15 | 5' X 10' | | 51050-15 |
| 4' X 6' | | 4624-15 | 6' X 6' | 3018857 | 6636-15 |
| 4' X 8' | | 4832-15 | 6' X 8' | 3018858 | 6848-15 |
| 4' X 10' | | 41040-15 | 6' X 9' | | 6954-15 |
| 5' X 5' | | 5525-15 | 6' X 10' | | 61060-15 |
| 5' X 6' | 3018852 | 5630-15 | 6' X 12' | | 61272-15 |
| 5' X 8' | 3018853 | 5840-15 | 6' X 15' | | 61590-15 |

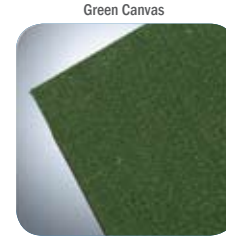

Green Canvas

RIP-STOP

OPAQUE WELDING CURTAINS

Vinyl laminated polyester scrim. Withstands heavy abrasion and abuse, resists oil, water and most acids. Recommended for most welding applications. May be combined with any transparent vinyl for visibility and strength. Colors: yellow (85), green (95), orange (75), blue (65), and black (55)

RIP-STOP *ADD COLOR CODE AFTER EACH PART NO. PREFIX FOR ORDERING. (EX. 4520-85)

| DESCRIPTION | PART # | DESCRIPTION | PART # |
|-------------|---------|-------------|---------|
| 4' X 5' | 4520-* | 5' X 10' | 51050-* |
| 4' X 6' | 4624-* | 6' X 6' | 6636-* |
| 4' X 8' | 4832-* | 6' X 8' | 6848-* |
| 4' X 10' | 41040-* | 6' X 9' | 6954-* |
| 5' X 5' | 5525-* | 6' X 10' | 61060-* |
| 5' X 6' | 5630-* | 6' X 12' | 61272-* |
| 5' X 8' | 5840-* | 6' X 15' | 61590-* |

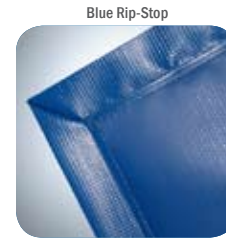

Blue Rip-Stop

INSTANT CURTAIN

SEE-THRU WELDING CURTAINS



CUSTOMIZE YOUR OWN CURTAIN.

Simply cut off the amount of curtain you need and hang it. Transparent welding curtain material with grommets every 8" on one width side (no hems). 75" wide (long).

| DESCRIPTION | PART # |
|---|---------|
| SPECTRA ORANGE SEE-THRU 14 MIL, HEIGHT 5' | IC60-25 |
| SPECTRA ORANGE SEE-THRU 14 MIL, HEIGHT 6' | IC72-25 |
| GOLD (YELLOW) SEE-THRU 14 MIL, HEIGHT 5' | IC60-50 |
| GOLD (YELLOW) SEE-THRU 14 MIL, HEIGHT 6' | IC72-50 |
| GREEN SEE-THRU 14 MIL, HEIGHT 6' | IC72-60 |
| GRAY SEE-THRU 14 MIL, HEIGHT 6' | IC72-80 |

GLIDE - N - FOLD



Accordion style folding curtains offer a space saving configuration with a sharp, clean appearance. Sold in 24" width multiples.

(Add 10% to widths for proper hanging)

| DESCRIPTION | PART # |
|--|---------|
| SPECTRA ORANGE SEE-THRU 12" FOLD SECTIONS, 45 MIL | SP-28GF |
| CLR (COLORLESS) SEE-THRU 12" FOLD SECTIONS, 45 MIL | SP-44GF |
| RIP-STOP, VINYL LAMINATE 12" FOLD SECTIONS | SP-**GF |

(ADD COLOR CODE AFTER EACH PART NO. PREFIX FOR ORDERING RIP STOP
COLORS: GREEN-95, YELLOW-85, ORANGE-75, BLUE-65, OR BLACK-55)

*CUT SIZE: ACTUAL FINISHED SIZE MAY VARY 3" IN HEIGHT AND WIDTHS. CUSTOM SIZES AVAILABLE.
CLEAR/COLORLESS SEE-THRU IS AVAILABLE IN 14 AND 40 MIL, BUT IS NOT TO BE USED FOR WELDING OR U.V. FILTRATION.

ROLL GOODS

Spectra Orange See-Thru



Gold See-Thru



Green See-Thru

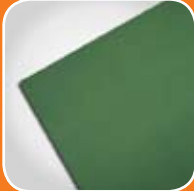

Gray See-Thru



Plasma See-Thru



Blue Rip-Stop

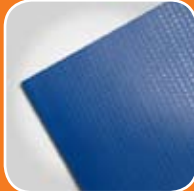

Green Canvas



Electro-Safe



SPECTRA™ ORANGE SEE-THRU* The “Ideal” transparent welding curtain material. Patented formula, heavy duty 14 mil vinyl film. Stops dangerous U.V. radiation and minimizes arc glare.

| PART NO | COLOR | WIDTH | APPROX. YDS/ROLL | APPROX. WT/ROLL |
|---------|----------------|-------|------------------|-----------------|
| 250-72 | SPECTRA ORANGE | 72" | 100 | 165 LBS |
| 250-60 | SPECTRA ORANGE | 60" | 100 | 135 LBS |

SPECTRA™ ORANGE SEE-THRU FORTY* Extra thick (40 mil) patented Spectra. Provides extra strength, longevity and added abrasion resistance.

| PART NO | COLOR | WIDTH | APPROX. YDS/ROLL | APPROX. WT/ROLL |
|---------|------------|-------|------------------|-----------------|
| 280-48 | ORANGE/RED | 48" | 50 | 160 LBS |

SEE-THRU WELDING MATERIAL* Heavy duty 14 mil vinyl film. Stops dangerous U.V. radiation.

| PART NO | COLOR | WIDTH | APPROX. YDS/ROLL | APPROX. WT/ROLL |
|---------|-------|-------|------------------|-----------------|
| 500-60 | GOLD | 60" | 100 | 135 LBS |
| 500-72 | GOLD | 72" | 100 | 165 LBS |
| 600-72 | GREEN | 72" | 100 | 165 LBS |
| 800-72 | GRAY | 72" | 100 | 165 LBS |

SEE-THRU FORTY* Stops dangerous U.V. radiation. 40 mil thickness provides extra strength, longevity and added abrasion resistance.

| PART NO | COLOR | WIDTH | APPROX. YDS/ROLL | APPROX. WT/ROLL |
|---------|-------|-------|------------------|-----------------|
| 540-48 | GOLD | 48" | 50 | 160 LBS |

PLASMA SEE-THRU* Heavy duty 14 mil vinyl. Stops dangerous U.V. radiation.

| PART NO | COLOR | WIDTH | APPROX. YDS/ROLL | APPROX. WT/ROLL |
|---------|------------------|-------|------------------|-----------------|
| 900-72 | EXTRA DARK GREEN | 72" | 100 | 165 LBS |

RIP-STOP* Vinyl laminated polyester scrim. Resists tearing ripping, oil, mildew, water and most acids.

| PART NO | COLOR | WIDTH | APPROX. YDS/ROLL | APPROX. WT/ROLL |
|---------|--------|-------|------------------|-----------------|
| 550-61 | BLACK | 61" | 75 | 105 LBS |
| 650-61 | BLUE | 61" | 75 | 105 LBS |
| 750-61 | ORANGE | 61" | 75 | 105 LBS |
| 850-72 | YELLOW | 72" | 75 | 130 LBS |
| 950-72 | GREEN | 72" | 75 | 130 LBS |

CANVAS* Medium weight, resistant to fire, water and mildew.

| PART NO | COLOR | WIDTH | APPROX. YDS/ROLL | APPROX. WT/ROLL |
|---------|--------|-------|------------------|-----------------|
| 110-60 | GREEN | 60" | 100 | 200 LBS |
| 150-60 | YELLOW | 60" | 100 | 200 LBS |

CLEAR VINYL* Heavy duty 14 mil colorless vinyl film. Excellent for draft curtain, chipping, grinding, paint and general use (not to be used for welding). U.V. absorbers inhibit cracking.

| PART NO | COLOR | WIDTH | APPROX. YDS/ROLL | APPROX. WT/ROLL |
|---------|---------------|-------|------------------|-----------------|
| 400-60 | CLR/COLORLESS | 60" | 100 | 135 LBS |
| 400-72 | CLR/COLORLESS | 72" | 100 | 165 LBS |

CLEAR FORTY* heavy duty 40 mil colorless vinyl film. Excellent for extra protection and abrasion resistance (not to be used for welding). U.V. absorbers inhibit cracking.

| PART NO | COLOR | WIDTH | APPROX. YDS/ROLL | APPROX. WT/ROLL |
|---------|---------------|-------|------------------|-----------------|
| 440-48 | CLR/COLORLESS | 48" | 50 | 160 LBS |

SEE-THRU HEAVY GAUGE* Vinyls. Transparent - welding, sound reduction, chip control.

| PART NO | COLOR | WIDTH | APPROX. YDS/ROLL | APPROX. WT/ROLL |
|----------|-------|-------|------------------|-----------------|
| S848-40 | CLEAR | 48" | 40 | 240 LBS |
| S1648-40 | CLEAR | 48" | 20 | 240 LBS |
| S848-50 | AMBER | 48" | 40 | 240 LBS |

ELECTRO-SAFE heavy duty 12 mil transparent vinyl film. Grounding scrim eliminates static electricity. Grounds to 0 kv. Excellent for clean rooms, dust-free environments, computer enclosures.

| PART NO | COLOR | WIDTH | APPROX. YDS/ROLL | APPROX. WT/ROLL |
|---------|---------------|-------|------------------|-----------------|
| 450-54 | CLR/COLORLESS | 54" | 94 | 100 LBS |

*Meets California Fire Marshal Requirements.

CUSTOM FABRICATION

Wilson makes custom curtains, shrouds, covers or tarps in virtually any size from our wide variety of fire resistant specialty fabrics. We electronically weld or securely sew all products to provide superior quality and long lasting protection. You design it and we will make it; or we're happy to assist you with a design. Cutouts, conveyor belt openings, machine shrouds, weighted hems, wind relief vents and doorways are just a few of the many custom features offered. When designing a custom curtain, choose the proper fabric for the application (contact Wilson customer service for assistance), take into consideration special design features (cut-outs, dimensions, etc.) and determine how the curtain will be supported. Add 10% to the width dimension, if the product is intended for hanging. Special made to order curtains are our specialty!



wilsonindustries

WILSON'S PREMIUM SCREEN: STUR-D-SCREEN

Stur-D-Screen features a freestanding, strong square tubing that provides neat appearance and sturdy platform legs. No curtain gapping between posts ensures a secure and safe area. Easy to assemble with interchangeable parts. Available in multi-panel screens or cubicles.

The complete package includes square steel frame, brackets, platform "T" legs, lacing ties, and safety curtain - all shipped disassembled.



FREESTANDING, PORTABLE SAFETY SCREENS OFFER A UNIQUE COMBINATION OF STRENGTH, STURDINESS AND SAFETY.



Shown in image:
Square steel tubing provide strength and exclusive bolted corner clamps assure a tight, secure fit

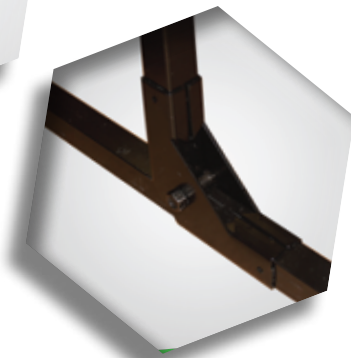

Shown in image:
Platform legs minimize frame wobble and sway

- **STRENGTH** - Solid square steel tubing eliminates slipping and twisting. Exclusive bolted corner clamps assure a tight, secure fit.
- **SAFETY** - Combined with Wilson safety fabrics, Wilson Stur-D-Screens ensure optimal protection for welding areas, machine shop chip control and many other applications.
- **STURDINESS** - Square steel tubing, bolted corner clamps and platform legs minimize frame wobble and sway.

The remarkable strength of the Stur-D-Screen frame is demonstrated here. Solid square steel tubing, exclusive bolted corner clamps and platform legs provide exceptional strength and sturdiness - enough to support these 200 pound welding tanks.



wilsonindustries

- **VARIETY** - Allows for a variety of configurations to fit any work environment without having to worry about stability of the frame. Creating a work environment with more than one screen is easy, it only takes one extra connector, SDSH02.

The Stur-D-Screen frame (R106668-00) adjusts to 5'x6', 6'x6' and 6'x8' in size to fit 85% of the most common size of welding screen curtains for convenience and ease.



DESCRIPTION
FRAME ONLY - FITS 5' X 5', 5' X 6' 6' X 8'
CONNECTOR FOR STUR-D-SCREENS

PART #
R106668-00
SDSH02

| FRAME SIZE | STOCK ITEM SPECTRA | PART # W/ SPECTRA 14 MIL | PART # W/ GOLD 14 MIL | PART # W/ GREEN 14 MIL | PART # W/ GRAY 14 MIL | PART # W/ PLASMA 14 MIL | PART # W/ RIP-STOP* | PART # W/ GREEN CANVAS | STOCK ITEM FRAME | PART # FRAME ONLY |
|-------------------------|--------------------|--------------------------|-----------------------|------------------------|-----------------------|-------------------------|---------------------|------------------------|------------------|-------------------|
| 4' X 5' - SINGLE PANEL | | R1045-25 | R1045-50 | R1045-60 | R1045-80 | R1045-60 | R1045-* | R1045-15 | | R1045-00 |
| 5' X 5' - SINGLE PANEL | | R1055-25 | R1055-50 | R1055-60 | R1055-80 | R1055-60 | R1055-* | R1055-15 | | R1055-00 |
| 6' X 4' - SINGLE PANEL | | R1064-25 | R1064-50 | R1064-60 | R1064-80 | R1064-60 | R1064-* | R1064-15 | | R1064-00 |
| 6' X 6' - SINGLE PANEL | 3019240 | R1066-25 | R1066-50 | R1066-60 | R1066-80 | R1066-60 | R1066-* | R1066-15 | 3019175 | R1066-00 |
| 6' X 8' - SINGLE PANEL | 3019248 | R1068-25 | R1068-50 | R1068-60 | R1068-80 | R1068-60 | R1068-* | R1068-15 | 3019176 | R1068-00 |
| 6' X 10' - SINGLE PANEL | | R10610-25 | R10610-50 | R10610-60 | R10610-80 | R10610-60 | R10610-* | R10610-15 | | R10610-00 |
| 6' X 12' - SINGLE PANEL | | R10612-25 | R10612-50 | R10612-60 | R10612-80 | R10612-60 | R10612-* | R10612-15 | | R10612-00 |
| 5' X 5' - TWO PANEL | | R2055-25 | R2055-50 | R2055-60 | R2055-80 | R2055-60 | R2055-* | R2055-15 | | R2055-00 |
| 6' X 4' - TWO PANEL | | R2064-25 | R2064-50 | R2064-60 | R2064-80 | R2064-60 | R2064-* | R2064-15 | | R2064-00 |
| 6' X 6' - TWO PANEL | | R2066-25 | R2066-50 | R2066-60 | R2066-80 | R2066-60 | R2066-* | R2066-15 | | R2066-00 |
| 6' X 8' - TWO PANEL | | R2068-25 | R2068-50 | R2068-60 | R2068-80 | R2068-60 | R2068-* | R2068-15 | | R2068-00 |
| 5' X 5' - THREE PANEL | | R3055-25 | R3055-50 | R3055-60 | R3055-80 | R3055-60 | R3055-* | R3055-15 | | R3055-00 |
| 6' X 4' - THREE PANEL | | R3064-25 | R3064-50 | R3064-60 | R3064-80 | R3064-60 | R3064-* | R3064-15 | | R3064-00 |
| 6' X 6' - THREE PANEL | | R3066-25 | R3066-50 | R3066-60 | R3066-80 | R3066-60 | R3066-* | R3066-15 | | R3066-00 |
| 6' X 8' - THREE PANEL | | R3068-25 | R3068-50 | R3068-60 | R3068-80 | R3068-60 | R3068-* | R3068-15 | | R3068-00 |
| 6' X 6' - FOUR PANEL | | R4066-25 | R4066-50 | R4066-60 | R4066-80 | R4066-60 | R4066-* | R4066-15 | | R4066-00 |
| 6' X 8' - FOUR PANEL | | R4068-25 | R4068-50 | R4068-60 | R4068-80 | R4068-60 | R4068-* | R4068-15 | | R4068-00 |

*ADD COLOR CODE AFTER EACH PART NO. PREFIX FOR ORDERING. RIP-STOP IS AVAILABLE IN GREEN-95, YELLOW-85, BLUE-65, RED-35 OR BLACK-55. (EX. 4520-85)
RE-COVERS (SAFETY CURTAINS) ARE AVAILABLE UPON REQUEST.
PER OSHA RECOMMENDATIONS, ALL CURTAINS ALLOW 1FT. CLEARANCE AT FLOOR.

STUR-D-SHIELD



Lightweight, compact and easy to assemble, the portable Stur-D-Shield folds flat when not in use. Provides all the features of Stur-D-Screen and is perfect as a tabletop welding screen, portable maintenance screen or compact safety screen. Fits easily into a truck or van. Shipped disassembled.

Available with Spectra See-Thru, Gold See-Thru, Green See-Thru, Green Canvas, Weld-O-Glass 3330R (Red Silicone), Weld-O-Glass 900FC (Uncoated white fiberglass).

| H" X W" | PART # W/ SPECTRA 14 MIL | PART # W/ GOLD 14 MIL | PART # W/ GREEN 14 MIL | PART # W/ GREEN CANVAS | PART # W/ W-O-G 900FC | PART # W/ W-O-G 3000R |
|--------------|--------------------------|-----------------------|------------------------|------------------------|-----------------------|-----------------------|
| 36"H X 48"W | B342-25 | B342-50 | B342-60 | B342-15 | B342-900 | B342-3000 |
| 36"H X 60"W | B521-25 | B521-50 | B521-60 | B521-15 | B521-900 | B521-3000 |
| 36"H X 72"W | B631-25 | B631-50 | B631-60 | B631-15 | B631-900 | B631-3000 |
| 60"H X 144"W | B754-25 | B754-50 | B754-60 | B754-15 | B754-900 | B754-3000 |
| 72"H X 144"W | B864-25 | B864-50 | B864-60 | B864-15 | B864-900 | B864-3000 |

MODULAR SCREEN

This industrial-grade modular frame can be configured to fit 85% of all welding screen size requirements. The highly adaptable, push button splice-tubing steel construction allows for this single frame to adjust from **6" wide to 8" wide**. The frame adjusts to 5'x6', 6'x6' and 6'x8' in size to fit the most common size of welding screen curtains for convenience and ease. Simply snap spring-pins into place. The Modular Screen is designed to be used individually or quickly hinged together to form multiple panel units. The modular screen is durable, lightweight and easy to assemble.

- Adjust to sizes: 5'x6', 6'x6' and 6'x8'
- Steel tubing with an outside diameter of 7/8"
- 24" crossbar legs standard with all screens
- Exclusive corner clamp and hinge assembly
- Packaged to ship UPS standard and store on warehouse pallet racks

| DESCRIPTION | STOCK ITEM | PART # |
|----------------------|------------|--------|
| FRAME ONLY - 1 PANEL | 3019148 | M66-68 |



Shown in image:
Simply snap spring pins into place for easy assemble

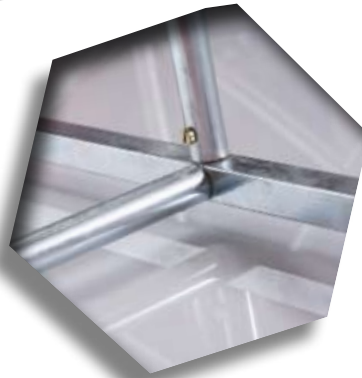

Shown in image:
Crossbar legs standard with all screens for stability



Shown in image:
7/8" round steel tubing for a durability

wilsonindustries

KITS INCLUDE WELDING SCREEN OF YOUR CHOICE!

The new Modular Screen is available in kits for your ordering convenience. The kits are designed to meet the most common welding screen requirements and include a Modular Screen frame and your choice of screen material size to either 5'x6', 6'x6' or 6'x8'. You can also purchase the standard size screen material separately. Kits are packaged to meet UPS specifications to reduce shipping cost.

| H' X W' | PART # W/ SPECTRA 14 MIL | PART # W/ GOLD 14 MIL | PART # W/ GREEN 14 MIL | PART # W/ GRAY 14 MIL | PART # W/ PLASMA 14 MIL | PART # W/ CANVAS DUCK | PART # W/ RIP-STOP* |
|---------|-----------------------------|--------------------------|---------------------------|--------------------------|----------------------------|--------------------------|------------------------|
| 5' X 6' | M56-25 | M56-50 | M56-60 | M56-80 | M56-90 | M56-15 | M56-** |
| 6' X 6' | M66-25 | M66-50 | M66-60 | M66-80 | M66-90 | M66-15 | M66-** |
| 6' X 8' | M68-25 | M68-50 | M68-60 | M68-80 | M68-90 | M68-15 | M68-** |

**ADD COLOR CODE AFTER EACH PART# PREFIX FOR ORDERING. RIP-STOP IS AVAILABLE IN GREEN-95, YELLOW-85, BLUE-65, RED-35) OR BLACK-55). RE-COVERS (SAFETY CURTAINS) ARE AVAILABLE UPON REQUEST. PER OSHA RECOMMENDATIONS, ALL CURTAINS ALLOW 1FT. CLEARANCE AT FLOOR.



TRI-FOLD SCREEN

Wilson Tri-Fold Screen offers flexible, lightweight and durable protection for a variety of welding and industrial applications. Our unique swing arm feature adapts to any angle or shape. Wilson Tri-Fold consists of sturdy 1" square steel tubing, compression brackets, platform legs and wrap-around safety curtain. This screen measures 6' high with a 6' wide center panel and 4' wide side panels. Available in all Wilson See-Thru fabrics.



| DESCRIPTION | PART # |
|-------------------------|-----------|
| SPECTRA ORANGE SEE-THRU | T36464-25 |
| GOLD (YELLOW) SEE-THRU | T36464-50 |

Per OSHA recommendations, all curtains allow 1ft. clearance at floor.

ACCESSORIES



WIND CONTROL VALVE

Valve allows bottom hem to be filled with water, sand, etc. Provides curtain ballast. One valve every 10' recommended.

| PART # | DESCRIPTION |
|--------|--------------------|
| WC-1 | WIND CONTROL VALVE |



NYLON TIES

Adjustable nylon ties. Fit 3/4" to 2" outside diameter pipe.

| PART # | DESCRIPTION |
|--------|-------------|
| 800 | NYLON TIES |



HEM WEIGHT CHAIN

Flexible link chain. Weights and stabilizes safety/welding curtains. Factory installed into bottom hem of fabric.

| PART # | DESCRIPTION |
|--------|------------------|
| BC015 | HEM WEIGHT CHAIN |



PATCH KIT

30 in. by 36 in. material with adhesive backing.

| PART # | DESCRIPTION |
|--------|-------------|
| PK-25 | SPECTRA |
| PK-50 | GOLD |
| PK-60 | GREEN |
| PK-80 | GRAY |



GROMMETS

Additional heavy-duty vinyl or brass grommets may be incorporated into any curtain or blanket material.

| PART # | DESCRIPTION |
|--------|-------------|
| GR15 | VINYL |
| GR20 | BRASS |



E-Z FAS'N FASTENER

1-inch wide nylon hook and loop material for joining sections of curtains or other materials together. Press together to close, and pull apart to open.

| PART # | DESCRIPTION |
|--------|-------------|
| EZ005 | E-Z FAS'N |



CURTAIN HOOKS

Heavy-duty hooks for use with welding curtains. Fit 1-1/2" to 2" outside diameter pipe.

| STOCKED IN BELMONT | PART # | DESCRIPTION |
|--------------------|--------|---------------|
| 3019060 | 100 | CURTAIN HOOKS |



AIR VENT MESH

Heavy-duty vinyl mesh allows air circulation and ventilation. Does not filter UV radiation. CFM approved.

| PART # | DESCRIPTION |
|--------|---------------|
| AVM-10 | AIR VENT MESH |



CASTERS

Two-inch diameter rubber wheel, swivel casters provide rolling portability for tubular frame screens. Adjustable.

| PART # | DESCRIPTION |
|--------|--------------|
| CAS-1 | SINGLE-PANEL |
| CAS-2 | TWO-PANEL |
| CAS-3 | THREE-PANEL |
| CAS-4 | FOUR-PANEL |



INSPECTION WINDOW

Shade 8, 20" x 25" flexible window permits viewing of weld puddle through welding screens or shields. Attaches with E-Z FAS'N Fastener.

| PART # | DESCRIPTION |
|--------|-------------------|
| IW007 | INSPECTION WINDOW |

WELD-O-GLASS BLANKETS



HIGH TEMPERATURE FABRICS

Recognizing the need for a replacement for harmful asbestos, Wilson Industries turned to the science of metallurgy in order to perfect their fiberglass, high-temperature fabric, Weld-O-Glass.

Wilson Weld-O-Glass fabrics are used to protect equipment and personnel near hazardous operations, such as welding, flame cutting, grinding or spraying. The Weld-O-Glass family of fabrics is made up of fiberglass and silica materials with working temperatures ranging from 600°F to 2000°F. These fabrics can be made into blankets, hanging curtains or are available as roll goods.

Weld-O-Glass Uses

- Welding Slag Protection, Stress Relief, Oven Door Insulation, Pig-tails, Gaskets Low Coiling/Tempering, Heat Containment, Personnel Heat Protection, Machine Covers, Pipe and Weld Wrapping

Wilson recommends the use of welding blankets in multiple layers to attain proper molten metal and radiant heat protection. Blankets are hemmed on all four sides and have grommets in each corner and on 36" centers. Actual finished size of blanket may vary 3" in height and width.

18 OZ FIBERGLASS - UNCOATED

FOR LIGHT USE



Heat-treating up to 800°F. Pipe wrap. Not recommended for molten metal slag protection. Color: White

| DESCRIPTION | PART NO |
|---------------------|------------|
| 3' X 3' | 3309-1850 |
| 5' X 5' | 5525-1850 |
| 5' X 10' | 51050-1850 |
| 6' X 6' | 6636-1850 |
| 6' X 8' | 6848-1850 |
| 6' X 9' | 6954-1850 |
| ROLL-60" X 50 YARDS | 1850 |

15 OZ FIBERGLASS - ACRYLIC COATED

FOR LIGHT USE



Light spark and spatter protection. To be used on a vertical or angles plane. Working temperature 600°F. (VP) Color: Gray

| DESCRIPTION | PART NO |
|---------------------|---------|
| ROLL-60" X 50 YARDS | 3001 |

16 OZ FIBERGLASS - NEOPRENE COATED

FOR LIGHT USE

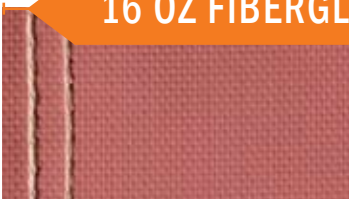

Light spark and spatter protection. To be used on a vertical or angled plane. Working temperature 600°F (VP) Color: Salmon

| DESCRIPTION | PART NO |
|---------------------|--------------|
| 3' X 3' | 3309-2000TP |
| 5' X 5' | 5525-2000TP |
| 5' X 10' | 51050-2000TP |
| 6' X 6' | 6636-2000TP |
| 6' X 8' | 6848-2000TP |
| 6' X 9' | 6954-2000TP |
| ROLL-38" X 50 YARDS | 2000TP |

24 & 35 OZ FIBERGLASS - UNCOATED

FOR MEDIUM TO HEAVY USE



Heat treating up to 800°F. 35 oz. provides extra weight for added durability. Color: White

| DESCRIPTION | PART NO 24 OZ | PART NO 35 OZ |
|---------------------|------------------|------------------|
| 3' X 3' | 3309-900 | 3309-1000 |
| 5' X 5' | 5525-900 | 5525-1000 |
| 5' X 10' | 51050-900 | 51050-1000 |
| 6' X 6' | 6636-900 | 6636-1000 |
| 6' X 8' | 6848-900 | 6848-1000 |
| 6' X 9' | 6954-900 | 6954-1000 |
| ROLL-40" X 50 YARDS | 900FC | |
| ROLL-60" X 50 YARDS | 900FC | 1000FC |

24 & 30 OZ FIBERGLASS - NEOPRENE COATED

FOR MEDIUM TO HEAVY USE

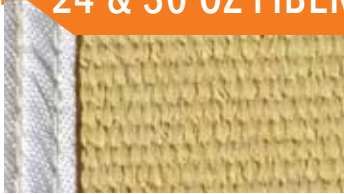

One side coated with neoprene. Good spark and spatter protection. 24 oz. medium duty and 30 oz. heavy duty welding blanket. Working temperature 600°F. (VP) Color: Yellow

| DESCRIPTION | PART NO 24 OZ | STOCK ITEM | PART NO 30 OZ |
|---------------------|------------------|------------|------------------|
| 3' X 3' | 3309-2624 | | 3309-2600 |
| 5' X 5' | 5525-2624 | | 5525-2600 |
| 5' X 10' | 51050-2624 | | 51050-2600 |
| 6' X 6' | 6636-2624 | 3018750 | 6636-2600 |
| 6' X 8' | 6848-2624 | 3018751 | 6848-2600 |
| 6' X 9' | 6954-2624 | | 6954-2600 |
| ROLL-40" X 50 YARDS | 2624 | | 2600 |
| ROLL-60" X 50 YARDS | 2624 | | 2600 |
| ROLL-72" X 50 YARDS | 2624 | | 2600 |

24 OZ FIBERGLASS - VERMICULITE COATED

FOR MEDIUM TO HEAVY USE

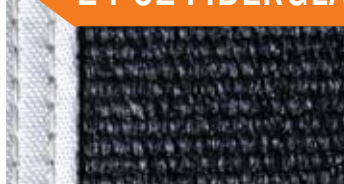

Good spark and spatter protection. Medium to heavy duty welding blanket. Good for heat treating. Working temperature 1000°F. Color: Black

| DESCRIPTION | STOCK ITEM | PART NO |
|---------------------|------------|-----------|
| 3' X 3' | | 3309-906 |
| 5' X 5' | | 5525-906 |
| 5' X 10' | | 51050-906 |
| 6' X 6' | 3018803 | 6636-906 |
| 6' X 8' | 3018805 | 6848-906 |
| 6' X 9' | | 6954-906 |
| ROLL-40" X 50 YARDS | | 906 |
| ROLL-60" X 50 YARDS | | 906 |
| ROLL-72" X 50 YARDS | | 906 |

32 OZ FIBERGLASS - SILICONE COATED

FOR HEAVY USE



Good spark and spatter protection. To be used on a vertical or angled plane. No halides or chlorides. Working temperature 600°F. (VP) Color: Red

| DESCRIPTION | PART NO |
|---------------------|------------|
| 3' X 3' | 3309-3000 |
| 5' X 5' | 5525-3000 |
| 5' X 10' | 51050-3000 |
| 6' X 6' | 6636-3000 |
| 6' X 8' | 6848-3000 |
| 6' X 9' | 6954-3000 |
| ROLL-38" X 50 YARDS | 3000R |
| ROLL-60" X 50 YARDS | 3000R |

15 OZ CARBONIZED ACRYLIC FELT

FOR HEAVY USE



Light all purpose welding blankets. Extremely heat and fire resistant. Melting temperature up to 3000°F

| DESCRIPTION | STOCK ITEM | PART NO |
|---------------------|------------|------------|
| 3' X 3' | | 3309-5180 |
| 5' X 5' | | 5525-5180 |
| 5' X 10' | | 51050-5180 |
| 6' X 6' | 3018788 | 6636-5180 |
| 6' X 8' | | 6848-5180 |
| 6' X 9' | | 6954-5180 |
| ROLL-72" X 50 YARDS | | 5180 |

18 & 36 OZ SILICA - UNCOATED

FOR MEDIUM TO HEAVY USE



Good spark and spatter protection. 18 oz. medium duty and 36 oz. heavy welding blanket. Good for heat treating. Work temperature 1700°F. Color: Tan

| DESCRIPTION | PART NO 18 OZ | PART NO 36 OZ |
|---------------------|------------------|------------------|
| 3' X 3' | 3309-21900 | 3309-23700 |
| 5' X 5' | 5525-21900 | 5525-23700 |
| 5' X 10' | 51050-21900 | 51050-23700 |
| 6' X 6' | 6636-21900 | 6636-23700 |
| 6' X 8' | 6848-21900 | 6848-23700 |
| 6' X 9' | 6954-21900 | 6954-23700 |
| ROLL-36" X 50 YARDS | 2-1900 | 2-3700 |



HOW TO ORDER

- Select appropriate fabric for application
 - Fire/Welding Blanket** - (a)1000FC, (b)2600, (c)906, (d)900FC, (e)2624
 - Slag Protection** - (a)3000R, (b) 3001, (c)906, (d)2600, (e)2000G
 - Furnace Blanket** - (a)2-3700, (b)2600AMA
 - Stress Relief to 800°F** - (a)1000FC, (b)900FC, (c)906
 - Extra High Temperature & Stress Relief over 1000°F** - (a)HTFM, (b)2-3700, (c)2-1900
 - Arc Gouging/Grinding** - (a)3000R, (b)2000G
- Determine dimensions of area to be protected
- Choose roll goods or size of finished blankets.

Temperature ratings are based on recommended usages and presented without guarantee or responsibility on our part. Information given herein is intended to be used as a guideline only.

As the industry leader in strip curtains, Wilson now offers our quality strip curtains in a made-to-order package. Just by following a few steps you can custom order curtains to fit your exact needs. Wilson products are designed to improve the overall working environment and increase productivity. All of our products meet or exceed OSHA specifications.

Easily pass into and out of noisy, hazardous or energy-wasting work areas. No struggling with heavy, awkward doors. Wilson See-Thru Strip Curtains automatically reseal with non-gap closure after pass through.

CLARITY Wilson clear vinyl strips allow added safety of a less obstructed view with outstanding clarity. Stabilizers added to the vinyl compound help reduce fading and yellowing.

ROUND EDGES Round edges help prevent snagging of products or clothes, with no sharp edges that harm personnel.

CONCAVE/CONVEX When hung, Wilson strips have a curved profile. By alternating and overlapping the strips, the opening has a built-in sealing ability, improving effectiveness.

STRONG/FLEXIBLE All Wilson vinyl products are available in a variety of thicknesses and widths to suit your applications.

Sound Transmission - Loss dB

| FREQUENCY | 80 MIL SHEET | 160 MIL SHEET |
|-----------|--------------|---------------|
| 100 HZ | 7 | 13 |
| 125 HZ | 8 | 14 |
| 160 HZ | 6 | 12 |
| 200 HZ | 4 | 10 |
| 250 HZ | 13 | 19 |
| 315 HZ | 13 | 19 |
| 400 HZ | 16 | 22 |
| 500 HZ | 17 | 23 |
| 630 HZ | 19 | 25 |
| 800 HZ | 20 | 26 |
| 1000 HZ | 22 | 28 |
| 1250 HZ | 23 | 29 |
| 3100 HZ | 30 | 36 |
| 4000 HZ | 31 | 37 |
| 5000 HZ | 33 | 39 |

FULL OVERLAP IS RECOMMENDED FOR MAXIMUM SOUND REDUCTION.

HOW TO ORDER IN A FEW EASY STEPS

1 Identify your safety and comfort needs.

Take a look at your whole work area. Are these areas that could be broken up in to specific stations?

- Welding, sanding, heavy traffic
- Temperature control to regulate wide fluctuation changes in temperature
- Refrigeration containment
- Dust control...storage areas for sensitive work areas

Now look at the shapes below and see if these can work for you. Enclosures and doors can be designed in any configuration and combination of: Beam Mount, Vertical Suspension, Wall Mount, Floor Mount, Automatic/Robotic.

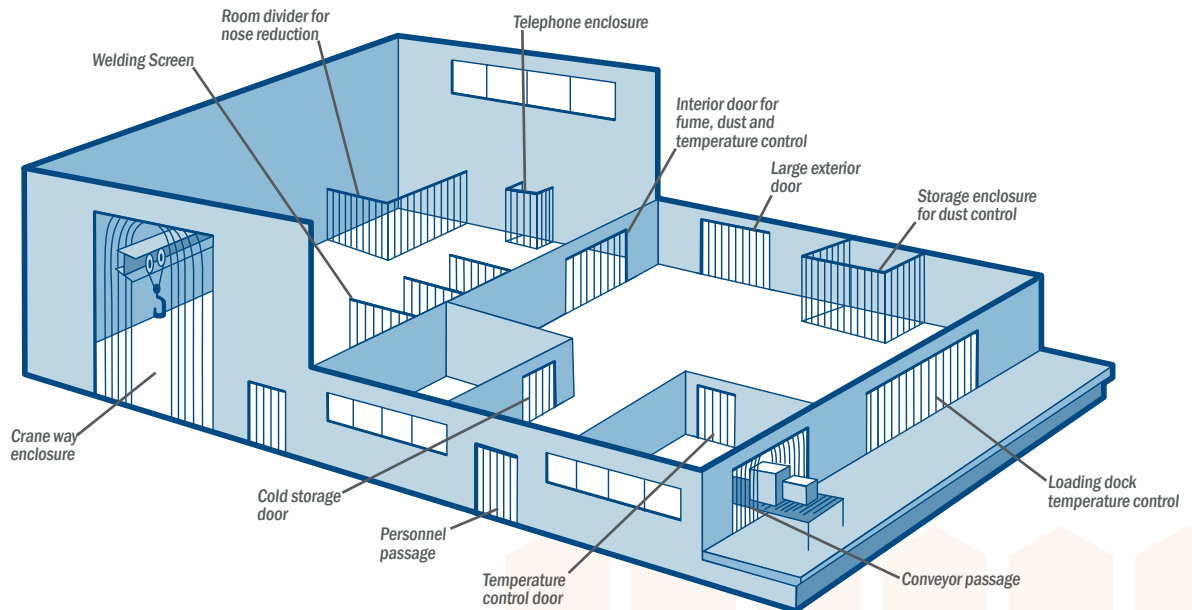
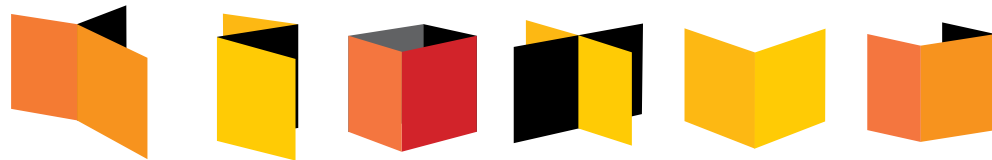

2

Sketch out your design and list the hardware components needed.

Sketch out the design you want and refer to that track hardware system to see all components offered.

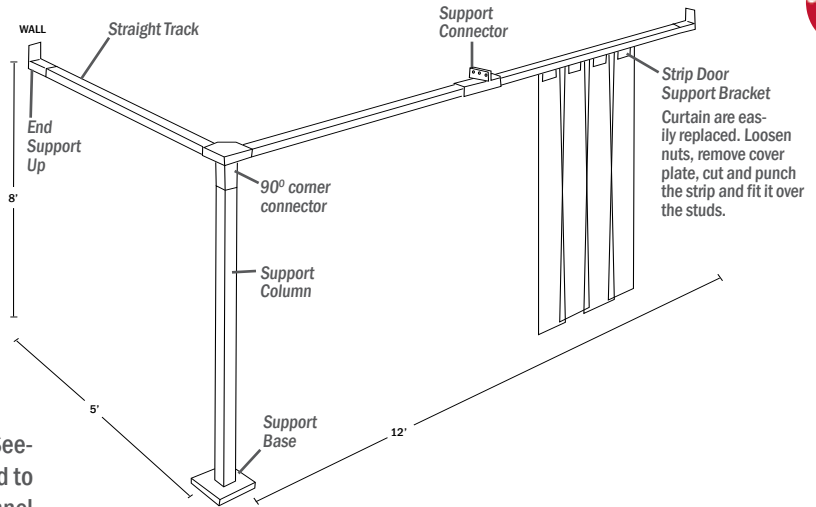

UNIVERSAL MOUNT

SUB100. 14 gauge, galvanized steel. Punched strips fit over studs welded to bracket and are secured in place with cover plates and nuts. Design allows Header Mount to overhead surface inside doorway, Wall Mount over doorway, or Threaded Rod. Call Customer Service at 1-800-423-4277 with dimensions.

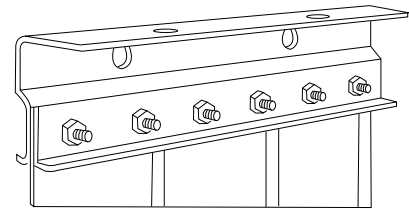

SB500 SUPPORT BRACKET/CHANNEL TRACK

One person can easily install or individually replace See-Thru Strip Curtains. They are hung on 1/4" studs welded to a support bracket which is inserted into a modular channel track. A sectionalized front bar is used to compress the strip material to the support bracket.

SB500 support brackets can be mounted to the ceiling, lintel bar, suspended from chain, cable, threaded rod, angle iron, or supported from the floor. Support brackets also integrate with Track Hardware on page XXX.

- Please specify exact lengths needed. Standard support spacing is approximately 5-7 feet.

3

Choose strip curtain for your specific application.

Considerations in choosing strip width, thickness and type of curtains:

1. How do I determine what size strip I need?

Wilson recommends using the following guidelines:

| DOOR HEIGHT | STRIP SIZE |
|----------------|---------------------|
| UP TO 8' HIGH | 6" - 40 MIL STRIP |
| 8' TO 10' | 8" - 80 MIL STRIP |
| 10' TO 12' | 12" - 120 MIL STRIP |
| 12' AND HIGHER | 16" - 160 MIL STRIP |

2. How do I determine the overlap I need?

A rule of thumb would be: If you have only pedestrian traffic, use a partial overlap. If you have forklift traffic, need protection from nose and /or temperatures, use a full overlap.

3. Do I need a ribbed or reinforced strip curtain?

You would only need the ribbed or reinforced strip if you have a high traffic area using pallet jacks, forklifts, highly abrasive materials, etc.

4. What if I need strips in a low temp or food grade area?

Wilson does offer both low temp and USDA approved strip materials.

5. Do the strip curtains offer light protection from Welding?

Wilson has strip curtains available in see-thru amber and spectra orange. These materials offer the same protection from dangerous UV radiation and arc glare as Wilson's innovative welding curtains and screens.

6. Do you want to order extra replacement strips?

Strip curtains are easily replaced. Just loosen nuts, remove cover plate, cut and punch the strip and fit it over the studs. All Wilson strip curtains are also sold in roll lengths. If you need to replace your strips it's great to have a roll around. You will just cut the length you need and replace any number of strip.

SEE-THRU STRIP CURTAIN MATERIAL, STRIP WIDTH, & THICKNESS

| | | | | |
|-----------------|-------|------|----------|----------|
| SEE-THRU CLEAR | 6" W | .040 | S666-40 | N/A |
| SEE-THRU CLEAR | 8" W | .080 | S850-40 | S810-40 |
| SEE-THRU CLEAR | 12" W | .120 | S1266-40 | S1210-40 |
| SEE-THRU CLEAR | 16" W | .160 | S1650-40 | S1610-40 |
| SEE-THRU AMBER | 6" W | .040 | S666-50 | N/A |
| SEE-THRU AMBER | 8" W | .080 | S850-50 | S810-50 |
| SEE-THRU AMBER | 12" W | .120 | S1266-50 | S1210-50 |
| SEE-THRU AMBER | 16" W | .160 | S1650-50 | S1610-50 |
| SEE-THRU ORANGE | 6" W | .040 | S666-25 | N/A |
| SEE-THRU ORANGE | 8" W | .080 | S850-25 | S810-25 |
| SEE-THRU ORANGE | 12" W | .120 | S1266-25 | S1210-25 |

PARTIAL OVERLAP

PART NO

FULL OVERLAP

PART NO

*1/2" OVERLAP FOR 8" AND 16" STRIPS, 2/3" OVERLAP FOR 6" AND 12" STRIPS USDA, REINFORCED OR RIBBED MATERIALS AVAILABLE. CONTACT FACTORY FOR PRICE.

REPLACEMENT STRIPS MATERIAL, STRIP WIDTH, & THICKNESS

| | | | | |
|-----------------|-------|------|---------------|----------|
| SEE-THRU CLEAR | 6" W | .040 | 62 LBS, 300' | S406-40 |
| SEE-THRU CLEAR | 8" W | .080 | 100 LBS, 300' | S808-40 |
| SEE-THRU CLEAR | 12" W | .120 | 150 LBS, 200' | S1212-40 |
| SEE-THRU CLEAR | 16" W | .160 | 200 LBS, 150' | S1610-40 |
| SEE-THRU AMBER | 6" W | .040 | 62 LBS, 300' | S406-50 |
| SEE-THRU AMBER | 8" W | .080 | 100 LBS, 300' | S808-50 |
| SEE-THRU AMBER | 12" W | .120 | 150 LBS, 200' | S1212-50 |
| SEE-THRU AMBER | 16" W | .160 | 200 LBS, 150' | S1610-50 |
| SEE-THRU ORANGE | 6" W | .040 | 62 LBS, 300' | S406-25 |
| SEE-THRU ORANGE | 8" W | .080 | 100 LBS, 300' | S808-25 |
| SEE-THRU ORANGE | 12" W | .120 | 150 LBS, 200' | S1212-25 |

APPROX. WEIGHT & FT PER ROLL

PART NO

| | |
|---------------|----------|
| 62 LBS, 300' | S406-40 |
| 100 LBS, 300' | S808-40 |
| 150 LBS, 200' | S1212-40 |
| 200 LBS, 150' | S1610-40 |
| 62 LBS, 300' | S406-50 |
| 100 LBS, 300' | S808-50 |
| 150 LBS, 200' | S1212-50 |
| 200 LBS, 150' | S1610-50 |
| 62 LBS, 300' | S406-25 |
| 100 LBS, 300' | S808-25 |
| 150 LBS, 200' | S1212-25 |

TRACK HARDWARE SYSTEM

Wilson's track hardware system forms quick, economical walls at a fraction of the cost of standard construction. Break up large areas into smaller compartments for safety, privacy and convenience. Track Hardware moves on quiet nylon rollers set in steel track. All components are hot-dipped galvanized or zinc plated to prevent rusting.

Available in five suspension methods (may be used in any combination): Beam/Vertical Suspension, Wall Mounting, Ceiling Mounting, Floor Mounting or Thread Rod Mounting

HOW TO ORDER

The experts in customer service at Wilson Industries can help you design work areas within a space using the Wilson Track Hardware System. You can be sure that layout of the space, the suspension method and connectors they suggest are the best for your application.



1. Determine dimension of each side
2. Choose suspension system
3. Order all necessary parts based on
 - A. suspension system B. type of corners (deduct 2 feet from adjacent track sections for curved corner)
 - C. length of sides (sides should be supported at maximum 10' intervals)
4. Select Wilson fabric and order curtains). Add 10% to width for proper drape. Specify height and width.

Note: Wilson Track Hardware is shipped disassembled. Nuts and bolts not included.

COMPONENTS

| | | | | | |
|---|---|--|--|---|---|
|  STRIP DOOR SUPPORT BRACKET (4" LONG) 21132 |  HINGED STRIP DOOR TROLLEY 21130 |  PULL ROPE WITH BRACKET 21131 |  STRAIGHT TRACK 5 FEET 21101-5 6 FEET 21101-6 7 FEET 21101-7 8 FEET 21101-8 9 FEET 21101-9 10 FEET 21101-10 SPECIAL LENGTHS AVAILABLE UPON REQUEST (20 FEET MAXIMUM) | | |
|  STRAIGHT CONNECTOR 211102 |  END STOP 21103 |  SUPPORT CONNECTOR 21104 |  END SUPPORT UP 21105 |  END SUPPORT DOWN 21106 |  OVERLAPPING TROLLEY 21129 |

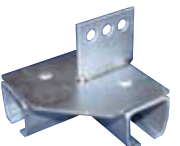

BEAM MOUNTED

| | | | | | | |
|---|--|---|--|---|--|--|
|  SUPPORT CONNECTOR 21115 |  90° CORNER CONNECTOR 21116 |  3-WAY T-CONNECTOR 21117 |  THREADED ROD SUPPORT CONNECTOR 21135 |  SUPPORT COLUMN 6 FEET 21124 7 FEET 21125 8 FEET 21126 |  90° CURVE/24" R (3 SUPPORTS) 21114 |  THREADED ROD ADAPTER 21134 |
|---|--|---|--|---|--|--|

FLOOR MOUNTED

| | | | | |
|---|--|---|---|---|
|  SUPPORT CONNECTOR 21120 |  90° CORNER CONNECTOR 21121 |  3 WAY T-CONNECTOR 21122 |  SUPPORT BASE 21127 |  90° CURVE/24" R 21119 |
|---|--|---|---|---|

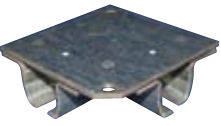
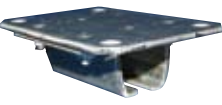
CEILING MOUNTED

| | | |
|--|---|---|
|  90° CORNER CONNECTOR 21110 |  SUPPORT CONNECTOR 21109 |  90° CURVE/24" R (3 SUPPORTS) 21108 |
|--|---|---|

2 WAY ROLLER

| | |
|---|---|
|  STEEL WHEEL 21133 |  NYLON WHEEL 21128 |
|---|---|

CURTAIN WALLS



Wilson Curtain Walls offer the most economical solution for the segmentation of a facility. The multi-task environments demand the most efficient utilization of floor space. The thoughtful separation of functions such as metal repair, welding, body prep, washing or detailing can add productivity to your operation.



Wall Curtain Systems combine the highest quality opaque and clear vinyl materials with the integrity of high tensile steel roller track and hardware parts to deliver the finest wall curtain product available. Our curtains are electronically sealed, not sewn, to assure a strong seam for long service life. The side seams are reinforced for strength and the ballast chain weight is secured in a secondary containment hem pocket for added durability. The two-wheel roller hooks assure a smooth action for easy movement of the curtains.

Curtain designs are available in floor-mounted configurations, as well as ceiling suspended styles or flush mounted to prep station or other framework. Curtains are available in a variety of color combinations for a custom coordinated look.

Contact Customer Service for more information at 1-800-423-4277.

TIE-DOWN STRAPS

Replaceable straps and flush mounting D-ring hardware comprise the tie-down accessory package. Easily attached to the curtain, tie-downs prevent unnecessary curtain movement in draft prone work areas.



| DESCRIPTION | PART # |
|----------------|--------|
| TIE-DOWN STRAP | TD-15 |

ANTI-FATIGUE SPATTER MAT



The ultimate anti-fatigue mat for welding areas! The Spatter-Mat's specially formulated rubber surface repels sparks and hot metal shards. Designed for worker comfort, the buoyant sponge base alleviates leg and back stress and minimizes overall body fatigue. Edges are beveled for safety. 1/2" overall thickness. Pebbled surface also provides extra traction in industrial areas.

| PART # | DESCRIPTION |
|----------------------------------|-------------|
| 2306-SM | 2' X 3' |
| 3515-SM | 3' X 5' |
| CUSTOM SIZES UP TO 75' IN LENGTH | |

STRESS RELIEF PADS

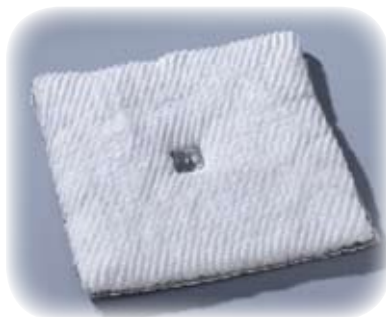

Flexible pads made from special non-asbestos, resilient, high temperature materials. Non-combustible & chemically inert, provides temporary insulation of welds during stress relieving of large diameter piping.

| PART # | DESCRIPTION |
|--------|--------------------|
| HTFM | STRESS RELIEF PADS |

STAINLESS STEEL SAFETY MESH



Used as a machine guard to protect personnel and equipment from high velocity flying chips or shrapnel, such as broken carbide cutters and grinding wheels, or large cuts of metal. Excellent as a protective screen around mills, routers, spar mills, lathe, grinders and forges, and as a safety barrier for various types of testing applications.

Stainless steel Safety Mesh is secured at the top and hangs free at both sides and bottom. Safety Mesh not only stops dangerous flying debris, but also protects those within the confines of the work area. Upon contact, the Safety Mesh wraps around the debris and drops it onto the floor, preventing it from leaving the work area or ricocheting back toward the machine operator. Allows for good visibility and airflow into the protected work environment.

- Fire resistant
- Will not absorb oil
- Easily cleaned

For maximum chip protection, mesh should have 50% additional drape or fullness. Mesh should have 100% additional drape for test applications

DESCRIPTION

1/8" - 19 GAUGE STAINLESS STEEL MESH (100 LBS/SQ FT)
 3/16" - 19 GAUGE STAINLESS STEEL MESH (80 LBS/SQ FT)

PART #

SSM018
 SSM316

*PLEASE SPECIFY WIDTH AND HEIGHT WHEN ORDERING. (BE SURE TO INCLUDE PROPER DRAPE.) MINIMUM HEIGHT 2 FEET - MAXIMUM HEIGHT 20 FEET

wilsonindustries



STAINLESS STEEL MESH HOOKS

Each hook "locks in" three strands of steel mesh, creating full draping effect which surrounds flying objects on impact. Should be placed on 3" centers.

DESCRIPTION

FITS OVER 1" STANDARD PIPE - DEDUCT 2" ON OVERALL HEIGHT
 FITS OVER 1.5" STANDARD PIPE - DEDUCT 3" ON OVERALL HEIGHT

PART #

1516
 2000

STAINLESS STEEL MESH WITH STUR-D-SCREEN

3/16" - 19 gauge mesh with 50% drape. Free standing frame of sturdy square steel tubing. Easy to assemble. 1/8" - 19 gauge and/or additional drape available.

FRAME SIZE SINGLE PANEL

5' X 5'
 5' X 6'
 5' X 7'
 5' X 8'
 6' X 6'
 6' X 7'
 6' X 8'

PART #

R1055-SSM
 R1056-SSM
 R1057-SSM
 R1058-SSM
 R1066-SSM
 R1067-SSM
 R1068-SSM

FRAME SIZE TWO PANEL

5' X 5'
 5' X 6'
 5' X 7'
 5' X 8'
 6' X 6'
 6' X 7'
 6' X 8'

PART #

R2055-SSM
 R2056-SSM
 R2057-SSM
 R2058-SSM
 R2066-SSM
 R2067-SSM
 R2068-SSM

FRAME SIZE THREE PANEL

5' X 5'
 5' X 6'
 5' X 7'
 5' X 8'
 6' X 6'
 6' X 7'
 6' X 8'

PART #

R3055-SSM
 R3056-SSM
 R3057-SSM
 R3058-SSM
 R3066-SSM
 R3067-SSM
 R3068-SSM

Wilson applied the knowledge gained by the military in impact physics, tank armor design and projectile impact science when developing their unique Stainless Steel Safety Mesh.

Boeing engineers used **Wilson Stainless Steel Mesh** when they pressure tested an aircraft. The stainless steel mesh was wrapped around the entire aircraft. It safely captured the flying debris when the wing ruptured, dropping the shrapnel harmlessly to the ground.



FLAMESHIELD

SOLDERING & WELDING PAD

Protects walls, joints and wall studs from burn damage associated with low temperature soldering. Also an excellent blanket for weld sparks and spatter. Flameshield is a must for every toolbox and maintenance service vehicle. Made of Wilson Weld-O-Glass 906 fabric. One grommet in each of the top corners.



| DESCRIPTION | PART NO |
|-----------------------------|-------------|
| 9" X 12" COATED FIBERGLASS | 912FS |
| 18" X 20" COATED FIBERGLASS | 1820FS |
| 9" X 12" CARBON FELT | 912FS-5180 |
| 18" X 20" CARBON FELT | 1820FS-5180 |

BACK HAND PAD

ALUMINIZED WELD--O-GLASS

Protects the back of welder's glove from weld spatter and high radiant heat. Increases the life of your glove. Helps you to weld longer when exposed to high radiant heat. Provides good mobility for gloved hand. Double layer protection, Wilson Weld-O-Glass 2600 AMA on top and a high temperature glass fabric on the bottom. Sewn and riveted for added durability.



| DESCRIPTION | STOCK ITEM | PART NO |
|------------------------------|------------|---------|
| BACK HAND PAD (MIN. ORDER 6) | 3018810 | BHP06 |

ELECTRO-SAFE ANTI-STATIC

SEE-THRU VINYL CURTAIN

A SUPERIOR ANTI-STATIC, See-Thru vinyl curtain. A carbon scrim grounds out electrical charges, bringing the curtain down to zero voltage. Static free, ideal anywhere a dust-free environment is vital. Fire retardant.



Contact customer service for ordering information at 800-423-4277

WELDING UMBRELLA



Provides great protection from rain or sunlight. Features a lightweight aluminum frame and tilt mechanism. Cover made of fire retardant, Rip-Stop vinyl for water and tear resistance.

| PART # | DESCRIPTION |
|--------|-------------------|
| UM6500 | BLUE |
| UM8500 | YELLOW |
| UM9500 | GREEN |
| UB750 | RED, WHITE & BLUE |



trafficsafety



PROTECTING OUR ROAD WARRIORS

For work zone related safety products, Jackson Safety is truly the most complete safety solution.

In the area of temporary traffic control, we provide high visibility safety products that not only meet or exceed federal and state standards, but offer solutions for motorists and pedestrians in both high speed and low speed work zones.

Worker safety and visibility is the ultimate goal in the Jackson Safety line of Road Warrior safety apparel. This quality line of apparel combines comfort and breathability in garments with a high degree of visibility that meets ANSI/ISEA requirements and provides workers with full 360° visibility in all types of light and weather conditions.

As the leading manufacturer of traffic cones, Jackson Safety offers the broadest array of products in the industry and provides custom stenciling for high visibility identification.

Whether the work zone specifications call for barricades, cones, channelizers, roll-up signs, sign stands or a broad variety of other highway and traffic safety products, Jackson Safety has the experience and the products that are necessary to provide a complete solution for every need.

In a broad sense, traffic control for Jackson Safety also means crowd management in non-highway settings, such as public buildings, restaurants, and other venues, where maintenance and control products such as floor cones become a necessity. The Jackson line of products, with its long standing Lamba® line, meets and exceeds this need.





STANDARDS

ANSI 107: The American National Standards Institute (ANSI) publishes a regulatory safety standard for high visibility clothing. The standard defines three classes of successively more visible garments that protect workers exposed to increasingly higher levels of risk from motor vehicles and heavy equipment.

MUTCD: The Manual on Uniform Traffic Control Devices (MUTCD) is a document issued by the Federal Highway Administration (FHWA) of the United States Department of Transportation (USDOT) to specify the standards by which traffic signs, road markings, and signals are designed, installed and used. These specifications include the shapes, colors, and fonts used in road markings and signs. All of Jackson Safety's traffic products meet MUTCD standards.

NCHRP 350: The National Cooperative Highway Research Program (NCHRP) represents uniform guidelines for conducting full-scale crash tests for permanent and temporary highway safety features. The crash performance is judged on structural adequacy, occupant risk and vehicle trajectory. Products addressed in these guidelines include longitudinal barriers, transitions, end terminals, crash cushions, breakaway/yielding supports, truck mounted attenuators and work zone traffic control devices. All of Jackson Safety's traffic products meet or exceed NCHRP 350 regulations.

ITE: The Institute of Transportation Engineers (ITE) is an international educational and scientific association of transportation professionals who attempt to meet mobility and safety standards. ITE facilitates the application of technology and scientific principles to research, plan, functional design, implementation, operation, policy development and management for any mode of transportation. Jackson Safety's line of barricade lights have all been awarded ITE certification.

FMVSS 125: Federal Motor Vehicle Safety Standards (FMVSS) is a standard that applies to the shape, size, and performance requirements for reusable day and night warning devices that can be erected on or near the roadway to warn approaching motorists of the presence of a stopped vehicle. Our safety triangles conform to FMVSS standards.

OSHA: Occupational Safety and Health Administration (OSHA) is a division of the United States Department of Labor. Their mission is to prevent work-related injuries, illnesses and deaths by issuing and enforcing standards for workplace safety and health.

ISEA: The International Safety Equipment Association (ISEA) is the primary trade association in the U.S. for companies that manufacture safety and personal protective equipment. The member companies are world leaders in the design and manufacturing of protective clothing and equipment used in factories, construction sites, hospitals, clinics, farms, schools, laboratories, emergency response and in the home.



Our Road Warriors are the men and women of the road construction industry that work long hours, in all conditions to improve our daily lives. As a tribute to these Warriors, Jackson Safety is proud to offer a complete line of ANSI approved safety vests, t-shirts, rain wear and winter apparel. These products were designed with them in mind because we understand the need for durable safety equipment that is tough enough to keep up with any job site.

WHAT IS ANSI/ISEA 107-2004?

ANSI/ISEA 107-2004 is a voluntary consensus standard for high visibility safety apparel. ANSI/ISEA 107 represents what the industry views as necessary to adequately protect workers from the hazards associated with low visibility. OSHA set forth requirements in regulation 29 CFR 1926.6(d), that “employees exposed to public vehicular traffic shall be provided with, and shall wear, warning vests or suitable garments marked with or made of reflectorized or high-visibility safety material.”

Four classes of safety garments are offered for high visibility protection.



ANSI Class 1 garments are generally used for workers in occupations that permit full and undivided attention to approaching traffic, when work backgrounds are not complex and when pedestrian workers are separated from traffic.



ANSI Class 2 garments are generally used for workers in occupations that require greater visibility under inclement weather conditions, when work backgrounds are complex and when tasks divert the workers attention from approaching vehicle traffic.



ANSI Class 3 garments are generally used for workers and vehicle operators whose high task loads place them in danger, when the wearer must be identifiable as a person and when the wearer must be conspicuous through the full range of body motions at a minimum of 1,280 feet.



ANSI Class E is the only standard that is specific to hi-visibility pants and are generally used for workers and vehicle operators whose occupations require full head-to-toe visibility and/or when work backgrounds are complex. The worker is required to combine the Class E garment with a Class 2 or Class 3 garment.

SCREEN PRINTING FOR APPAREL

Jackson Safety will customize apparel at your request. Supplying camera-ready artwork benefits you by avoiding any additional fees and longer lead times. Below is a listing of all of our apparel that can be screen printed. We can print on any size, as the sizes increase (from size large), the back width increases 1/2" for each size up and decreases 1/2" for each size down.

Customizing your vest is easy!

1. Contact our customer service team at (800) 428-8185 to order.
2. Minimum order of 10 vests that are the same style (different sizes of that style may be ordered).
3. There is a 2 week lead time after the customer approval of artwork.

| Description | Printing Dimensions (BACK) | Printing Dimensions (FRONT) |
|--|-----------------------------------|-----------------------------------|
| ANSI Class 1 Vest - Deluxe, Solid, L | 11.5"W X 10"H | 3"W X 3"H right side only |
| ANSI Class 1 Vest - Standard, Solid, L | 13.5"W X 10"H | 3"W X 3"H right side only |
| ANSI Class 1 Vest - Deluxe, Mesh, L | 11"W X 10"H | 3"W X 3"H right side only |
| ANSI Class 1 Vest - Standard, Mesh, L | 12"W X 10"H | 3"W X 3"H right side only |
| ANSI Class 2 Vest - Two Tone, L * | 7"W X 7"H | N/A |
| ANSI Class 2 Vest - Deluxe, Solid, L | 11.5"W X 10"H | 3"W X 3"H right side only |
| ANSI Class 2 Vest - Standard, Solid, L | 11"W X 10"H | 3"W X 3"H right side only |
| ANSI Class 2 Vest - Deluxe, Mesh, L | 11"W X 10"H | 3"W X 3"H right side only |
| ANSI Class 2 Vest - Standard, Mesh, L | 11"W X 10"H | 3"W X 3"H right side only |
| ANSI Class 3 Vest - Deluxe, Solid, L | 12"W X 10"H | 3"W X 3"H right side only |
| ANSI Class 3 Vest - Standard, Solid, L | 14"W X 10"H | 3"W X 3"H right side only |
| ANSI Class 3 Vest - Deluxe, Mesh, L | 12"W X 10"H | 3"W X 3"H right side only |
| ANSI Class 3 Vest - Standard, Mesh, L | 15"W X 10"H | 3"W X 3"H right side only |
| ANSI Class 2 T-shirt, L | 12"W X 10"H | 7"W X 7"H |
| ANSI Class 3 T-shirt, L | 12"W X 10"H | 7"W X 7"H |
| CoolDRY High Performance T-shirt, L | 14"W X 10"H | CALL CUSTOMER SERVICE FOR DETAILS |
| Rainwear, Sweatshirts, Winter Apparel | CALL CUSTOMER SERVICE FOR DETAILS | |

*On all of the ANSI Class 2 Two-Tone Vests, the screen printing dimensions do not increase with size changes.



Available in durable, breathable, certified mesh and solid materials

ALL OF OUR ANSI VESTS ARE AVAILABLE IN DELUXE OR STANDARD STYLES WITH A MESH OR SOLID FABRIC.

Available with hook and loop or zipper closures

ANSI CLASS 3 SAFETY VESTS

360° visibility with reflective tape. Machine washable.

5X and 6X sizes available. Please contact Customer Service for more details.

DELUXE STYLE

4 pocket design. Rugged color matched front zipper closure. Durable material with mesh or solid options. Silver bead or color prismatic reflective tape.



Close up of zipper closure



Shown #3009982
DELUXE MESH

DESCRIPTION

DELUXE SOLID
 ORANGE WITH LIME PRISMATIC - M
 ORANGE WITH LIME PRISMATIC - L
 ORANGE WITH LIME PRISMATIC - XL
 ORANGE WITH LIME PRISMATIC - 2X
 ORANGE WITH LIME PRISMATIC - 3X
 ORANGE WITH LIME PRISMATIC - 4X
 LIME WITH LIME PRISMATIC - M
 LIME WITH LIME PRISMATIC - L
 LIME WITH LIME PRISMATIC - XL
 LIME WITH LIME PRISMATIC - 2X
 LIME WITH LIME PRISMATIC - 3X
 LIME WITH LIME PRISMATIC - 4X

PART

3009956 [9131001]
 3009957 [9131002]
 3009958 [9131003]
 3009959 [9131004]
 3009960 [9131005]
 3009961 [9131006]
 3009962 [9131011]
 3009963 [9131012]
 3009964 [9131013]
 3009965 [9131014]
 3009966 [9131015]
 3009967 [9131016]

DELUXE MESH

ORANGE WITH SILVER REFLECTIVE - M
 ORANGE WITH SILVER REFLECTIVE - L
 ORANGE WITH SILVER REFLECTIVE - XL
 ORANGE WITH SILVER REFLECTIVE - 2X
 ORANGE WITH SILVER REFLECTIVE - 3X
 ORANGE WITH SILVER REFLECTIVE - 4X
 LIME WITH SILVER REFLECTIVE - M
 LIME WITH SILVER REFLECTIVE - L
 LIME WITH SILVER REFLECTIVE - XL
 LIME WITH SILVER REFLECTIVE - 2X
 LIME WITH SILVER REFLECTIVE - 3X
 LIME WITH SILVER REFLECTIVE - 4X

3009980 [9131201]
 3009981 [9131202]
 3009982 [9131203]
 3009983 [9131204]
 3009984 [9131205]
 3009985 [9131206]
 3009986 [9131211]
 3009987 [9131212]
 3009988 [9131213]
 3009989 [9131214]
 3009990 [9131215]
 3009991 [9131216]

STANDARD STYLE

Hook and loop front closure. Silver bead reflective tape.



Close up of hook & loop closure



Shown #3010000
STANDARD MESH

DESCRIPTION

STANDARD MESH
 ORANGE WITH SILVER REFLECTIVE - M
 ORANGE WITH SILVER REFLECTIVE - L
 ORANGE WITH SILVER REFLECTIVE - XL
 ORANGE WITH SILVER REFLECTIVE - 2X
 ORANGE WITH SILVER REFLECTIVE - 3X
 ORANGE WITH SILVER REFLECTIVE - 4X
 LIME WITH SILVER REFLECTIVE - M
 LIME WITH SILVER REFLECTIVE - L
 LIME WITH SILVER REFLECTIVE - XL
 LIME WITH SILVER REFLECTIVE - 2X
 LIME WITH SILVER REFLECTIVE - 3X
 LIME WITH SILVER REFLECTIVE - 4X

PART

3009992 [9131301]
 3009993 [9131302]
 3009994 [9131303]
 3009995 [9131304]
 3009996 [9131305]
 3009997 [9131306]
 3009998 [9131311]
 3009999 [9131312]
 3010000 [9131313]
 3010001 [9131314]
 3010002 [9131315]
 3010003 [9131316]

ANSI CLASS 2 SAFETY VESTS

360° visibility with reflective tape. Machine washable.

5X and 6X sizes available. Please contact Customer Service for more details.

DELUXE STYLE

4 pocket design. Rugged color matched front zipper closure. Durable material with mesh or solid options. Silver bead or color prismatic reflective tape.



ANSI CLASS 2

Shown #3009932
DELUXE MESH

| DESCRIPTION | PART # |
|------------------------------------|-------------------|
| DELUXE SOLID | |
| ORANGE WITH LIME PRISMATIC - M | 3009894 [9121001] |
| ORANGE WITH LIME PRISMATIC - L | 3009895 [9121002] |
| ORANGE WITH LIME PRISMATIC - XL | 3009896 [9121003] |
| ORANGE WITH LIME PRISMATIC - 2X | 3009897 [9121004] |
| ORANGE WITH LIME PRISMATIC - 3X | 3009898 [9121005] |
| ORANGE WITH LIME PRISMATIC - 4X | 3009899 [9121006] |
| LIME WITH ORANGE PRISMATIC - M | 3009900 [9121011] |
| LIME WITH ORANGE PRISMATIC - L | 3009901 [9121012] |
| LIME WITH ORANGE PRISMATIC - XL | 3009902 [9121013] |
| LIME WITH ORANGE PRISMATIC - 2X | 3009903 [9121014] |
| LIME WITH ORANGE PRISMATIC - 3X | 3009904 [9121015] |
| LIME WITH ORANGE PRISMATIC - 4X | 3009905 [9121016] |
| DELUXE MESH | |
| ORANGE WITH SILVER REFLECTIVE - M | 3009930 [9121201] |
| ORANGE WITH SILVER REFLECTIVE - L | 3009931 [9121202] |
| ORANGE WITH SILVER REFLECTIVE - XL | 3009932 [9121203] |
| ORANGE WITH SILVER REFLECTIVE - 2X | 3009933 [9121204] |
| ORANGE WITH SILVER REFLECTIVE - 3X | 3009934 [9121205] |
| ORANGE WITH SILVER REFLECTIVE - 4X | 3009935 [9121206] |
| LIME WITH SILVER REFLECTIVE - M | 3009936 [9121211] |
| LIME WITH SILVER REFLECTIVE - L | 3009937 [9121212] |
| LIME WITH SILVER REFLECTIVE - XL | 3009938 [9121213] |
| LIME WITH SILVER REFLECTIVE - 2X | 3009939 [9121214] |
| LIME WITH SILVER REFLECTIVE - 3X | 3009940 [9121215] |
| LIME WITH SILVER REFLECTIVE - 4X | 3009941 [9121216] |

STANDARD STYLE

Hook and loop front closure. Silver bead reflective tape.



ANSI CLASS 2

Shown #3009920
STANDARD SOLID

Shown above #3009951
STANDARD MESH

| DESCRIPTION | PART # |
|------------------------------------|-------------------|
| STANDARD SOLID | |
| ORANGE WITH SILVER REFLECTIVE - M | 3009918 [9121101] |
| ORANGE WITH SILVER REFLECTIVE - L | 3009919 [9121102] |
| ORANGE WITH SILVER REFLECTIVE - XL | 3009920 [9121103] |
| ORANGE WITH SILVER REFLECTIVE - 2X | 3009921 [9121104] |
| ORANGE WITH SILVER REFLECTIVE - 3X | 3009922 [9121105] |
| ORANGE WITH SILVER REFLECTIVE - 4X | 3009923 [9121106] |
| LIME WITH SILVER REFLECTIVE - M | 3009924 [9121111] |
| LIME WITH SILVER REFLECTIVE - L | 3009925 [9121112] |
| LIME WITH SILVER REFLECTIVE - XL | 3009926 [9121113] |
| LIME WITH SILVER REFLECTIVE - 2X | 3009927 [9121114] |
| LIME WITH SILVER REFLECTIVE - 3X | 3009928 [9121115] |
| LIME WITH SILVER REFLECTIVE - 4X | 3009929 [9121116] |
| STANDARD MESH | |
| ORANGE WITH SILVER REFLECTIVE - M | 3009944 [9121301] |
| ORANGE WITH SILVER REFLECTIVE - L | 3009945 [9121302] |
| ORANGE WITH SILVER REFLECTIVE - XL | 3009946 [9121303] |
| ORANGE WITH SILVER REFLECTIVE - 2X | 3009947 [9121304] |
| ORANGE WITH SILVER REFLECTIVE - 3X | 3009948 [9121305] |
| ORANGE WITH SILVER REFLECTIVE - 4X | 3009949 [9121306] |
| LIME WITH SILVER REFLECTIVE - M | 3009950 [9121311] |
| LIME WITH SILVER REFLECTIVE - L | 3009951 [9121312] |
| LIME WITH SILVER REFLECTIVE - XL | 3009952 [9121313] |
| LIME WITH SILVER REFLECTIVE - 2X | 3009953 [9121314] |
| LIME WITH SILVER REFLECTIVE - 3X | 3009954 [9121315] |
| LIME WITH SILVER REFLECTIVE - 4X | 3009955 [9121316] |

ANSI CLASS 2 TWO-TONE SAFETY VESTS

360° visibility with reflective tape. Machine washable.

6X - 9X size available. Please contact Customer Service for more details.

DELUXE STYLE

3 pocket design. Rugged color matched front zipper closure. Adjustable panel-belt system for tailored fit over bulky clothes.

Shown #3012873
DELUXE SOLID



ANSI CLASS 2

Shown #3012876
DELUXE MESH

| DESCRIPTION | PART # |
|--------------------------------------|---------|
| DELUXE SOLID | |
| ORANGE WITH SILVER OVER LIME - M-XL | 3012870 |
| ORANGE WITH SILVER OVER LIME - 2X-5X | 3012872 |
| LIME WITH SILVER OVER ORANGE - M-XL | 3012873 |
| LIME WITH SILVER OVER ORANGE - 2X-5X | 3012874 |
| DELUXE MESH | |
| ORANGE WITH SILVER OVER LIME - M-XL | 3012875 |
| ORANGE WITH SILVER OVER LIME - 2X-5X | 3012876 |
| LIME WITH SILVER OVER ORANGE - M-XL | 3012877 |
| LIME WITH SILVER OVER ORANGE - 2X-5X | 3012878 |

STANDARD STYLE

Hook and loop front closure. Easily expands to fit over bulky clothes.

Shown #3012881
STANDARD SOLID



ANSI CLASS 2

Shown #3012883
STANDARD MESH

| DESCRIPTION | PART # |
|--------------------------------------|---------|
| STANDARD SOLID | |
| ORANGE WITH LIME OVER SILVER - M-XL | 3012879 |
| ORANGE WITH LIME OVER SILVER - 2X-5X | 3012880 |
| LIME WITH ORANGE OVER SILVER - M-XL | 3012881 |
| LIME WITH ORANGE OVER SILVER - 2X-5X | 3012882 |
| STANDARD MESH | |
| ORANGE WITH LIME OVER SILVER - M-XL | 3012883 |
| ORANGE WITH LIME OVER SILVER - 2X-5X | 3012884 |
| LIME WITH ORANGE OVER SILVER - M-XL | 3012885 |
| LIME WITH ORANGE OVER SILVER - 2X-5X | 3012886 |

safety apparel



ANSI CLASS 1 SAFETY VESTS

360° visibility with reflective tape. Machine washable.

DELUXE STYLE

4 pocket design. Rugged color matched front zipper closure. Durable material with mesh or solid options. Silver bead or color prismatic reflective tape.

Shown #3009847
DELUXE SOLID



Shown #3009872
DELUXE MESH



| DESCRIPTION | PART # | |
|------------------------------------|---------|-----------|
| DELUXE SOLID | | |
| ORANGE WITH WHITE PRISMATIC - M | 3009833 | [9111001] |
| ORANGE WITH WHITE PRISMATIC - L | 3009834 | [9111002] |
| ORANGE WITH WHITE PRISMATIC - XL | 3009835 | [9111003] |
| ORANGE WITH WHITE PRISMATIC - 2X | 3009836 | [9111004] |
| ORANGE WITH WHITE PRISMATIC - 3X | 3009837 | [9111005] |
| ORANGE WITH WHITE PRISMATIC - 4X | 3009838 | [9111006] |
| LIME WITH WHITE PRISMATIC - M | 3009845 | [9111021] |
| LIME WITH WHITE PRISMATIC - L | 3009846 | [9111022] |
| LIME WITH WHITE PRISMATIC - XL | 3009847 | [9111023] |
| LIME WITH WHITE PRISMATIC - 2X | 3009848 | [9111024] |
| LIME WITH WHITE PRISMATIC - 3X | 3009849 | [9111025] |
| LIME WITH WHITE PRISMATIC - 4X | 3009850 | [9111026] |
| DELUXE MESH | | |
| ORANGE WITH SILVER REFLECTIVE - M | 3009870 | [9111201] |
| ORANGE WITH SILVER REFLECTIVE - L | 3009871 | [9111202] |
| ORANGE WITH SILVER REFLECTIVE - XL | 3009872 | [9111203] |
| ORANGE WITH SILVER REFLECTIVE - 2X | 3009873 | [9111204] |
| ORANGE WITH SILVER REFLECTIVE - 3X | 3009874 | [9111205] |
| ORANGE WITH SILVER REFLECTIVE - 4X | 3009875 | [9111206] |
| LIME WITH SILVER REFLECTIVE - M | 3009876 | [9111211] |
| LIME WITH SILVER REFLECTIVE - L | 3009877 | [9111212] |
| LIME WITH SILVER REFLECTIVE - XL | 3009878 | [9111213] |
| LIME WITH SILVER REFLECTIVE - 2X | 3009879 | [9111214] |
| LIME WITH SILVER REFLECTIVE - 3X | 3009880 | [9111215] |
| LIME WITH SILVER REFLECTIVE - 4X | 3009881 | [9111216] |

FLAME RETARDANT SAFETY VESTS

All material and reflective tape meets NFPA 701 standards.



DELUXE ANSI CLASS 3

Zipper closure. Red prismatic tape. 4 pockets, 2 outside and 2 inside. Flame retardant



STANDARD ANSI CLASS 2

Hook and loop closure. Silver bead reflective tape. Flame retardant.



ECONOMY NON-ANSI

Hook and loop closure. Unique 2 sizes fits most system. Flame retardant.

| DESCRIPTION | PART # |
|---------------------------------|---------|
| LIME WITH ORANGE PRISMATIC - M | 3015105 |
| LIME WITH ORANGE PRISMATIC - L | 3015106 |
| LIME WITH ORANGE PRISMATIC - XL | 3015107 |
| LIME WITH ORANGE PRISMATIC - 2X | 3015108 |
| LIME WITH ORANGE PRISMATIC - 3X | 3015109 |
| LIME WITH ORANGE PRISMATIC - 4X | 3015110 |
| LIME WITH ORANGE PRISMATIC - 5X | 3015111 |
| LIME WITH ORANGE PRISMATIC - 6X | 3015112 |

| DESCRIPTION | PART # |
|----------------------------------|---------|
| LIME WITH SILVER REFLECTIVE - M | 3015097 |
| LIME WITH SILVER REFLECTIVE - L | 3015098 |
| LIME WITH SILVER REFLECTIVE - XL | 3015099 |
| LIME WITH SILVER REFLECTIVE - 2X | 3015100 |
| LIME WITH SILVER REFLECTIVE - 3X | 3015101 |
| LIME WITH SILVER REFLECTIVE - 4X | 3015102 |
| LIME WITH SILVER REFLECTIVE - 5X | 3015103 |
| LIME WITH SILVER REFLECTIVE - 6X | 3015104 |

| DESCRIPTION | PART # |
|--|---------|
| ORANGE W/LIME/SILVER/LIME TRIM - M-XL | 3015095 |
| ORANGE W/LIME/SILVER/LIME TRIM - 2X-5X | 3015096 |

SPECIALITY SAFETY VESTS



Constructed of heavy-duty 9 oz. vinyl coated fluorescent knit fabric. Reflective 1-3/8" vertical stripes and 4"x16" reflective patches on both front and back. Reflective colors of lime or white only. Available with single or double patches. 3/4"x2" front hook and loop closure with 3/4"x8" elastic straps. Contact customer service for more details at (800)428-8185. (*stocked items)

| DESCRIPTION | PART # | |
|-------------------------------|---------|-----------|
| BLUE POLICE WITH LIME* | 3006292 | [0104258] |
| ORANGE POLICE WITH LIME* | 3006293 | [0104260] |
| ORANGE SECURITY WITH LIME* | 3007569 | [2084635] |
| BROWN SHERIFF WITH LIME | 3006294 | [0104296] |
| ORANGE FIRE WITH LIME | 3008010 | [2193742] |
| LIME POLICE WITH WHITE | 3008000 | [2193730] |
| ORANGE SHERIFF WITH LIME | 3008035 | [2193835] |
| LIME FIRE WITH WHITE | 3008030 | [2193811] |
| ORANGE PARKING WITH LIME | 3008008 | [2193740] |
| ORANGE SAFETY WITH LIME | 3007999 | [2193728] |
| ORANGE SAFETY WITH LIME | 3008004 | [2193735] |
| BLUE BLANK WITH LIME | 3006723 | [2014038] |
| LIME SHERIFF WITH WHITE | 3008045 | [2193862] |
| BLUE EMS WITH LIME | 3008023 | [2193785] |
| ORANGE SCHOOL GUARD WITH LIME | 3008016 | [2193773] |

| DESCRIPTION | PART # | |
|--|---------|-----------|
| GREEN SHERIFF WITH LIME | 3006715 | [2014013] |
| LIME SECURITY WITH LIME | 3006826 | [2014223] |
| BLACK POLICE WITH LIME | 3006788 | [2014181] |
| ORANGE TRAFFIC CONTROL W/WHITE | 3008046 | [2193864] |
| LIME EMS WITH WHITE | 3007991 | [2193704] |
| LIME BLANK WITH WHITE | 3006872 | [2014279] |
| BLUE SHERIFF WITH WHITE | 3013129 | |
| BLUE SECURITY WITH LIME | 3008083 | [2194000] |
| BLUE SECURITY WITH LIME | 3008005 | [2193736] |
| ORANGE FIRE WARDEN W/LIME DOUBLE PATCH | 3013697 | |
| FOREST GREEN BLANK W/LIME DOUBLE PATCH | 3006871 | [2014278] |
| BLUE BLANK W/LIME DOUBLE PATCH | 3006873 | [2014280] |
| YELLOW BLANK W/LIME DOUBLE PATCH | 3006874 | [2014281] |
| ORANGE BLANK W/ LIME DOUBLE PATCH | 3006731 | [2014071] |
| LIME BLANK WITH LIME DOUBLE PATCH | 3013438 | |
| LIME BLANK WITH WHITE DOUBLE PATCH | 3006989 | [2014424] |



ECONO STYLE ESK SAFETY VESTS

One size fits most. Elastic sides for easy fit. Mesh fabric. Hook and loop closure.



#3017585
Orange mesh
No reflective



#3017586
Lime mesh
No reflective



#3017587
Orange mesh
1/2" silver beaded



#3017588
Lime mesh
1/2" silver beaded



#3017589
Orange mesh
3/4" lime prismatic



#3017590
Lime mesh
3/4" orange prismatic tape



#3017591
Lime mesh
3/4" white prismatic tape



#3017592
Lime mesh
1-1/2" two-tone reflective tape
Available in orange mesh
with lime silver #3017592



#3017594
Orange mesh
1-3/8" lime prismatic



#3017595
Lime mesh
1-3/8" orange
prismatic tape

DESCRIPTION

| | |
|------------------------------------|---------|
| ORANGE, NO REFLECTIVE | 3017585 |
| ORANGE, 1/2" SILVER BEADED | 3017587 |
| ORANGE, 3/4" LIME PRISMATIC | 3017589 |
| ORANGE, 1-1/2" TWO-TONE REFLECTIVE | 3017592 |
| ORANGE, 1-3/8" LIME PRISMATIC | 3017594 |
| LIME, NO REFLECTIVE | 3017586 |
| LIME, 1/2" SILVER BEADED | 3017588 |
| LIME, 3/4" ORANGE PRISMATIC | 3017590 |
| LIME, 3/4" WHITE PRISMATIC | 3017591 |
| LIME, 1-1/2" TWO-TONE REFLECTIVE | 3017593 |
| LIME, 1-3/8" ORANGE PRISMATIC TAPE | 3017595 |

PART #

safety apparel

GENERAL PURPOSE GPV SAFETY VESTS



3/4" x 2" front hook and loop front closure with 3/4" x 8" elastic side straps. Constructed of flat weave, 7 oz. poly vinyl coated for durability. Can be wiped clean. Cannot be screen printed.

DESCRIPTION

| | | |
|-------------------------------------|---------|-----------|
| ORANGE, NON-REFLECTIVE | 3006270 | [0104040] |
| ORANGE, LIME WITH SILVER BEADED - L | 3007308 | [2057992] |
| ORANGE, LIME PRISMATIC - L | 3006273 | [0104090] |

PART #



LIGHTED L.E.D. SAFETY VESTS



Hook and loop front closure. Flashing L.E.D. in two vertical stripes on front and one vertical stripe on back. Water resistant battery pouch and case holds two standard 'AA' batteries (not included). Battery life is approximately 400 hours.

| DESCRIPTION | PART # |
|----------------------------------|-------------------|
| L.E.D. LIGHTED, FLASHING, ORANGE | 3008836 [2212074] |
| L.E.D. LIGHTED, FLASHING, LIME | 3008840 [2212093] |

NON-ANSI HIGH PERFORMANCE T-SHIRTS



Ribbed collar with a stitched hem for added comfort and durability. Convenient chest pocket for additional storage. CoolDRY™ 100% polyester moisture management fabric wicks away excess moisture. Machine washable.

| DESCRIPTION | PART # |
|-----------------------------------|---------|
| ORANGE T-SHIRT, SHORT SLEEVE - L | 3014473 |
| ORANGE T-SHIRT, SHORT SLEEVE - XL | 3014474 |
| ORANGE T-SHIRT, SHORT SLEEVE - 2X | 3014475 |
| ORANGE T-SHIRT, SHORT SLEEVE - 3X | 3014836 |
| ORANGE T-SHIRT, SHORT SLEEVE - 4X | 3014837 |
| LIME T-SHIRT, SHORT SLEEVE - L | 3014476 |
| LIME T-SHIRT, SHORT SLEEVE - XL | 3014477 |
| LIME T-SHIRT, SHORT SLEEVE - 2X | 3014478 |
| LIME T-SHIRT, SHORT SLEEVE - 3X | 3014840 |
| LIME T-SHIRT, SHORT SLEEVE - 4X | 3014841 |

ANSI CLASS 2 T-SHIRTS

360° visibility with reflective tape. Machine washable.



Meets ANSI/ISEA 107 Class 2 standards. Choose from long or short sleeve styles. Available in both orange and lime. Long sleeves provide additional protection against harmful U.V. rays. Chest pocket with continuous silver reflective tape. Ribbed collar and cuffs with a stitched hem for added comfort and durability. CoolDRY™ 100% polyester moisture management fabric wicks away excess moisture. Machine washable.

| DESCRIPTION | PART # | DESCRIPTION | PART # |
|---------------------------|---------|--------------------------|---------|
| ANSI CLASS 2 SHORT SLEEVE | | ANSI CLASS 2 LONG SLEEVE | |
| ORANGE WITH SILVER - L | 3012943 | ORANGE WITH SILVER - L | 3012951 |
| ORANGE WITH SILVER - XL | 3012944 | ORANGE WITH SILVER - XL | 3012952 |
| ORANGE WITH SILVER - 2X | 3012945 | ORANGE WITH SILVER - 2X | 3012953 |
| ORANGE WITH SILVER - 3X | 3012946 | ORANGE WITH SILVER - 3X | 3012954 |
| LIME WITH SILVER - L | 3012947 | LIME WITH SILVER - L | 3012955 |
| LIME WITH SILVER - XL | 3012948 | LIME WITH SILVER - XL | 3012956 |
| LIME WITH SILVER - 2X | 3012949 | LIME WITH SILVER - 2X | 3012957 |
| LIME WITH SILVER - 3X | 3012950 | LIME WITH SILVER - 3X | 3012958 |

ANSI CLASS 3 T-SHIRTS

360° visibility with reflective tape. Machine washable.

Meets ANSI/ISEA 107 Class 3 standards. Choose from long or short sleeve styles, available in both orange and lime. Long sleeves provide additional protection against harmful U.V. rays. Chest pocket with continuous silver reflective tape. Ribbed collar and cuffs with a stitched hem for added comfort and durability. CoolDRY™ 100% polyester moisture management fabric wicks away excess moisture. Machine washable.



| DESCRIPTION | PART # | DESCRIPTION | PART # |
|---------------------------|---------|--------------------------|---------|
| ANSI CLASS 3 SHORT SLEEVE | | ANSI CLASS 3 LONG SLEEVE | |
| ORANGE WITH SILVER - L | 3014808 | ORANGE WITH SILVER - L | 3014822 |
| ORANGE WITH SILVER - XL | 3014809 | ORANGE WITH SILVER - XL | 3014823 |
| ORANGE WITH SILVER - 2X | 3014810 | ORANGE WITH SILVER - 2X | 3014824 |
| ORANGE WITH SILVER - 3X | 3014811 | ORANGE WITH SILVER - 3X | 3014825 |
| ORANGE WITH SILVER - 4X | 3014812 | ORANGE WITH SILVER - 4X | 3014826 |
| LIME WITH SILVER - L | 3014815 | LIME WITH SILVER - L | 3014829 |
| LIME WITH SILVER - XL | 3014816 | LIME WITH SILVER - XL | 3014830 |
| LIME WITH SILVER - 2X | 3014817 | LIME WITH SILVER - 2X | 3014831 |
| LIME WITH SILVER - 3X | 3014818 | LIME WITH SILVER - 3X | 3014832 |
| LIME WITH SILVER - 4X | 3014819 | LIME WITH SILVER - 4X | 3014833 |

ANSI RAINWEAR

360° visibility with reflective tape. Machine washable.

HydroGARD™ coated polyester outer shell provides a waterproof and breathable system. Two outside front pockets with flip over snap closure and one inside pocket. Under arm vents for added circulation and cooling. Convenient stow away hood inside collar. Snap closure on sleeve cuff closes the space around the hands.

ANSI CLASS 3



Shown #3012931



Shown #3012927

ANSI CLASS 3 RAIN JACKET

| DESCRIPTION | PART # |
|---------------------------------|---------|
| ANSI CLASS 3 RAIN JACKET | |
| ORANGE CLASS 3 RAIN JACKET - L | 3012926 |
| ORANGE CLASS 3 RAIN JACKET - XL | 3012927 |
| ORANGE CLASS 3 RAIN JACKET - 2X | 3012928 |
| ORANGE CLASS 3 RAIN JACKET - 3X | 3012929 |
| LIME CLASS 3 RAIN JACKET - L | 3012930 |
| LIME CLASS 3 RAIN JACKET - XL | 3012931 |
| LIME CLASS 3 RAIN JACKET - 2X | 3012932 |
| LIME CLASS 3 RAIN JACKET - 3X | 3012933 |

ANSI CLASS E RAIN PANTS

| DESCRIPTION | PART # |
|--------------------------------|---------|
| ANSI CLASS E RAIN PANTS | |
| ORANGE CLASS E RAIN PANTS - L | 3012935 |
| ORANGE CLASS E RAIN PANTS - XL | 3012936 |
| ORANGE CLASS E RAIN PANTS - 2X | 3012937 |
| ORANGE CLASS E RAIN PANTS - 3X | 3012938 |
| LIME CLASS E RAIN PANTS - L | 3012939 |
| LIME CLASS E RAIN PANTS - XL | 3012940 |
| LIME CLASS E RAIN PANTS - 2X | 3012941 |
| LIME CLASS E RAIN PANTS - 3X | 3012942 |



Shown #3012940



Shown #3012936

ANSI CLASS E

ANSI STORM APPAREL

360° visibility with reflective tape. Machine washable.

ANSI CLASS 3 STORM JACKET

Meets ANSI/ISEA 107-2004 Class 3 standards. Velcro adjustable cuffs. Convenient stow away hood folds inside collar. Non-ANSI fleece lined inner vest can be zipped out and worn alone.



Shown #3009694

ANSI CLASS 3

| DESCRIPTION | PART # |
|--|-------------------|
| ORANGE JACKET W/SILVER REFLECTIVE - L | 3009694 [9150000] |
| ORANGE JACKET W/SILVER REFLECTIVE - XL | 3009298 [9150001] |
| ORANGE JACKET W/SILVER REFLECTIVE - 2X | 3009695 [9150002] |
| ORANGE JACKET W/SILVER REFLECTIVE - 3X | 3009696 [9150003] |
| LIME JACKET W/SILVER REFLECTIVE - L | 3009698 [9150100] |
| LIME JACKET W/SILVER REFLECTIVE - XL | 3009699 [9150101] |
| LIME JACKET W/SILVER REFLECTIVE - 2X | 3009700 [9150102] |
| LIME JACKET W/SILVER REFLECTIVE - 3X | 3009701 [9150103] |

ANSI CLASS E STORM PANTS

Meets ANSI/ISEA 107 Class E standards. Unlined storm pants. Side zipper for coverage over boots. Side slit pockets, single rear pocket with flap and zipper. Belted waist and zipper fly.



Shown #3009702

ANSI CLASS E

| DESCRIPTION | PART # |
|---------------------------------------|-------------------|
| ORANGE PANTS W/SILVER REFLECTIVE - L | 3009702 [9151000] |
| ORANGE PANTS W/SILVER REFLECTIVE - XL | 3009299 [9151001] |
| ORANGE PANTS W/SILVER REFLECTIVE - 2X | 3009704 [9151002] |
| ORANGE PANTS W/SILVER REFLECTIVE - 3X | 3009705 [9151003] |
| LIME PANTS W/SILVER REFLECTIVE - L | 3009706 [9151100] |
| LIME PANTS W/SILVER REFLECTIVE - XL | 3009707 [9151101] |
| LIME PANTS W/SILVER REFLECTIVE - 2X | 3009708 [9151102] |
| LIME PANTS W/SILVER REFLECTIVE - 3X | 3009710 [9151103] |

safety apparel



MEETS ANSI/ISEA 107-2004 STANDARDS

ANSI CLASS 3 CONVERTIBLE PARKA

360° visibility with reflective tape. Machine washable.



ANSI CLASS 3

Shown #3009724
CL3 with sleeves



ANSI CLASS 2

Shown #3009724
CL2 without sleeves

Meets ANSI/ISEA 107-2004 Class 3 with sleeves and converts to meet ANSI/ISEA 107-2004 Class 2 without sleeves. Convenient stow away hood inside collar. Zipper travels through extended collar for full insulation. Zips into the All Weather System Jacket (shown below) for additional warmth and versatile style.

| DESCRIPTION | PART # |
|------------------------------------|-------------------|
| ORANGE WITH SILVER REFLECTIVE - L | 3009724 [9153000] |
| ORANGE WITH SILVER REFLECTIVE - XL | 3009726 [9153001] |
| ORANGE WITH SILVER REFLECTIVE - 2X | 3009727 [9153002] |
| ORANGE WITH SILVER REFLECTIVE - 3X | 3009728 [9153003] |
| LIME WITH SILVER REFLECTIVE - L | 3009729 [9153100] |
| LIME WITH SILVER REFLECTIVE - XL | 3009301 [9153101] |
| LIME WITH SILVER REFLECTIVE - 2X | 3009731 [9153102] |
| LIME WITH SILVER REFLECTIVE - 3X | 3009733 [9153103] |

ANSI ALL WEATHER APPAREL

360° visibility with reflective tape. Machine washable.



ANSI CLASS 3

Shown #3009712

ANSI CLASS 3 ALL WEATHER SYSTEM JACKET

Meets ANSI/ISEA 107-2004 Class 3 standards. ANSI Class 3 Convertible parka (shown above) may be zipped inside for additional protection and warmth. Convenient snap-on hood. Insulated patch pockets with flaps. Elastic cuffs with adjustable closure.



ANSI CLASS E

Shown #3009739

ANSI CLASS E ALL WEATHER PANTS

Meets ANSI/ISEA 107 Class E standards. Fleece lined storm pants. Bottom side zipper for coverage over boots. Side slit pockets and single rear pocket with flap and zipper. Belted waist and zipper fly.

| DESCRIPTION | PART # |
|------------------------------------|-------------------|
| ORANGE WITH SILVER REFLECTIVE - L | 3009712 [9150000] |
| ORANGE WITH SILVER REFLECTIVE - XL | 3009713 [9150001] |
| ORANGE WITH SILVER REFLECTIVE - 2X | 3009716 [9150002] |
| ORANGE WITH SILVER REFLECTIVE - 3X | 3009719 [9150003] |
| LIME WITH SILVER REFLECTIVE - L | 3009718 [9150100] |
| LIME WITH SILVER REFLECTIVE - XL | 3009300 [9150101] |
| LIME WITH SILVER REFLECTIVE - 2X | 3009720 [9150102] |
| LIME WITH SILVER REFLECTIVE - 3X | 3009722 [9150103] |

| DESCRIPTION | PART # |
|------------------------------------|-------------------|
| ORANGE WITH SILVER REFLECTIVE - L | 3009734 [9152000] |
| ORANGE WITH SILVER REFLECTIVE - XL | 3009736 [9152001] |
| ORANGE WITH SILVER REFLECTIVE - 2X | 3009737 [9152002] |
| ORANGE WITH SILVER REFLECTIVE - 3X | 3009738 [9152003] |
| LIME WITH SILVER REFLECTIVE - L | 3009739 [9152100] |
| LIME WITH SILVER REFLECTIVE - XL | 3009302 [9152101] |
| LIME WITH SILVER REFLECTIVE - 2X | 3009740 [9152102] |
| LIME WITH SILVER REFLECTIVE - 3X | 3009741 [9152103] |



Shown in image: #3009729 - Lime Parka, #3009298 - Orange Storm Jacket

Jackson Safety uses only the most durable finest materials to produce our traffic safety products. We promise that all of our collars fit specific to the style of the cone in order to meet all of the necessary standards required to provide you with the ultimate protection in any work environment.

STANDARDS & REGULATIONS

MUTCD (Manual on Uniform Traffic Control Devices)

The Manual on Uniform Traffic Control Devices (MUTCD) is a document issued by the Federal Highway Administration (FHWA) of the United States Department of Transportation (USDOT) to specify the standards by which traffic signs, road markings and signals are designed, installed and used. In the United States, all traffic control devices must generally conform to these standards. The manual is used by state and local agencies as well as private construction firms to ensure that the traffic control devices they use conform to the national standard. While some state agencies have developed their own set of standards, their standards must be in substantial conformance with the MUTCD.

NCHRP 350 (National Cooperative Highway Research Program)

The National Cooperative Highway Research Program represents uniform guidelines for conducting full-scale crash tests for permanent and temporary highway safety features along with recommended evaluation criteria to assess the test results. The crash performance is judged on structural adequacy, occupant risk and vehicle trajectory. Category I devices may be self-certified and include traffic cones, channelizer drums (without lights) and delineators. Category II devices must be crash-tested include channelizer drums (with lights), vertical panels, barricades (Types I, II and III) and sign stands.

ITE (Institute of Transportation Engineers)

The Institute of Transportation Engineers is an international educational and scientific association of transportation professionals who attempt to meet mobility and safety needs and was founded in 1930. ITE is a standards development organization designated by the U.S. Department of Transportation. Traffic barricade lights must also adhere to ITE testing standards.



As the market leader in traffic cones, we manufacture all of our traffic cones in the United States to meet NCHRP 350 Category 1 and MUTCD standards.



trafficsafety

CUSTOM IMPRINTING

Imprinting and silk screening are available for all traffic cones. 50 cone minimum per order. Lead time required. Refer to Jackson Safety price list for set-up fees and charges. Only available in black ink.

STENCILING

Stenciling available for both the outside of the cone and the inside liner. One-time stencil set-up fee applies. Per cone additional charge applies for inner and outer stencil. Standard legends for imprinted cones require no set-up charge and include the following: WET FLOOR, CAUTION, DANGER, KEEP OUT, NO PARKING, NO SMOKING.

SILK SCREEN

Silk screen available on the outside of cone only. Film charge applies for silk screen. Camera-ready artwork must be provided for all silk screens. Camera-ready artwork is defined as "digital form, 1-bit format, true black on white (no gray scale) of imprint. Image must be the same size for the graphic to be printed.

CUSTOM IMPRINTS: AVAILABLE SPACE PER SCREEN

| CONES WITHOUT COLLARS | | CONES WITH COLLARS | |
|-----------------------|-------------|--------------------|-------------|
| 18" | 5"W x 10"H | 18" | 5"W x 6"H |
| 28" | 10"W x 18"H | 28" | 10"W x 9"H |
| 36" | 11"W x 22"H | 36" | 11"W x 17"H |



DW SERIES



Shown left #3004231 & #3004256

Wide body design with rugged black base.
Flow molded, dayglow orange PVC with white inner liner.

| DESCRIPTION | PART # | |
|--|---------|-----------|
| 6" DW CONE - 1.5 LBS | 3004101 | [0100680] |
| 12" DW CONE - 1.5 LBS | 3004020 | [0100032] |
| 18" DW CONE - 3 LBS | 3004023 | [0100109] |
| 18" DW CONE - 6" COLLAR, 3 LBS, 3M | 3004319 | [2215283] |
| 18" DW CONE - 6" COLLAR, 3 LBS, REFLEXITE | 3004282 | [2202539] |
| 28" DW CONE - 7 LBS | 3004057 | [0100355] |
| 28" DW CONE - 6" & 4" COLLARS, 7 LBS, 3M | 3004236 | [2193643] |
| 28" DW CONE - 6" & 4" COLLARS, 7 LBS, REFLEXITE | 3004206 | [2084350] |
| 28" DW CONE - 10 LBS | 3004176 | [2058647] |
| 28" DW CONE - 6" & 4" COLLARS, 10 LBS, 3M | 3004256 | [2202353] |
| 28" DW CONE - 6" & 4" COLLARS, 10 LBS, REFLEXITE | 3008293 | |
| 28" DW CONE - 6" & 4" COLLARS, 10 LBS, AVERY | 3004254 | [2202341] |
| 28" DW CONE - FLAGTOP, 7 LBS | 3004059 | [0100408] |
| 36" DW CONE - 10 LBS | 3004159 | [2058116] |
| 36" DW CONE - 6" & 4" COLLARS, 10 LBS, 3M | 3004231 | [2193631] |
| 36" DW CONE - 6" & 4" COLLARS, 10 LBS, REFLEXITE | 3007315 | [2058117] |
| 36" DW CONE - 12 LBS | 3004226 | [2089926] |
| 36" DW CONE - 6" & 4" COLLARS, 12 LBS, REFLEXITE | 3004243 | [2196839] |

W SERIES



Shown left #3004280 & #3004019

Wide body design with rugged orange base.
Flow molded, dayglow orange PVC with white inner liner.

| DESCRIPTION | PART # | |
|--|---------|-----------|
| 4" W CONE - .38 LBS | 3004094 | [0100666] |
| 12" W CONE - 2 LBS | 3004019 | [0100006] |
| 18" W CONE - 2.5 LBS | 3004042 | [0100238] |
| 18" W CONE - 4" UPPER COLLAR, 2.5 LBS, REFLEXITE | 3004043 | [0100239] |
| 18" W CONE - 6" UPPER COLLAR, 2.5 LBS, 3M | 3004370 | [2219447] |
| 18" W CONE - 6" UPPER COLLAR, 2.5 LBS, REFLEXITE | 3004607 | [2215765] |
| 28" W CONE - 6.5 LBS | 3004158 | [2058087] |
| 28" W CONE - 6" & 4" COLLARS, 6.5 LBS, 3M | 3004245 | [2196970] |
| 28" W CONE - 6" & 4" COLLARS, 6.5 LBS, REFLEXITE | 3004242 | [2196230] |
| 28" W CONE - 7 LBS | 3004181 | [2068000] |
| 28" W CONE - 6" & 4" COLLARS, 7 LBS, 3M | 3004183 | [2068002] |
| 28" W CONE - 6" & 4" COLLARS, 7 LBS, REFLEXITE | 3007415 | [2068010] |
| 28" W CONE - 10 LBS | 3004175 | [2058635] |
| 28" W CONE - 6" & 4" COLLARS, 10 LBS, 3M | 3004259 | [2202377] |
| 28" W CONE - 6" & 4" COLLARS, 10 LBS, REFLEXITE | 3004258 | [2202369] |
| 36" W CONE - 10 LBS | 3004160 | [2058130] |
| 36" W CONE - 6" & 4" COLLARS, 10 LBS, 3M | 3004272 | [2202432] |
| 36" W CONE - 6" & 4" COLLARS, 10 LBS, REFLEXITE | 3008307 | [2202426] |
| 36" W CONE - 12 LBS | 3004278 | [2202468] |
| 36" W CONE - 6" & 4" COLLARS, 12 LBS, 3M | 3004280 | [2202482] |
| 36" W CONE - 6" & 4" COLLARS, 12 LBS, REFLEXITE | 3004279 | [2202470] |

W SERIES: RECESSED CONES



Shown right
#3004604

One piece wide body design and construction. Easier stacking with no pinch points for collars. Increased durability for reflective sheeting; recessed collars resist direct wear. Protected reflective translates into longer service life lowering overall usage costs.

| DESCRIPTION | PART # | |
|---|---------|-----------|
| 28" W CONE RECESSED - 6" & 4" COLLARS, 7 LBS, 3M | 3004604 | [2069001] |
| 28" W CONE RECESSED - W/O TAPE, 7 LBS | 3004204 | [2069000] |
| 36" W CONE RECESSED - FLORIDA D.O.T. W/O | 3015126 | |
| 36" W CONE RECESSED - 6" & 4" COLLARS, 12 LBS | 3015127 | |
| 36" W CONE RECESSED - 6" & 4" COLLARS, 12 LBS, 3M | 3015128 | |

FLUORESCENT LIME



Shown left #3004297

W Series, wide body design. Flow molded, dayglow fluorescent lime with white inner liner. Differentiates work zone for added measure of safety. Fluorescent color increases pedestrian and driver awareness.

DESCRIPTION

- 18" W CONE FLUORESCENT LIME - 2.5 LBS
- 28" W CONE FLUORESCENT LIME - 6.5 LBS
- 28" W CONE FLUORESCENT LIME - 6" & 4" COLLARS, 6.5 LBS, AVERY
- 28" W CONE FLUORESCENT LIME - 6" & 4" COLLARS, 6.5 LBS, 3M
- 36" W CONE FLUORESCENT LIME - 10 LBS
- 36" W CONE FLUORESCENT LIME - 6" & 4" COLLARS, 10 LBS , AVERY

PART #

- 3004283 [2212126]
- 3004286 [2212138]
- 3004288 [2212152]
- 3004297 [2214540]
- 3004287 [2212140]
- 3004290 [2212164]

F SERIES



Shown left #3004179

Heavy, slim line body design to enhance wind resistance. Flow molded, dayglow red/orange with white inner liner.

DESCRIPTION

- 28" F CONE - 10 LBS
- 28" F CONE - 6" & 4" COLLARS, 10 LBS, REFLEXITE
- 28" F CONE - 6" & 4" COLLARS, 10 LBS, 3M
- 28" F CONE - 6" & 4" COLLARS, 10 LBS, AVERY

PART #

- 3004179 [2058659]
- 3004262 [2202391]
- 3004252 [2197390]
- 3004263 [2202395]

FL SERIES



Shown left #3004085 & #3004071

Narrow wind resistant profile with orange base. Flow molded, dayglow red/orange PVC with white inner liner.

DESCRIPTION

- 18" FL CONE - 2.4 LBS
- 18" FL CONE - 4" COLLAR, 2.4 LBS, 3M
- 18" FL CONE - 4" COLLAR, 2.4 LBS, REFLEXITE
- 18" FL CONE - 6" COLLAR, 2.4 LBS, 3M
- 18" FL CONE - 6" COLLAR, 2.4 LBS, REFLEXITE
- 28" FL CONE - 5.5 LBS
- 28" FL CONE - 6" & 4" COLLARS, 5.5 LBS, 3M
- 28" FL CONE - 6" & 4" COLLARS, 5.5 LBS, REFLEXITE
- 36" FL CONE - 8 LBS
- 36" FL CONE - 6" & 4" COLLARS, 8 LBS, 3M
- 36" FL CONE - 6" & 4" COLLARS, 8 LBS, REFLEXITE

PART #

- 3004034 [0100185]
- 3004322 [2215611]
- 3004315 [2215207]
- 3009162 [2217982]
- 3004317 [2215221]
- 3004071 [0100484]
- 3004251 [2197388]
- 3010108
- 3004085 [0100604]
- 3004277 [2202456]
- 3004275 [2202444]

PACK AND POP COLLAPSIBLE CONE



Internal cone light features 2 settings: steady burn and flashing. Operates on 2 'AAA' batteries (included) and endures 100,000 flashes or 36 hours of steady burn. Constructed with orange waterproof nylon that assures visibility in all weather environments.

DESCRIPTION

- 18" PACK & POP COLLAPSIBLE CONE WITHOUT FEET
- 28" PACK & POP COLLAPSIBLE CONE WITH FEET

PART #

- 3012918
- 3018159 3012917

4 Pack and Pop cones fit in 1 carrying bag when fully collapsed



| NEW PART # | OLD PART # | MATERIAL DESCRIPTION | BASE WIDTH (INCHES) | BASE LENGTH (INCHES) | UNIT WEIGHT (LBS) | PALLET QTY (UNITS) |
|---|------------|---|---------------------|----------------------|-------------------|--------------------|
| DW SERIES TRAFFIC CONES | | | | | | |
| 3004101 | 0100680 | DW CONE - 6" | 8 | 8 | 1.5 | 500 |
| 3004020 | 0100032 | DW CONE - 12" | 8 | 8 | 1.5 | 500 |
| 3004023 | 0100109 | DW CONE - 18" | 10.75 | 10.75 | 3 | 500 |
| 3004319 | 2215283 | DW CONE - 18" W/6" UPPER 3M | 11 | 11 | 3 | 500 |
| 3004282 | 2202539 | DW CONE - 18" W/6" UPPER REFLX | 11 | 11 | 3 | 500 |
| 3004057 | 0100355 | DW CONE - 28" | 14 | 14 | 7 | 250 |
| 3004236 | 2193643 | DW CONE - 28" W/6" UPPER 4" LOWER 3M | 14 | 14 | 7 | 250 |
| 3004206 | 2084350 | DW CONE - 28" W/6" UPPER 4" LOWER REFLX | 14 | 14 | 7 | 250 |
| 3004176 | 2058647 | DW CONE - 28" | 14 | 14 | 10 | 200 |
| 3004256 | 2202353 | DW CONE - 28" W/6" UPPER 4" LOWER 3M | 14 | 14 | 10 | 200 |
| 3008293 | N/A | DW CONE - 28" W/6" UPPER 4" LOWER REFLX | 14 | 14 | 10 | 200 |
| 3004059 | 0100408 | DW CONE - 28" FLAGTOP | 14 | 14 | 7 | 250 |
| 3004159 | 2058116 | DW CONE - 36" | 14 | 14 | 10 | 150 |
| 3004231 | 2193631 | DW CONE - 36" W/6" UPPER 4" LOWER 3M | 14 | 14 | 10 | 150 |
| 3007315 | 2058117 | DW CONE - 36" W/6" UPPER 4" LOWER REFLX | 14 | 14 | 10 | 150 |
| 3004226 | 2089926 | DW CONE - 36" | 14 | 14 | 12 | 150 |
| 3004243 | 2196839 | DW CONE - 36" W/6" UPPER 4" LOWER REFLX | 14 | 14 | 12 | 150 |
| W SERIES TRAFFIC CONES | | | | | | |
| 3004019 | 0100006 | W CONE - 12" | 9 | 9 | 2 | 500 |
| 3004042 | 0100238 | W CONE - 18" | 10.75 | 10.75 | 2.5 | 500 |
| 3004043 | 0100239 | W CONE - 18" W/4" UPPER REFLX | 10.75 | 10.75 | 2.5 | 500 |
| 3004370 | 2219447 | W CONE - 18" W/6" UPPER 3M | 10.75 | 10.75 | 2.5 | 500 |
| 3004607 | 2215765 | W CONE - 18" W/6" UPPER REFLX | 10.75 | 10.75 | 2.5 | 500 |
| 3004158 | 2058087 | W CONE - 28" | 14.5 | 14.5 | 6.5 | 250 |
| 3004245 | 2196970 | W CONE - 28" W/6" UPPER 4" LOWER 3M | 14.5 | 14.5 | 6.5 | 250 |
| 3004242 | 2196230 | W CONE - 28" W/6" UPPER 4" LOWER REFLX | 14.5 | 14.5 | 6.5 | 250 |
| 3004181 | 2068000 | W CONE - 28" | 14.5 | 14.5 | 7 | 250 |
| 3004183 | 2068002 | W CONE - 28" W/ 6" UPPER 4" LOWER 3M | 14.5 | 14.5 | 7 | 250 |
| 3007415 | 2068010 | W CONE - 28" W/6" UPPER 4" LOWER REFLX | 14.5 | 14.5 | 7 | 250 |
| 3004175 | 2058635 | W CONE - 28" | 14.5 | 14.5 | 10 | 200 |
| 3004259 | 2202377 | W CONE - 28" W/6" UPPER 4" LOWER 3M | 14.5 | 14.5 | 10 | 200 |
| 3004258 | 2202369 | W CONE - 28" W/6" UPPER 4" LOWER REFLX | 14.5 | 14.5 | 10 | 200 |
| 3004160 | 2058130 | W CONE - 36" | 14.5 | 14.5 | 10 | 150 |
| 3004272 | 2202432 | W CONE - 36" W/ 6" UPPER 4" LOWER 3M | 14.5 | 14.5 | 10 | 150 |
| 3008307 | 2202426 | W CONE - 36" W/ 6" UPPER 4" LOWER REFLX | 14.5 | 14.5 | 10 | 150 |
| 3004278 | 2202468 | W CONE - 36" | 14.5 | 14.5 | 12 | 150 |
| 3004280 | 2202482 | W CONE - 36" W/ 6" UPPER 4" LOWER 3M | 14.5 | 14.5 | 12 | 150 |
| 3004279 | 2202470 | W CONE - 36" W/ 6" UPPER 4" LOWER REFLX | 14.5 | 14.5 | 12 | 150 |
| W SERIES: RECESSED TRAFFIC CONES | | | | | | |
| 3004604 | 2069001 | W CONE - 28" RECESSED, 6" UPPER 4" LOWER, 3M | 14.5 | 14.5 | 6.5 | 250 |
| 3004204 | 2069000 | W CONE - 28" RECESSED | 14.5 | 14.5 | 6.5 | 250 |
| 3015126 | N/A | W CONE - 36" RECESSED, FLORIDA D.O.T. W/O | 14.5 | 14.5 | 10 | 150 |
| 3015127 | N/A | W CONE - 36" RECESSED, 6" UPPER 4" LOWER REFLEX | 14.5 | 14.5 | 10 | 150 |
| 3015128 | N/A | W CONE - 36" RECESSED, 6" UPPER 4" LOWER, FL/O/H | 14.5 | 14.5 | 10 | 150 |
| W SERIES: FLUORESCENT LIME TRAFFIC CONES | | | | | | |
| 3004283 | 2212126 | W CONE - 18" FLUORESCENT LIME | 10.75 | 10.75 | 2.5 | 500 |
| 3004286 | 2212138 | W CONE - 28" FLUORESCENT LIME | 14.5 | 14.5 | 6.5 | 250 |
| 3004288 | 2212152 | W CONE - 28" FLUORES. LIME W/6" UPPER 4" LOWER | 14.5 | 14.5 | 6.5 | 250 |
| 3004297 | 2214540 | W CONE - 28" FLUORES. LIME W/6" UPPER 4" LOWER 3M | 14.5 | 14.5 | 6.5 | 250 |
| 3004287 | 2212140 | W CONE - 36" FLUORESCENT LIME | 14.5 | 14.5 | 10 | 150 |
| 3004290 | 2212164 | W CONE - 36" FLUORES. LIME W/6" UPPER 4" LOWER | 14.5 | 14.5 | 10 | 150 |
| FL SERIES TRAFFIC CONES | | | | | | |
| 3004034 | 100185 | FL CONE - 18" | 10 | 10 | 2.4 | 500 |
| 3004315 | 2215207 | FL CONE - 18" W/4" COLLAR REFLX | 10 | 10 | 2.4 | 500 |
| 3009162 | 2217982 | FL CONE - 18" W/6" COLLAR 3M | 10 | 10 | 2.4 | 500 |
| 3004317 | 2215221 | FL CONE - 18" W/6" COLLAR REFLX | 10 | 10 | 2.4 | 500 |
| 3004071 | 0100484 | FL CONE - 28" | 13 | 13 | 5.5 | 250 |
| 3004251 | 2197388 | FL CONE - 28" W/6" UPPER 4" LOWER 3M | 13 | 13 | 5.5 | 250 |
| 3010108 | N/A | FL CONE - 28" W/6" UPPER 4" LOWER REFLX | 13 | 13 | 5.5 | 250 |
| 3004085 | 0100604 | FL CONE - 36" | 13 | 13 | 8 | 150 |
| 3004277 | 2202456 | FL CONE - 36" W/6" UPPER 4" LOWER 3M | 13 | 13 | 8 | 150 |
| 3004275 | 2202444 | FL CONE - 36" W/6" UPPER 4" LOWER REFLX | 13 | 13 | 8 | 150 |
| F SERIES TRAFFIC CONES | | | | | | |
| 3004179 | 2058659 | F CONE - 28" | 14.5 | 14.5 | 10 | 200 |
| 3004252 | 2197390 | F CONE - 28" W/6" UPPER 4" LOWER 3M | 14.5 | 14.5 | 10 | 200 |
| 3004262 | 2202391 | F CONE - 28" W/6" UPPER 4" LOWER REFLX | 14.5 | 14.5 | 10 | 200 |
| 3004263 | 2202395 | F CONE - 28" W/6" UPPER 4" LOWER AVERY | 14.5 | 14.5 | 10 | 200 |

SPORT CONES



Ideal for sporting events, parking lots, festivals and temporary (off highway) traffic delineation. Made from lightweight and durable injection-molded polyethylene. Sold in standard packs of 25 cones.

| DESCRIPTION | PART # |
|-----------------------|-------------------|
| 18" RED SPORT CONE | 3001764 [2027193] |
| 18" BLUE SPORT CONE | 3001766 [2027210] |
| 18" YELLOW SPORT CONE | 3001765 [2027208] |
| 18" WHITE SPORT CONE | 3001767 [2027222] |
| 18" ORANGE SPORT CONE | 3001761 [2008733] |
| 18" GREEN SPORT CONE | 3001768 [2027753] |

BARRICONE SYSTEM

Shown below 4 of #3007965



Cones sold separately

Fits on any style cone. Panels are manufactured of bright yellow PVC plastic with steel rings inserted into each end. Offered in reflective or non-reflective material. Reflective 4 ft. model utilizes two 3"x12" engineer grade barricade strips. Reflective 6 ft. model includes two 3" x 24" strips. On both styles, and the reflective strip offsets the word "CAUTION". Offered in 4' and 6' lengths and a width of 4".

| DESCRIPTION | PART # |
|--|-------------------|
| BARRICONE 4' - NO REFLECTIVE | 3007963 [2191932] |
| BARRICONE 4' - CAUTION WITH REFLECTIVE | 3007965 [2191956] |
| BARRICONE 6' - NO REFLECTIVE | 3007964 [2191944] |
| BARRICONE 6' - CAUTION WITH REFLECTIVE | 3007966 [2191968] |

MICROLITE FLASHING CONE LIGHT



Sits on any style 18", 28" or 36" traffic cone. Available in yellow case with 360° amber or red lens, with and without photo cell. Mounting bracket included. Powered by a single 6V lantern battery (not included). Flash rate of 120 - 150 flashes per minute. Dimensions: 8" high x 3-1/4" diameter.

| DESCRIPTION | PART # |
|---------------------------------------|-------------------|
| MICROLITE WITH PHOTOCCELL, AMBER LENS | 3007647 [2095594] |
| MICROLITE - AMBER LENS | 3007533 [2083173] |
| MICROLITE WITH PHOTOCCELL, RED LENS | 3008108 [2195421] |
| MICROLITE - RED LENS | 3008107 [2195419] |
| REPLACEMENT BULB #1850 | 3007279 [2033192] |
| LANTERN BATTERY - 12/BOX | 3001752 [0118144] |

CONE HOLDER

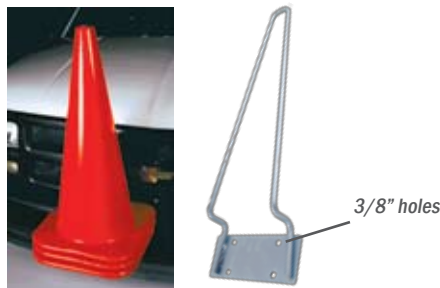

Ideal for vehicular use. Holds no more than (10) 18" cones or (5) 28" cones only. Mounting plate is 6.75" wide. Height of unit = 22" from bottom of mounting plate to top of holder. Hardware not included.

| DESCRIPTION | PART # |
|-------------|-------------------|
| CONE HOLDER | 3001749 [0116976] |

CONE STABILIZER



Minimizes potential of cones blowing over. Octagon-shaped stabilizer provides easy placement over cone without overlap. Fits all sizes and types of traffic cones. Weight: 5 lbs.

| DESCRIPTION | PART # |
|---------------------------|-------------------|
| 9-1/2" HOLE, F & FL CONES | 3004153 [0110130] |
| 11" HOLE, W & DW CONES | 3004154 [0110142] |

GRIP AND GO™ CHANNELIZER CONE



Channelizer cone utilizes less space than traditional barrels or drums. 42" tiered cone design with the easy Grip and Go handle. 47" to the handle top. Available with various reflective sheeting and recessed areas for protection when stacking. Handle accommodates most barricade lights and barrier tape products. Low density polyethylene with UV inhibitors minimizes fading. Exterior handle dimensions: 3-1/2"W x 5"L. Rubber bases have 8" interior opening.

| DESCRIPTION | PART # |
|--|---------|
| 42" CHANNELIZER WITH NO SHEETING | 3014081 |
| 42" CHANNELIZER (1) 4" & (1) 6" HI SHEETING | 3014082 |
| 42" CHANNELIZER (4) 4" HI SHEETING | 3014083 |
| 42" CHANNELIZER (4) 6" HI SHEETING | 3014084 |
| 42" CHANNELIZER (2) 6" DG & (2) 6" HI SHEETING | 3014085 |
| CHANNELIZER 10LB 16" OCTAGONAL BASE | 3009066 |
| CHANNELIZER 15LB 16" OCTAGONAL BASE | 3007532 |
| CHANNELIZER 20LB 26" X 12" RECTANGULAR BASE | 3014088 |
| CHANNELIZER 30LB 26" X 12" RECTANGULAR BASE | 3014089 |

IMPACT RECOVERY DELINEATORS



Flexible, high-impact delineation devices are designed with energy absorbing mechanics producing a longer lasting traffic control device. Constructed with a unique reactive spring to give with impact and rebound towards traffic. Withstands tested speeds up to 30 mph. Comes with a 'fixed' 8"x8" base designed for concrete median barriers or road surface application using bolts or epoxy (not included).

| DESCRIPTION | PART # |
|---|-------------------|
| 36" ORANGE DELINEATOR POST WITH BASE - WHITE SHEETING | 3007581 [2085961] |
| 42" ORANGE DELINEATOR POST WITH BASE - WHITE SHEETING | 3007579 [2085935] |
| 48" ORANGE DELINEATOR POST WITH BASE - WHITE SHEETING | 3007577 [2085909] |

DELUXE DELINEATOR POST



Standard 4" x 42" high post, overall height 47". Optional 3" round yellow reflective dot on both sides of post for additional safety. 16"W x 1-1/2"H octagonal base with interlocking high-density polyethylene post.

| DESCRIPTION | PART # |
|--|-------------------|
| 42" POST, WHITE HI INTENSITY COLLARS | 3007642 [2094294] |
| 42" POST, WHITE HI INTENSITY COLLARS, YELLOW REFL. DOT | 3008102 [2195366] |
| RUBBER DELINEATOR BASE - 10 LB | 3001742 [0102391] |
| RUBBER DELINEATOR BASE - 15 LB | 3006195 [0102406] |
| YELLOW REFLECTIVE DOT, NO POST INCLUDED 2-7/8" | 3008121 [2195902] |

MAXI-POST COMPONENTS

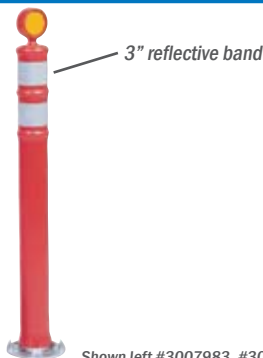

Standard 4" x 38" high post, overall height 43". Requires 8" diameter cast aluminum base with clamp. Order optional 3" round yellow reflective dot on both sides of post for additional safety or add later. Anchor bolts not included.

| DESCRIPTION | PART # |
|---|-------------------|
| POST ONLY, 42" X 3" | 3007643 [2094307] |
| POST ONLY, 42" X 3" WITH YELLOW REFLECTIVE DOT | 3007983 [2193578] |
| METAL DELINEATOR BASE - PERMANENT MOUNT | 3007302 [2057576] |
| DELINEATOR BASE CLAMP 8" - PERMANENT MOUNT | 3006196 [0102468] |
| YELLOW REFLECTIVE DOT ONLY, NO POST INCLUDED 2-7/8" | 3008121 [2195902] |



Shown in image: #3007649 - TrailBoss Drum, #3007669 - 25 LB Base

TRAILBLAZER™ VERTICAL PANEL



Shown left
#3007677 (top) and
#3007674 (base)

Engineer Grade or Hi-Intensity reflective sheeting available. Only weighs 3.4 lbs sheeted excluding rubber base. Stackable. Extreme heat and cold weather durability. Recessed panels protect reflective sheeting. Impact resistant polyethylene. 15 lb, 20 lb and 30 lb recycled rubber bases available.

| DESCRIPTION | PART # |
|--|-------------------|
| NO SHEETING, TOP ONLY | 3007676 [2161003] |
| ENGINEER GRADE SHEETING, BOTH SIDES, TOP ONLY | 3007677 [2161004] |
| ENGINEER GRADE 3M SHEETING, BOTH SIDES, TOP ONLY | 3007678 [2161005] |
| HI INTENSITY SHEETING, BOTH SIDES, TOP ONLY | 3007679 [2161006] |
| 15 LB RUBBER BASE, 18.5"W X 22"L X 1.3"H | 3007681 [2161008] |
| 20 LB RUBBER BASE, 18.5"W X 22"L X 1.8"H | 3007674 [2161001] |
| 30 LB RUBBER BASE, 18.5W X 22"L X 2.6"H | 3007675 [2161002] |

TRAILBOSS™ CHANNELIZER DRUM



Shown left
#3007649 (top) and
#3007668 (base)

Accommodates most barricade lights. Patented handle design allows for easy pickup. Five panels available for sheeting. Choice of two bases: 25 lb. and 35 lb. recycled rubber. Anti-roll foot design. Base incorporates a waffle pattern on bottom to eliminate 'walking' or 'creeping'. Tapered design enables nesting for storage or transportation. Dimensions - 39.7"H x 20.5"W at base. 1600 models are constructed of linear low density polyethylene. 1610 models are constructed of high density polyethylene.

| DESCRIPTION | PART # |
|--|-------------------|
| 1600 TOP ONLY, 4 ENGINEER GRADE 4" STRIPES, 3M | 3007649 [2110001] |
| 1600 TOP ONLY, 4 ENGINEER GRADE 6" STRIPES, 3M | 3007650 [2110002] |
| 1600 TOP ONLY, 4 HI INTENSITY, 4" STRIPES, 3M | 3007652 [2110004] |
| 1600 TOP ONLY, 4 HI INTENSITY 6" STRIPES, 3M | 3007654 [2110006] |
| 1610 TOP ONLY, 4 ENGINEER GRADE 4" STRIPES, 3M | 3007658 [2110101] |
| 1610 TOP ONLY, 4 ENGINEER GRADE 6" STRIPES, 3M | 3007659 [2110102] |
| 1610 TOP ONLY, 4 HI INTENSITY 4" STRIPES, 3M | 3007661 [2110104] |
| 25 LB RECYCLED RUBBER BASE | 3007668 [2111001] |
| 35 LB RECYCLED RUBBER BASE | 3007669 [2111002] |

CHANNELIZER DRUM



Shown left
#3007442 (top) and
#3007725 (base)

Accommodates most barricade lights. Unique anti-roll drum design with one flat side. Base incorporates waffle pattern on bottom to eliminate 'walking' or 'creeping'. Tapered design enables nesting for storage or transport. 1500 models are constructed of linear low density polyethylene. 1510 models are constructed of high density polyethylene.

| DESCRIPTION | PART # |
|--|-------------------|
| 1500 TOP ONLY WITH 4 ENGINEER GRADE 4" STRIPES, 3M | 3007442 [2070188] |
| 1500 TOP ONLY WITH 4 ENGINEER GRADE 6" STRIPES, 3M | 3007443 [2070190] |
| 1500 TOP ONLY WITH 4 DIAMOND GRADE 6" STRIPES | 3008629 [2204715] |
| 1500 TOP ONLY WITH 4 HI INTENSITY 4" STRIPES, 3M | 3007439 [2070165] |
| 1500 TOP ONLY WITH 4 HI INTENSITY 6" STRIPES, 3M | 3007441 [2070177] |
| 1500 PLASTIC SNAP ON BASE (REQUIRES SANDBAG) | 3001773 [2070413] |
| 1510 TOP ONLY WITH 4 ENGINEER GRADE 4" STRIPES, 3M | 3007444 [2070229] |
| 1510 TOP ONLY WITH 4 ENGINEER GRADE 6" STRIPES, 3M | 3007450 [2070231] |
| 1510 TOP ONLY WITH 4 HI INTENSITY 4" STRIPES, 3M | 3007446 [2070206] |
| 1510 TOP ONLY WITH 4 HI INTENSITY 6" STRIPES, 3M | 3007448 [2070218] |
| 25 LB RECYCLED RUBBER BASE | 3007725 [2173459] |
| 35 LB RECYCLED RUBBER BASE | 3007605 [2088262] |

WOOD/STEEL BARRICADES



TYPE 1 AND TYPE 2 BARRICADES

Rugged steel and plywood materials. 1/2" ACX plywood dipped in white water-based latex paint. Durable, weather resistant 12 gauge galvanized steel legs.

| DESCRIPTION | PART # |
|---|-------------------|
| TYPE 1 | |
| TYPE 1, 24" X 8" X 6" | 3007864 [2181043] |
| TYPE 1, 36" X 8" X 6" | 3007865 [2181044] |
| TYPE 2 | |
| TYPE 2, 24" X 8" X 8" | 3007866 [2181045] |
| TYPE 2, 36" X 6" X 6" | 3007867 [2181046] |
| REPLACEMENT LEG 12 GAUGE, SINGLE LEG | 3007868 [2181047] |

PLASTIC BARRICADES

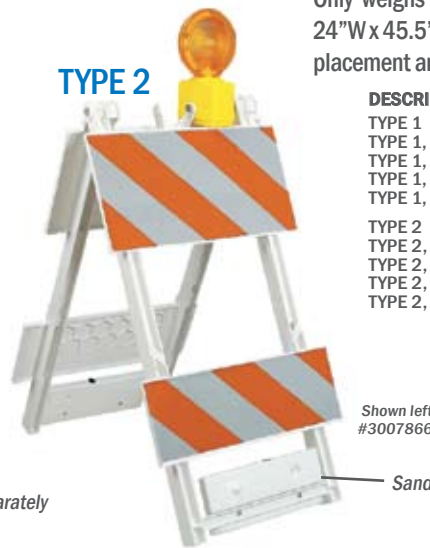

TYPE 1 AND TYPE 2 BARRICADES

Only weighs 15 lbs. Low profile - folded dimensions are 2.5"H x 24"W x 45.5"L. Closed hinge feature prevents pinched fingers during placement and retrieval.

| DESCRIPTION | PART # |
|---|-------------------|
| TYPE 1 | |
| TYPE 1, 24" X 8" X 8", EG SHEETING | 3001783 [2181000] |
| TYPE 1, 24" X 8" X 8", HI INTENSITY SHEETING | 3007828 [2181001] |
| TYPE 1, 24" X 12" X 8", EG SHEETING | 3007829 [2181002] |
| TYPE 1, 24" X 12" X 8", HI INTENSITY SHEETING | 3007830 [2181003] |
| TYPE 2 | |
| TYPE 2, 24" X 8" X 8", EG SHEETING | 3007831 [2181005] |
| TYPE 2, 24" X 8" X 8", HI INTENSITY SHEETING | 3007832 [2181006] |
| TYPE 2, 24" X 12" X 8", EG SHEETING | 3007833 [2181007] |
| TYPE 2, 24" X 12" X 8", HI INTENSITY SHEETING | 3007834 [2181008] |

Barricade lights sold separately

Sand ballast system (sold separately)

BARRICADE ACCESSORIES



SAND BALLAST SYSTEM

Used as a weight with Type 1 & 2 plastic barricades only. Unique alternative to sandbags. Adds up to 10 lbs of ballast with hollow high impact plastic panel that can be filled with sand or water. 5.75" x 15" panels, sold as a set of 2. Mounts with two bolts and nuts (included) to barricade legs below lower panel for low profile fit (shown above).

| DESCRIPTION | PART # |
|---------------------|-------------------|
| SAND BALLAST SYSTEM | 3007835 [2181009] |

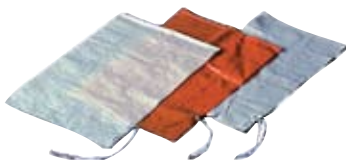

SANDBAGS

Used as a weight with Type 1 Barricades only. Hemmed top polypropylene sandbags have tie cord attached. Orange UV rating: 1,200 hours. White UV rating: 500 hours. Mildew resistant. Sold in bundles of 100 only. 10 lbs. per bundle.

| DESCRIPTION | PART # |
|--|-------------------|
| SANDBAG - WHITE 14" X 26", HOLDS UP TO 40 LBS | 3006693 [0119174] |
| SANDBAG - ORANGE 14" X 26", HOLDS UP TO 40 LBS | 3007298 [2057320] |
| SANDBAG - WHITE 18" X 27", HOLDS UP TO 50 LBS | 3007297 [2057318] |
| SANDBAG - ORANGE 18" X 27", HOLDS UP TO 50 LBS | 3007299 [2057332] |

PLASTIC A-FRAME BARRICADE

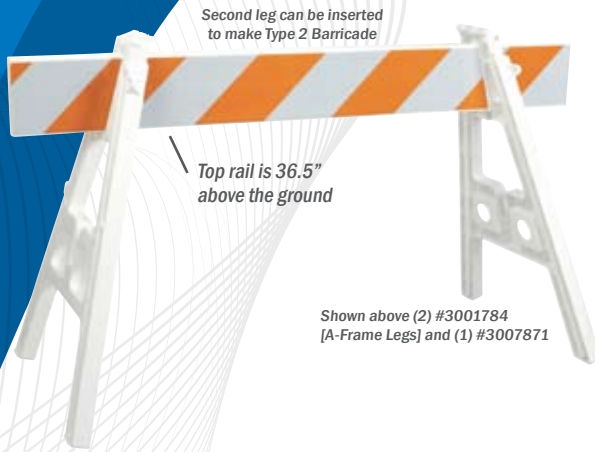

Impact-resistant polypropylene is weather resistant in extreme conditions. Barricade can be Type 1 (single rail) or Type 2 (2 rails). Rails are reinforced to resist bowing in hot weather conditions and are angled at 15° for greater stability. Lightweight and easy to handle with reflective sheeting for maximum adhesion. Individual leg weighs 6 lbs. each.

DESCRIPTION

- PLASTIC BARRICADE A-FRAME LEG - SINGLE LEG
- PLASTIC BARR 2" X 6' RAIL, NON-REFLECTIVE
- PLASTIC BARR 2" X 6' RAIL, EG SHEETING - 2 SIDES
- PLASTIC BARR 2" X 6' RAIL, HI SHEETING - 2 SIDES
- PLASTIC BARR 2" X 8' RAIL, NON-REFLECTIVE
- PLASTIC BARR 2" X 8' RAIL, EG SHEETING - 2 SIDES
- PLASTIC BARR 2" X 8' RAIL, HI SHEETING - 2 SIDES

PART #

- 3001784 [2181048]
- 3007869 [2181049]
- 3007871 [2181051]
- 3007873 [2181053]
- 3007874 [2181055]
- 3007876 [2181057]
- 3007878 [2181059]

Shown above (2) #3001784 [A-Frame Legs] and (1) #3007871

UNIQUE DUAL USE

A-Frame legs can be joined with hinge pin (included) to use as rigid sign stand.



Shown above (2) #3001784 [A-Frame Legs] and (1) #3006225 [Stop/Slow paddle]



Shown in image:
 #3007833 - Plastic Type 2 Barricades
 #3004280 - W Series Traffic Cone
 #3012872 - Class 2 Two-Tone deluxe orange vest
 #3012874 - Class 2 Two-Tone deluxe lime vest

trafficsafety



NEW

L.E.D. SUNDOWNER®

MEETS MUTCD STANDARDS AND ITE CERTIFICATION



trafficsafety

*90° angle lens*

New configurations operates with 4 D-cell batteries. 3-Way (flashing, steady burn, off) L.E.D. lights located in the strongest area of the case for protection. Simple, one piece battery compartment with battery contacts that work with gravity for greater conductivity. Durable protected L.E.D. lighting assembly with break away features during impact. A case housing, with proven durability, and a neck that is almost unbreakable. Standard Pack: 10

| DESCRIPTION | PART # |
|---|---------|
| SUNDOWNER - AMBER BODY / AMBER LENS | 3019298 |
| BOLT KIT (10 BOLTS, 1 WRENCH, 1 WIRE KEY) | 3019496 |
| AMBER L.E.D. AND HOLDER (STD PK 10) | 3019833 |
| REPLACEMENT AMBER LENS (SET OF 2) | 3019834 |
| REPLACEMENT CIRCUIT PLATE (STD PK 10) | 3019499 |
| REPLACEMENT WRENCH (STD PK 10) | 3019497 |
| REPLACEMENT WIRE KEY (STD PK 100) | 3019498 |

NEW

NIGHTFLASHER*



6V battery (not included) configuration. 7" polycarbonate lens. Dependable circuitry coated for protection against weather. Standard Pack: 10 (*Parts are not interchangeable with old light)

| DESCRIPTION | PART # |
|---|---------|
| NIGHTFLASHER - AMBER BODY/AMBER LENS | 3016221 |
| BOLT KIT (10 BOLTS, 1 WRENCH, 1 WIRE KEY) | 3019496 |
| REPLACEMENT AMBER LENS | 2005495 |
| REPLACEMENT CIRCUIT PLATE (STD PK 10) | 2005254 |
| REPLACEMENT WRENCH (STD PK 10) | 3019497 |
| REPLACEMENT WIRE KEY (STD PK 100) | 3019498 |

NEW

PARALTA*



6V battery (not included) configuration. 7" polycarbonate lens. High density polyethylene case, UV stabilized. Standard Pack: 10 (*Parts are not interchangeable with old light)

| DESCRIPTION | PART # |
|---|---------|
| PARALTA - AMBER BODY/AMBER LENS | 3016222 |
| BOLT KIT (10 BOLTS, 1 WRENCH, 1 WIRE KEY) | 3019496 |
| REPLACEMENT AMBER LENS | 2005495 |
| REPLACEMENT CIRCUIT PLATE (STD PK 10) | 2005254 |
| REPLACEMENT WRENCH (STD PK 10) | 3019497 |
| REPLACEMENT WIRE KEY (STD PK 100) | 3019498 |

STANDARD LEGEND ROAD SIGNS

Available in 1-2 business days



SPECIALITY LEGEND ROAD SIGNS

Available in 5-7 business days



CUSTOM IMPRINTING

Order special legends for your roll-up signs for an additional fee. Please allow 2-3 weeks lead time for initial orders. Contact Customer Service for pricing and ordering information at (800) 428-8185. Film charge and minimum order quantities may apply.



ROLL-UP SIGNS



Fluorescent roll-up signs that convert non-visible, ultra-violet energy into visible light are being used in increasing numbers within traffic control work zones. Fluorescent materials are most effective between dusk and dawn, when natural sources of illumination are reduced. Marathon, Super Bright and 3M Diamond Grade sign materials qualify as fluorescent, retro-reflective roll-up signs per MUTCD specifications.

SEE PAGE 123 FOR SIGN RIB OPTIONS

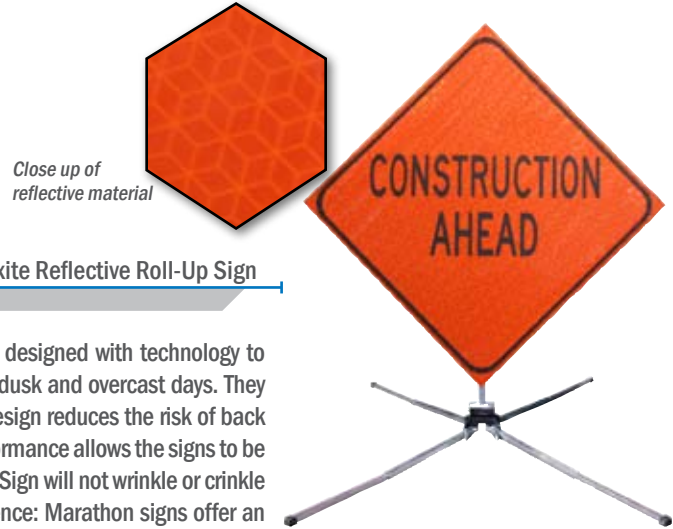

MARATHON ROLL-UP SIGN

Reflexite Reflective Roll-Up Sign

36" or 48" lightweight roll-up signs that utilize Marathon Fluorescence, designed with technology to increase sign detection, especially in low light conditions such as dawn, dusk and overcast days. They are easier to transport and only weigh 8 lbs! An ergonomically friendly design reduces the risk of back injuries during set up or take down of signs. Long lasting photometric performance allows the signs to be used longer while providing outstanding nighttime guidance to motorists. Sign will not wrinkle or crinkle and will maintain it's legibility after multiple uses. Purchase with confidence: Marathon signs offer an unprecedented 3 year warranty on the material!

| DESCRIPTION | 36" SIGN | 48" SIGN |
|----------------------|----------|----------|
| BE PREPARED TO STOP | 3016039 | 3016032 |
| CONSTRUCTION AHEAD | 3017626 | 3017652 |
| DETOUR AHEAD | 3017623 | 3017649 |
| END ROAD WORK | 3017673 | 3017675 |
| FLAGGER AHEAD | 3017624 | 3017650 |
| FLAGGER AHEAD SYMBOL | 3016040 | 3016033 |
| FRESH OIL | 3017645 | 3017674 |
| MEN WORKING | 3016041 | 3016034 |
| MEN WORKING SYMBOL | 3017630 | 3017657 |
| MERGE LEFT SYMBOL | 3017646 | 3017655 |
| MERGE RIGHT | 3017627 | 3017653 |
| MERGE RIGHT SYMBOL | 3017628 | 3017654 |
| MOWING AHEAD | 3017631 | 3017658 |
| ONE LANE ROAD AHEAD | 3017633 | 3017660 |

| DESCRIPTION | 36" SIGN | 48" SIGN |
|-------------------------|----------|----------|
| RIGHT LANE CLOSED AHEAD | 3016042 | 3016035 |
| RIGHT SHOULDER CLOSED | 3017634 | 3017661 |
| ROAD CLOSED AHEAD | 3017635 | 3017662 |
| ROAD CONSTRUCTION AHEAD | 3017636 | 3017663 |
| ROAD WORK AHEAD | 3017647 | 3017664 |
| SHOULDER WORK AHEAD | 3016038 | 3016031 |
| SIGNAL WORK AHEAD | 3017638 | 3017666 |
| SLOW | 3017639 | 3017667 |
| SURVEY CREW | 3017640 | 3017668 |
| SURVEY CREW AHEAD | 3017641 | 3017669 |
| TRUCKS ENTERING HIGHWAY | 3017676 | 3017677 |
| UTILITY WORK AHEAD | 3016037 | 3016030 |
| WORK AREA AHEAD | 3017643 | 3017671 |
| WORKERS AHEAD | 3017644 | 3017672 |

| DESCRIPTION | OVERLAYS [36"] | OVERLAYS [48"] |
|-------------------|----------------|----------------|
| 500 FT | 3016512 | 3016519 |
| 1000 FT | 3016513 | 3016520 |
| 1500 FT | 3017689 | 3016521 |
| 1/2 MILE | 3017691 | 3016522 |
| 1 MILE | 3017692 | 3016523 |
| BLANK | 3017738 | 3016517 |
| CENTER | 3016509 | 3016515 |
| DIRECTIONAL ARROW | 3016511 | 3016518 |
| LEFT | 3016508 | 3016514 |
| ONE | 3016510 | 3016516 |

SUPER BRIGHT ROLL-UP SIGN

Reflexite Reflective Roll-Up Sign

Fluorescent orange color provides maximum visibility. Fluorescent orange micro prismatic sheeting increases legibility and provides higher reflective performance. Features vinyl-coated nylon pocket design.

| DESCRIPTION | 36" SIGN | 48" SIGN |
|-------------------------|----------|----------|
| BE PREPARED TO STOP | 3008372 | 3008452 |
| DETOUR AHEAD | 3008385 | 3008463 |
| FLAGGER AHEAD | 3008352 | 3008424 |
| FLAGGER SYMBOL | 3008358 | 3008431 |
| CONSTRUCTION AHEAD | 3008380 | 3008459 |
| MERGE RIGHT | 3008415 | 3008493 |
| MERGE RIGHT SYMBOL | 3008416 | 3008492 |
| MERGE LEFT SYMBOL | 3008417 | 3008494 |
| MEN WORKING | 3008364 | 3008445 |
| MEN WORKING SYMBOL | 3008367 | 3008450 |
| MOWING AHEAD | 3008391 | 3008466 |
| RIGHT LANE CLOSED AHEAD | 3008398 | 3008469 |
| ONE LANE ROAD AHEAD | 3008392 | 3008468 |
| RIGHT SHOULDER CLOSED | 3008409 | 3008483 |

| DESCRIPTION | 36" SIGN | 48" SIGN |
|-------------------------|----------|----------|
| ROAD CLOSED AHEAD | 3008404 | 3008475 |
| ROAD CONSTRUCTION AHEAD | 3008405 | 3008478 |
| ROAD WORK AHEAD | 3008408 | 3008479 |
| SHOULDER WORK AHEAD | 3008410 | 3008486 |
| SIGNAL WORK AHEAD | 3008400 | 3008472 |
| SLOW | 3008411 | 3008487 |
| SURVEY CREW | 3008413 | 3008488 |
| SURVEY CREW AHEAD | 3009113 | 3008489 |
| UTILITY WORK AHEAD | 3008418 | 3008498 |
| WORK AREA AHEAD | 3008401 | 3008474 |
| WORKERS AHEAD | 3008414 | 3008491 |
| FRESH OIL | 3008423 | 3008500 |
| END ROAD WORK | 3008816 | 3008811 |
| TRUCKS ENTERING HIGHWAY | 3008381 | 3008458 |

| DESCRIPTION | OVERLAYS [36"] | OVERLAYS [48"] |
|-------------------|----------------|----------------|
| LEFT | 3008689 | 3008691 |
| CENTER | 3008694 | 3008695 |
| ONE | 3008696 | 3008697 |
| BLANK | 3008698 | 3008700 |
| DIRECTIONAL ARROW | 3008701 | 3008712 |
| 500 FT | 3008713 | 3008714 |
| 1000 FT | 3008715 | 3008716 |
| 1500 FT | 3008717 | 3008718 |
| 1/2 MILE | 3008720 | 3008721 |
| 1 MILE | 3008722 | 3008723 |

DIAMOND GRADE ROLL-UP SIGN

3M Reflective Roll-Up Sign

Fluorescent orange color provides maximum visibility. Allows for increased angularity for enhanced nighttime performance. Features vinyl-coated nylon pocket design.

| DESCRIPTION | 36" SIGN | 48" SIGN |
|-------------------------|----------|----------|
| BE PREPARED TO STOP | 3008513 | 3008563 |
| DETOUR AHEAD | 3008515 | 3008567 |
| FLAGGER AHEAD | 3008502 | 3008539 |
| FLAGGER SYMBOL | 3008503 | 3008543 |
| CONSTRUCTION AHEAD | 3008514 | 3008566 |
| MERGE RIGHT | 3008535 | 3008599 |
| MERGE RIGHT SYMBOL | 3008536 | 3008603 |
| MEN WORKING | 3008509 | 3008546 |
| MEN WORKING SYMBOL | 3008510 | 3008555 |
| MOWING AHEAD | 3008516 | 3008568 |
| RIGHT LANE CLOSED AHEAD | 3008518 | 3008573 |
| ONE LANE ROAD AHEAD | 3008517 | 3008572 |
| RIGHT SHOULDER CLOSED | 3008529 | 3008586 |

| DESCRIPTION | 36" SIGN | 48" SIGN |
|-------------------------|----------|----------|
| ROAD CLOSED AHEAD | 3008523 | 3008580 |
| ROAD CONSTRUCTION AHEAD | 3008526 | 3008582 |
| SHOULDER WORK AHEAD | 3008530 | 3008588 |
| SIGNAL WORK AHEAD | 3008520 | 3008577 |
| SLOW | 3008531 | 3008592 |
| SURVEY CREW | 3008532 | 3008595 |
| SURVEY CREW AHEAD | 3008533 | 3008813 |
| UTILITY WORK AHEAD | 3008537 | 3008609 |
| WORK AREA AHEAD | 3008521 | 3008578 |
| WORKERS AHEAD | 3008534 | 3008596 |
| FRESH OIL | 3008538 | 3008610 |
| END ROAD WORK | 3008818 | 3008812 |

| DESCRIPTION | OVERLAYS [36"] | OVERLAYS [48"] |
|-------------------|----------------|----------------|
| LEFT | 3008725 | 3008726 |
| CENTER | 3008727 | 3008728 |
| ONE | 3008729 | 3008730 |
| BLANK | 3008731 | 3008732 |
| DIRECTIONAL ARROW | 3008733 | 3008734 |
| 500 FT | 3008735 | 3008736 |
| 1000 FT | 3008737 | 3008738 |
| 1500 FT | 3014670 | 3008739 |
| 1/2 MILE | N/A | 3008740 |
| 1 MILE | 3015190 | 3008743 |

KS SINGLE PLY ROLL-UP SIGN

NON-REFLECTIVE ROLL-UP SIGN

Fabricated from single ply, vinyl-coated nylon mesh with vinyl bound edges for greater durability. Brilliant red/orange color provides excellent visibility. Legends and borders are heat sealed using black vinyl material. Features vinyl-coated nylon pocket design.

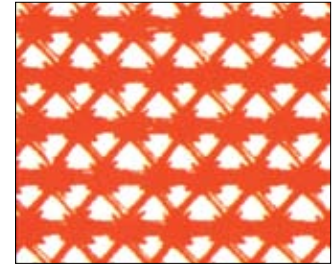

| DESCRIPTION | 36" SIGN | 48" SIGN |
|-------------------------|----------|----------|
| BE PREPARED TO STOP | 3008199 | 3008211 |
| DETOUR AHEAD | 3008200 | 3008212 |
| FLAGGER AHEAD | 3006295 | 3006341 |
| FLAGGER SYMBOL | 3006317 | 3006365 |
| CONSTRUCTION AHEAD | 3006297 | 3006346 |
| MERGE RIGHT | 3008208 | 3008223 |
| MERGE RIGHT SYMBOL | 3007460 | 3007462 |
| MERGE LEFT SYMBOL | 3007461 | 3007463 |
| MEN WORKING | 3007385 | 3006339 |
| MEN WORKING SYMBOL | 3006296 | 3006343 |
| MOWING AHEAD | 3008201 | 3008213 |
| RIGHT LANE CLOSED AHEAD | 3008226 | 3008216 |
| ONE LANE ROAD AHEAD | 3008202 | 3008214 |
| RIGHT SHOULDER CLOSED | 3008204 | 3008218 |
| ROAD CLOSED AHEAD | 3007386 | 3007389 |

| DESCRIPTION | 36" SIGN | 48" SIGN |
|-------------------------|----------|----------|
| ROAD CONSTRUCTION AHEAD | 3006300 | 3006353 |
| ROAD WORK AHEAD | 3006322 | 3006368 |
| SHOULDER WORK AHEAD | 3008205 | 3008219 |
| SIGNAL WORK AHEAD | 3008203 | 3008217 |
| SLOW | 3008206 | 3008221 |
| SURVEY CREW AHEAD | 3006328 | 3006387 |
| SURVEY CREW | 3006334 | 3006384 |
| UTILITY WORK AHEAD | 3006336 | 3006389 |
| WORK AREA AHEAD | 3006306 | 3006359 |
| WORKERS AHEAD | 3008207 | 3008222 |
| PADDLE SYMBOL | 3008198 | 3008210 |
| FRESH OIL | 3008209 | 3008224 |
| END ROAD WORK | 3009203 | 3006362 |
| TRUCKS ENTERING HIGHWAY | 3006299 | 3009106 |

| DESCRIPTION | OVERLAYS [36"] | OVERLAYS [48"] |
|-------------------|----------------|----------------|
| LEFT | 3008634 | 3008637 |
| CENTER | 3008638 | 3008642 |
| ONE | 3008643 | 3008644 |
| BLANK | 3008645 | 3008646 |
| DIRECTIONAL ARROW | 3008647 | 3008648 |
| 500 FT | 3008650 | 3008651 |
| 1000 FT | 3008652 | 3008653 |
| 1500 FT | 3008654 | 3008655 |
| 1/2 MILE | 3008656 | 3008657 |
| 1 MILE | 3008658 | 3008659 |

KS DOUBLE PLY ROLL-UP SIGN

NON-REFLECTIVE ROLL-UP SIGN

Constructed with two layers of heavy duty, double knit, nylon mesh material. Brilliant red/orange color provides excellent visibility. Legends and borders are heat sealed using black vinyl material. Features vinyl-coated nylon pocket design.



| DESCRIPTION | 36" SIGN | 48" SIGN |
|-------------------------|----------|----------|
| BE PREPARED TO STOP | 3008227 | 3008241 |
| DETOUR AHEAD | 3008228 | 3008242 |
| FLAGGER AHEAD | 3006398 | 3006467 |
| FLAGGER SYMBOL | 3006410 | 3006479 |
| CONSTRUCTION AHEAD | 3006402 | 3006473 |
| MERGE RIGHT | 3008238 | 3008254 |
| MERGE RIGHT SYMBOL | 3007464 | 3007468 |
| MERGE LEFT SYMBOL | 3007466 | 3007469 |
| MEN WORKING | 3007383 | 3006464 |
| MEN WORKING SYMBOL | 3006400 | 3006470 |
| MOWING AHEAD | 3008229 | 3008243 |
| RIGHT LANE CLOSED AHEAD | 3008231 | 3008246 |
| ONE LANE ROAD AHEAD | 3008230 | 3008244 |
| RIGHT SHOULDER CLOSED | 3008234 | 3008250 |
| ROAD CLOSED AHEAD | 3007384 | 3008248 |

| DESCRIPTION | 36" SIGN | 48" SIGN |
|-------------------------|----------|----------|
| ROAD CONSTRUCTION AHEAD | 3006405 | 3006477 |
| ROAD WORK AHEAD | 3006412 | 3006480 |
| SHOULDER WORK AHEAD | 3008235 | 3008251 |
| SIGNAL WORK AHEAD | 3008233 | 3008247 |
| SLOW | 3008236 | 3008252 |
| SURVEY CREW | 3006427 | 3006494 |
| SURVEY CREW AHEAD | 3006436 | 3006495 |
| UTILITY WORK AHEAD | 3006460 | 3007387 |
| WORK AREA AHEAD | 3006406 | 3006478 |
| WORKERS AHEAD | 3008237 | 3008253 |
| PADDLE SYMBOL | 3008256 | 3008240 |
| FRESH OIL | 3008239 | 3008255 |
| END ROAD WORK | 3007919 | 3007918 |
| TRUCKS ENTERING HIGHWAY | 3009198 | 3009189 |

| DESCRIPTION | OVERLAYS [36"] | OVERLAYS [48"] |
|-------------------|----------------|----------------|
| LEFT | 3008634 | 3008637 |
| CENTER | 3008638 | 3008642 |
| ONE | 3008643 | 3008644 |
| BLANK | 3008645 | 3008646 |
| DIRECTIONAL ARROW | 3008647 | 3008648 |
| 500 FT | 3008650 | 3008651 |
| 1000 FT | 3008652 | 3008653 |
| 1500 FT | 3008654 | 3008655 |
| 1/2 MILE | 3008656 | 3008657 |
| 1 MILE | 3008658 | 3008659 |



VS MESH ROLL-UP SIGN

NON-REFLECTIVE ROLL-UP SIGN

Manufactured from tightly woven polyester fabric. Specially formulated PVC foam extruded over polyester yarn for a roll-up panel at a very competitive price. Features vinyl-coated nylon pocket design. Lexan pockets available upon request at an additional cost. Silk screened legends and borders.

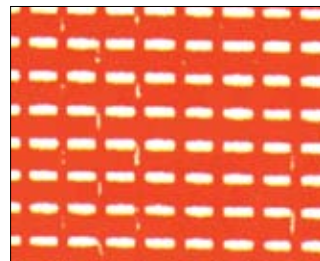

| DESCRIPTION | 36" SIGN | 48" SIGN |
|-------------------------|----------|----------|
| BE PREPARED TO STOP | 3008258 | 3008273 |
| DETOUR AHEAD | 3008259 | 3008274 |
| FLAGGER AHEAD | 3006522 | 3006544 |
| FLAGGER SYMBOL | 3006532 | 3006568 |
| CONSTRUCTION AHEAD | 3006528 | 3006555 |
| MERGE RIGHT | 3008415 | 3008269 |
| MERGE RIGHT SYMBOL | 3007470 | 3007471 |
| MERGE LEFT SYMBOL | 3008270 | 3007472 |
| MEN WORKING | 3006521 | 3006543 |
| MEN WORKING SYMBOL | 3006524 | 3006547 |
| MOWING AHEAD | 3008260 | 3008275 |
| RIGHT LANE CLOSED AHEAD | 3008262 | 3008278 |
| ONE LANE ROAD AHEAD | 3008261 | 3008277 |
| RIGHT SHOULDER CLOSED | 3008265 | 3008280 |
| ROAD CLOSED AHEAD | 3007435 | 3007347 |

| DESCRIPTION | 36" SIGN | 48" SIGN |
|-------------------------|----------|----------|
| ROAD CONSTRUCTION AHEAD | 3006529 | 3006562 |
| ROAD WORK AHEAD | 3006533 | 3006569 |
| SHOULDER WORK AHEAD | 3008266 | 3008282 |
| SIGNAL WORK AHEAD | 3008263 | 3008279 |
| SLOW | 3008267 | 3008283 |
| SURVEY CREW | 3006536 | 3006574 |
| SURVEY CREW AHEAD | 3006538 | 3006576 |
| UTILITY WORK AHEAD | 3006540 | 3006579 |
| WORK AREA AHEAD | 3006531 | 3006563 |
| WORKERS AHEAD | 3008268 | 3008284 |
| PADDLE SYMBOL | 3008257 | 3008272 |
| FRESH OIL | 3008271 | 3008286 |
| END ROAD WORK | 3008815 | 3008810 |
| TRUCKS ENTERING HIGHWAY | 3008796 | 3008797 |

| DESCRIPTION | OVERLAYS [36"] | OVERLAYS [48"] |
|-------------------|----------------|----------------|
| LEFT | 3008661 | 3008662 |
| CENTER | 3008663 | 3008664 |
| ONE | 3008665 | 3008666 |
| BLANK | 3008667 | 3008668 |
| DIRECTIONAL ARROW | 3008669 | 3008670 |
| 500 FT | 3008671 | 3008672 |
| 1000 FT | 3008673 | 3008674 |
| 1500 FT | 3008675 | 3008676 |
| 1/2 MILE | | 3008677 |
| 1 MILE | 3008678 | 3008679 |

FIBERGLASS ROLL-UP SIGN RIBS

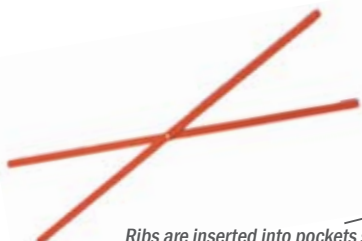

Ribs are inserted into pockets sewn on back of roll-up signs as shown

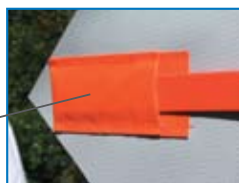

All fiberglass ribs are coated to reduce splinters and cracking. Available for 36" and 48" roll-up signs. Rib sets are determined by signstands being used.

| DESCRIPTION | PART # |
|---|-------------------|
| FIBERGLASS RIBS FOR QUADRA FLEX V™ | |
| RIBS & HARDWARE FOR 36" ROLL-UP SIGNS | 3006667 [0118388] |
| RIBS & HARDWARE FOR 48" ROLL-UP SIGNS | 3006183 [0101725] |
| FIBERGLASS RIBS (USE FOR QLV, SCREWLOCK STANDS, & UNISPRING) | |
| RIBLOCK SET 36" | 2004580 [2080377] |
| RIBLOCK SET 48" | 2004581 [2080389] |
| STANDARD FIBERGLASS RIBS (USE FOR A-FRAME, TRI-POD & T-STAND) | |
| RIBS FOR 36" ROLL-UP SIGNS | 3006684 [0118936] |
| RIBS FOR 48" ROLL-UP SIGNS | 3006685 [0118948] |

QUADRA FLEX V™ KITS



71" footprint when fully extended

EXCLUSIVE TO JACKSON SAFETY! Unique spring-loaded QFV sign stands display 36" or 48" roll-up panels a minimum of 14" off the ground. Patented spring design incorporates anti-rotational device. Exclusive base, spring and leg design absorbs winds up to 50 mph. Unique kick-lock release lever allows leg unfolding and adjusting to uneven terrain. Durable, lightweight and corrosion-resistant aluminum legs provide longer service life and easier handling. Quick lock mast allows for easy panel set-up/take-down. Velcro strap-on mast prevents panel from windmilling. Four steel L-shaped brackets reinforce legs to base. Telescoping aluminum legs provide maximum stability. Kits include: base, mast, ribs and flags.

| DESCRIPTION | PART # |
|---|-------------------|
| QUADRA FLEX V™ KIT FOR 36" SIGN | 3007536 [2083673] |
| QUADRA FLEX V™ KIT FOR 48" SIGN | 3007535 [2083660] |
| QUADRA FLEX V™ BASE | 3006686 [0119045] |
| QUADRA FLEX V™ BASE & MAST FOR 48" ROLL-UP SIGN | 3006172 [0101490] |
| QUADRA FLEX V™ BASE & TELESCOPING MAST | 3006174 [0101517] |
| QUADRA FLEX V™ 60 (BASE & MAST ONLY) | 3006173 [0101505] |
| QUADRA FLEX V™ MAST FOR 36" ROLL-UP SIGN | 3006184 [0101763] |
| QUADRA FLEX V™ MAST FOR 48" ROLL-UP SIGN | 3006185 [0101775] |
| QUADRA FLEX V™ TELESCOPING MAST | 3006186 [0101787] |
| ADAPTER FOR RIGID AND SEMI-RIGID SIGNS | 3007381 [2059665] |

UNISPRING 2000 SIGN



Screwlock

NCHRP-350 Certified. Complies with MUTCD standards. Features versatile, compact single-coil spring. Ease of use with fast kick release system, locking legs into place when fully extended. Displays 36" and 48" reflective roll-up signs using ScrewLock™ attachment. All aluminum and steel construction. Telescoping aluminum legs with two position height adjustment and anti-skid foot pads. Minimum height from ground to bottom panel: 12" (305 mm). Ribs sold separately.

| DESCRIPTION | PART # |
|---------------------------|-------------------|
| UNISPRING 2000 SIGN STAND | 3006176 [0101568] |

QFV-W SPRING LOADED SCREWLOCK

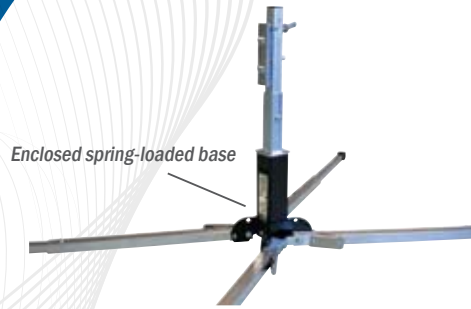

EXCLUSIVE TO JACKSON SAFETY! Unique spring-loaded QFV sign stands display 36" and 48" roll-up panels at minimum of 14" off the ground. Patented spring design incorporates anti-rotational device with an exclusive base, spring and leg design absorbs winds up to 50 mph. Unique kick-lock release lever allows telescoping legs to unfold and adjust in uneven terrain. Holds virtually any fiberglass rib sign panel without adaptation or retrofit. Vertical panel rib slips into 'J' channel bracket and is held securely by swivel pad and threaded shaft.

| DESCRIPTION | PART # |
|--|-------------------|
| QFV-W SCREWLOCK™ (BASE ONLY) | 3007816 [2180191] |
| QFV-W SCREWLOCK™ KIT FOR 36" ROLL-UP SIGNS | 3008789 [2210374] |
| QFV-W SCREWLOCK™ KIT FOR 48" ROLL-UP SIGNS | 3008790 [2210386] |

QLV-W SCREWLOCK

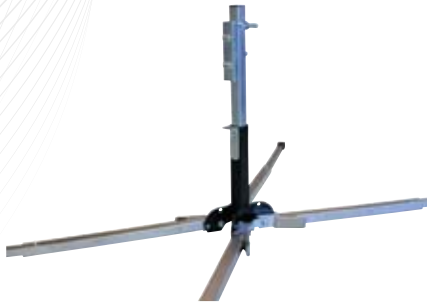

Allows the user to hold virtually any fiberglass rib sign panel without adaptation or retrofit. Sign stand displays 36" and 48" roll-up panels, 81.5" off the ground. Vertical panel rib slips into 'J' channel bracket and is held in place by a swivel pad and threaded shaft. Fold-down telescoping legs using kick-lock release levers. Legs adjust for uneven terrain. Durable, lightweight and corrosion-resistant aluminum legs provide longer service life and easier handling. Four steel L-shaped brackets reinforce legs and base.

| DESCRIPTION | PART # |
|--|-------------------|
| QLV-W SCREWLOCK™ (BASE ONLY) | 3007814 [2180177] |
| QLV-W SCREWLOCK™ KIT FOR 36" ROLL-UP SIGNS | 3008152 [2198124] |
| QLV-W SCREWLOCK™ KIT FOR 48" ROLL-UP SIGNS | 3008153 [2198136] |

QFV-84 SIGN STAND



EXCLUSIVE TO JACKSON SAFETY! Displays 48" roll-up signs 7 feet off the ground. System includes base assembly with wind relieving spring and two-stage mast with sign panel holder. Legs feature a locking pin with spring-loaded release device for quick set-up and take-down operations.

| DESCRIPTION | PART # |
|--------------------|-------------------|
| QFV-84 BASE & MAST | 3008819 [2211134] |

DYNAFLEX 4000™



Roll-up panel bracket allows for a quick switch from 36" to 48" roll-up sign. Dual torsion spring system absorbs winds up to 50 mph. Open footprint: 90" x 52", Leg length: 54.5", Weight: 29 lbs, Storage height: 54.5"

| DESCRIPTION | PART # |
|-------------------|-------------------|
| DF4000 SIGN STAND | 3007815 [0119077] |



EMERGENCY RESPONSE FOLD AND ROLL



Compact design for minimal storage and easy transportation. Quick and easy set-up. Aluminum and steel construction. Sign made from fluorescent pink coral material. Telescoping aluminum legs with two position height adjustments and anti-skid foot pads. Kick release system for quick leg deployment. Dual torsion springs to withstand wind resistance. Full extension length: 51" each leg. Open footprint: 92" x 57.5". Weight: 32 LB. Displays 48" sign with Quick-Locking Stab-lock Sign Holding System.

| DESCRIPTION | PART # |
|--|-------------------|
| F&R SIGN KIT "EMERGENCY SCENE AHEAD" | 3007274 [2031054] |
| F&R SIGN KIT "ACCIDENT AHEAD" | 3009813 [2031056] |
| F&R SIGN KIT "TRAFFIC EMERGENCY AHEAD" | 3009814 [2031057] |
| F&R SIGN CARRYING CASE | 3009815 [2031058] |

ROLL-UP/RIGID TRIPOD SIGN STAND



Meets NCHRP-350 requirements with roll-up sign. Displays 36" and 48" roll-up or rigid panels without special adaptors. Sign stands withstand winds under 30 MPH. Fabricated from durable, galvanized mechanical tubing. Strong, lightweight design allows for easy set-up and take-down.

| DESCRIPTION | PART # |
|--|-------------------|
| TRI-POD STAND FOR ROLL-UP AND RIDGID SIGNS | 3007719 [2173227] |

'T' STAND



Made of galvanized steel and built in plastic coated spring clips to accommodate roll-up signs up to 48". This product has not been crash-tested.

| DESCRIPTION | PART # |
|----------------------------|-------------------|
| 'T' STAND SIGN STAND/RIGID | 3006179 [0101581] |

ROLL-UP SIGN ACCESSORIES

| DESCRIPTION | PART # |
|---|-------------------|
| FOLDING FLAG SYSTEM | |
| FLAG ADAPTER FOR 3 FLAGS | 3007518 [2082146] |
| RIGID SIGN STAND ADAPTER FOR ROLL-UP SIGNS ON QFV | 3006664 [0118261] |
| SIGN STAND BRACKET FOR QFV-60, QFV-84, SLIP-60 | 3006665 [0118263] |
| SIGN CASES | |
| ROLL-UP SIGN CASE 36" SIGN | 3006587 [0108981] |
| ROLL-UP SIGN CASE 48" SIGN | 3006588 [0109002] |
| SPECIAL ADAPTER ALLOWS USE OF OTHER RIBS WITH OUR SIGNS | |
| SPECIAL CLAMP ONLY FOR ROLL-UP SIGNS | 3006189 [0101830] |

STOP/SLOW ABS PADDLES (PLASTIC)



Meets MUTCD requirements. Octagon shape. Paddles available silk screened (non-reflective) or reflective in Engineer, Hi-Intensity or Diamond Grade sheeting. Plastic signs are 2/16" - 3/16" thick. Letter size: 8" on 24" paddles and 6" on 18" paddles. Assembly kits include PVC handle: short 14"/long 61" adapter, both included in kits. Also accommodates 6' wood handle (sold separately).

| DESCRIPTION | PART # | DESCRIPTION | PART # |
|----------------------|-------------------|---|-------------------|
| SIGN ONLY: | | | |
| STOP/SLOW 18" | | PLASTIC SIGN ASSEMBLY KITS (STAFF AND COUPLINGS): | |
| 18" NON-REFLECTIVE | 3007366 [2058740] | STOP/SLOW 18" | |
| 18" ENGINEER GRADE | 3007364 [2058738] | 18" NON-REFLECTIVE - ABS PLASTIC HANDLES | 3007771 [2177572] |
| 18" HI-INTENSITY | 3007393 [2062399] | 18" ENGINEER GRADE - ABS PLASTIC HANDLES | 3007774 [2177675] |
| 18" DIAMOND GRADE | 3007928 [2188571] | 18" DIAMOND GRADE - ABS PLASTIC HANDLES | 3007934 [2188648] |
| STOP/SLOW 24" | | | |
| 24" NON-REFLECT | 3007368 [2058776] | STOP/SLOW 24" | |
| 24" ENGINEER GRADE | 3007370 [2058788] | 24" NON-REFLECTIVE - ABS PLASTIC HANDLES | 3007772 [2177601] |
| 24" HI-INTENSITY | 3007395 [2062416] | 24" EG SHEETING - ABS PLASTIC HANDLES | 3007773 [2177613] |
| 24" DIAMOND GRADE | 3007930 [2188583] | 24" HI-INTENSITY SHEETING - ABS PLASTIC HANDLES | 3007770 [2177558] |
| | | 24" DIAMOND GRADE - ABS PLASTIC HANDLES | 3007933 [2188636] |
| ACCESSORIES: | | | |
| | | KIT FOR PLASTIC PADDLES WITH PVC HANDLE | 3007436 [2069907] |
| | | KIT FOR ABS PADDLES WITH 6' WOOD HANDLE | 2004629 [2211600] |

STOP/SLOW ALUMINUM PADDLES

Aluminum, silk-screened octagon shaped paddles in 15" or 18" size. .080 gauge baked aluminum enamel. Available with 6" aluminum, 6" wooden or 6' wooden handles. Ideal for school crossing guards, flaggers and plant security guards. Wood handle: 6.5" short, 6" long, 7-1/8" to bottom of sign. Aluminum handle: 5-3/16", 14-7/8" to bottom of sign. Assembly kit includes paddle, handle and hardware.

| DESCRIPTION | PART # |
|---|-------------------|
| SIGN ONLY: | |
| STOP/SLOW | |
| 15" NON-REFLECTIVE | 3006224 [0103474] |
| 18" NON-REFLECTIVE | 3006225 [0103486] |
| ALUMINUM SIGN ASSEMBLY KITS (STAFF AND COUPLINGS): | |
| STOP/SLOW | |
| 15" (ALUMINUM HANDLE) | 3007351 [2058386] |
| 15" (WOOD HANDLE) | 3007352 [2058398] |
| 18" (ALUMINUM HANDLE) | 3007353 [2058403] |
| 18" (WOOD HANDLE) | 3007354 [2058415] |
| 18" (6' WOOD HANDLE) | 3007641 [2094255] |
| STOP/STOP | |
| 15" (ALUMINUM HANDLE) | 3007355 [2058556] |
| 18" (ALUMINUM HANDLE) | 3007356 [2058570] |
| ACCESSORIES | |
| HARDWARE KIT FOR ALUM PADDLES WITH SHORT ALUM HANDLE | 3008823 [2211587] |
| HARDWARE KIT FOR ALUM PADDLES WITH SHORT WOOD HANDLE | 3008822 [2211563] |
| STOP & SLOW PADDLE 6' WOOD HANDLE | 3007585 [2087352] |



STANDARD VINYL KNITTED WARNING FLAGS



Heat sealed hem. Non-fouling feature. Available with unique diagonal plastic stay which holds flag open. Vinyl-coated nylon blend material. 3/4" diameter hardwood dowel. Standard Pack: 50

| DESCRIPTION | PART # |
|---|-------------------|
| VINYL WARNING FLAG (18" FLAG / 24" DOWEL) | 3006648 [0117152] |
| VINYL WARNING FLAG (18" FLAG / 30" DOWEL) | 3006654 [0117229] |
| VINYL WARNING FLAG (18" FLAG / 36" DOWEL) | 3006651 [0117176] |
| VINYL WARNING FLAG (18" FLAG / 36" DOWEL WITH STAY) | 3006218 [0103254] |
| VINYL WARNING FLAG (18" FLAG ONLY) | 3006650 [0117164] |
| VINYL WARNING FLAG (24" FLAG / 30" DOWEL) | 3006219 [0103266] |
| VINYL WARNING FLAG (24" FLAG / 36" DOWEL) | 3006652 [0117205] |
| VINYL WARNING FLAG (24" FLAG / 36" DOWEL WITH STAY) | 3006220 [0103292] |

THROW AWAY WARNING FLAGS



Economy style. Nail or staple to overhanging load. Bright red plastic material. No hems, grommets or dowels. Standard Pack: 100/bag

| DESCRIPTION | PART # |
|----------------------------|-------------------|
| THROW AWAY FLAG - 12" FLAG | 3006197 [0102729] |
| THROW AWAY FLAG - 18" FLAG | 3006655 [0117243] |

HEAVY DUTY KNITTED WARNING FLAGS

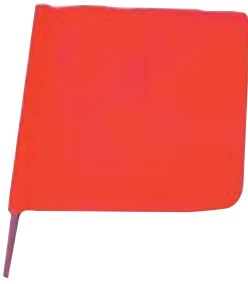

Vinyl trim. Polyester yarn covered in vinyl. Red knitted flag with vinyl trim. 3/4" diameter hard wood dowel. Standard Pack: 50

| DESCRIPTION | PART # |
|---|-------------------|
| KNITTED VINYL WARNING FLAG (18" FLAG/24" DOWEL) | 3006201 [0102822] |
| KNITTED VINYL WARNING FLAG (18" FLAG/30" DOWEL) | 3001743 [0102734] |
| KNITTED VINYL WARNING FLAG (18" FLAG/36" DOWEL) | 3006202 [0102846] |
| KNITTED VINYL WARNING FLAG (18" FLAG/NO DOWEL) | 3007303 [2057629] |
| KNITTED VINYL WARNING FLAG (24" FLAG/30" DOWEL) | 3006203 [0102858] |
| KNITTED VINYL WARNING FLAG (24" FLAG/36" DOWEL) | 3006204 [0102860] |

PLAIN WEAVE MESH WARNING FLAGS



18" x 18". Vinyl-coated mesh material. 3/4" diameter hard wood dowel. Standard Pack: 50

| DESCRIPTION | PART # |
|--|-------------------|
| MESH WARNING FLAG (18" FLAG / 24" DOWEL) | 3006205 [0102896] |
| MESH WARNING FLAG (18" FLAG / 30" DOWEL) | 3006206 [0102913] |
| MESH WARNING FLAG (18" FLAG/NO DOWEL) | 3006210 [0102951] |

FLAGMAN'S FLAG



24" flag with weighted edge. Available in silver reflective or non-reflective material. 36" long dowel. Standard Pack: 50

| DESCRIPTION | PART # |
|--|-------------------|
| WARNING FLAG - 24" FLAG (NON-REFLECTIVE) | 3006215 [0103151] |
| WARNING FLAG - 24" FLAG (REFLECTIVE) | 3006216 [0103163] |

AIRPORT FLAGS



36" x 36" nylon flag with pocket to mount on your existing staff. Alternating checkerboard 12" x 12" squares in orange and white. Sleeve opening is 2-3/4". Dowel not included.

| DESCRIPTION | PART # |
|--|-------------------|
| AIRPORT TRUCK SIGNAL FLAG, 36" X 36" ORANGE/WHITE CHECKERBOARD | 3006235 [0103644] |

WINDSOCKS



Strong vinyl-coated nylon fabric in dayglow orange color. Reinforced at both ends with extra stitching. Begins to open at 3 MPH, fully extended at 21 MPH. Windsock and hardware kits sold separately. 3' opening, 8' long, 11" opening at end.

| DESCRIPTION | PART # |
|--------------------------------|-------------------|
| AIRPORT WINDSOCK 3' X 8' X 11' | 3006697 [0119239] |
| WINDSOCK HARDWARE | 3006663 [0118209] |

SPEED BUMP



Will not warp, crack, chip or rot. Withstands 120,000 lbs. Yellow polyurethane glass-beaded paint for maximum reflectivity. Channeled bottom (two 1-1/4" channels) allows for cabling or piping and facilitates drainage. Epoxy or rebar spikes can be used to hold speed bump in place. Three rebar spikes on 48", four rebar spikes on 72" speed bumps. Spikes sold separately. Made of 100% recycled rubber.

| DESCRIPTION | PART # |
|---|-------------------|
| STRIPED SPEED BUMP 2.5" X 12" X 48" (34 LBS.) | 3007916 [2185050] |
| STRIPED SPEED BUMP 2.5" X 12" X 72" (51 LBS.) | 3007917 [2185074] |
| 14" REBAR SPIKE | 3007973 [2192326] |

PARKING CURB



Will not warp, crack, chip or rot. 1/10 the weight of concrete. Yellow polyurethane glass-beaded paint for maximum reflectivity. Resistant to UV rays, moisture, paint, oil and extreme temperature variations. Epoxy or rebar spikes can be used to hold parking curb in place. Two rebar spikes on 36", four rebar spikes on 72" parking curbs. Spikes sold separately. Made of 100% recycled rubber.

| DESCRIPTION | PART # |
|--------------------------------------|-------------------|
| PARKING CURB 4" X 6" X 36" (17 LBS.) | 3007914 [2185024] |
| PARKING CURB 4" X 6" X 72" (34 LBS.) | 3007915 [2185036] |
| 14" REBAR SPIKE | 3007973 [2192326] |

TEMPORARY PAVEMENT MARKER



1.6" square inches of reflective area on each side. For temporary use in construction zones with or in place of conventional tape. 3/4" x 4" x 4".

| DESCRIPTION | PART # |
|-------------|-------------------|
| 2 WAY AMBER | 3015594 [2078831] |
| 1 WAY AMBER | 3015592 [2078843] |
| 2 WAY WHITE | 3015595 [2078855] |
| 1 WAY WHITE | 3015593 [2078867] |

NEW

FLEXIBLE PAVEMENT MARKER



Body retains its original shape after being hit repeatedly. Working hinge and PVC body make this marker virtually vandal proof. Large reflective area.

| DESCRIPTION | PART # |
|--------------|-------------------|
| 2 WAY YELLOW | 3015583 [2186743] |
| 1 WAY YELLOW | 3015582 [2186690] |

REFLECTIVE TRUCK TAPE

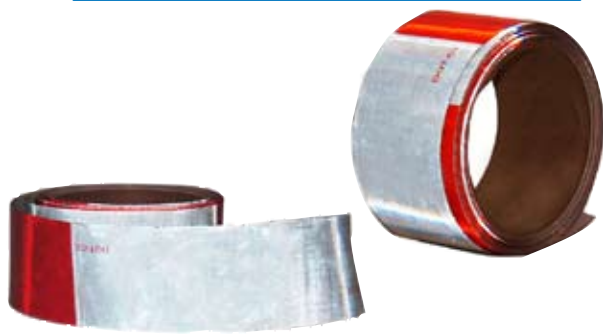

Alternating 11" red and 7" white, pressure-sensitive tape. 600 candelas bright. Utilizes Reflexite technology. Available in 2" x 50-yard rolls only

| DESCRIPTION | PART # |
|--|-------------------|
| REFLECTIVE TRUCK TAPE, 2" X 50 YARDS (RED/WHITE) | 1002225 [2079017] |

BARRIER TAPE



Provides warning of temporary safety hazards. Economical, strong and disposable. 3 inches wide x 1000 feet long x 2 mm thick. Special legends available with minimums and plate charge. Call Customer Service for details at 800-428-8185.

| DESCRIPTION | PART # |
|------------------------------------|-------------------|
| CAUTION - YELLOW | 3006620 [0110843] |
| POLICE LINE DO NOT CROSS - YELLOW | 3006627 [0111029] |
| FIRE LINE DO NOT CROSS - YELLOW | 3006625 [0110972] |
| CAUTION CONSTRUCTION AREA - YELLOW | 3006621 [0110855] |
| CAUTION DO NOT ENTER - YELLOW | 3006622 [0110867] |
| DANGER DO NOT ENTER - RED | 3006618 [0110805] |
| DANGER - RED | 3006619 [0110817] |

HIGHWAY BANNERS



Available in Wide Load, Oversize Load or Wide Load/Oversize Load, 2-sided combination. Bright yellow with 12" black letters. 18" x 8' with 5' rope ties. 10 oz. non-reflective nylon material.

| DESCRIPTION | PART # |
|-------------------------------|-------------------|
| WIDE LOAD | 3006691 [0119150] |
| OVERSIZE LOAD | 3006601 [0109820] |
| WIDE LOAD/OVERSIZE LOAD COMBO | 3006692 [0119162] |

RUBBER WHEEL CHOCK



Built to meet OSHA requirements. Designed with a friction base for maximum traction on practically any surface, wet or dry. Metal "O" hook imbedded in back. Fluted, hollow design causes downward pressure to lock chock into place. SVR rubber compound material. Available with or without 12 feet of jack chain.

| DESCRIPTION | PART # |
|--|-------------------|
| RUBBER WHEEL CHOCK NO CHAIN, 8 LBS (6"H X 10"L X 8"D) | 3006598 [0109765] |
| RUBBER WHEEL CHOCK W/ 12FT CHAIN ATTACHED (6"H X 10"L X 8"D) | 3006599 [0109777] |

SAFETY FLARES



Visible in fog, rain or snow. Easy to ignite with self-contained striker. Approved by Underwriter's Labs. 20 minute flare is 11.5" and 30 minute flare is 15.5" in length. 70-80 candles bright. Available spikeless, with spike, and with wire. Sold by case quantity only.

| DESCRIPTION | PART # |
|---------------------------------|-------------------|
| 20 MIN. NON-SPIKE (CASE QTY 72) | 3006660 [0117944] |
| 20 MIN. SPIKE (CASE QTY 72) | 3006661 [0117956] |
| 20 MIN. WIRE (CASE QTY 72) | 3006659 [0117932] |
| 30 MIN. NON-SPIKE (CASE QTY 36) | 3001750 [0117279] |
| 30 MIN. SPIKE (CASE QTY 36) | 3004843 [0117267] |
| 30 MIN. WIRE (CASE QTY 36) | 3006658 [0117920] |

CYALUME LIGHT STICKS



Ideal for traffic control, utility operation and in-plant use. 7" length. 12-hour green, 30 minute hi-intensity red and 30 minute hi-intensity yellow. Just bend, snap and shake for instant light. Sold by standard pack of 10 only.

| DESCRIPTION | PART # |
|-------------------------|-------------------|
| 12 HOUR GREEN | 3015078 [2057655] |
| 30 MINUTE HI-INT RED | 3015077 [2056601] |
| 30 MINUTE HI-INT YELLOW | 3015076 [2056596] |

MINI-STROBE



Diameter: 4.6" at the base. Weight: 1.5 lb. Amp draw: 8. Micro-burst mini strobe. Sonic welded unit, completely sealed. Includes a 15" straight cord and cigarette lighter plug with a built in on/off switch. 3-year warranty, including the bulb. 60 bright quad flashes per minute. Blue, red and green lens can be special ordered. Call Customer Service for more information at 800-428-8185.

| DESCRIPTION | PART # |
|--|-------------------|
| 1.5 LB MINI STROBE, PLUGS INTO LIGHTER | 3008863 [2212279] |

ROTATING LIGHT



7-1/4"H x 4-3/4"W base diameter. Weight: 3.8 lbs. Amperage: 5 amps. Lens: polycarbonate. Candlepower: 12,000. Light Source: Quartz-Halogen Bulb. Electronics: All solid state circuitry. Operating Range: Outside temperature range between -50°F and 140°F. Stationary bulb has rotating reflector at 150 rpm. Rotating reflector is driven by a 12 volt D.C. motor. All units furnished with magnetic/suction pad base. Permanent mount light available.

| DESCRIPTION | PART # |
|---|-------------------|
| 3.8 LB ROTATING STROBE WITH MAGNETIC BASE, PLUGS INTO LIGHTER | 3007378 [2059419] |
| REPLACEMENT BULB | 3010136 |

LOW PROFILE STROBE



4-3/8"H x 4-1/4" base diameter. Weight: 2.5 lbs. Lens: Polycarbonate. Light Source: Single hit Xenon Flash Tube. Electronic: All solid state circuitry. Candlepower: 90,000. Amperage: 4 amps. Operating Range: Outside temperature range between -40°F to +122°F. Flash per minute: 60. Operating range of 11-15.5 volts. Offered only with magnetic/suction base design and cigarette lighter plug.

| DESCRIPTION | PART # |
|--|-------------------|
| 2.5 LB LOW PROFILE STROBE WITH MAGNETIC BASE, PLUGS INTO LIGHTER | 3008104 [2195380] |

SINGLE FLASH STROBE



4-1/2"H x 5-1/2" base diameter. Weight: 1.5 lbs. 18" cord. 12/24 V, multi-voltage. Rubber base for resistance to shock and vibration. Potted circuit to protect against dirt and moisture. Versatile and durable, featuring a low profile design. Bulb life: 1,000 hours. 2-year warranty (excluding bulb). Available in magnet mounted with coiled cord and cigarette plug. Blue, red and green lens can be special ordered.

| DESCRIPTION | PART # |
|--|-------------------|
| 1.5 LB SINGLE FLASH STROBE, PLUGS INTO LIGHTER | 3008862 [2212243] |

HEAVY DUTY STROBE



7-1/4"H x 4-3/4" base diameter. Weight: 3.8 lbs. Lens: Polycarbonate. Light Source: Double Xenon Flash Tube. Electronics: All solid state circuitry. Candlepower: 74,000. Amperage: 5 amps. Flash per minute: 60. Operating Range: Outside temperature range between -50°F and 140°F. Virtually maintenance-free. 10-30 volt range, warning light. All units furnished with magnetic/suction pad base or permanent mounting hardware.

DESCRIPTION

3.8 LB HD STROBE W/MAGNETIC BASE
3.8 LB HD STROBE PERMANENT MOUNT, ATTACHES TO BATTERY

PART #

3007306 [2057784]
3007307 [2057796]

SAFETY TRIANGLES



Shown left \$3006007 with 3 red triangles in case

Meets Federal Motor Vehicle Standard No. 125. Constructed on molded polypropylene plastic with red acrylic plastic reflectors. Air-flow design helps reduce wind resistance. Kit includes three triangles in one red, hard plastic case.

DESCRIPTION

HIGHWAY TRIANGLE - SINGLE
HIGHWAY TRIANGLE KIT - 3 TRIANGLES IN POLY BOX

PART #

3006010 [0100036]
3006007 [0100031]

FLEET EMERGENCY KIT



Kit contains: three compact safety triangles, one 2-3/4 lb. 10 B.C. fire extinguisher, three 30-minute color cyalume light sticks, one hold-down strap and heavy-duty red metal carrying case. Case size: 20"L x 7"W x 8"H.

DESCRIPTION

FLEET EMERGENCY KIT

PART #

3006009 [0100035]

MOTORIST SAFETY KIT



Kit contains: two 30-minute color cyalume light sticks, one compact highway warning triangle, one orange ESK reflective vest. All enclosed in a protective water-resistant bag.

DESCRIPTION

MOTORIST SAFETY KIT

PART #

3001747 [0109753]

SAFETY FENCING

Jackson Safety fences are produced with a material consisting of a UV stabilized high density polyethylene (HDPE) with a freezing point of approximately -112°F. For added convenience, every item is rolled, labeled, bagged, pelletized and stretch-wrapped. We offer fences for a variety of classifications: economy, mid-grade, diamond, speciality and erosion control silt fences.

GENERAL PURPOSE 12 LB. FENCE

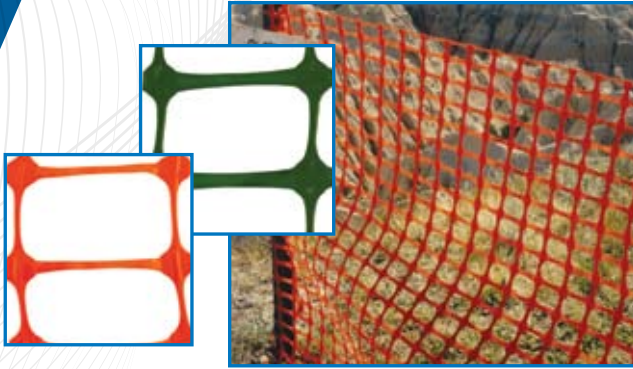

Mono-oriented safety fencing with horizontal openings. Size/Color: 4'x100', Orange; 4'x100' Green, Weight: 12 lbs. 48 rolls per pallet. Tensile Strength - MD: 240 lbs/ft, TD: 90 lbs/ft.

| DESCRIPTION | PART # |
|---------------|-------------------|
| ORANGE 12 LBS | 3007305 [2057679] |
| GREEN 12 LBS | 3007813 [2180153] |

LIGHT DUTY DIAMOND FENCE



Diamond mesh safety fence with smooth top and bottom. Size/Color: 4'x50' Orange, 4'x100' Green. Weight: 4'x50'/11 lbs; 4'x100'/23 lbs, 4'x50'/42 rolls per pallet; 4'x100'/20 rolls per pallet. Tensile Strength - MD: 100 lbs/ft, TD: 85 lbs/ft. Lower cost alternative to Mid Grade Diamond Fence

| DESCRIPTION | PART # |
|--------------------|---------|
| 4X50 ORANGE 11 LBS | 3014744 |
| 4X100 GREEN 23 LBS | 3014745 |

MID GRADE DIAMOND FENCE



Diamond mesh safety fence with smooth top and bottom. Size/Color: 4'x50' Orange, 5'x50' Orange. Weight: 4'x50'/14 lbs; 5'x50'/18 lbs 30 rolls per pallet. Tensile Strength - MD: 160 lbs/ft TD: 100 lbs/ft. Heavier and more visible than Light Duty Diamond Safety Fence

| DESCRIPTION | PART # |
|---------------------|-------------------|
| 4X50 ORANGE 14 LBS | 3007606 [2088353] |
| 4X100 ORANGE 23 LBS | 3006612 [0110283] |

HEAVY DUTY DIAMOND FENCE

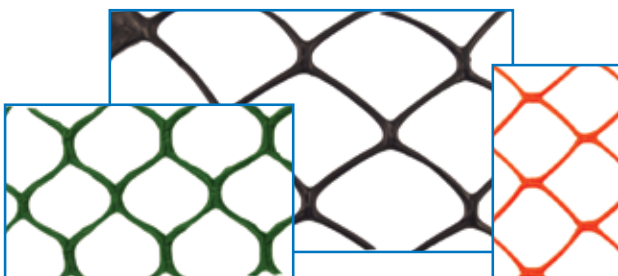

Diamond mesh safety fence with smooth top and bottom. Size/Color: 4'x50' Black; 4'x50' Green; 4'x50' Orange; 4'x100' Orange. Weight: 50'/16 lbs; 100'/32 lbs. 48 rolls per pallet. Tensile Strength - MD: 180 lbs/ft TD: 175 lbs/ft. Strongest and heaviest diamond mesh fence.

| DESCRIPTION | PART # |
|---------------|-------------------|
| BLACK 16 LBS | 3006609 [0110245] |
| GREEN 16 LBS | 3006610 [0110257] |
| ORANGE 16 LBS | 3011239 |
| ORANGE 32 LBS | 3006607 [0110221] |

ECONOMY FENCE



Lightweight safety fence with oval openings. Size/Color: 4'x100' Orange. Weight: 8.5 lbs. 48 rolls per pallet. Used as a visual barrier for crowd control and around job sites.

| | |
|--------------------|---------------|
| DESCRIPTION | PART # |
| ORANGE 8.5 LBS | 3014742 |

EROSION CONTROL SILT FENCE



100 ft woven silt fence with 42" hardwood stakes that are spaced 10' apart. Size/Color: 3x100 Black. Weight: 22.5 lbs. 25 rolls per pallet. Tensile Strength - MD: 20 lbs/ft TD: 20 lbs/ft.

| | |
|--------------------|-------------------|
| DESCRIPTION | PART # |
| BLACK 22.5 LBS | 3007594 [2087651] |

BARGARD® PROTECTOR CAPS

Low Density Polyethylene Material



CAL-OSHA

Fits rebar #3-7, 3/8" to 7/8" diameter. Lightweight and chemical resistant. Stands up to weather and temperature conditions. Bright orange for visibility. Standard package 100.

| | |
|---------------------------|---------------|
| DESCRIPTION | PART # |
| CAL-OSHA ORANGE REBAR CAP | 3011839 |



A-10

Fits rebar 3/8" to 1-1/4" diameter. Also fits inside 1-3/4" ID pipe. Standard Package: 100

| | |
|---------------------|-----------------|
| DESCRIPTION | PART # |
| A-10 LIME REBAR CAP | 3005543 [23700] |



A-5

Fits rebar 3/8" to 3/4" diameter. Also fits inside 1" ID pipe. Standard package 200.

| | |
|--------------------|-----------------|
| DESCRIPTION | PART # |
| A-5 LIME REBAR CAP | 3005547 [23704] |



A-20

Fits rebar 1" to 2-1/4" diameter. Standard package 100.

| | |
|----------------------|-----------------|
| DESCRIPTION | PART # |
| A-20 LIME REBAR CAP | 3005545 [23702] |
| A-20 WHITE REBAR CAP | 3005546 [23703] |

WARNING - BARGARD® caps are not designed or intended to provide impact or impalement protection. They are not a substitute for covering vertical reinforcing steel with timber, as recommended by OSHA, and are not recommended for use when protection from falls is required. For additional information on acceptable methods of guarding against impact or impalement, consult OSHA CFR TITLE 29, PART 19120, ANSI A10.9-1983, and your state regulations for specific requirements.

WARNING - DISC-10 BARGARD® PROTECTOR CAPS
DISC-10 meets the testing requirements of CAL OSHA Construction Safety Orders Section 1712 on impalement protection from concrete reinforcing bars (#3-9, 3/8 - 1-1/4") for heights up to 7-1/2" and 250 lbs. (CAL OSHA Approval Code #C-1716-AG) when properly installed. Failure to properly install DISC-10 will significantly decrease any impalement protection that may otherwise be provided by the DISC-10 and may result in injury. If positioning fins are missing or damaged, the DISC-10 must be discarded. For information on the requirements of guarding against impalement, consult OSHA CFR Title 29, Sect. 1928.701 et. seq.

For additional information on fall protection, consult OSHA CFR Title 29, Part 1926 - Safety and Health Regulations for Construction, Subpart M - Fall Protection and your state regulations for specific requirements.

Protect yourself from liability issues with the first name in slip, trip and fall protection. Lamba® products offer the original four-sided cone with a variety of messages and languages. Accessories include chain links and lock-in signs.

LAMBA® CONES



25" and 36" yellow and lime green models. Available plain or imprinted with stock legends. International languages and styles. 25" cone dimensions: 10" base, 4-3/4" middle, 3-1/4" top. 36" cone dimensions: 12" base, 6" middle, 3-1/2" top. Custom imprinting available. Standard

| DESCRIPTION | Pack: 5 | PART # | DESCRIPTION | PART # |
|--|---------|-----------------|--|-----------------|
| 25" YELLOW FLOOR CONES | | | 36" YELLOW FLOOR CONES | |
| PLAIN | | 3000479 [23820] | PLAIN | 3000485 [23888] |
| CAUTION | | 3005557 [23819] | CAUTION | 3000484 [23887] |
| NO PARKING | | 3010288 [23801] | DANGER PEOPLE WORKING ABOVE | 3005563 [23834] |
| SAFETY FIRST | | 3000478 [23809] | FLOOR MAY BE SLIPPERY | 3005564 [23836] |
| WET FLOOR | | 3005553 [23812] | HAZARDOUS MATERIAL | 3009773 [23911] |
| CUIDADO PISO MOJADO | | 3005584 [23935] | ICY AREAS | 3005591 [23983] |
| CUIDADO PISO MOJADO/WET FLOOR | | 3005555 [23816] | NO ENTRY - RESTROOM CLOSED | 3005565 [23838] |
| CUIDADO/SEGURIDAD AUTE TODO/SAFETY FIRST | | 3005552 [23811] | NO PARKING | 3005566 [23839] |
| CUIDADO/WET FLOOR | | 3005556 [23817] | RESTRICTED AREA | 3005571 [23861] |
| PLANCHER MOUILLE/WET FLOOR | | 3005554 [23815] | SAFETY FIRST | 3000481 [23863] |
| | | | WET FLOOR | 3000482 [23870] |
| | | | DRIVE UP SERVICE | 3019461 |
| | | | CUIDADO PISO MOJADO/WET FLOOR | 3000483 [23879] |
| | | | CUIDADO/SEGURIDAD AUTE TODO/SAFETY FIRST | 3005575 [23868] |
| | | | 36" LIME FLOOR CONES | |
| | | | WET FLOOR | 3005661 [24238] |

CONE SYSTEMS

THREE CONE SYSTEM

25" or 36" cone systems include: 3 yellow cones, 1 red flashing lights, 1-20' yellow plastic chain, 2 lock-in signs (red) and 4 message labels. International system available only in 36".



FIVE CONE SYSTEM

25" or 36" cone systems include 5 yellow cones, 3 red flashing lights, 2-20' yellow plastic chains, 2 lock-in signs (red) and 4 message labels.



| DESCRIPTION | PART # |
|---------------------------------|-----------------|
| 25" WET FLOOR | 3005558 [23824] |
| 36" WET FLOOR | 3005579 [23891] |
| 36" SAFETY FIRST | 3005578 [23890] |
| 36" WET FLOOR (ENGLISH/SPANISH) | 3005590 [23980] |

| DESCRIPTION | PART # |
|---------------------------------|-----------------|
| 25" WET FLOOR | 3005559 [23826] |
| 36" WET FLOOR | 3005581 [23893] |
| 36" SAFETY FIRST | 3005580 [23892] |
| 36" WET FLOOR (ENGLISH/SPANISH) | 3005586 [23946] |

2" YELLOW PLASTIC CHAIN



Helps to expand the effectiveness of the Lamba cones or 2x4™. Attach either slide link into the side of Lamba cone or to the custom hooks on our 2x4™ to create a safety system.

| DESCRIPTION | PART # |
|-------------|-----------------|
| 20' CHAIN | 3000539 [26407] |
| 100' CHAIN | 3000540 [26408] |

LAMBA CUSTOMIZATION PROGRAM

Company recognition as well as safety messages can be conveyed with customized cones, floor warning signs and message labels.

LAMBA CONES

- Minimum order = 75 cones per imprint size (may not combine 25" and 36" cones); No silk-screening charge on orders exceeding 200 cones
- Images can be one color, silk-screened as follows: Same message on all four sides; 2 different messages on two sides

2X4 FLOOR WARNING SIGNS

- Minimum order = 30 floor warning signs; 12 labels per message
- Logo imprint area measures 2" H x 4" W; Image is silk-screened on both sides of 2x4

PLEASE NOTE: Jackson Safety requires camera-ready artwork. Minimum of 3 week lead-time after approval of artwork. Definition of camera ready/photo reproducible artwork is black on glossy white background with sharp images (photocopies, business cards, drawings, letterhead and decals are not camera-ready and require additional charges). Screen printing only available in black ink. One time silk-screen charge per screen applies.

LAMBA CONE ACCESSORIES



RING WEIGHTS

Black metal. Slides over cone and rests on base.
Weight for 25" cones inner dimensions: 8" x 8"
Weight for 36" cones inner dimensions: 10" x 10"

| DESCRIPTION | PART # |
|------------------------|-----------------|
| 25" CONE WEIGHT 7 LBS | 3005687 [26413] |
| 36" CONE WEIGHT 9 LBS. | 3000541 [26414] |



LOCK-IN SIGNS

8" x 8" plastic sign that can be placed in top of Lamba cones to display message labels.

| DESCRIPTION | PART # |
|-------------|-----------------|
| BLACK SIGN | 3000537 [26400] |
| RED SIGN | 3000538 [26401] |



LOCK-IN FLASHING LIGHTS

Flashing light has convenient on/off switch and lasts up to 300 hours. Requires 2 AA batteries (not included).

| DESCRIPTION | PART # |
|------------------------|-----------------|
| LOCK-IN FLASHING LIGHT | 3000549 [26649] |

MESSAGE LABELS

Yellow 8" x 8" adhesive backed vinyl for use on our lock-in signs.



| DESCRIPTION | PART # | DESCRIPTION | PART # |
|----------------------------|-----------------|------------------------------------|-----------------|
| ENGLISH | | ENGLISH | |
| PLAIN (NO VERBAGE) | 3005709 [26483] | WET FLOOR PLEASE WALK TO THE RIGHT | 3000544 [26490] |
| SECTION CLOSED | 3005694 [26449] | WET FLOOR PLEASE WALK TO THE LEFT | 3000545 [26491] |
| SLIPPERY | 3005699 [26469] | CAUTION FLOOR MAY BE SLIPPERY | 3005718 [26501] |
| OUT OF SERVICE | 3005702 [26473] | CAUTION - WET FLOOR | 3005719 [26502] |
| ELECTRICAL HAZARD | 3005704 [26475] | DANGER PEOPLE WORKING ABOVE | 3005721 [26505] |
| HARD HAT AREA | 3005705 [26477] | BLACK ARROW | 3005713 [26489] |
| NO ENTRY - CONSTRUCTION | 3005706 [26478] | CAUTION - FALLING ICE | 3005730 [26559] |
| WATCH YOUR STEP | 3005708 [26480] | INTERNATIONAL | |
| RESTROOM CLOSED - NO ENTRY | 3000543 [26481] | WET FLOOR (ENGLISH/SPANISH) | 3000546 [26498] |
| PEOPLE WORKING | 3005710 [26485] | OUT OF SERVICE (ENGLISH/SPANISH) | 3005726 [26536] |
| NO ENTRY - RESTRICTED AREA | 3005711 [26487] | WATCH YOUR STEP (ENGLISH/SPANISH) | 3005727 [26539] |

2X4 SAFETY FLOOR SIGNS



The Lamba® 2x4 safety floor sign helps corporations control the environment and dramatically reduce liability programs. Featuring our Lockin'Arm™ technology for easy set-up and extra stability. Four-sided caution messages display clear warnings from every angle. The 25" high, bright yellow plastic signs fold up quickly and store in spaces as narrow as 3". Standard Pack: 5

| DESCRIPTION - ALL YELLOW UNLESS OTHERWISE INDICATED | PART # |
|---|-----------------|
| YELLOW, PLAIN | 3005622 |
| CAUTION, WET FLOOR | 3000488 [24102] |
| SAFETY MAN, LARGE, WET FLOOR | 3005605 [24103] |
| WET FLOOR, WALK RIGHT/LEFT | 3005606 [24105] |
| WET FLOOR, CUIDADA PISO MOJADO (LIME) | 3000489 [24106] |
| NO ENTRY, RESTROOM CLOSED | 3005609 [24109] |
| CAUTION, WATCH YOUR STEP | 3005610 [24110] |
| CAUTION WET FLOOR/CUIDADO PISO MOJADO (LIME) | 3005825 [26815] |

ECONOMY FLOOR STANDS



Lightweight, corrosion resistant and moisture proof. Wide, 'easy-grip' handle ensures easier transportation. Larger printing area provides greater visibility for your message. Folds flat for easy storage. Standard legends only. 11-3/4" W x 24-1/8" H (open).

| DESCRIPTION | PART # |
|---------------------------------------|-------------------|
| YELLOW, PLAIN | 3017717 [3005898] |
| CAUTION WATCH YOUR STEP | 3017718 [3005899] |
| CAUTION WET FLOOR/CUIDADO PISO MOJADO | 3017719 [3005900] |
| CLOSED/CERRADO FERMÉ | 3017720 [3005901] |
| NO ENTRY RESTROOM CLOSED | 3017721 [3005902] |
| OUT OF SERVICE | 3017722 [3005903] |
| CAUTION WET FLOOR | 3017723 [3000585] |



WWW.JACKSONSAFETY.COM
1859 BOWLES AVENUE, SUITE 200 FENTON, MO 63026

TRAFFIC SAFETY

PHONE: 800.428.8185 FAX: 800.634.9517

INTERNATIONAL

PHONE: 636.349.1193 FAX: 636.349.9582

WELDING SAFETY

PHONE: 800.253.7281 FAX: 800.338.4003