

12/18/2012

Adjustable Optics LED Emergency Light

Features

- Compact, low-profile design
- Universal mounting plate with EZ Quick Connect for fast installation
- UL listed for damp locations & meets UL924, NFPA 101 Life Safety Code, NEC, OSHA, Local and State Codes

Electrical

- Dual 120V/277V voltage
- Charge rate/power "ON" LED indicator light and push-to-test switch for mandated code compliance testing
- 3.6V, maintenance-free, rechargeable NiCd battery
- Internal solid-state transfer switch automatically connects the internal battery to lamp heads for minimum 90-minute emergency illumination
- Fully automatic solid-state, two-rate charger initiates battery charging to recharge a discharged battery in 24 hours

Volts	Wattage	Current
120V	2.1W	0.025A
277V	2.1W	0.010A

Illumination

- Long-life, ultra bright white LED lamp heads
- 1 watt (8 LEDs x 0.125 watt) per head
- High performance, chrome plated metalized reflector and plastic lens for optimal light distribution
- Two fixed or adjustable LED lamp heads provide optimal center-to-center spacing

Housing

- Injection-molded, engineering-grade, 5VA flame retardant, high-impact resistant, thermoplastic in white or black finish

ORDERING INFORMATION

Model Family #	Housing Color
HL0223L	W - White B - Black
example model# HL0223LW	

Specifications subject to change without notice.

Project:	
Catalog#:	
Approved by:	



Mounting

- Surface mount via easy connect back plate, which fits most standard junction boxes and snaps into place making internal electrical connections.
- Suitable for wall or ceiling mount

Dimensions

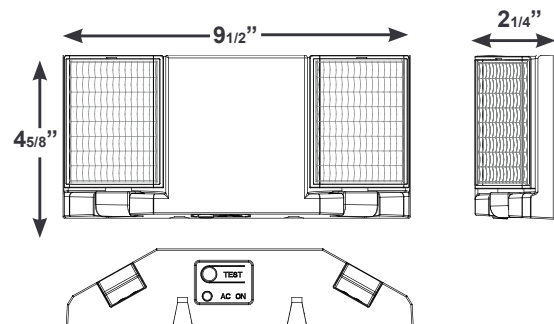

Emergency Light