

**OPERATOR'S MANUAL
AND PARTS LIST
MODEL GRTCH350/GRTRH350
FRAMING NAILERS**

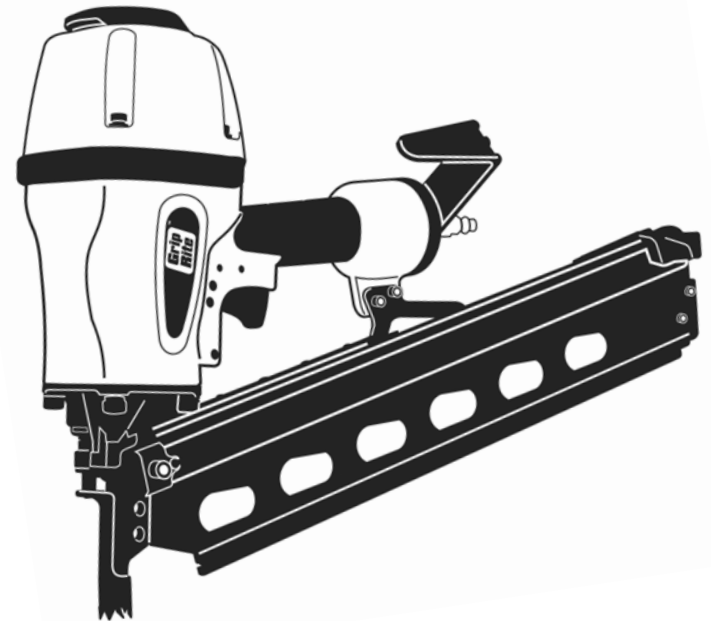

Distributed by/Distribuido por/Imported by/Importé par:

PRIMESOURCE[®]
BUILDING PRODUCTS, INC.

and
BUILDING PRODUCTS CANADA CORPORATION
are Itochu Companies

Carrollton, Texas 75006 USA
www.grip-rite.com



IMPORTANT SAFETY INFORMATION

You must read this entire manual and familiarize yourself with all safety, operating, and service instructions before loading, handling, or using your tool. When used correctly, pneumatic fastening tools provide a lightweight, powerful, and safe means of fastening. Used improperly, these tools can cause serious injury to you and those around you.

TABLE OF CONTENTS ----- 3

GRTCH350 SPECIFICATIONS ----- 4

GRTCH350 Fastener Selection Chart ----- 4

GRTRH350 SPECIFICATIONS ----- 5

GRTRH350 Fastener Selection Chart ----- 5

SAFETY ----- 6

TOOL PARTS ----- 10

PART DESCRIPTIONS ----- 11

OPERATION ----- 12

Loading Fasteners ----- 12

Air Deflector Adjustment ----- 12

Adjusting Nail Drive ----- 13

No-Mar Pad Installation ----- 13

TOOL OPERATION ----- 14

Sequential Operation ----- 14

Contact Trip Operation ----- 14

MAINTENANCE ----- 15

Lubrication ----- 15

Cleaning ----- 15

Trigger Check ----- 15

GRTCH350 PARTS SCHEMATIC ----- 16

GRTCH350 PARTS LIST ----- 17

GRTRH350 PARTS SCHEMATIC ----- 18

GRTRH350 PARTS LIST ----- 19

TROUBLESHOOTING ----- 20

TOOL CHECKS ----- 21

WARRANTY ----- 22

GRTCH350 SPECIFICATIONS

SPECIFICATIONS

MODEL	GRTCH350 FRAMING NAILER
FASTENER RANGE	2" - 3 1/2" (50 mm - 90 mm)
FASTENER TYPE	.113 - .148 dia. (3 - 3.8 mm) Clipped Head
MAGAZINE CAPACITY	75 Nails - 33° Clipped Head Paper Tape
MAX AIR PRESSURE	120 PSI (8.3 bar) psi
MIN AIR PRESSURE	70 (4.8 bar) psi
TOOL WEIGHT	7.81 lbs. (3.5 kg)
TOOL LENGTH	18 1/2" (47 cm)
TOOL HEIGHT	14 3/4" (37.5 cm)
TOOL WIDTH	7 5/16" (18.7 cm)
TRIGGER TYPE	SEQUENTIAL (DUAL ACTION KIT INCLUDED)
AIR INLET	3/8 NPT
AIR CONNECTION	MALE QUICK CONNECT COUPLER
LUBRICATION	10W Air Tool Oil (Provided)

NOISE CHARACTERISTIC VALUES IN ACCORDANCE WITH ISO 3774, ISO 11201:

A-weighted single-event sound pressure level at operator's position -----	LpA, 1s = 93 dBA
A-weighted single-event sound power level -----	LwA, 1s = 102 dBA
A-weighted single-event surface sound pressure level -----	LpA, 1s = 89 dBA

VIBRATION CHARACTERISTIC VALUES IN ACCORDANCE WITH ISO 8862-1

Weighted root mean square acceleration ----- = **3.6 m/s²**

For best results, use only Grip-Rite™ collated fasteners.

GRTCH350 FASTENER SELECTION CHART						
Size	Box	Shank	Bright	Galvanized	HD Galvanized	
6D 2"x .113	2.5M	Smooth	GRSP6D	GRSP6DG	N/A	
6D 2"x .113	2.5M	Ring	GRSP6DR	GRSP6DRG	GRSP6DRHG	
8D 2-3/8"x .113	2.5M	Smooth	GRSP8D	GRSP8DG	GRSP8DRHG	
8D 2-3/8"x .113	2.5M	Ring	GRSP8DR	GRSP8DRG	GRSP8DRHG	
10D 3"x .120	2M	Smooth	GRSP10D	GRSP10DG	GRSP10DRHG	
10D 3" x .120	2M	Ring	N/A	GRSP10DRG	GRSP10DRHG	
10D 3" x .131	2M	Smooth	GRSP10DZ	GRSP10DZG	N/A	
12D 3-1/4" x .120	2M	Ring	N/A	GRSP12DRG	GRSP12DRHG	
12D 3-1/4" x .131	2M	Smooth	GRSP12DZ	GRSP12DZG	GRSP12DZHG	
16D 3-1/2" x .131	2M	Smooth	GRSP16DZ	GRSP16DZG	GRSP16DZHG	

GRTRH350 SPECIFICATIONS

SPECIFICATIONS

MODEL	GRTRH350 FRAMING NAILER
FASTENER RANGE	2" - 3 1/2" (50 mm - 90 mm)
FASTENER TYPE	.113 - .148 dia. (3 - 3.8 mm) Round Head
MAGAZINE CAPACITY	65 Nails - 21° Plastic Collation
MAX AIR PRESSURE	120 PSI (8.3 bar) psi
MIN AIR PRESSURE	70 (4.8 bar) psi
TOOL WEIGHT	7.9 lbs. (3.6 kg)
TOOL LENGTH	21 1/4" (54 cm)
TOOL HEIGHT	14 3/4" (37.5 cm)
TOOL WIDTH	6 7/16" (16.4 cm)
TRIGGER TYPE	SEQUENTIAL (DUAL ACTION KIT INCLUDED)
AIR INLET	3/8 NPT
AIR CONNECTION	MALE QUICK CONNECT COUPLER
LUBRICATION	10W Air Tool Oil (Provided)

NOISE CHARACTERISTIC VALUES IN ACCORDANCE WITH ISO 3774, ISO 11201:

A-weighted single-event sound pressure level at operator's position -----	LpA, 1s = 91 dBA
A-weighted single-event sound power level -----	LwA, 1s = 101 dBA
A-weighted single-event surface sound pressure level -----	LpA, 1s = 88 dBA

VIBRATION CHARACTERISTIC VALUES IN ACCORDANCE WITH ISO 8862-1

Weighted root mean square acceleration ----- = **4.2 m/s²**

For best results, use only Grip-Rite™ collated fasteners.

GRTRH350 FASTENER SELECTION CHART						
Size	Box	Shank	Bright	Galvanized	HD Galvanized	
6D 2"x .113	2.5M	Smooth	GR03L	GR05GL	N/A	
6D 2"x .113	2.5M	Ring	GR04L	N/A	N/A	
8D 2-3/8"x .113	2.5M	Smooth	N/A	GR09GL	GR09HGL	
8D 2-3/8"x .113	2.5M	Ring	GR08RL	GR08GL	GR08HGL	
10D 3"x .120	2M	Smooth	GR301L	GR301GL	GR301HGL	
10D 3" x .120	2M	Ring	N/A	GR408GL	GR408HGL	
10D 3" x .131	2M	Smooth	GR014L	N/A	N/A	
12D 3-1/4" x .120	2M	Smooth	GR444L	GR444GL	GR444HGL	
16D 3-1/4" x .131	2M	Smooth	GR024L	GR034GL	GR034HGL	
16D 3-1/2" x .131	2M	Smooth	GR312131L	N/A	N/A	

SAFETY LABELS

This pneumatic fastening tool includes a warning label to help remind you of important safety information when operating the tool. The safety label must be legible at all times, and must be replaced if it becomes worn or damaged.

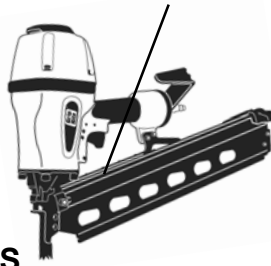
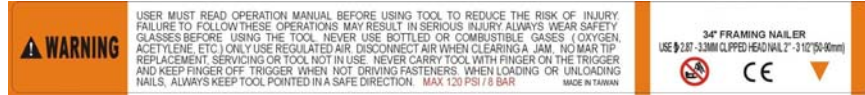

SAFETY SYMBOLS

These safety symbols provide a visual reminder of basic safety rules, and the personal injury hazard that may arise if all safety and operating instructions are not followed. Make sure you understand the meaning of each of these symbols, and protect yourself and others by obeying all safety and operating instructions.

SYMBOL	DESCRIPTION
	READ THE MANUAL - The manual contains important safety and operating instructions that must be followed. All tool users must read the manual before using the tool.
	WEAR SAFETY GLASSES - Tool operator and bystanders must wear safety glasses with side shield that meet ANSI Z87.1 requirements.
	RISK OF PERSONAL INJURY - Failure to follow all safety and operating instructions, or misuse of the tool, can result in serious injury to tool operator and bystanders.

SAFETY INSTRUCTIONS



WEAR SAFETY GLASSES

Always wear safety glasses with side shields that meet ANSI Z87.1 requirements when operating the tool. Make sure all others in work area wear safety glasses.



WEAR HEARING PROTECTION

Wear hearing protection to protect your hearing from noise. Prolonged exposure to loud noise can result in hearing loss.



NEVER OPERATE THE TOOL WITH OXYGEN OR OTHER BOTTLED GASES

Oxygen and other reactive or high-pressure bottled gases can cause the tool to explode. Use clean, dry regulated compressed air from a properly operating air compressor.

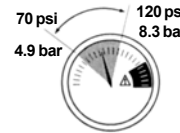

DO NOT EXCEED MAXIMUM RECOMMENDED OPERATING AIR PRESSURE OF 120 PSI / 8.6 Bar.

Exceeding the maximum recommended air pressure can cause the tool housing to burst, or cause premature failure of components.



NEVER CONNECT THE TOOL TO AN AIR SUPPLY THAT HAS THE POTENTIAL TO EXCEED 180 PSI/12.4 Bar.

Using a regulated air supply with a line or tank pressure greater than 180 psi can cause the tool to burst if the air line regulator fails suddenly.

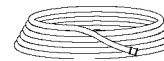

USE AN AIR HOSE RATED FOR 180 PSI/12.4 Bar OR GREATER

Always use air hose rated to handle 180 psi or the maximum potential pressure of the air supply.

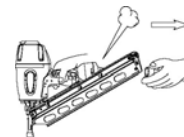

ONLY USE A RELIEVING-TYPE AIR COUPLING IN THE TOOL AIR INLET OPENING.

Use of a non-relieving air coupling on the tool can trap air inside the tool housing, and allow the tool to drive a fastener even after the air hose has been disconnected.

SAFETY INSTRUCTIONS

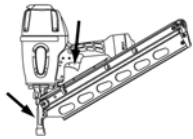

DO NOT ATTEMPT TO OPERATE THE TOOL IF THE TOOL'S OPERATING CONTROLS HAVE BEEN MODIFIED OR ARE NOT WORKING PROPERLY.

Attempting to use a tool with modified or malfunctioning trigger or workpiece contact can result in a fastener being driven unintentionally.

USE CORRECT FASTENERS

Only use the correct fastener for the tool. Using fasteners with incorrect specifications can jam the tool or cause serious injuries.

USE THE CORRECT FASTENERS FOR THE APPLICATION.

Using the wrong fasteners can cause the workpiece to split and allow the fastener to fly free.

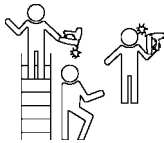

KEEP TOOL POINTED IN A SAFE DIRECTION WHEN LOADING FASTENERS.

Never point the tool at yourself or anyone else when loading fasteners.

DO NOT LOAD TOOL WITH TRIGGER OR WORKPIECE CONTACT DEPRESSED.

Depressing the trigger or workpiece contact during loading can result in an unintentional fastener drive if both devices are accidentally actuated at the same time.

KEEP FINGER OFF TRIGGER UNTIL TOOL IS IN POSITION TO DRIVE A FASTENER.

An unexpected bump or sudden contact with your body or that of a bystander can result in serious injuries.

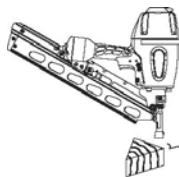

AVOID DRIVING FASTENERS INTO KNOTS, ON TOP OF OTHER FASTENERS, AT WORKPIECE EDGES, OR INTO BRITTLE MATERIALS.

Driving fasteners into extremely hard materials, or driving into workpiece edges, can cause fasteners to deflect away from the workpiece. Flying fasteners can cause serious injuries.

SAFETY INSTRUCTIONS

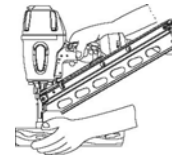

KEEP HANDS AND BODY PARTS AWAY FROM AREA BEING FASTENED.

Fasteners can deflect and turn as they are being driven into the workpiece, and penetrate fingers, hands, and other body parts that may be in the fastening area.



DO NOT OVERREACH OR WORK WHILE ON UNSTABLE FOOTING

If you lose your balance while fastening, you could drive a fastener into yourself or a bystander.

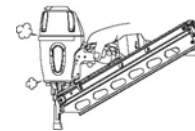

DO NOT USE TOOL IF TOOL MALFUNCTIONS OR BEGINS LEAKING AIR.

Operating a malfunctioning tool can result in an unexpected fastener discharge and injury to yourself or others.

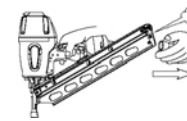

DISCONNECT THE TOOL FROM THE AIR SUPPLY TO RELOAD, CLEAR JAMS, OR PERFORM MAINTENANCE.

Never attempt to reload a tool, clear a jam, or perform maintenance without first disconnecting the air supply.

NEVER LEAVE A LOADED, PRESSURIZED TOOL UNATTENDED

A loaded, pressurized tool could be picked up or handled by someone who is unfamiliar with the tool or that has not read the tool manual.

KEEP TOOLS OUT OF THE REACH OF CHILDREN

Place the tool back in the tool box after use, and store the tool out of reach.

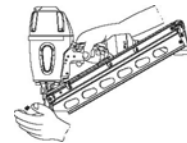

DO NOT MODIFY TOOL

Modifications can cause a tool to be unsafe and can cause the tool to operate improperly.

DESCRIPTION

TOOL PARTS

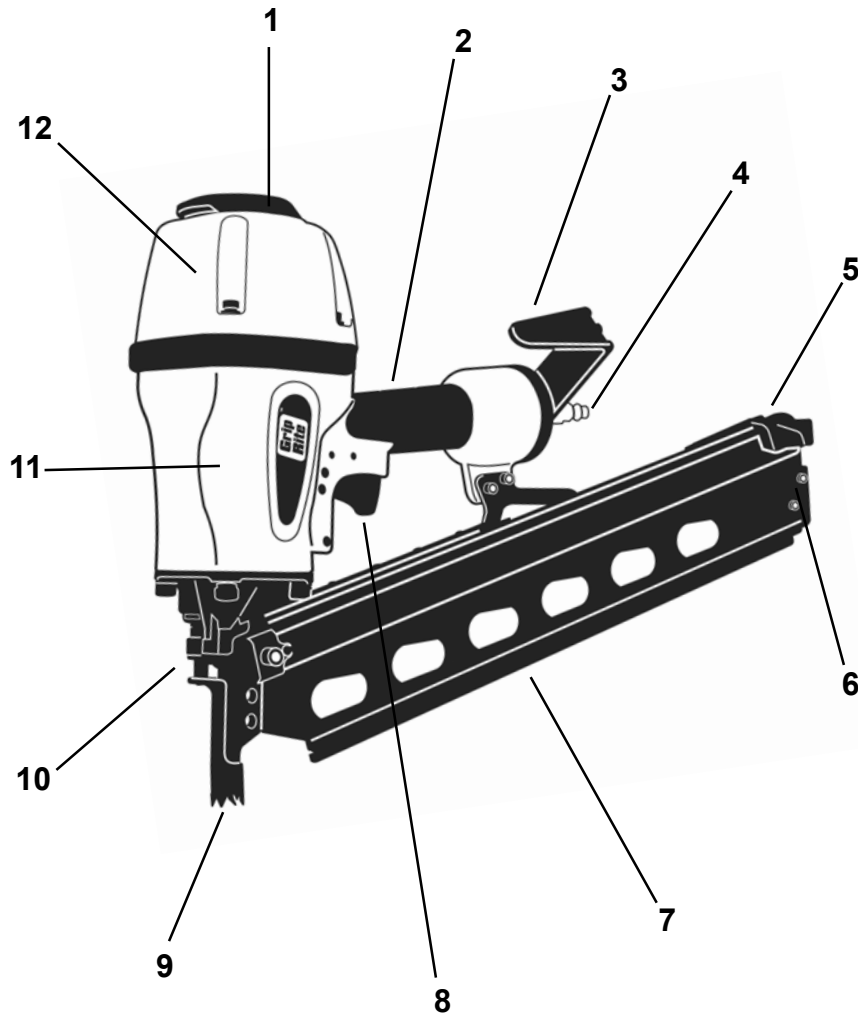

DESCRIPTION

PART DESCRIPTIONS

1. **360° Adjustable Air Deflector** - Tool-free adjustment blows exhaust air away from operator. 12 locking positions for secure settings.
2. **Cushioned Grip** - Cushioned handgrip reduces fatigue and provides comfortable operation.
3. **Rotating Belt Hook** - Durable tool hook slides on belt. Holds tool securely and keeps it in reach for greater productivity.
4. **Air Coupling** - Quick-disconnect male coupling allows quick connection to air hose. Dust cap keeps dirt out when tool is not in use.
5. **Spring-loaded Pusher** - Provides positive fastener feeding in all tool positions. Latches in open position for rapid, one-handed loading. Last-nail lockout prevents blank firing.
6. **Pusher Release Lever** - Holds pusher for loading, releases pusher for feeding nails.
7. **Fastener Magazine** - Lightweight fastener magazine reduces tool weight, allows quick check of nail size and quantity.
8. **Sequential Trigger** - Actuates tool only when correct trigger operating sequence is followed. Does not allow bump firing.
9. **No-Mar Pad** - Removeable pad prevents marring of work. Conveniently stores on tool when not needed.
10. **Adjustable Depth of Drive** - Tool-free depth of drive adjustment allows nail drive adjustments to be made at tool for consistent depth control.
11. **Magnesium Tool Housing** - Light weight, durable magnesium tool housing reduces tool weight, reduces operator fatigue.
12. **Heavy Duty Cap** - Seals tool housing.

Dual Action Trigger Kit - Permits contact-trip (bump fire) or trigger-fire operation. (Single fire sequential trigger standard)

Metric Hex Wrenches - Included with tool to allow tightening of metric screws. Keep tools in tool case for periodic tightening of screws.

Air Tool Oil - Lightweight oil formulated for use in air tools provides proper lubrication to o-rings and internal parts.

Safety Goggles - Provide required eye protection

LOADING FASTENERS

LOADING INSTRUCTIONS

DANGER

A fastener can be driven unintentionally if the trigger and safety bracket are activated at the same time. Always disconnect tool from air supply before loading fasteners, making adjustments, or performing any service on tool. Keep finger off trigger until ready to drive a fastener.

1. Hold tool handgrip securely, and pull pusher (A) back until it locks in latched position at rear of magazine (B).
2. Insert nail strip (C) into magazine, with nail points angled forward and down.
3. Pull pusher back, press release lever (D), and slide pusher forward against nails.
4. Tool is now loaded and ready for normal operation.

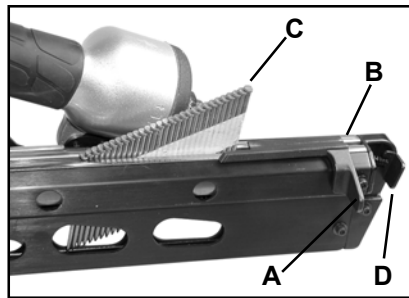

AIR DEFLECTOR ADJUSTMENT

1. If necessary, the air deflector (E) may be rotated to direct exhaust air discharge away from operator.
2. Grip air deflector, and rotate until discharge port is pointed in the desired direction.
3. Check deflector position periodically to make sure exhaust air discharge is directed in a safe direction.

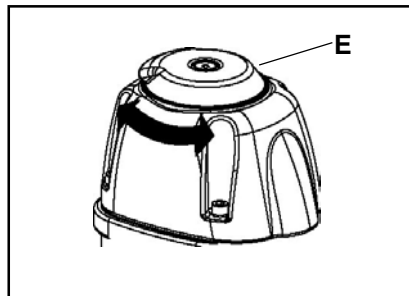

ADJUSTING NAIL DRIVE

1. Disconnect tool from air supply using quick-connect coupling.
2. Turn adjustment dial (F) backward toward magazine to increase nail drive, or forward toward front of tool to decrease nail drive, as shown by nail symbols on tool.
3. Connect tool to air supply, and drive nails to check for correct depth of drive.
4. Make depth of drive adjustments as needed to maintain consistent nail driving.

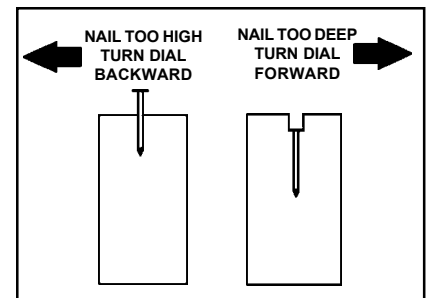
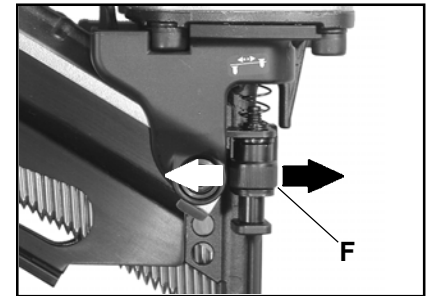

NO-MAR PAD

1. Disconnect tool from air supply using quick-connect coupling.
2. Remove no-mar pad from hanger on nail magazine.
3. Align slot in pad with slot in safety bracket, and slide no-mar pad over tip of safety bracket. Make sure pad is fully seated on safety bracket.
4. Remove no-mar pad from safety bracket when not needed, and store on tool using pad storage bracket.

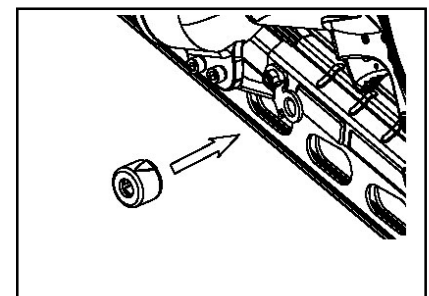
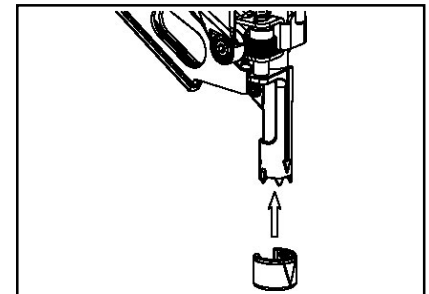

TOOL OPERATION

SEQUENTIAL OPERATION

1. Hold the tool securely using the handgrip. Keep finger off trigger until tool is in position and you are ready to drive a fastener. NOTE: Depressing trigger before depressing safety bracket will prevent tool from actuating.
2. Position the nose of the tool on the workpiece, placing the nose at the desired fastener driving position.
3. Press the tool down firmly against the work surface, fully depressing the workpiece contact (safety bracket).
4. Squeeze the trigger once to drive a fastener.
5. Allow the tool to rebound off the work surface, and release the trigger to reset the workpiece contact. Tool will not drive another fastener until trigger is released, and cannot be bump-fired with sequential trigger installed.
6. Check fastener for flush drive, and if needed, turn nail depth adjustment dial to obtain desired fastener drive.
7. If tool adjustments do not provide the desired results, make air pressure adjustments at the compressor: Increase air pressure to drive deeper or to drive into harder materials. Reduce air pressure to reduce drive or to drive into softer materials. For longest tool and part life, always use the lowest air pressure necessary to drive fasteners to desired depth.
8. Position the tool for driving the next fastener, and repeat the above procedure. Always keep hands and other body parts away from areas being fastened.

CONTACT TRIP (BUMP FIRE) DRIVING METHOD

To operate this tool in contact trip mode (bump-firing), remove the sequential trigger provided on the tool, and install the dual-action trigger provided with the tool.

1. Position the nose of the tool over the work surface, near the area where the first fastener is to be driven.
2. Squeeze and hold the trigger in the depressed position.
3. Bump the workpiece contact (safety) against the work surface at each point where a fastener is to be driven.
4. Using a bouncing motion, continue moving the tool into position for each fastener drive.
5. When fastening is completed, release the trigger.

MAINTENANCE

Your tool will last longer and perform better if periodic maintenance is performed. Please use the information below to keep your tool operating in top condition.

Lubrication

Disconnect tool from the air supply and remove all fasteners. Apply 3 - 5 drops of air tool oil (provided) in the air inlet two - three times a day. If the tool will be used outside in the winter, use a winter grade air tool oil to help keep frost from forming inside the tool. Do not use other types of lubricants on this tool, as other lubricants may contain chemicals harmful to o-rings and other tool components. Drain compressor tanks and hoses daily.

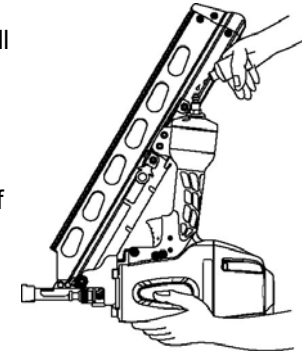

Cleaning

Disconnect tool from the air supply and remove all fasteners. Brush tool off using a parts cleaning brush or clean rag. Check area around trigger and workpiece contact, and clean as necessary.

Trigger Check

Check trigger operation daily to confirm proper sequential operation:

1. Press the workpiece contact against a safe work surface without depressing the trigger. **THE TOOL MUST NOT CYCLE.**
2. Hold the tool above a safe work surface and pull the trigger without depressing the workpiece contact. **THE TOOL MUST NOT CYCLE.**
3. Pull and hold the trigger, and then press the workpiece contact against a safe work surface. **THE TOOL MUST NOT CYCLE.**
4. With finger off trigger, press the workpiece contact against a safe work surface. Keep tool pressed against work surface, and pull trigger. **THE TOOL MUST CYCLE ONCE.**
5. The trigger must return to the normal position each time finger pressure is released.

GRTCH350 PARTS SCHEMATIC

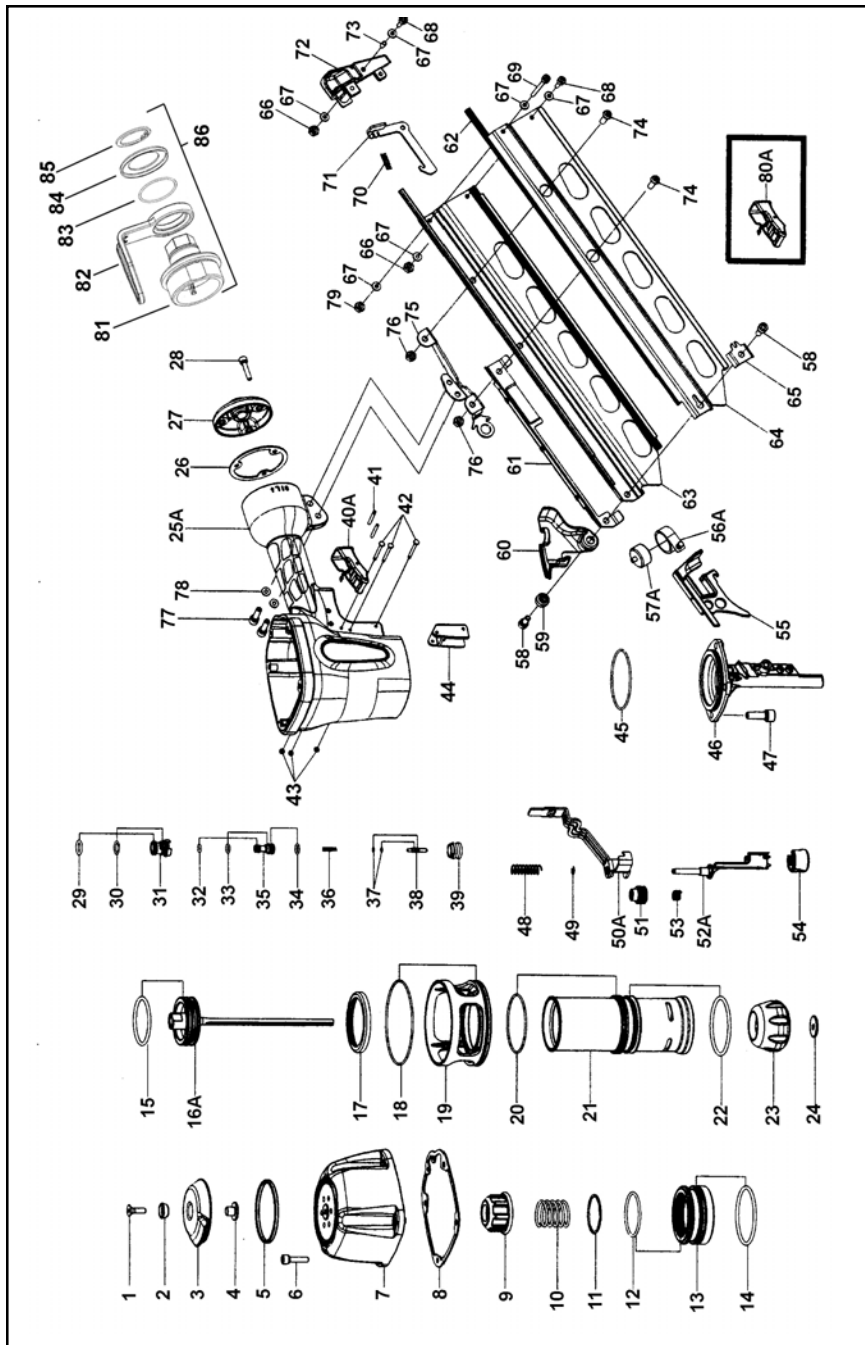

GRTCH350 PARTS LIST

ITEM	P/N	DESCRIPTION	ITEM	P/N	DESCRIPTION
1	GRTN2050	Hex.Soc.Hd.Bolt	44	GRTN370	Guide,Safety Lever
2	GRTN230	Washer	45	GRTN2440	O-Ring
3	GRTN170	Deflector	46	GRTN320	Nose
4	GRTN160	Washer	47	GRTN2010	Hex.Soc.Hd.Bolt
5	GRTN2410	O-Ring	48	GRTN350	Spring,Safety
6	GRTN2000	Hex.Soc.Hd.Bolt	49	GRTN2670	E-ring
7	GRTN2900	Cap	50A	GRTN340	Upper Safety Lever Assy.
8	GRTN180	Gasket	51	GRTN400	Adjusting Nut
9	GRTN190	Piston Stopper	52A	GRTN360	Lower Safety Lever Assy.
10	GRTN210	Spring	53	GRTN410	Adjusting Spring
11	GRTN220	Washer	54	GRTN390	Rubber Pad
12	GRTN2160	O-Ring	55	GRTN480	Pusher
13	GRTN200	Piston,Head Valve	56A	GRTN460	Spiral Spring Assembly
14	GRTN2420	O-Ring	57A	GRTN470	Roller Pin Assembly
15	GRTN2200	O-Ring	58	GRTN1960	Hex.Soc.Hd.Bolt
16A	GRTN270	Driver Assembly	59	GRTN330	Nose Cap Bushing
17	GRTN240	Seal	60	GRTN380	Safety Cap
18	GRTN2460	O-Ring	61	GRTN540	Magazine Cover
19	GRTN250	Cylinder Hold Down	62	GRTN440	Nail Guide Liner
20	GRTN2430	O-Ring	63	GRTN430	Magazine-Lower
21	GRTN260	Cylinder	64	GRTN510	Magazine-Upper
22	GRTN2190	O-Ring	65	GRTN420	Bracket
23	GRTN280	Bumper	66	GRTN2060	Locknut
24	GRTN290	Driver Guide	67	GRTN2620	Flat Washer
25A	GRTN2910	Body Assembly	68	GRTN1890	Hex.Soc.Hd.Bolt
26	GRTN300	Gasket	69	GRTN1920	Hex.Soc.Hd.Bolt
27	GRTN2920	End Cap	70	GRTN520	Spring
28	GRTN1930	Hex.Soc.Hd.Bolt	71	GRTN530	Latch
29	GRTN2220	O-Ring	72	GRTN500	Magazine Cap
30	GRTN2240	O-Ring	73	GRTN450	Bushing
31	GRTN630	Valve	74	GRTN2020	Hex.Soc.Hd.Bolt
32	GRTN2100	O-Ring	75	GRTN490	Bracket
33	GRTN2130	O-Ring	76	GRTN2080	Locknut
34	GRTN2170	O-Ring	77	GRTN1950	Hex.Soc.Hd.Bolt
35	GRTN640	Valve Plunger	78	GRTN2630	Flat Washer
36	GRTN830	Spring	79	GRTN2710	Cap Locknut
37	GRTN2230	O-Ring	80	GRTN310	Trigger Assembly Bump.
38	GRTN810	Plunger	81	GRTN4160	End Cap
39	GRTN820	Plunger Cap	82	GRTN4170	Belt Hook
40A	GRTN2930	Trigger Assy SEQ.	83	GRTN4200	O-Ring
41	GRTN2550	Spring Pin	84	GRTN4180	Spring Plate
42	GRTN790	Pin Trigger	85	GRTN4190	C-Ring
43	GRTN2210	Grommet	86	GRTN4210	Complete Belt Hook Assembly

- A GRDAK500 Driver Assembly Kit
- B GRRBK500 Rebuild Kit
- C GRTCHRH350MAN Operator's Manual
- D GRTCH350CASE Tool Case

GRTRH350 PARTS SCHEMATIC

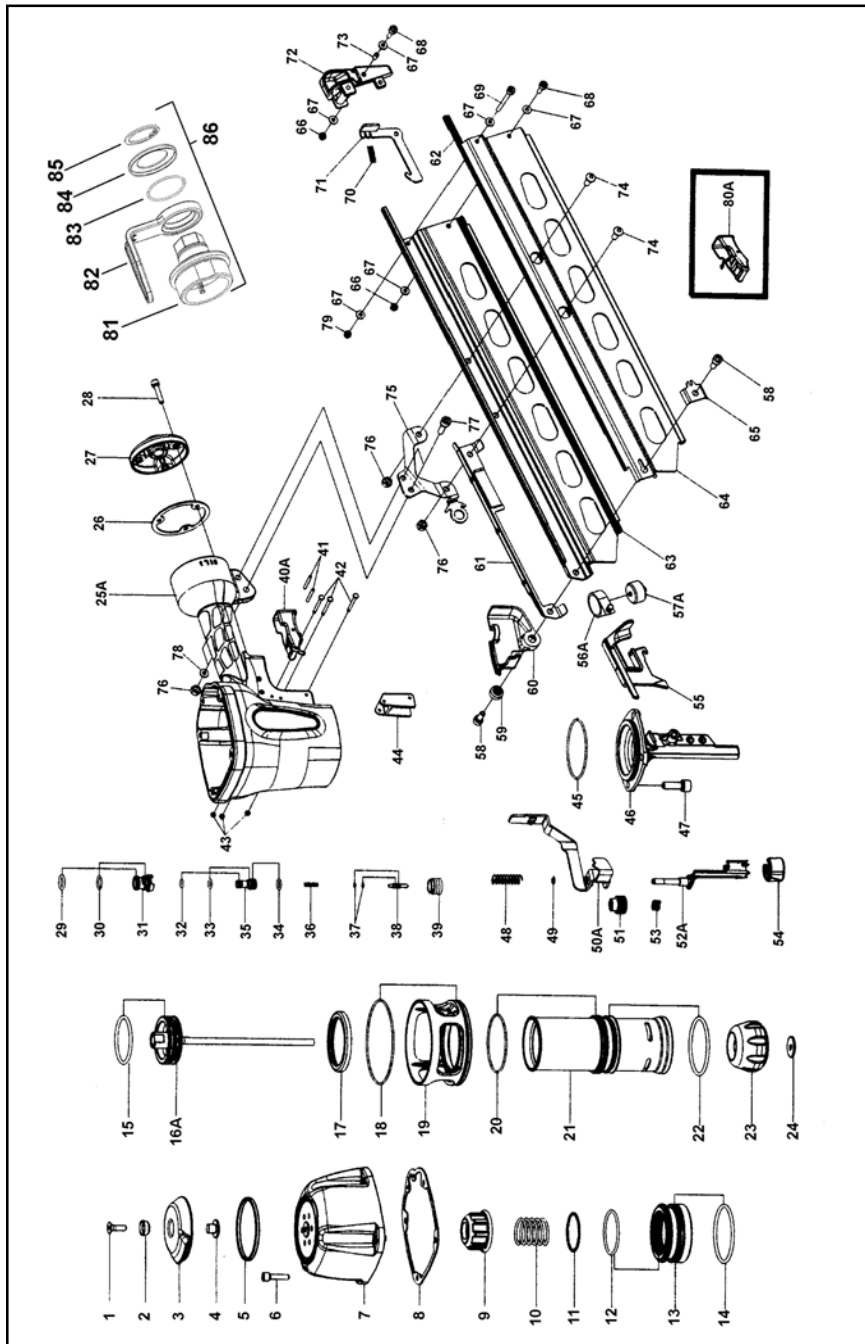

GRTRH350 PARTS LIST

ITEM	P/N	DESCRIPTION	ITEM	P/N	DESCRIPTION
1	GRTN2050	Hex.Soc.Hd.Bolt	44	GRTN370	Guide,Safety Lever
2	GRTN230	Washer	45	GRTN2440	O-Ring
3	GRTN170	Deflector	46	GRTN1490	Nose
4	GRTN160	Washer	47	GRTN2010	Hex.Soc.Hd.Bolt
5	GRTN2410	O-Ring	48	GRTN350	Spring,Safety
6	GRTN2000	Hex.Soc.Hd.Bolt	49	GRTN2670	E-ring
7	GRTN2900	Cap	50A	GRTN1500	Upper Safety Lever Assy.
8	GRTN180	Gasket	51	GRTN400	Adjusting Nut
9	GRTN190	Piston Stopper	52A	GRTN1510	Lower Safety Lever Assy.
10	GRTN210	Spring	53	GRTN410	Adjusting Spring
11	GRTN220	Washer	54	GRTN1530	Rubber Pad
12	GRTN2160	O-Ring	55	GRTN1560	Pusher
13	GRTN200	Piston,Head Valve	56A	GRTN460	Spiral Spring Assembly
14	GRTN2420	O-Ring	57A	GRTN470	Roller Pin Assembly
15	GRTN2200	O-Ring	58	GRTN1960	Hex.Soc.Hd.Bolt
16A	GRTN1470	Driver Assembly	59	GRTN330	Nose Cap Bushing
17	GRTN240	Seal	60	GRTN1520	Safety Cap
18	GRTN2460	O-Ring	61	GRTN1600	Magazine Cover
19	GRTN250	Cylinder Hold Down	62	GRTN1550	Nail Guide Liner
20	GRTN2430	O-Ring	63	GRTN1540	Magazine-Lower
21	GRTN260	Cylinder	64	GRTN1590	Magazine-Upper
22	GRTN2190	O-Ring	65	GRTN420	Bracket
23	GRTN280	Bumper	66	GRTN2060	Locknut
24	GRTN1480	Driver Guide	67	GRTN2620	Flat Washer
25A	GRTN2910	Body Assembly	68	GRTN1890	Hex.Soc.Hd.Bolt
26	GRTN300	Gasket	69	GRTN1920	Hex.Soc.Hd.Bolt
27	GRTN2920	End Cap	70	GRTN520	Spring
28	GRTN1930	Hex.Soc.Hd.Bolt	71	GRTN530	Latch
29	GRTN2220	O-Ring	72	GRTN1580	Magazine Cap
30	GRTN2240	O-Ring	73	GRTN450	Bushing
31	GRTN630	Valve	74	GRTN2020	Hex.Soc.Hd.Bolt
32	GRTN2100	O-Ring	75	GRTN3430	Bracket
33	GRTN2130	O-Ring	76	GRTN2080	Locknut
34	GRTN2170	O-Ring	77	GRTN3440	Hex.Soc.Hd.Bolt
35	GRTN640	Valve Plunger	78	GRTN2630	Flat Washer
36	GRTN830	Spring	79	GRTN2710	Cap Locknut
37	GRTN2230	O-Ring	80	GRTN310	Trigger Assembly Bump.
38	GRTN810	Plunger	81	GRTN4160	End Cap
39	GRTN820	Plunger Cap	82	GRTN4170	Belt Hook
40A	GRTN2930	Trigger Assy SEQ.	83	GRTN4200	O-Ring
41	GRTN2550	Spring Pin	84	GRTN4180	Spring Plate
42	GRTN790	Pin Trigger	85	GRTN4190	C-Ring
43	GRTN2210	Grommet	86	GRTN4210	Complete Belt Hook Assembly
A	GRDAK600	Driver Assembly Kit			
B	GRRBK600	Rebuild Kit			
C	GRTCHRH350MAN	Operator's Manual			
D	GRTRH350CASE	Tool Case			

TROUBLESHOOTING

TOOL TROUBLESHOOTING

Your pneumatic fastening tool has been designed for long life and trouble-free operation. However, if operating problems arise, please use the troubleshooting information below to determine how to remedy the problem.

DANGER

Always disconnect tool from air supply before performing any service on tool. Correcting a problem while the tool is pressurized may result in injury from fastener discharge or tool operation.

FASTENER DRIVING PROBLEMS

PROBLEM	CORRECTIVE ACTION
Fasteners do not drive completely.	AT TOOL: Turn adjustment dial to increase nail drive depth. Add 2 - 3 drops of air tool oil to inlet.
	AT COMPRESSOR: Increase air pressure. Do not exceed 120 psi/8.3 bar
Fasteners do not drive completely after air pressure is increased.	Driver blade worn or broken. See dealer for replacement.
Fasteners do not drive completely when driving in quick succession.	Inadequate air flow. Use larger diameter hose. Use compressor with larger storage tank. Keep hose lines short. Check air hose for kinks or other restrictions.
Fasteners drive too deeply.	AT TOOL: Turn adjustment dial to decrease nail drive depth.
	AT COMPRESSOR: Reduce air pressure. (Do not reduce below 70 psi/4.8 bar.)

TROUBLESHOOTING

FASTENER DRIVING PROBLEMS

Tool operates, but no fastener is driven.	Check magazine for jammed fastener. Clear jam and reload magazine. Check nail strip for smooth feeding in magazine.
Tool won't operate - nail jammed in tool nose, preventing tool from operating.	Remove jammed fastener. Check magazine for incorrect, bent, or loose fasteners, and discard. Reload using Grip-Rite™ nails.
Tool leaks air.	Check for source of leak, and tighten fittings and screws as required. Discontinue using tool if air leaks at trigger area or from cap exhaust. Contact your dealer.

TOOL CHECKS

Keep your nailer in top working condition by checking it daily. See your Grip-Rite® dealer for service if part or operating problems are found. Never use a malfunctioning tool - it could result in serious injury.

Workpiece Contact & Trigger

Check workpiece contact for proper operation before each use. Workpiece contact must move freely and return to extended position when lifted from workpiece. Trigger must operate freely.

Daily Inspection

- Check for broken, damaged, or excessively worn parts, and repair or replace as needed.
- Check for air leaks at trigger, cap, and nose. Disconnect tool from air supply immediately if leaks are present, and see dealer for service.
- Make sure all screws are tightened securely.

PNEUMATIC TOOL/COMPRESSOR WARRANTY

Pneumatic nailers, staplers & compressors marketed under the **GRIP RITE™** brand are warranted to be free from defects in workmanship & materials (except rubber o-rings, bumpers, seals, driver blades, dipsticks, & air filters) for a period of one year from the date of original purchase.

This warranty will not apply when:

- The original receipt (or copy of the original receipt), showing the original purchase date, is not provided with tools/compressors sent in for warranty repair
- The tool/compressor has been misused, abused or improperly maintained
- Alterations have been made to the original tool/compressor
- Repairs have been attempted/made to the original tool/compressor by any entity other than a proprietary **PRIMESOURCE®** service/warranty center or authorized service/warranty center
- Non- **GRIP-RITE TOOLS™ / GRIP-RITE COMPRESSORS™** parts have been used
- The tool has suffered any physical damage due to the use of non-**GRIP-RITE®** approved fasteners*
- Repairs are required due to normal wear & tear
- The tool/compressor has been inadequately packaged leading to damage in-transit to the service/warranty center.

*Approved fasteners include the following brands **GRIP-RITE FAS'NERS™, FAS'NERS UNLIMITED™**

IN NO EVENT SHALL **PRIMESOURCE®** BE LIABLE FOR ANY INDIRECT, ACCIDENTAL OR CONSEQUENTIAL DAMAGE FROM THE SALE OR USE OF THESE PRODUCTS. THIS DISCLAIMER APPLIES BOTH DURING & AFTER THE TERM OF WARRANTY.

THIS IS OUR WARRANTY & IS EXPRESSLY IN LIEU OF ALL OTHER WARRANTIES, EXPRESS OR IMPLIED, INCLUDING THE WARRANTIES OF MERCHANTABILITY AND FITNESS FOR A PARTICULAR PURPOSE (EXCEPT AS MAY BE OTHERWISE PROVIDED BY LAW).

THIS LIMITED WARRANTY GIVES YOU SPECIFIC LEGAL RIGHTS, AND YOU MAY ALSO HAVE OTHER RIGHTS, WHICH VARY, FROM STATE TO STATE.

PNEUMATIC TOOL/COMPRESSOR SERVICE INFORMATION

Should any mechanical problems develop during the life of your equipment the following options are available for service and parts:

- Call (800)676-7777 where you will be routed to the nearest **GRIP-RITE®** distribution center and directed to the nearest authorized service/warranty center.
- Logging on to our website at **www.grip-rite.com** where you will find a list of our authorized service centers.
- Contact the **GRIP-RITE®** Factory Warranty Center directly at Phone: (800)207-9259 or Fax: (800)207-9614
- In Canada, Call **(866) 512-1418**

STEPS TO TAKE WHEN SHIPPING TOOLS

- Adequately package the product to avoid damage in-transit (in the case of pneumatic tools, the original blow mold plastic carrying case is considered adequate packaging).
- Provide the original/copy of receipt showing the original purchase date.
- Insure your shipment with the shipping company.

PRIMESOURCE® will not be responsible for any tool/compressor that is lost or damaged by the shipper on route to the **PRIMESOURCE®** service/warranty center.

**USE GENUINE GRIP-RITE®
FASTENERS FOR BEST
PERFORMANCE**



Distributed by/Distribuido por/Imported by/Importé par:

PRIME SOURCE®
BUILDING PRODUCTS, INC.
and
BUILDING PRODUCTS CANADA CORPORATION
are Itochu Companies

Carrollton, Texas 75006 USA
www.grip-rite.com