

OWNER'S MANUAL

Model: 15-2N-ATV-GS (5303197)

(15 Gallon ATV Sprayer)

Technical Specifications

- 15 Gal. Corrosion-Resistant Polyethylene Tank
- 12 Volt Diaphragm Pump, 1.2 GPM - 60 PSI
- 15 Ft. Handgun Hose (3/8" I.D.)
- 12 Ft. Vertical throw, 20 Ft. Horizontal Throw
- 2-Nozzle Boom Assembly (80" Spray Coverage)
- Corrosion-Resistant Nylon Nozzles
- Check Valve Strainers, 50 Mesh, 5 PSI

This sprayer may be mounted to most makes of agricultural ATV vehicles.

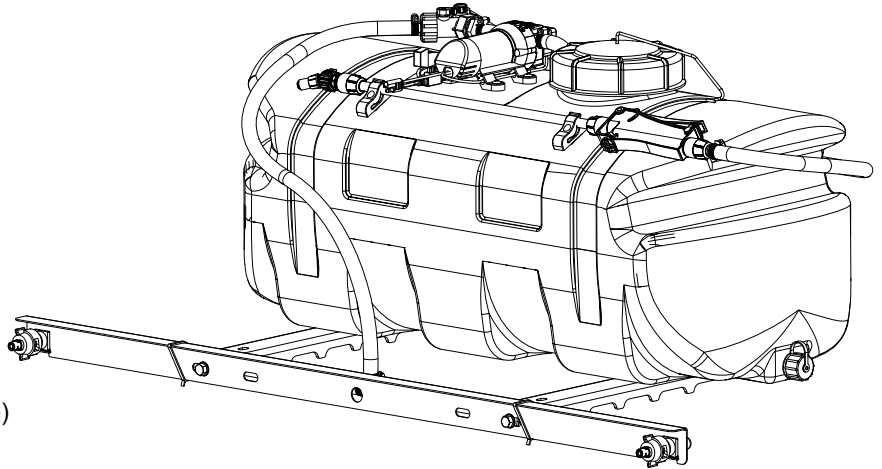

Caution: When fully filled with water, this sprayer will weigh approx. 160 lbs.. Consult the owner's manual for your vehicle to verify that you are within its load carrying capacity.

Assembly Instructions

- Make sure the contents of the sprayer's carton match the items shown on page 2 of the manual.
- Follow the steps on pages 2 & 3 to properly assemble the sprayer.
- After assembly is complete and before testing your sprayer, make sure you connect the electrical hook-up to the end of your pump and clip the clips to a fully charged battery.
- The drain plug assembly should already be attached to the tank
- Make sure all hose clamps are tight before testing or spraying for the first time.

General Information

Thank you for purchasing this product. The purpose of this manual is to assist you in operating and maintaining your lawn & garden ATV sprayer.



WARNING: To reduce the risk of injury, the user must read and understand the operator's manual before using this product.



WARNING: Cancer and Reproductive Harm
www.P65Warnings.ca.gov

BEFORE RETURNING THIS PRODUCT
FOR ANY REASON, PLEASE CALL

1-800-831-0027

MONDAY-FRIDAY, 8:00 AM TO 5:00 PM CST

If you should have a question or experience a problem with your Fimco Industries Product: Visit our website @ www.fimcoindustries.com or call the Toll free number above. Our technical support representatives will be happy to help you.

In most cases a customer service rep. can resolve the problem over the phone.

To obtain prompt, efficient service, always remember to give the following information...

- Correct Part Description and/or part number
- Model number and Serial Number

Part descriptions and numbers can be obtained from the illustrated parts list section(s) of this manual.

Retain a copy of your receipt for your unit, as it will be required to validate any warranty service.

Warranted against manufacturer or workmanship defects from date of purchase with copy of receipt:



Homeowner Usage: Sprayer-One Year and Pump-Two Years.

Commercial Usage: Sprayer and Pump-90 Days.

IMPORTANT REMINDER

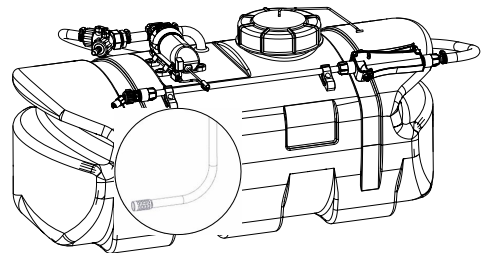

You must occasionally check and clean the strainer screen, located on the inside of the tank, especially if you experience a sudden loss of pressure.



www.fimcoindustries.com

1000 FIMCO Lane, P.O. Box 1700, North Sioux City, SD 57049
Toll Free Phone: 800-831-0027 : Toll Free Fax: 800-494-0440

[5195533

(10/20)]

Contents of your sprayer's carton (15-2N-ATV-GS):

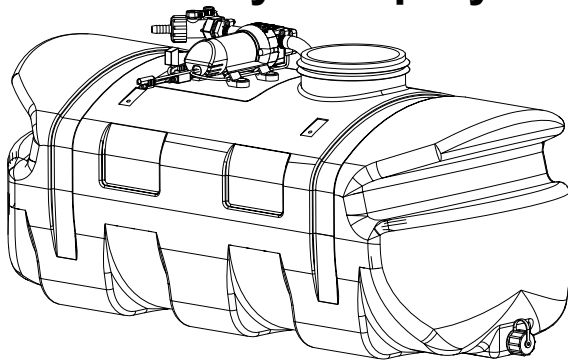

Tank Pre-Assembly

Owner's Manual

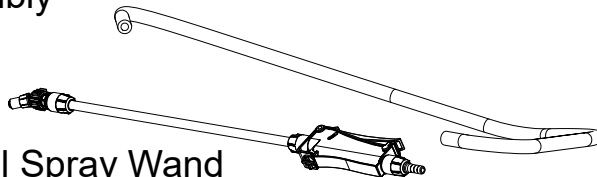

Entry Level Spray Wand & 15' Hose

Tank Lid & Lanyard

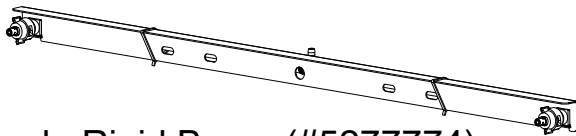
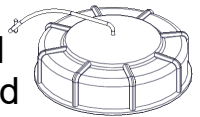

2-Nozzle Rigid Boom (#5277774)

Contents of Parts Bag

#5281752

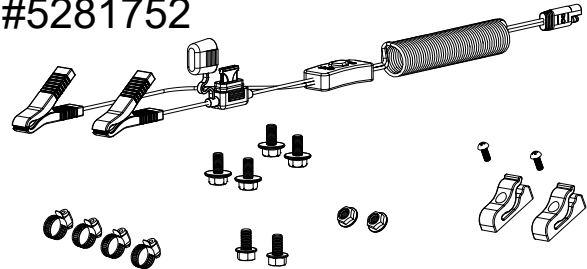

Ref. #	Part #	Description	Qty
1	5278017	Lead Wire Assembly w/5A Fuse (96" Long)	1
1.1	5157237	5 Amp Regular Blade Fuse	1
2	5051144	Hose Clamp (3/8")	4
3	5034531	5/16-18 x 0.625 Fling Hex Bolt (Locking Patch)	4
4	5034634	5/16-18 x 0.625 Fling Hex Bolt	2
5	5006307	5/16-18 Serrated Fling Hex Nut	2
6	5117334	#10-24 x 0.50 PH Round Head Mach Screw	2
7	5053096	Spray Wand Clip, for Blow-Molded Tanks	2

Contents of Bracket Kit #5281761

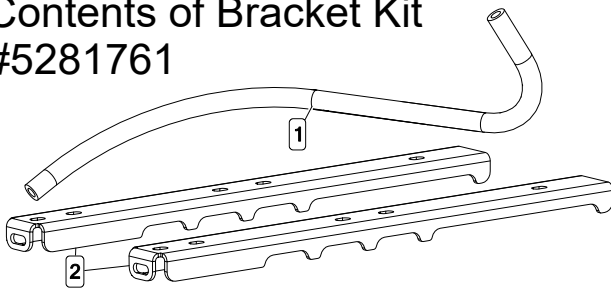

Ref. #	Part #	Description	Qty
1	5020531	Hose, 3/8"-1 Brd. x 19-3/8"	1
2	5038953	Fixed ATV Boom Bracket	2

Step 1

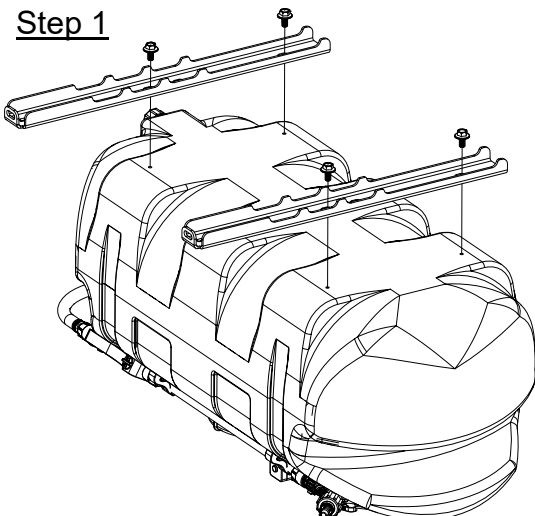

Assembly Procedure (15-2N-ATV-GS)

Right Hand (RH) and Left Hand (LH) sides of the sprayer are determined as if you are standing behind the sprayer, looking at it (facing forward)

After removing the tank from the box, start the assembly procedure by turning the tank upside on a stable, flat surface.

A 1/2" socket wrench is required for this step.

(**) Mount the tank brackets to the underside of the tank as shown in Step 1. Use (4) hex bolts to secure it to the tank. The tank will rest on the surface of the brackets. Make sure the brackets are parallel with each other before tightening down the bolts. Do not over-tighten.

Step 2

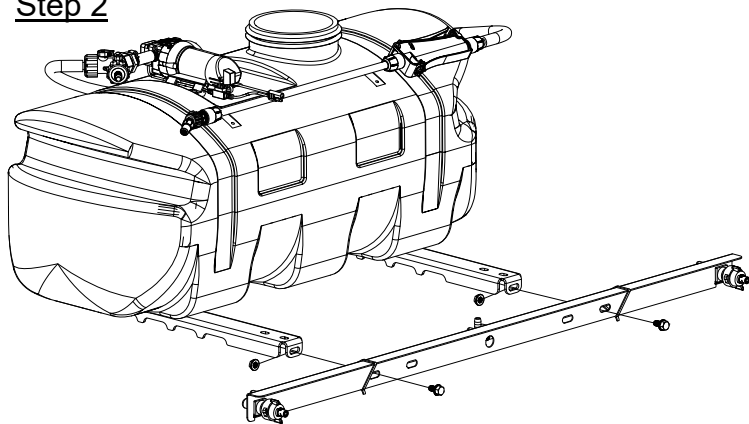

Assembly Procedure (15-2N-ATV-GS)

After your boom brackets are secured to the tank, turn the tank assembly over and position it so that the ends of the brackets extend beyond the back of the tank and hanging over the edge of the table or flat surface you are assembling this on.

1/2" socket wrench & wrench is required for this step.

Attach the boom assembly to the boom brackets, making sure the boom is centered. Secure in place with (2) flanged hex bolts and (2) flanged hex nuts.

After your boom is attached to the boom brackets, locate the feeder hose and the (2) hose clamps from the parts bag.

Place the hose clamps loosely over each end of the feeder hose. Slip the ends of the hose over the hose barbs on both the y-valve manifold and the barb fitting on the nozzle harness of the boom. Use a twisting motion, if necessary, to get the hose fully onto each barb. Bring the hose clamps to the connection point and tighten securely.

NOTE:

Make sure the boom feeder hose does not end up on the 'outside' of the spray wand hose, otherwise unwrapping the spray wand hose from around the tank may be difficult.

You are now ready to mount this unit to an ATV, using ratchet straps (NOT INCLUDED).

Step 4

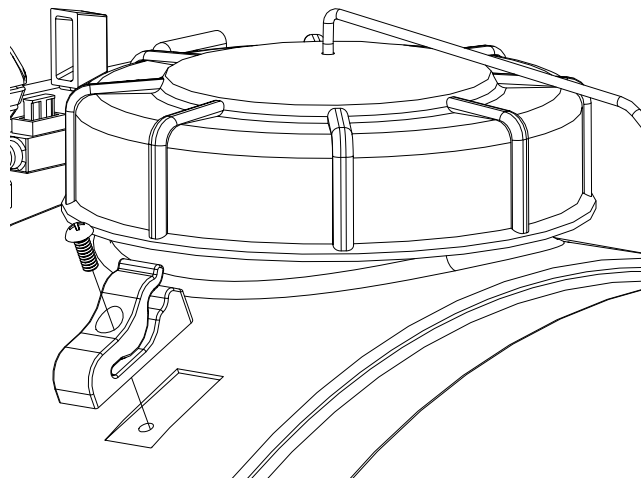

Place a hose clamp loosely over each end of handgun hose. Slip the ends of the hose over the hose barb on the y-valve manifold and the back of the spray wand. Use a twisting motion, if necessary, to get the hose fully onto each. Bring the hose clamps to the connection point and tighten securely.

You are now ready to mount this unit to an ATV, using ratchet straps (NOT INCLUDED).

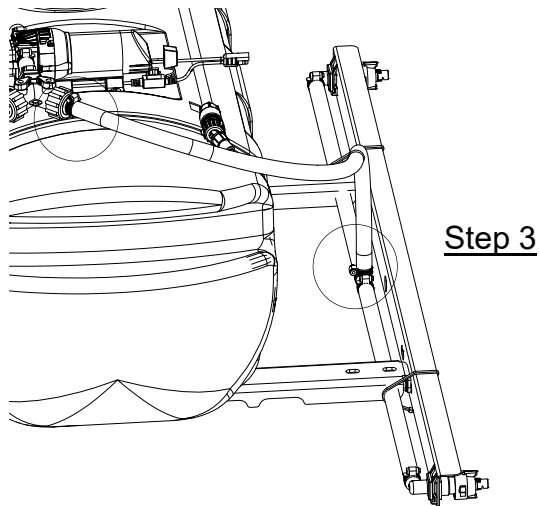

Step 3

Screw the lid onto the tank.

Locate the (2) clips and (2) phillips head machine screws from the parts bag.

A phillips head screwdriver is required for this step

Place a screw through the hole in the clip and bring it up to the tank, where the embossments for the clips are (located on the rear side of the tank) Secure the clip/screw to the tank. Tighten so that the clip is secure. Do this for each clip.

**** DO NOT OVER-TIGHTEN ****

The spray wand will snap into the clips once installed. Do not use excessive force when placing the spray wand into the clips, as this could cause the clips to break.

Step 5

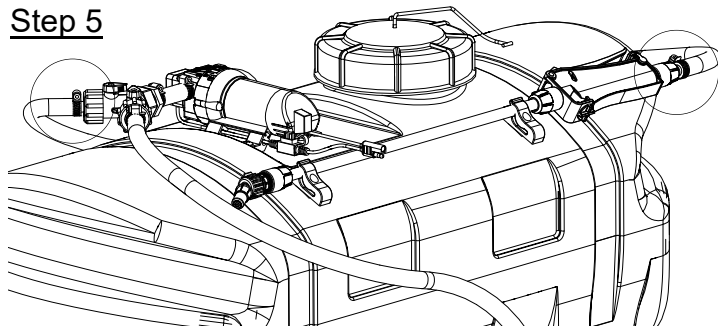

***** The Sprayer should now be ready for use *****

IMPORTANT: Remove tank lid and be sure the tank is clean and free of any foreign material. Rinse tank out of any tank residue before filling with water to test. Make sure all hose clamps are tight.

Testing the Sprayer

NOTE:

It is VERY important for you to test your sprayer with plain water before actual spraying is attempted. This will enable you to check the sprayer for leaks without the possibility of losing any expensive chemicals.

Fill the tank about 1/2 full with plain water and drive to the starting place for spraying.

When you are ready to spray, open the boom valve to the "on" position (see boom valve open). This will start solution spraying from the tips of the boom. The pressure will decrease slightly when the boom is spraying.

Read the operating instructions and initially begin spraying by opening the boom line valve. This will enable the air in the line to be eliminated (purged) through all the tips, while building pressure. When everything tests all right, add the desired chemicals to the mixture and water combination and start your spraying operation.

Conditions of weather and terrain must be considered when setting the sprayer. Do not spray on windy days.

Protective clothing must be worn in some cases.

Be sure to read the chemical label(s) before application!

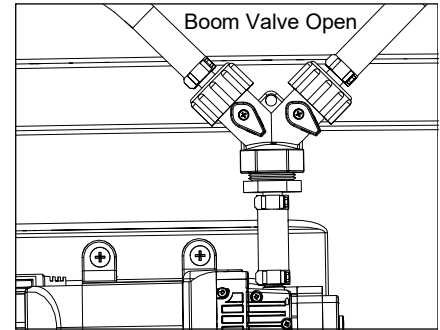
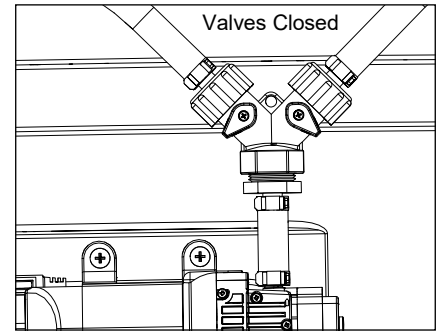

Operation

The pumping system draws solution from the tank, through the strainer and to the pump. The pump forces the solution under pressure to the handgun or boom nozzles.

Connect the lead wire to a fully charged 12 volt battery. You may use either a stand-alone battery or the battery on your towing vehicle. Connect to the positive (red) terminal first, then connect to the negative (black) terminal. Then connect the end of the lead wire to the end of the pump. When disconnecting, disconnect the end of the pump wire from the lead wire, then disconnect the negative (black) connection and finally the positive (red) connection. The lead wire has an On/Off switch to activate the pump. "-" is on and "O" is off.

Fill the tank part way with water and then add the desired amount of chemical to be sprayed. Finish filling tank to proper level. Turn the pump on and by depressing the "-" side of the rocker switch. The pump is equipped with a pressure switch that is pre-set at the factory to shut the pump off when all discharges are closed.

The pump will turn back on when one of the following actions occurs:

- ◆ Handgun lever is squeezed to spray the handgun.
- ◆ Boom valve is opened to broadcast spray with the boom.

Maintenance During/After Spraying

Periodically check the strainer and clean the screen on your intake line.

Proper care and maintenance will prolong the life of your sprayer.

After use, drain the tank and store or dispose of chemical properly. Fill the sprayer half way with clean water. Start the pump and allow the water to pump through the entire plumbing system and nozzles. Drain and then refill half full, add the recommended amount of a good quality tank cleaner, such as FIMCO Tank Neutralizer and Cleaner. (If no tank cleaner is available, you may substitute dish soap for this step, about 1-2 oz. per gallon). Turn pump on and circulate through system for 15 minutes and then spray out through boom and handgun nozzles. Refill sprayer half way with clean water and repeat. Follow the chemical manufacturer's disposal instructions of all wash or rinsing water.

If boom or handgun nozzles need cleaning, remove them from the sprayer and soak in warm soapy water. Clean with a soft bristled brush or toothpick if necessary. Never use a metal object. Even the slightest damage can change the flow rate and spray distribution. Water rinse and dry the tips before storing.

WARNING: Some chemicals will damage the pump valves if allowed to soak untreated for a length of time! ALWAYS flush the pump as instructed after each use. DO NOT allow chemicals to sit in the pump for extended times of idleness. Follow the chemical manufacturer's instructions on disposal of all waste water from the sprayer.

Winter Storage

Prepare the sprayer for end-of-season storage by running RV antifreeze through the system. This will keep internal parts lubricated, protect against corrosion and keep the unit from freezing. *Note: RV antifreeze is non-toxic and biodegradable and generally safer for the environment than automotive antifreeze.*

Before storing your sprayer for winter or long term storage, thoroughly clean and drain it as much as possible. Then pour enough pink RV antifreeze into the tank so that when the pump is turned on you can pump the antifreeze throughout the entire plumbing system. Make sure to operate the boom and handgun until you see pink fluid spraying from the nozzles. Leave any remaining antifreeze in the tank. Before your next usage, rinse the antifreeze from the sprayer with clean water.

It is nearly impossible to drain all of the water from the sprayer and any trapped water can freeze in cold weather and damage parts of the sprayer. Pumping the antifreeze through the system will displace the water and help prevent this damage.

Removing from storage: drain the antifreeze. Fill the tank with fresh water and run through the system. Dispose of antifreeze and flush water properly.

STOP WARNING STOP

DO NOT USE PUMP IN AN EXPLOSIVE ENVIRONMENT. DO NOT USE TO PUMP FLAMMABLE/COMBUSTIBLE FLUIDS, GASOLINE, KEROSENE, FUEL, OIL, ETC.

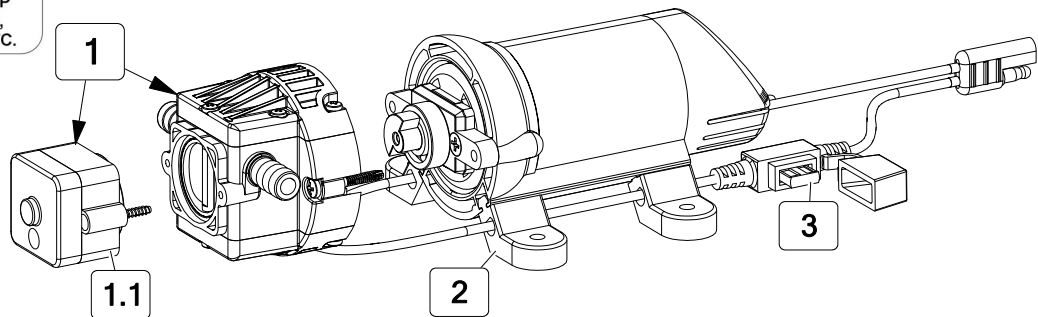

Pump Model: 5281370
 Available
 Replacement Parts
 Replacement Pump: 5151086

Ref. #	Part #	Description	Qty
1	5164272	1.2 GPM Pump Head	1
1.1	5164271	60 PSI Pressure Switch Assembly	1
2	5095202	Pump Mount Feet (4 Pack)	1
3	5157204	5 Amp 'Mini Blade' Fuse	1

DO

- Clean and rinse your pump after each use with Fimco Tank Neutralizer
- Winterize your pump or sprayer by rinsing, draining and running RV Antifreeze through it before storing for the winter.
- Use clean water for your spray mixture
- Store inside a building when not in use.

DON'T

- Use to pump bleach.
- Use to pump petroleum products such as diesel fuel, gasoline or kerosene
- Leave your pump sit with spray mixture in it for extended periods
- Use dirty or unfiltered water for spraying

CAUTION

PRESSURE SWITCH OPERATION

Pressure switch is pre-set at the factory. Improper adjustment of the pressure switch, may cause severe overload or premature failure. If the pump is subjected to rapid cycling during normal operation, or infrequent periods, damage may occur.

Troubleshooting the Pump:

Motor does not run:

- Check for loose wiring connection(s).
- Make sure the 'ON/OFF' switch in the lead wire assembly is in the 'ON' position. "I" is the 'ON' position and 'O' is the 'OFF' position.
- Check for defective pressure switch. Make sure you are connected to a good 12 volt power source. Make sure any on/off switches are in the 'on' position. Remove the cap to the pressure switch. Pull both red wires off of their terminals, and touch the two ends together. If your pump runs when you do this, your pressure switch will need to be replaced.
- Check the fuse.
- Check for low voltage at the power supply.

Pump does not prime:

- Check for air leaks in supply line.
- Check for debris in the check valve assembly.
- Check for defective check valve.
- Check for clogged strainer/filter.
- Check for cracks in the pump housing.
- Check for empty product supply.

Low Pressure/Low Flow:

- Check for leaks in the discharge line.
- Check for restriction in the discharge line.
- Check for debris in nozzle orifice.
- Check for clogged strainer.
- Check for proper voltage—try another 12-volt battery.

Pulsating flow (surging):

- Low flow may cause pump to surge.
- Spray wand is adjusted for a small or fine spray pattern.
- If needed, pressure switch may need to be adjusted—adjust a quarter turn at a time clockwise until surging stops.
- Check for defective pressure switch.
- Check for leaks in the discharge line.
- Check for restriction in the discharge line.
- Check for debris in nozzle orifice.
- Discharge hose may be too long.
- Check for clogged strainer.

Motor continues to run after discharge is shut off:

- Check for empty product supply.
- Check for low voltage.
- Check for leak in discharge line.
- Check for defective pressure switch.
- System has leaks.

Fuse blows:

- Excessive voltage.
- Improper adjustment of pressure switch.
- Damaged or defective wiring harness.
- Half-moon & counterweight are sticking.
- Defective pressure switch.

Motor not running: Checking the Pressure Switch.

If your motor is not running and you've checked the following: for loose wiring connections, fuse, the switch on the lead wire was "ON" and made sure you were connected to a fully charged battery and everything is fine, but the motor won't run, then it's time to check to see if the pressure switch is bad.

- Remove the cover off the 1" square box (pressure switch) on the head of the pump, the cover is held on by one phillips-head screw. This will expose the two red wires.
- With the pump connected to a good 12 volt power source and everything on.
- Slip the two red wires off the terminals and touch them together.

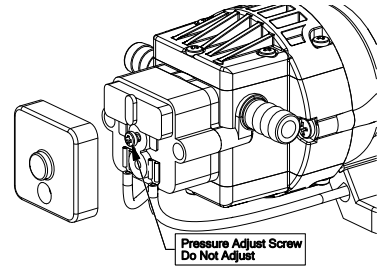

If the motor runs, it means the pressure switch is bad and needs to be replaced.

If it still doesn't run, try bypassing the switch in the lead wire or using another lead wire. Even if a tester shows power to the pressure switch, it still could be the switch in the wire that is causing the problem.

If still not responsive, use a voltmeter or electrical tester to make sure you are getting power to the head of the pump, as it could possibly be something in one of the wires or even the lead wire assembly may need to be replaced.

Warning: It is NOT recommended to run the pump this way, as the pump will continue to run and not shut off. This could result in blown hoses when all discharges are closed. Also, this could result in premature failure of the pump completely.

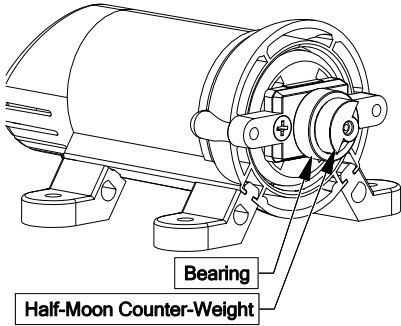

Little to No Pressure: Motor runs, but no pressure:

If your strainer is clean....

CHECK:

Both the counterweight and the bearing need to spin freely and both need to spin INDEPENDENTLY of each other. If these 2 pieces are 'stuck' together, you will need to break them free and whether or not they are sticking, spray some good quality lubricant or something similar on them and let it soak in and this should restore most of your prime.

Troubleshooting	
Pump will not run:	Check for loose wiring
	Make sure the ON/OFF switch is on on lead wire.
	Check the fuse
	Check for defective pressure switch
Low Pressure/Low Flow:	Check for a clogged strainer
	Check for proper voltage Try another 12-Volt battery
Pump surges:	Low flow may cause pump to surge
	Spray wand is adjusted for a small or fine spray pattern
	If needed, pressure switch may need to be adjusted Quarter turn at a time clockwise until surging stops
Pump continues to run:	System has leaks
Fuse blows:	Excessive voltage
	Improper adjustment of pressure switch
	Damaged or defective wiring harness
	Half-moon & Counterweight are sticking
	Defective pressure switch

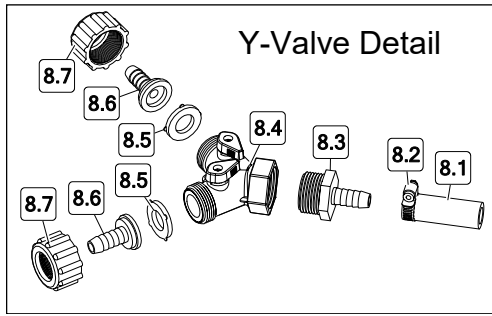

Exploded View/Parts List: 15-2N-ATV-GS (5303197)

Refer below for part numbers

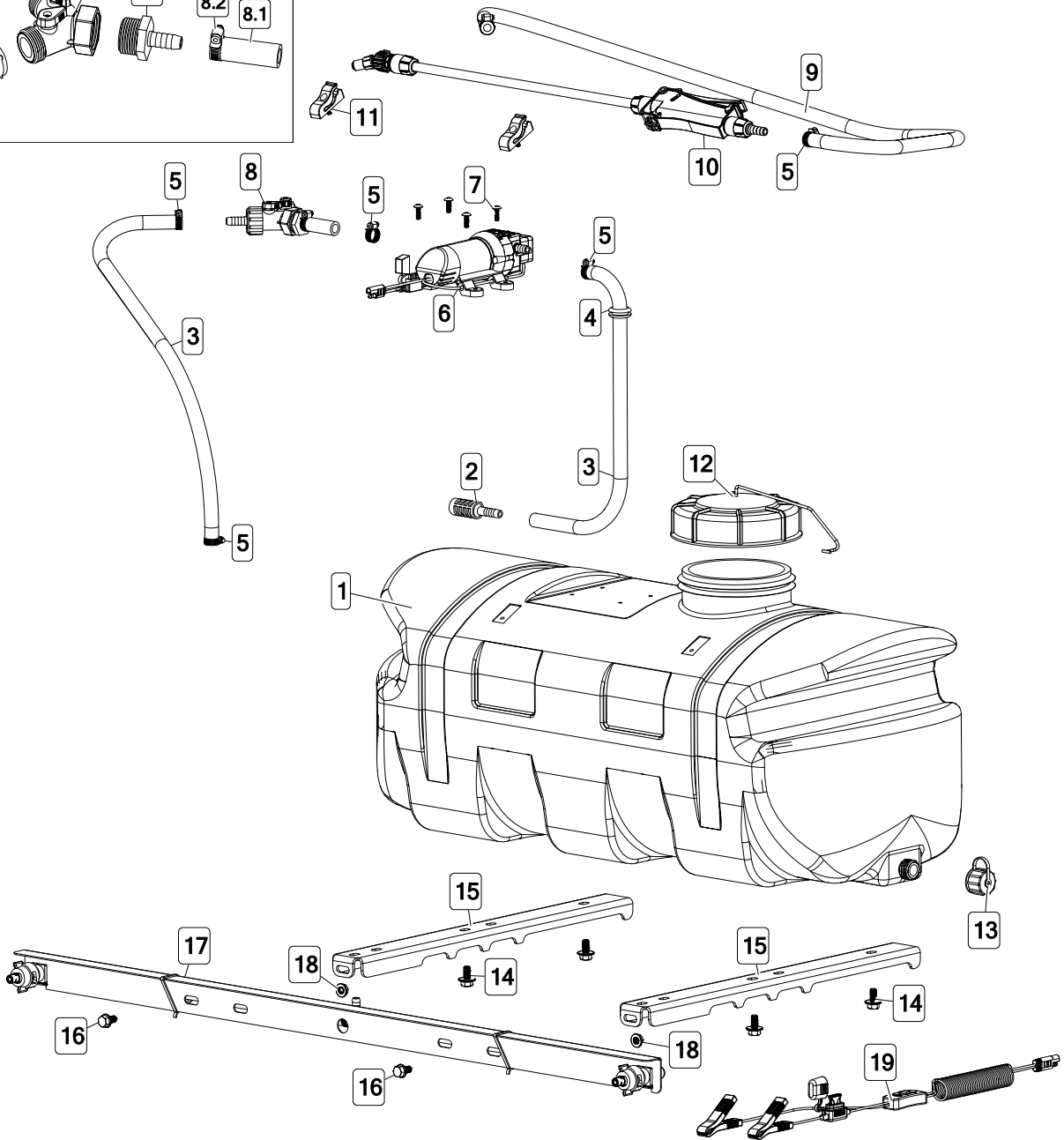

Ref. #	Part #	Description	Qty
1	TA15W	15 Gallon Tank (White)	1
2	5116454	3/8" Hose Barb Suction Strainer	1
3	5020531	Hose, 3/8"-1 Brd. x 19-3/8"	2
4	5075022	Grommet (5/8" I.D.)	1
5	5051144	Hose Clamp (3/8")	6
6	5281370	1.2 GPM, 60 PSI, 12V Pump	1
7	5117167	#10-24 x 0.625 PH Truss Head Mach Screw	4
8	5281753	Y Valve Assembly	1
8.1	5020343	Hose, 3/8"-1 Brd. x 2"	1
8.2	5051144	Hose Clamp, 3/8"	1
8.3	5067120	Poly Fitting, 3/4" MGHT x 3/8" HB	1
8.4	5143204	Dual Hose Shut-Off "Y" Valve	1
8.5	5016066	1" Rubber Washer	2
8.6	5149034	Poly Swivel, 3/8" Hose Barb	2
8.7	5006209	Poly Knurled Swivel Nut, 3/4" FGHT	2

Ref. #	Part #	Description	Qty
9	5020524	Hose, 3/8"-1 Brd. x 15 Ft.	1
10	5163154	Entry Level Spray Wand	1
10.1	5018313	Adjustable ConeJet Tip (X18)	1
11	5274880	Wand Clips & Screws (Pkg/2)	1
12	5058188	Tank Lid w/Lanyard	1
13	5274373	Drain Plug Assembly	1
14	5034531	5/16-18 x 0.625 Fling Hex Bolt (Locking Patch)	4
15	5038953	Fixed ATV Boom Bracket	2
16	5034634	5/16-18 x 0.625 Fling Hex Bolt	2
17	5277774	2-Nozzle Rigid Trailer Boom (QJ)	1
18	5006307	5/16-18 Serrated Fling Hex Nut	2
19	5278017	Lead Wire Assembly w/5A Fuse (96" Long)	1
19.1	5157237	5 Amp Regular Blade Fuse	1

2-Nozzle Boom Assembly Exploded View/Parts List

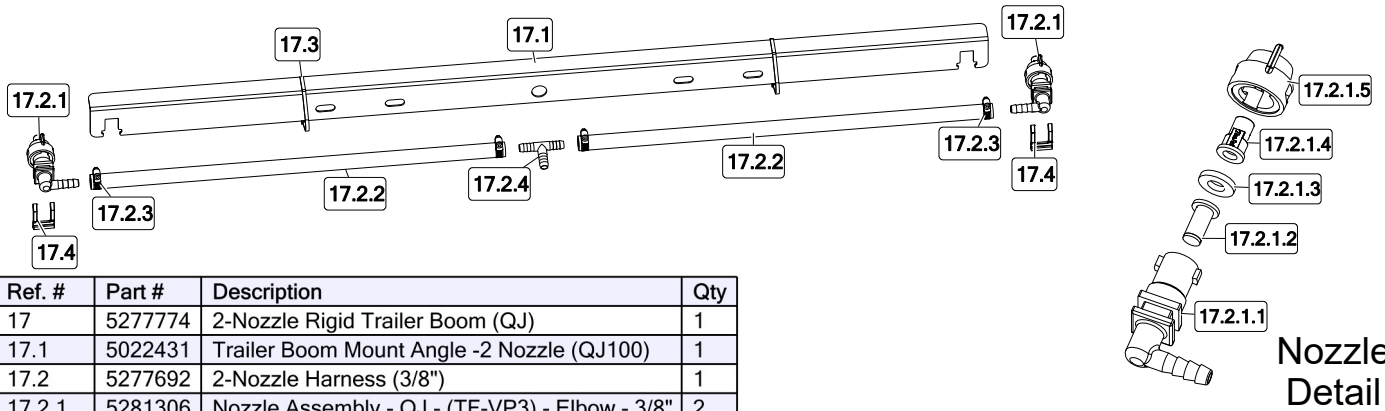

Ref. #	Part #	Description	Qty
17	5277774	2-Nozzle Rigid Trailer Boom (QJ)	1
17.1	5022431	Trailer Boom Mount Angle -2 Nozzle (QJ100)	1
17.2	5277692	2-Nozzle Harness (3/8")	1
17.2.1	5281306	Nozzle Assembly - QJ - (TF-VP3) - Elbow - 3/8"	2
17.2.1.1	5056113	Nozzle Body - QJ - Elbow - 3/8"	1
17.2.1.2	5143543	Nozzle Check Strainer, Blue (50 Mesh)	1
17.2.1.3	5016157	Seat Washer - EPDM - QJ Caps	1
17.2.1.4	5018274	Turbo FloodJet Tip (TF-VP3)	1
17.2.1.5	5046251	Quick Cap - Black	1
17.2.2	5020531	Hose, 3/8"-1 Brd. x 19-3/8" NBR & PVC	2
17.2.3	5051144	Hose Clamp (3/8")	4
17.2.4	5086025	Poly Hose Tee, 3/8" HB	1
17.3	5133094	Nylon Cable Tie	2
17.4	5053110	Plastic Retaining Clip	2

Based on the minimum overlap required to obtain uniform distribution with 120° tips and 40" spacing.

Suggested Minimum Spray Height: 18"-20" above what is being sprayed (to plant, not ground).

Optimum Spray Height: 39"

Wide angle spray nozzle height is influenced by nozzle orientation. The critical factor is to achieve a minimum 30% overlap.

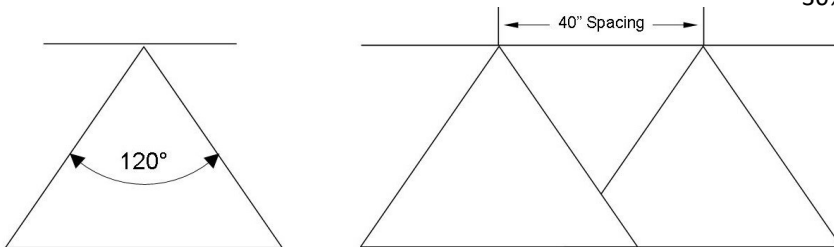

- Excellent spray distribution for uniform coverage along the boom.
- Nozzle design incorporates a pre-orifice to produce larger droplets for less drift.

For the safest and most efficient chemical application, you will need to calibrate your sprayer using the tip and speed charts. Once you have determined the proper speed and pressure settings (this sprayer will spray at the 30 PSI range from the chart below), you will need to consult your chemical label for the amount of chemical to be added to the tank. Read the entire label. Use only according to label directions.

Calibration

Chemical labels may show application rates in gallons per acre, gallons per 1000 square feet or gallons per 100 square feet. You will note that the tip chart shows 3 of these rating systems. Once you know how much you are going to spray, then determine (from the tip chart) the spraying pressure (30 PSI), and the spraying speed (MPH).

Determining the proper speed of the pulling vehicle can be done by marking off 100, 200 & 300 feet. The speed chart indicates the number of seconds it takes to travel the distances. Set the throttle and with a running start, travel the distances. Adjust the throttle until you travel the distances in the number of seconds indicated by the speed chart. Once you have reached the throttle setting needed, mark the throttle location so you can stop and go again, returning to the same speed.

Add water and proper amount of chemical to the tank and drive to the starting place for spraying.

Speed Chart			
Speed in M.P.H. (Miles Per Hour)	Time Required in seconds		
	100 Ft.	200 Ft.	300 Ft.
1.0	68 sec.	136 sec.	205 sec.
2.0	34	68	102
3.0	23	45	68
4.0	17	34	51
5.0	14	27	41
6.0	11	23	34
7.0	9.7	19	29
8.0	8.5	17	26
9.0	7.6	15	23
10.0	6.8	14	20

Tip Chart for TKT-VP3, TF-VP3 & 30DT3.0 Tips									
Tip No. (Color)	Pressure (psi)	Capacity (GPM)	Gallons Per Acre - Based on Water						
			1 MPH	2 MPH	3 MPH	4 MPH	5 MPH	7.5 MPH	10 MPH
3 (Gray)	10	.30	44	22	14.9	11.1	8.9	5.9	4.5
	20	.42	63	31.5	20.9	15.7	12.6	8.4	6.3
	30	.52	76	38	26	19.3	15.4	10.3	7.7
	40	.60	90	45	30	22	17.8	11.8	8.9
Tip No. (Color)	Pressure (psi)	Capacity (GPM)	Gallons Per 1000 Sq. Ft. - Based on Water						
			1 MPH	2 MPH	3 MPH	4 MPH	5 MPH	7.5 MPH	10 MPH
3 (Gray)	10	.30	1.01	.5	.34	.254	.204	.135	.103
	20	.42	1.4	.72	.48	.36	.29	.19	.14
	30	.52	1.74	.87	.596	.44	.35	.236	.176
	40	.60	2.06	1.00	.688	.50	.408	.27	.20
Tip No. (Color)	Pressure (psi)	Capacity (GPM)	Gallons Per 100 Sq. Ft. - Based on Water						
			1 MPH	2 MPH	3 MPH	4 MPH	5 MPH	7.5 MPH	10 MPH
3 (Gray)	10	.30	.10	.05	.034	.025	.02	.013	.01
	20	.42	.14	.072	.048	.036	.029	.019	.014
	30	.52	.174	.087	.059	.044	.035	.023	.017
	40	.60	.206	.10	.068	.05	.04	.027	.02

NOTES:

Warranty

LIMITED WARRANTY FOR NEW FIMCO, IND. EQUIPMENT

WHO MAY USE THIS LIMITED WARRANTY. This limited warranty (the "Limited Warranty") is provided by Fimco, Ind. to the original purchaser ("you") of the Equipment (as defined below) from Fimco, Ind. or one of Fimco, Ind.'s authorized dealers. This Limited Warranty does not apply to any subsequent owner or other transferee of the Equipment. THIS LIMITED WARRANTY GIVES YOU SPECIFIC LEGAL RIGHTS, AND YOU MAY ALSO HAVE OTHER RIGHTS WHICH VARY FROM STATE TO STATE.

WHAT THIS LIMITED WARRANTY COVERS AND FOR HOW LONG. Fimco, Ind. warrants that any new Equipment will be free from defects in material and workmanship for a period of **one (1) year** for sprayer and **two (2) years** for High-Flo High Performance pump (homeowner), **90 days** for sprayer and pump (commercial user), after delivery of the Equipment to you (the "Warranty Period"). The Warranty Period is not extended if Fimco, Ind. repairs or replaces the Equipment.

WHAT IS NOT COVERED BY THIS LIMITED WARRANTY. This Limited Warranty does not apply to: (1) used Equipment; (2) any Equipment that has been altered, changed, repaired or treated since its delivery to you, other than by Fimco, Ind. or its authorized dealers; (3) damage or depreciation due to normal wear and tear; (4) defects or damage due to failure to follow Fimco, Ind.'s operator's manual, specifications or other written instructions, or improper storage, operation, maintenance, application or installation of parts; (5) defects or damage due to misuse, accident or neglect, "acts of God" or other events beyond Fimco, Ind.'s reasonable control; (6) accessories, attachments, tools or parts that were not manufactured by Fimco, Ind., whether or not sold or operated with the Equipment; or (7) rubber parts, such as tires, hoses and grommets.

HOW TO OBTAIN WARRANTY SERVICE. To obtain warranty service under this Limited Warranty, you must (1) provide written notice to Fimco, Ind. of the defect during the Warranty Period and within **thirty (30) days** after the defect becomes apparent or the repair becomes necessary, at the following address: Fimco, Ind., 1000 Fimco Lane, North Sioux City, SD 57049; and (2) make the Equipment available to Fimco, Ind. or an authorized dealer within a reasonable period of time. For more information about this Limited Warranty, please call: **800-831-0027**.

WHAT REMEDIES ARE AVAILABLE UNDER THIS LIMITED WARRANTY. If the conditions set forth above are fulfilled and the Equipment or any part thereof is found to be defective, Fimco, Ind. shall, at its own cost, and at its option, either repair or replace the defective Equipment or part. Fimco, Ind. will pay for shipping and handling fees to return the repaired or replacement Equipment or part to you.

LIMITATION OF IMPLIED WARRANTIES AND OTHER REMEDIES. THE REMEDIES DESCRIBED ABOVE ARE YOUR SOLE AND EXCLUSIVE REMEDIES, AND FIMCO, IND.'S SOLE LIABILITY, FOR ANY BREACH OF THIS LIMITED WARRANTY. TO THE EXTENT APPLICABLE, ANY IMPLIED WARRANTIES, INCLUDING, WITHOUT LIMITATION, THE IMPLIED WARRANTIES OF MERCHANTABILITY AND FITNESS FOR A PARTICULAR PURPOSE, SHALL BE LIMITED IN DURATION TO THE WARRANTY PERIOD, AND THE REMEDIES AVAILABLE FOR BREACH THEREOF SHALL BE LIMITED TO THE REMEDIES AVAILABLE UNDER THIS EXPRESS LIMITED WARRANTY. SOME STATES DO NOT ALLOW LIMITATIONS ON HOW LONG AN IMPLIED WARRANTY LASTS, SO THE ABOVE LIMITATION MAY NOT APPLY TO YOU. IN NO EVENT SHALL FIMCO, IND.'S LIABILITY UNDER THIS LIMITED WARRANTY EXCEED THE ACTUAL AMOUNT PAID BY YOU FOR THE DEFECTIVE EQUIPMENT, NOR SHALL FIMCO, IND. BE LIABLE, UNDER ANY CIRCUMSTANCES, FOR ANY CONSEQUENTIAL, INCIDENTAL, SPECIAL OR PUNITIVE DAMAGES OR LOSSES, WHETHER DIRECT OR INDIRECT. SOME STATES DO NOT ALLOW THE EXCLUSION OR LIMITATION OF INCIDENTAL OR CONSEQUENTIAL DAMAGES, SO THE ABOVE LIMITATION OR EXCLUSION MAY NOT APPLY TO YOU.