



# Diamond<sup>®</sup> Horseshoes & Farrier Tools



# Knowing hands trust Diamond.



You can count on Diamond to provide the closest fit, smoothest finish, and longest life every time you pick up your hammer. But it's more than that. Diamond is the only name that has a full line of shoes, nails, tools, and rasps – all designed to work beautifully together.

Diamond ... providing professional quality and exceptional value for over 100 years.

[www.diamondfarrier.com](http://www.diamondfarrier.com)

# Diamond® Horseshoes and Farrier Tools



## It all started with two employees and one new idea.

Armed with a patented new idea for a drive calk for horseshoes, the Diamond® Calk Horseshoe Company was formed in Duluth, Minnesota in 1908. Starting with two employees and a dedication to hard work and quality products, the new company embarked on the beginning of a very successful venture. In 1912, Diamond added a full line of drop-forged horseshoes. Other forged tools were added to meet the demand for quality products during World War I.

*Since 1908, discriminating horse owners and suppliers have depended on the Diamond brand for high quality farrier products*

Today, Diamond continues to be America's premier brand in farrier products. We're one of the largest suppliers of regular, special purpose, mule, and pony shoes in the world. In all, over 100 shoes and hand tools carry the Diamond name.

Since 1908, discriminating horse owners and suppliers have depended on the Diamond brand for high quality farrier products. Now worldwide in scope, you can continue to rely on Diamond for as long as there are horses.

With Diamond, you can buy a full line of farrier tools, horseshoes, and nails from one source. And since Diamond is part of Apex Tool Group, you can also purchase from its extensive line of quality products, including Campbell® chain, Crescent® brand wrenches, Lufkin® measuring products, Nicholson® files, Plumb® hammers, H.K. Porter® cutters, Weller® soldering tools and Wiss® snips.

## Table of Contents

Contents	Page No.
Miscellaneous Information	2
Diamond Classic Shoes	3
Diamond Special Shoes	4
Bronco Shoes	4 - 5
Hind Shoes	5
Pony Shoes	5
Rim Shoes	5
Toe Weights Shoes	6
Clipped Shoes	6
Competitor Shoes	6
Draft Shoes	7
Plastic Hoof Pad	7
Horseshoe Nails	7

Contents	Page No.
Farrier Tools - Nippers	8
Farrier Tools - Spreader, Nail Puller, Tongs	9
Rasps and Files	9 - 11
File Handles and Cleaner	11
Hoof Knives	11
Clinchers, Clinch Cutter, Clinch Block	12
Pritchel	12
Fence Tools	13
Measuring Tapes, Hoof Pad Cutter	14
Specialty, Ball Pein, Engineer, & Blacksmith Hammers	14 - 15
Farrier Tool Assortment	15
Numeric Index	16

---

## Competitive Advantage

**Diamond® Farrier products have the competitive advantage in value, quality and availability**

- Complete selection of shoes and tools for the farrier trade
- Diamond® horseshoes are reworkable, whether cold or reheated
- Available through distributors of heavy hardware plus ranch and veterinary supply houses

---

## Ordering Information

To find the nearest Distributor or Dealer near you, please call an Apex Tool Group Customer Service Representative -

Phone: (919) 362-1670

Fax: (877) 387-0415

---

## Safety

Farrier tools should be used only for their designed purposes and within their size ranges. The following cautions should always be observed:

1. **Always wear approved eye protection.**
2. Never use nippers, pullers or pliers as hammers or hammer on their handles.
3. Do not extend nipper, puller or plier handle lengths to achieve greater leverage. Use a larger tool.
4. When using a hammer, strike squarely – avoid glancing blows that may cause the edge of the face to slip, possibly resulting in eye or other serious injury. **Never strike with or against the side or cheek of any hammer.**
5. Do not use special purpose hammers for anything but the purposes for which they were intended.
6. **Never use a hammer with a loose or damaged handle.**
7. **Do not misuse tools. Nail Cutting Nipper can chip if used beyond cutting nails - DO NOT PULL OR APPLY EXCESSIVE TORQUE WHILE CUTTING NAILS.**

## Classic Shoes

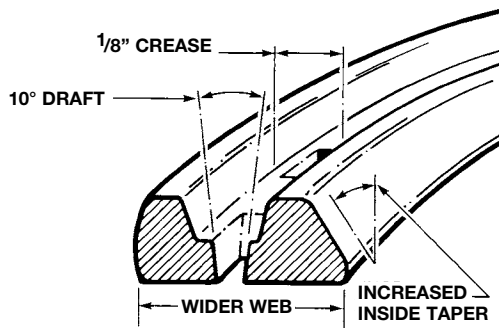

- Nail hole pattern allows more accurate nail placement
- Wide web for increased bearing surface and hoof wall support
- Full 1/8" wide crease permits deep seating of nail head in counter sink without hang-up on crease walls
- Increased inside shoe taper provides added relief from snow and clay build-up
- Precision spaced and punched nail holes
- Lightweight for reduced fatigue
- 10° crease draft gives more control over slant when following draft of foot and hoof
- Longer creases for improved traction

## Classic Plain

Size/Cat. No.	UPC No.	Length (Inches)	Width (Inches)	Approx. Wgt. Each (oz.)	Pairs Per Box	Box Weight (Lbs.)
DC000B	037103237132	4 13/32	4	6.7	20	17
DC00B	037103237149	4 23/32	4 9/32	7.7	20	20
DC0B	037103237156	4 15/16	4 5/8	8.7	20	22
DC1B	037103237163	5 9/32	4 13/16	10.0	20	24
DC2B	037103237170	5 5/8	5 1/8	11.1	10	14



DC000B

## Classic Heeled

Size/Cat. No.	UPC No.	Length (Inches)	Width (Inches)	Approx. Wgt. Each (oz.)	Pairs Per Box	Box Weight (Lbs.)
DC000HB	037103237187	4 13/32	4	6.9	20	18
DC00HB	037103237194	4 23/32	4 9/32	8.0	20	20
DC0HB	037103237200	4 15/16	4 5/8	9.1	20	24
DC1HB	037103237217	5 9/32	4 13/16	10.5	10	13
DC2HB	037103237224	5 5/8	5 1/8	11.8	10	16



DC000HB

## Classic Toed and Heeled

Size/Cat. No.	UPC No.	Length (Inches)	Width (Inches)	Approx. Wgt. Each (oz.)	Pairs Per Box	Box Weight (Lbs.)
DC00THB	037103237231	4 23/32	4 9/32	8.3	20	21
DC0THB	037103237248	4 15/16	4 5/8	9.5	20	26
DC1THB	037103237255	5 9/32	4 13/16	11.1	10	19



DC00THB

## Special Shoes

- Rounder shape than Diamond Classic shoes to give “fuller fit”
- Wider web provides more hoof wall support and protection to hoof
- Cleaner nail holes and smoother bearing surfaces for easier shoeing
- Precision hole pattern allows accurate nail placement
- Increased inside taper provides additional relief from snow and clay build-up
- Easily worked cold to fit either front or hind hooves

## Special Plain

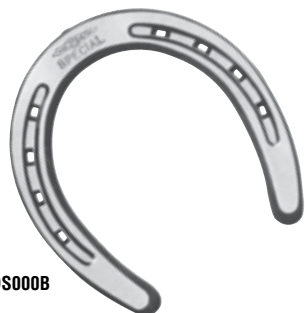

DS000B

Size/Cat. No.	UPC No.	Length (Inches)	Width (Inches)	Approx. Wgt. Each (oz.)	Pairs Per Box	Box Weight (Lbs.)
DS000B	037103237460	4 7/16	4 1/16	7.4	20	18
DS00B	037103237477	4 3/4	4 3/8	8.3	20	21
DS0B	037103237484	5	4 11/16	9.1	20	24
DS1B	037103237491	5 9/32	4 15/16	10.5	10	14
DS2B	037103237507	5 5/8	5 3/16	12.5	10	16
DS4B	037103237514	6 5/8	6 1/16	18.2	10	23
DS5B	037103237521	7 1/4	6 1/2	22.2	10	28

## Bronco Shoes

- Choice of three popular, ready-to-nail patterns
- Diamond heel and toe calks are forged—not welded
- Perfectly balanced and accurately shaped to fit average horse’s foot without alteration
- Nail hole pattern allows more accurate nail placement
- Correctly tapered nail holes are precision punched and spaced
- Designed to fit both front and hind feet
- Inside taper reduces snow and clay build-up on bottom of horse’s foot

## Plain Bronco



000PLAINB

Size/Cat. No.	UPC No.	Length (Inches)	Width (Inches)	Approx. Wgt. Each (oz.)	Pairs Per Box	Box Weight (Lbs.)
000PLAINB	037103237262	4 13/32	3 5/8	7.1	20	18
00PLAINB	037103237279	4 23/32	4 9/32	8.7	20	22
0PLAINB	037103237286	4 15/16	4 5/8	9.5	20	24
1PLAINB	037103237293	5 9/32	4 13/16	11.1	10	14
2PLAINB	037103237309	5 5/8	5 1/8	13.3	10	17

## Heeled Bronco



000HB

Size/Cat. No.	UPC No.	Length (Inches)	Width (Inches)	Approx. Wgt. Each (oz.)	Pairs Per Box	Box Weight (Lbs.)
000HB	037103237316	4 13/32	3 5/8	7.4	20	19
00HB	037103237323	4 23/32	4 9/32	9.1	20	23
0HB	037103237330	4 15/16	4 5/8	10.0	20	26
1HB	037103237347	5 9/32	4 13/16	11.8	10	15
2HB	037103237354	5 5/8	5 1/8	14.3	10	21
4HB	037103237361	6 5/8	6	22.2	10	29

## Toed and Heeled Bronco

Size/Cat. No.	UPC No.	Length (Inches)	Width (Inches)	Approx. Wgt. Each (oz.)	Pairs Per Box	Box Weight (Lbs.)
00THB	037103237378	4 23/32	4 9/32	9.5	20	24
0THB	037103237385	4 15/16	4 5/8	10.5	20	26
1THB	037103237392	5 9/32	4 13/16	12.5	10	16
2THB	037103237408	5 5/8	5 1/8	15.4	10	19
3THB	037103237415	6 5/32	5 9/16	20.0	10	25
4THB	037103237422	6 5/8	6	25.0	10	29



00THB

## Specialty Shoes - Hind

- Designed to fit the majority of hind feet with little or no modification
- Nail holes right where they need to be
- Beveled for sole relief
- Clipped heels to minimize buildup, but still offer maximum support

Size/Cat. No.	UPC No.	Length (Inches)	Width (Inches)	Approx. Wgt. Each (oz.)	Pairs Per Box	Box Weight (Lbs.)
00HINDB	037103237439	4 3/4	4 3/8	8.5	20	20
0HINDB	037103237446	5 1/8	4 3/4	9.5	20	24
1HINDB	037103237453	5 3/8	4 7/8	10.5	10	14



1HINDB

## Specialty Shoes - Pony

- Forged from special steel (like the regular horseshoe) to give long wear
- Six properly spaced nail holes fit the average pony hoof

Size/Cat. No.	UPC No.	Length (Inches)	Width (Inches)	Approx. Wgt. Each (oz.)	Pairs Per Box	Box Weight (Lbs.)
0PONYB	037103237576	3 3/4	3 5/16	5.0	40	24
1PONYB	037103237583	4 1/16	3 7/16	5.3	40	26

NOTE: For No. 2 Pony shoe, use Diamond® Cat. No. 000PLAIN Bronco horseshoe.

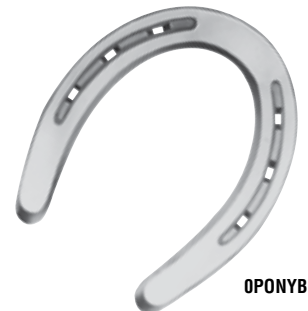

0PONYB

## Specialty Shoes - Rim

- Popular choice for cutting, roping, barrel racing, pleasure, polo, or jumping
- Deep, self-cleaning crease designed for positive grip

Size/Cat. No.	UPC No.	Length (Inches)	Width (Inches)	Approx. Wgt. Each (oz.)	Pairs Per Box	Box Weight (Lbs.)
00RIMB	037103237538	4 1/2	4 1/8	8.8	20	20
0RIMB	037103237545	4 3/4	4 9/32	9.0	20	22
1RIMB	037103237552	5	4 5/8	10.9	20	24
2RIMB	037103237569	5 3/8	4 25/32	11.3	20	25



00RIMB

## Specialty Shoes - Toe Weights



1TWB

- Designed for Tennessee walking horses or other breeds that require extra weights
- Forged with countersunk nail holes and weight at the toe
- Sizes 1 and 2 have three nail holes on each side, size 3 has four

Size/Cat. No.	UPC No.	Length (Inches)	Width (Inches)	Thickness (Inches)	Approx. Wgt. Each (oz.)	Pairs Per Box	Box Weight (Lbs.)
1TWB	037103237644	5 1/4	4 1/2	1 1/4 x 3/8	15.0	10	19
2TWB	037103237668	5 3/4	4 7/8	1 3/8 x 3/8	18.0	10	23
3TWB	037103237675	6 1/8	5 1/4	1 3/8 x 7/16	20.3	10	25

## Clipped Shoes



D2HCB



- Uniquely ground and brushed on both sides, like all Diamond shoes, for the cleanest nail holes
- Rounder shape gives fuller fit so less modification is needed
- Helps stabilize shoe to foot

Size/Cat. No.	UPC No.	Length (Inches)	Width (Inches)	Approx. Wgt. Each (oz.)	Pairs Per Box	Box Weight (Lbs.)
<b>Clipped Shoes - Front</b>						
D00FCB	037103237705	4 1/4	4 9/16	9.0	20	23
D0FCB	037103237729	5	4 11/16	10.0	20	25
D1FCB	037103237743	5 1/4	4 15/16	11.0	20	28
D2FCB	037103237767	5 1/2	5	12.0	20	30
<b>Clipped Shoes - Hind</b>						
D00HCB	037103237712	4 3/8	4 1/2	9.0	20	23
D0HCB	037103237736	5 1/8	4 3/4	10.0	20	25
D1HCB	037103237750	5 3/8	4 7/8	11.0	20	28
D2HCB	037103237774	5 5/8	5 1/4	12.0	20	30

## Competitor Shoes



0FBDCB



0HBDCB

- Full crease for maximum traction and stability
- Straight heel cut 5/16" thick for needed support
- Forged sole relief
- Built-in roll toe allows horse to "Break Over" where they want
- Wide web offers more protection for performance and competitive horses
- Inside bevel for better traction, confidence, and helps prevent build-up
- Crease depth perfect for locking in nail heads and added traction
- Clean nail holes with ideal placement

Size/Cat. No.	UPC No.	Length (Inches)	Width (Inches)	Approx. Wgt. Each (oz.)	Pairs Per Box	Box Weight (Lbs.)
<b>Competitor Shoes - Front</b>						
0FBDCB	037103237606	5	4 3/4	9.8	20	25
1FBDCB	037103237620	5 1/4	4 7/8	10.4	20	26
2FBDCB	037103237651	5 3/4	5 3/8	12.5	10	16
<b>Competitor Shoes - Hind</b>						
00HBDCB	037103237590	4 3/4	4 3/8	8.7	20	22
0HBDCB	037103237613	5 1/8	4 3/4	9.8	20	25
1HBDCB	037103237637	5 3/8	4 7/8	10.4	20	26



## Specialty Shoes - Draft

- Forged, punched and creased for easy application
- Reworkable to form smaller sizes
- Heels can be turned up or cut off
- Beveled on inside for relief of snow or clay

Size/Cat. No.	UPC No.	Length (Inches)	Width (Inches)	Thickness (Inches)	Approx. Wgt. Each (oz.)	Pairs Per Box	Box Weight Lbs.
6DRAFTB	037103237682	9 1/2	6 1/2	1/2	41	10	51
8DRAFTB	037103237699	9 7/8	7 1/8	1/2	48	10	60



6DRAFTB

## Diamond® Plastic Hoof Pads

- For use between shoe and hoof
- Molded from special, natural color polyurethane
- Long wearing, non-absorbent and not affected by weather or moisture
- Can be reused and is easily trimmed to fit any size hoof
- Size is 6 1/2" x 6" x 1/8" thick

Cat No.	UPC No.	Description	Shipping Wgt. Per Box	Packed Per Box
66	043127102264	Hoof Pad	5 lbs.	10 Pr.



## Diamond® Horseshoe Nails

- Manufactured from the highest quality steel with a closely controlled rolling process that produces precision nails with a high tensile strength
- Uniformly tempered to provide optimum elasticity while preserving material strength for consistent and easy driving
- Slim, sleek shank drives easier and safer
- Sharp beveled points for easy hoof wall exit
- Proper stiffness for straight accurate driving without bending, while clinching easily after wall exit for firm holding
- Nails are packaged in an attractive, durable plastic container with a replaceable sliding lid for easy and secure storage



Catalog Number	UPC Number	Size & Description	Nails Per Box	Boxes Per Case	Nails Per Pound	Pounds Per Case (Approx)
D412CH1	037103228352	4 1/2 City Head Nail	100	24	204	16.0
D412RACE1	037103228383	4 1/2 Race Head Nail	100	24	217	16.0
D5CC2	037103228376	5 City Combo Head Nail	250	12	161	21.0
D5CH1	037103228291	5 City Head Nail	100	24	172	18.0
D5CH2	037103228307	5 City Head Nail	250	12	172	21.0
D5CS1	037103228321	5 City Slim Head Nail	100	24	179	18.0
D5CS2	037103228314	5 City Slim Head Nail	250	12	179	20.0
D5RH1	037103228369	5 Regular Head Nail	100	24	133	19.0
D6CH1	037103228338	6 City Head Nail	100	24	128	21.0
D6RH1	037103228390	6 Regular Head Nail	100	24	101	24.0

## Diamond® Hoof Nippers



FN12

- Professional quality
- Precision manufactured from special alloy steel with button rivet

Cat. No.	UPC No.	Size (Inches)	Packed Per Box	Weight Each
FN12	043127101717	12	1	1 lb. 6 oz.
FN15	043127101731	15	1	1 lb. 12 oz.

## Diamond® Economy Hoof Nippers



14DN

- Economy model
- Forged from high quality steel with heat-treated jaws and handles
- Sharp cutting edges are hardened, honed and flush ground
- Chrome plated with polished head and plastic coated handles

Cat. No.	UPC No.	Size (Inches)	Packed Per Box	Weight Each
14DN	037103213747	14	1	2 lbs.

## Diamond® Nail Cutting Nippers



N10

- Improved beveled cutting angle provides more strength
- 10" handle for increased leverage
- Developed specifically for cutting horseshoe nails
- Full polished head with wide throat clearance engineered to allow close cutting

Cat. No.	UPC No.	Size (Inches)	Packed Per Box	Weight Each
N10	043127101755	10	1	8 oz.

## Crescent® Nail Nippers



728CVN

- Designed with wide throat clearance and high handle leverage
- Jaws angled for ease in cutting close to flat surfaces
- Forged from high strength alloy steel for increased jaw and handle strength

Cat. No.	UPC No.	Size (Inches)	Packed Per Box	Weight Each
728CVN *	037103213112	8	6	14 oz.
729CVN *	037103213143	9	6	16 oz.

\* Plastic grips and carded

## Diamond® Combination Shoe Puller / Spreader

- Has exclusive pattern with sharp teeth on outside edges for ease in spreading most shoe sizes and styles
- Can also be used for cutting nails
- Round knobs on handle ends make selection easy
- Button rivet construction



SP12D

Cat. No.	UPC No.	Size (Inches)	Packed Per Box	Weight Each
SP12D	043127066993	12	1	1 lb. 8 oz.

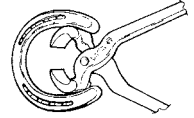
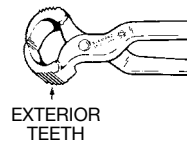

## Diamond® Crease Nail Puller

- For removal of nails from crease of shoes that have been on horse for some time
- An essential tool for removal of misdriven nails from new shoes
- Precision forged from high quality tool steel for long life
- Button rivet construction with polished head



NP12

Cat. No.	UPC No.	Size (Inches)	Packed Per Box	Weight Each
NP12	043127101816	12	1	1 lb.

## Diamond® Farrier Tongs

- Manufactured from special low carbon steel for lasting strength
- Will not become brittle when quenched in water
- Ideal for handling average size shoes



FT15

Cat. No.	UPC No.	Size (Inches)	Packed Per Box	Weight Each
FT15	043127101793	15	5	1 lb.

## Diamond® Horse Rasps

- Superior performance in both wet and dry conditions
- Resists clogging due to the angled tooth face
- Rasp teeth on one side, file teeth on other side, single cut on edges
- Rasp side allows for aggressive, but controlled hoof removal
- File side produces a consistent smooth finish
- Outlaw Rasp is less aggressive, but extremely durable for long life.



HR15

Cat. No.	UPC No.	Description	Packed Per Box
HR15	037103206343	14" Outlaw Horse Rasp	6
HR14N	037103219510	14" Horse Rasp/File	6



HR14N

## Nicholson® Horse Rasps



18130N



18155N



18035N



18057N

- All have rasp teeth one side and file teeth on other side – single cut on edges
- 18035N & 18057N have rasp teeth cut 5 teeth per row
- 18130N & 18155N have rasp teeth cut 6 teeth per row
- 18130N boasts the Nicholson® unique Magicut® file pattern of narrow chip breakers created by steep and angled serrations

Cat. No.	UPC No.	Description	Packed Per Box
18130N	037103219534	14" Plater's Magicut Rasp/File	6
18155N	037103219558	14" Farrier's Handy Rasp/File	5
18035N	037103219466	12" Tanged Horse Rasp/File	6
18057N	037103219473	14" Tanged Horse Rasp/File	6

## Nicholson® Horse Rasp - 1/2 File



17873N

- Plain horse rasps are double ended; rasp teeth on one side, file teeth on other
- Many farriers prefer this rasp for shoeing racetrack and riding horses

Cat. No.	UPC No.	Description	Packed Per Box
17873N	037103219459	12" Double-ended Horse Rasp/File	6
17903N	037103217998	14" Double-ended Horse Rasp/File	6

## Nicholson® 4-in-Hand® Rasp/File



18962N

- Four files in one - File section and a rasp section on flat side - file section and rasp section on half round side

Cat. No.	UPC No.	Description	Packed Per Box
18962N	037103219794	10" 4-in-Hand Rasp/File	6

## Nicholson® Half Round Horseshoe File



05190N

- Half round shape to work inside and outside the shoe

Cat. No.	UPC No.	Description	Packed Per Box
05190N	037103218940	14" Half Round Pipeliner File	6

### Nicholson® Handy File

- One side is single cut for smoothing surfaces
- Reverse side is double cut for general filing and rapid stock removal
- Cut edge - 1 safe edge



06601

Cat. No.	UPC No.	Description	Packed Per Box
06601	037103066015	8" Handy File	6

### Nicholson® Accessories

- Handles for tanged rasps and files
- Drive-on and screw-on styles available
- # 21458 file cleaning card for general cleaning of file teeth and for improving the life of any rasp or file



TG4N

Cat. No.	UPC No.	Description	Packed Per Box
21470N	037103221346	Farrier Rasp Handle, Size 000	12
TG4N	037103227232	Screw-on Handle for 14" Rasp	12
21458	037103214584	10" File & Rasp Cleaner	10
21516	037103215161	Plastic Screw-on Handle	12



21458



21516

### Diamond® Hoof Knives

- High quality steel blades
- Two blade widths—# 271 is narrow; # 280 is wide
- Choice of right or left hand blades. *(Specify when ordering)*

Cat. No.	UPC No.	Size (Inches)	Packed Per Box	Weight Each
271R	043127102097	8	6	3 oz.
271L	043127102103	8	6	3 oz.
280R	043127102110	8	6	3.5 oz.
280L	043127102127	8	6	3.5 oz.



271



280

Note: Suffix "R" indicates right hand blade and "L" left hand.

### Nicholson® Hoof Knife Sharpening Steel

- Sharpening steel is designed specially to hone the edge of Hoof Knives and similar tools



10627

Cat. No.	UPC No.	Description	Packed Per Box
10627	037103191274	Hoof Knife Sharpening Steel	6

## Diamond® Clinchers



- Four models forged from high quality steel with button rivet
- **Farrier Clincher (FC12)**—designed to roll over high and low nails. Downward push with rolling action clinches nail  
NOTE: Tool should not be squeezed when clinching nail
- **Saddle Horse Clincher (HC12)**—for use on larger nails in saddle horse hoofs
- **Gooseneck Clincher (PC12)**—turns heads of smaller nails when shoeing ponies and race horses

Cat. No.	UPC No.	Size (Inches)	Packed Per Box	Weight Each
FC12	043127101823	12	1	1 lb.
HC12	043127101830	12	1	1 lb. 1 oz.
PC12	043127101847	12	1	1 lb. 2 oz.

## Diamond® Clinch Cutter



- High quality steel forging
- Beveled on outside edge only. Flush inside edge allows close cutting
- An all purpose tool with one end designed for cutting and the other for pritchel

Cat. No.	UPC No.	Length (Inches)	Width (Inches)	Packed Per Box	Weight Each
C7	043127102042	6	2 3/4	6	12 oz.

## Diamond® Clinch Block



- Solid steel for clinching and seating nails

Cat. No.	UPC No.	Size (Inches)	Packed Per Box	Weight Each
CB4	043127102080	4	6	10 lb. 6 oz.

## Diamond® Pritchel



- Manufactured from high quality 5/8" tool steel
- Clears shoe nail holes
- New flat design

Cat. No.	UPC No.	Size (Inches)	Packed Per Box	Weight Each
P12D	043127102172	12	12	14 oz.

### Diamond® Fence Tool

- For wood and steel posts on ranch or farm
- Heavy-duty lockjoint construction with oval faced jaws
- Starting and pulling point on one jaw with corrugated hammer head on the other
- Front pulls staples, lifts lugs, and splices wires— wire stretcher located behind joint
- Handles green plastic coated



DFT10

Cat. No.	UPC No.	Size (Inches)	Packed Per Box	Weight Each
DFT10	037103197351	10-5/8	10	1 lb. 8 oz.

### Crescent® Fence Tools

- Designed for construction and maintenance of wire fencing with or wood and steel posts on ranch or farm
- Heavy-duty lockjoint construction with hardened and durable cutting edges
- Made of forged alloy tool steel with polished head and gunmetal finish
- Wire cutter on each side of head cuts double strand barbed wire
- All 5 SKUs are carded

#### Fence Tool

- Starting and pulling point on one jaw with corrugated hammer head on the other
- Front pulls staples, lifts lugs, and splices wires – wire stretcher behind joint

#### Button Fence Tool

- Flat nose style with 3 wire cutters, pipe grips and teeth in extreme tip of nose



193410VN



193610CVSMN



100010VN

Cat. No.	UPC No.	Size (Inches)	Packed Per Box	Weight Each
193410VN	037103213082	10-5/16	6	1 lb. 8 oz.
193410CVN *	037103213075	10-5/16	6	1 lb. 8 oz.
193610VN	037103212955	10-7/16	6	1 lb. 10 oz.
193610CVSMN *	037103212948	10-7/16	6	1 lb. 11 oz.
100010VN	037103213051	10-1/4	6	1 lb. 4 oz.

\* Red cushion grip handles

### Crescent® Cee Tee Co.® Combination

- Slip joint pliers, slender head for balance and control
- Riveted joint construction is stronger and maintains better joint and cutting performance
- Designed for gripping/turning round objects such as pipes, rods and pins
- Curved jaws combination with machined gripping teeth and wire cutter
- Forged alloy steel construction, spring tempered for strength/durability
- Nickel chrome plated finish
- Knurled handles or red double dipped non-slip cushion handle grips



H26N

Cat. No.	UPC No.	Size (Inches)	Packed Per Box	Weight Each
H26N	037103227959	6-1/2	6	8 oz.
H28N	037103227980	8	6	9.6 oz.

**CAUTION: Always wear approved eye protection**

## Lufkin® Measuring Tapes

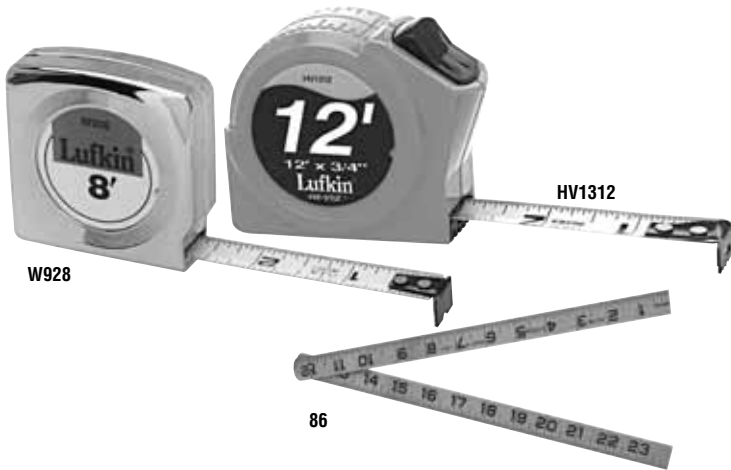

- Cat. # W928 durable chrome case helps resist extreme forging temperatures

Cat. No.	UPC No.	Description	Packed Per Box
HV1312	037103045904	3/4" x 12' Hi-viz® Pocket Tape	6
W928	037103458728	1/2" x 8' Chrome Pocket Tape	6
86	037103452825	2 ft. Steel Folding Blacksmith's Rule	12

## Wiss® Pad Cutters

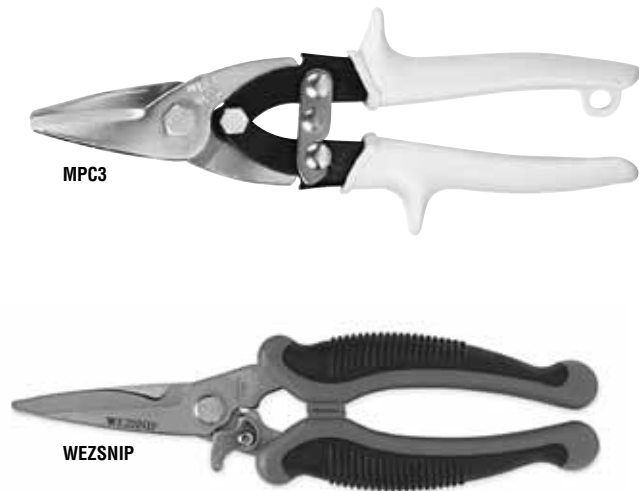

### MPC3

- Ideal for cutting plastic and leather hoof pads
- Compound action, serrated jaws, safety latch and yellow vinyl comfort grips

### WEZSNIP

- Spring-loaded blades for reduced fatigue on repeated cuts
- Soft-touch co-molded handles for maximum comfort
- 420 Stainless blades provide maximum corrosion resistance
- Wire cutter notch for easy cutting of light-gauge wire or cable
- Safety-latch locks blades closed for storage
- Heavy-duty design

Cat. No.	UPC No.	Length (Inches)	Cut Length (Inches)	Packed Per Box	Weight Each
MPC3	037103580221	9	1 3/8	6	12 oz.
WEZSNIP	037103211309	8-3/4	4	4	4.8 oz.

## Diamond® Specialty Hammers

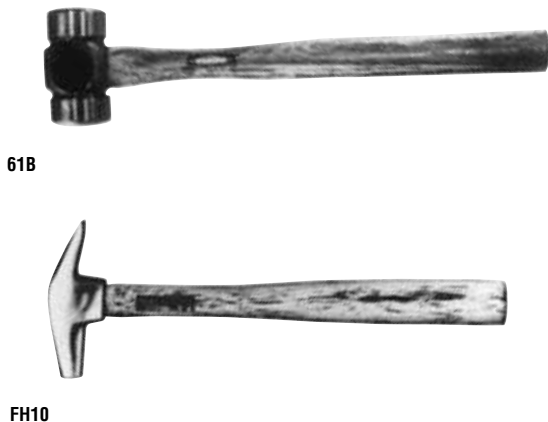

### Rounding Hammers

- Perfectly balanced; one round, crowned face, one flat
- Faces beveled to reduce possibility of chipping
- Hardwood handles

### Driving Hammers

- Forged from high quality steel
- The most useful farrier hammer available
- Hardwood handles

Cat. No.	UPC No.	Description	Packed Per Box
60	043127101861	24 oz. Rounding Hammer	4
61B	043127101892	36 oz. Rounding Hammer	4
FH10	043127101878	10 oz. Race Track Driving Hammer	6
FH14	043127066955	14 oz. Farrier Driving Hammer	6



## Plumb® Hammers

- Quality steel forgings hardened and tempered
- Black enamel finish with polished face
- Select quality hickory handle

Cat. No.	UPC No.	Description	Packed Per Box
11496	037103114969	8 oz. Ball Pein Hammer-Wooden Handle	6
11497	037103114976	12 oz. Ball Pein Hammer-Wooden Handle	6
11498	037103114983	16 oz. Ball Pein Hammer-Wooden Handle	6
11520	037103115201	24 oz. Ball Pein Hammer-Wooden Handle	6
11521	037103115218	32 oz. Ball Pein Hammer-Wooden Handle	6
11527	037103115270	2 1/2 lbs. Double Face Engineer Hammer	6
11528	037103115287	3 lbs. Double Face Engineer Hammer	6
11529NN	037103227164	4 lbs. Double Face Engineer Hammer	6
11524	037103115249	2 1/2 lbs. Blacksmith Hammer	6
11525P	037103115256	3 lbs. Blacksmith Hammer	6

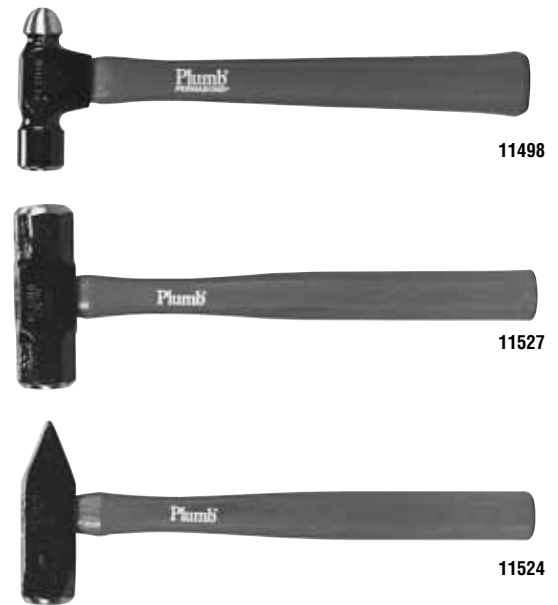

## Diamond® Farrier Tools Assortment

- Most popular farrier tools
- Unique vinyl backing with product outlines

Cat. No.	UPC No.	Description	Packed Per Box
DF3A	037103178756	Farrier Tools Display Assortment	1
DF3B	037103178749	Display Board Only - No Tools	1
<b>Contents:</b>			
14DN	037103213747	14" Hoof Nippers	2
271L	043127102103	8" Narrow Hoof Knife, Left Hand	1
280L	043127102127	8" Wide Hoof Knife, Left Hand	1
271R	043127102103	8" Narrow Hoof Knife, Right Hand	1
C7	043127102042	6" Clinch Cutter	1
FH10	043127101878	10 oz. Race Track Driving Hammer	1
FH14	043127066955	14 oz. Farrier Driving Hammer	1
FN15	043127101731	15" Farrier Nippers	1
HC12	043127101830	12" Clincher	1
HR14N	037103219510	14" Horse Rasp/File	1
N10	043127101755	10" Nail Cutting Nippers	1
NP12	043127101816	12" Crease Nail Puller	1
SP12D	043127066993	12" Combination Shoe Puller/Spreader	1
DF3B	037103178749	Display Board Only	1



**INDEX**

Cat. No.	Page	Cat. No.	Page	Cat. No.	Page	Cat. No.	Page
000HB	4	100010VN	13	C7	12, 15	DS000B	4
000PLAINB	4	193410VN	13	CB4	12	DS1B	4
00HB	4	193610CVSMN	13	D00FCB	6	DS2B	4
00HBDCB	6	193610VN	13	D00HCB	6	DS4B	4
00HINDB	5	1FBDCB	6	D0FCB	6	DS5B	4
00PLAINB	4	1HB	4	D0HCB	6	FC12	12
00RIMB	5	1HBDCB	6	D1FCB	6	FH10	14, 15
00THB	5	1HINDB	5	D1HCB	6	FH14	14, 15
05190N	10	1PLAINB	4	D2FCB	6	FN12	8
06601	11	1PONYB	5	D2HCB	6	FN15	8, 15
0FBDCB	6	1RIMB	5	D412CH1	7	FT15	9
0HB	4	1THB	5	D412RACE1	7	H26N	13
0HBDCB	6	1TWB	6	D5CC2	7	H28N	13
0HINDB	5	21458	11	D5CH1	7	HC12	12, 15
0PLAINB	4	21470N	11	D5CH2	7	HR14N	9, 15
0PONYB	5	21516	11	D5CS1	7	HR15	9
0RIMB	5	271L	11, 15	D5CS2	7	HV1312	14
0THB	5	271R	11, 15	D5RH1	7	MPC3	14
10627	11	280L	11, 15	D6CH1	7	N10	8, 15
11496	15	280R	11	D6RH1	7	NP12	9, 15
11497	15	2FBDCB	6	DC0B	3	P12D	12
11498	15	2HB	4	DC00B	3	PC12	12
11520	15	2PLAINB	4	DC000B	3	SP12D	9, 15
11521	15	2RIMB	5	DC000HB	3	TG4N	11
11524	15	2THB	5	DC00HB	3	W928	14
11525P	15	2TWB	6	DC00THB	3	WEZSNIP	14
11527	15	3THB	5	DC0HB	3		
11528	15	3TWB	6	DC0THB	3		
11529NN	15	4HB	4	DC1B	3		
14DN	8, 15	4THB	5	DC1HB	3		
17873N	10	60	14	DC1THB	3		
17903N	10	61B	14	DC2B	3		
18035N	10	66	7	DC2HB	3		
18057N	10	6DRAFT	7	DF3A	15		
18130N	10	728CVN	8	DF3B	15		
18155N	10	729CVN	8	DFT10	13		
18962N	10	86	14	DS0B	4		
193410CVN	13	8DRAFTB	7	DS00B	4		

# These nails are Diamond Tough.



Diamond nails are made to work perfectly in the toughest conditions. Specially tapered with a smooth-as-silk finish, they drive straight every time.

Diamond is the only farrier line that has it all – shoes, nails, tools, and rasps – plus a tradition of providing professional quality and exceptional value for over 100 years.

Diamond ... the hardest-working brand in the farrier business.



[www.diamondfarrier.com](http://www.diamondfarrier.com)

**Apex Tool Group**  
**World Headquarters**  
14600 York Road, Suite A  
Sparks, MD 21152  
Tel: 919-387-0099  
Fax: 919-387-2614

**Customer Service U.S.**  
**TELEPHONE:**  
North ..... 866 907 9706  
South ..... 866 907 9706  
Midwest ..... 866 907 9716  
West/SW ..... 866 907 9716  
Hardware ..... 919-362-1670  
**FAX:**  
North ..... 800-854-5137  
South ..... 800-854-5139  
Midwest ..... 800-854-5138  
West/SW ..... 800-546-7312  
Hardware ..... 877-387-0415  
Export ..... 919-387-2402

**Customer Service Canada**  
Phone ..... 705-728-3888  
Fax ..... 800-403-8665



14600 York Road, Suite A  
Sparks, MD 21152  
[www.apextoolgroup.com](http://www.apextoolgroup.com)