

DL400

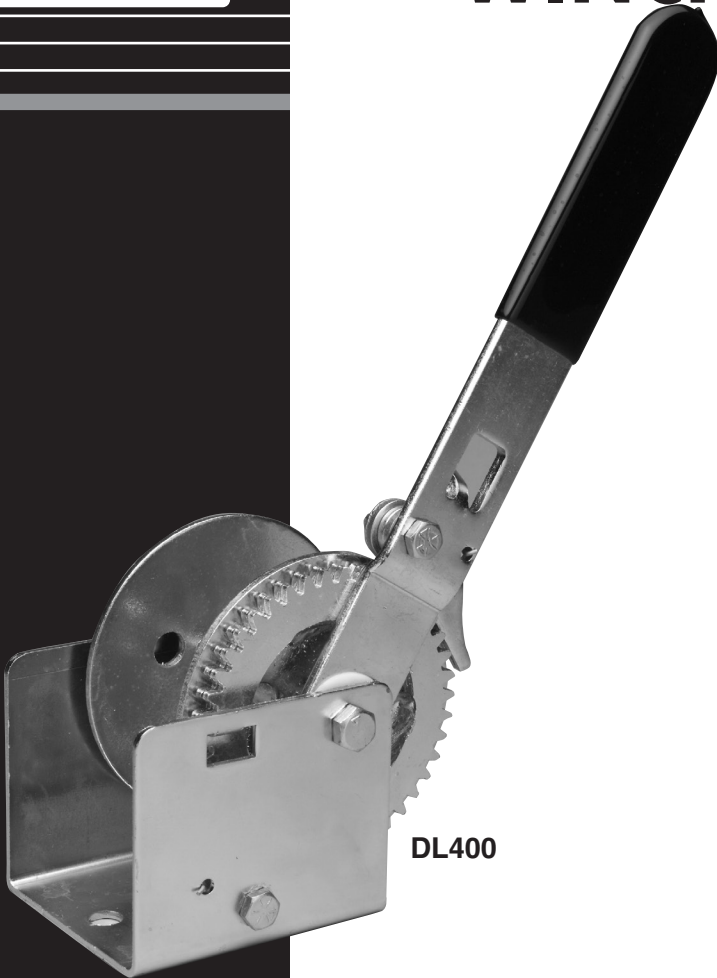

PULLING WINCH



DL400

A Dependable Company Since 1886

DUTTON-LAINSON COMPANY

Hastings, NE 68902 U.S.A • Tel 402-462-4141 • Fax 402-460-4612
E-mail dlsales@dutton-lainson.com • Web Site www.dutton-lainson.com

MADE IN
USA

ISO 9001 Certified Q.M.S.

⚠ WARNING READ INSTRUCTIONS CAREFULLY BEFORE ATTEMPTING TO INSTALL, OPERATE OR SERVICE THIS WINCH. FAILURE TO COMPLY WITH INSTRUCTIONS COULD RESULT IN SERIOUS OR FATAL INJURY. RETAIN THESE INSTRUCTIONS FOR FUTURE REFERENCE.



IMPORTANT SAFETY INFORMATION

- This winch is built for multi-purpose hauling and pulling operations. It is not recommended for lifting applications. For lifting, use a self-locking winch. DL winches are not to be used as hoists for lifting, supporting or transporting people, or for loads over areas where people could be present.
- Respect this winch. High forces are created when using a winch, creating potential safety hazards. It should be operated and maintained in accordance with instructions. Never allow children or anyone who is not familiar with the operation of the winch to use it.
- When releasing a load with this winch, use extreme caution and maintain a firm grip on the winch handle at all times.
- Check for proper ratchet operation on each use of the winch. Do not use if damaged. Seek immediate repairs.
- Never use the winch handle as a convenient handle for pulling or maneuvering the entire trailer or other equipment. Never pull on the winch handle against a locked ratchet.
- Never exceed rated capacity. Excess load may cause premature failure and could result in serious personal injury. This winch is rated with three layers of line on the hub. Using more layers of line or a large hub increases the load on the winch.
- Never apply load on winch with cable or rope fully extended. Keep at least three full turns of cable or rope on the reel.
- Secure load properly. When winching operation is complete, do not depend on winch to support load.
- Operate with hand power only. This winch should not be operated with a motor of any kind. If the winch cannot be cranked easily with one hand, it is probably over-loaded.

WINCH MOUNTING AND STRAP OR CABLE ATTACHMENT

— If steel cable is used, SAE Standard J1853 requires winch line breaking strength to be at least 1-1/2 times winch rating (breaking strength of hook must be 1-1/2 times breaking strength of line) and drum hub diameter must be 8 times cable diameter. 5/64" cable meets these requirements.

Attach cable or rope by method described in sketch shown. If nylon strap is used, it should have a loop sewn in one end and be attached using a 1/4" x 2-3/4" long bolt and locknut. Use a locknut, not a nut and lockwasher. Insert bolt through slots in both reel sideplates so that nut is on gear side. Tighten only until snug with bolt in bottom of slot next to reel hub.

The DL400 can be either mounted directly onto a flat, rigid mounting surface (ex. - trailer winch stand) using (2) 3/8" bolts, washers, and lockwashers (figure 1) or used with the No.6386 ball adaptor plate (figure 2).

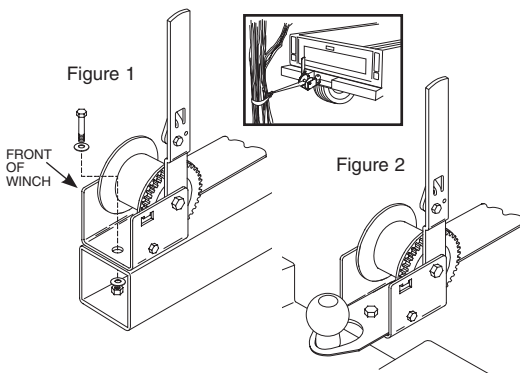

OPERATING INSTRUCTIONS — Wind line on winch reel by moving handle back and forth with both ratchet pawls engaged. Both ratchets should produce a loud, sharp, clicking noise.

To unwind or reel out line, with a load on the winch, first disengage ratchet pawl on handle and move handle clockwise (see figure 3). Re-engage handle ratchet pawl and move handle counter-clockwise one click. With a firm grip on the handle, move it clockwise slightly to relieve tension on ratchet pawl attached to base. Disengage base ratchet pawl and move handle counter-clockwise to stop (approximately 4" of line travel) (see figure 4). Re-engage base ratchet pawl, move handle clockwise one click and again disengage handle ratchet pawl and move handle clockwise to the stop and repeat sequence.

To 'freewheel' line off with no load on the winch, disengage both ratchet pawls which allows line to be pulled out freely.

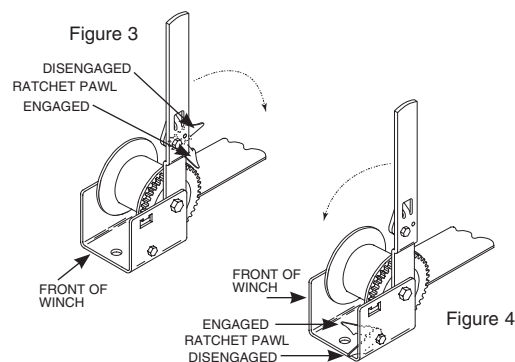

WINCH MAINTENANCE — This winch has been fully lubricated at the factory; but, for continued smooth performance and increased life, occasional greasing of reel shaft is recommended.

Keep winch in good working order. Damaged or severely-worn parts create unnecessary dangers and could result in personal injury or property damage.



NOT FOR THE MOVEMENT OF HUMAN BEINGS

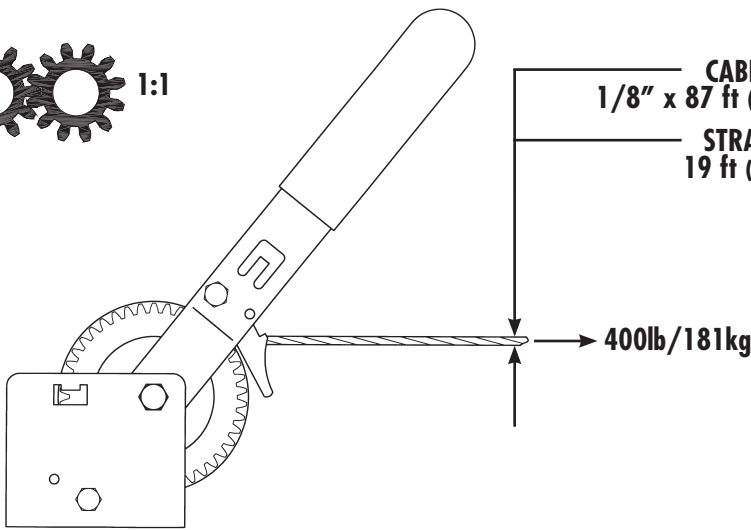

CABLE
1/8" x 87 ft (3 mm x 27 m)

STRAP
19 ft (6 m)

400lb/181kg



ENGLISH – DECLARATION OF CONFORMITY - Dutton-Lainson Company, Hastings, NE 68902-0729 U.S.A. manufactures and declares that the winch identified above fulfills all relevant provisions of the Directive 2006/42/EC. The technical file may be obtained from the persons listed below.

DEUTSCH – KONFORMITÄTSERKLÄRUNG - Dutton-Lainson Company, Hastings, NE 68902-0729, USA, der Hersteller der Winde, erklärt, dass die oben angegebene Winde alle relevanten Bestimmungen der Richtlinie 2006/42/EG erfüllt. Die technischen Unterlagen sind bei den nachfolgend aufgeführten Personen erhältlich.

ITALIANO – DICHIARAZIONE DI CONFORMITÀ - Il fabbricante, Dutton-Lainson Company, Hastings, NE 68902-0729 USA, dichiara che il verricello di cui sopra è conforme alle disposizioni della direttiva 2006/42/CE. Il fascicolo tecnico può essere richiesto agli individui indicati qui di seguito..

PORTUGUÊS – DECLARAÇÃO DE CONFORMIDADE - A empresa Dutton-Lainson Company, Hastings, NE 68902-0729, nos E.U.A., fabrica o guincho acima identificado e declara que este cumpre todas as provisões relevantes da Directiva 2006/42/CE. Poderá obter o processo técnico junto das pessoas indicadas abaixo.

ESPAÑOL – DECLARACION DE HOMOLOGACION - Dutton-Lainson Company, de Hastings, NE 68902-0729 EE.UU., fabrica y declara que el cabrestante arriba identificado satisface todas las provisiones pertinentes de la directriz 2006/42/CE. El archivo técnico puede obtenerse de las personas mencionadas a continuación..

SVENSKA – FÖRSÄKRAN OM ÖVERENSSTÄMMELSE - Dutton-Lainson Company, Hastings, Nebraska 68902-0729 U.S.A, tillverkar och försäkrar att denna vinsch överensstämmer med alla tillämpliga bestämmelser i Direktiv 2006/42/EC. Den tekniska filen kan erhållas från de personer, som upptas nedan.

Hastings, NE USA
December 12, 2018

Director of Engineering
Dutton-Lainson Company

DANSK – OVERENSSTEMMELSEERKLÆRING - Dutton-Lainson Company, Hastings, NE 68902-0729 USA fremstiller og erklærer, at skraldespillet identificeret ovenfor er i overensstemmelse med alle relevante krav i direktiv 2006/42/EU. Den tekniske fil kan rekvireres gennem de nedennævnte personer.

SUOMI – VAATIMUSTENMUKAISUUSVAKUUTUS - Dutton-Lainson Company, osoite Hastings, NE 68902-0729 U.S.A, vakuuttaa tämän vintturin valmistajana, että tämä vintturi noudattaa direktiivin 2006/42/EY olennaisia määräyksiä. Tekniset tiedot on saatavissa alla ilmoitetuilta henkilöiltä.

NORSK – SAMSVARERKLÆRING - Dutton-Lainson Company, Hastings, NE 68902-0729 U.S.A. produserer og erklærer at vinsjen angitt ovenfor oppfyller alle relevante krav i direktivet 2006/42/EC. Den tekniske filen kan skaffes fra personene som er opplistet nedenfor.

NEDERLANDS – VERKLARING VAN OVEREENSTEMMING - Dutton-Lainson Company, Hastings, NE 68902-0729 VS, fabrikant, verklaart dat de bovengenoemde lier voldoet aan alle betreffende bepalingen van richtlijn 2006/42/EC. Het technische bestand kan bij de hierna vermelde personen worden aangevraagd.

FRANÇAIS – DÉCLARATION DE CONFORMITÉ - Dutton-Lainson Company, Hastings, NE 68902-0729 U.S.A. construit le treuil mentionné ci-dessus et déclare qu'il répond à toutes les dispositions applicables de la Directive 2006/42/CE. Le dossier technique peut être obtenu auprès des personnes indiquées ci-dessous.

ΕΛΛΗΝΙΚΑ – ΔΗΛΩΣΗ ΣΥΜΜΟΡΦΩΣΗΣ - Η Dutton-Lainson Company, Hastings, NE 68902-0729 U.S.A. κατασκευάζει και δηλώνει ότι το βαρούλκο που καθορίζεται παραπάνω πληροί όλες τις σχετικές διατάξεις της Οδηγίας 2006/42/ΕΚ. Ο τεχνικός φάκελος είναι διαθέσιμος από τα άτομα τα οποία αναγράφονται παρακάτω.

Jack Singleton
Bainbridge International Limited
Unit 8, Flanders Park, Flanders Road, Hedge End
Southampton, Hampshire, SO30 2FZ



DL400

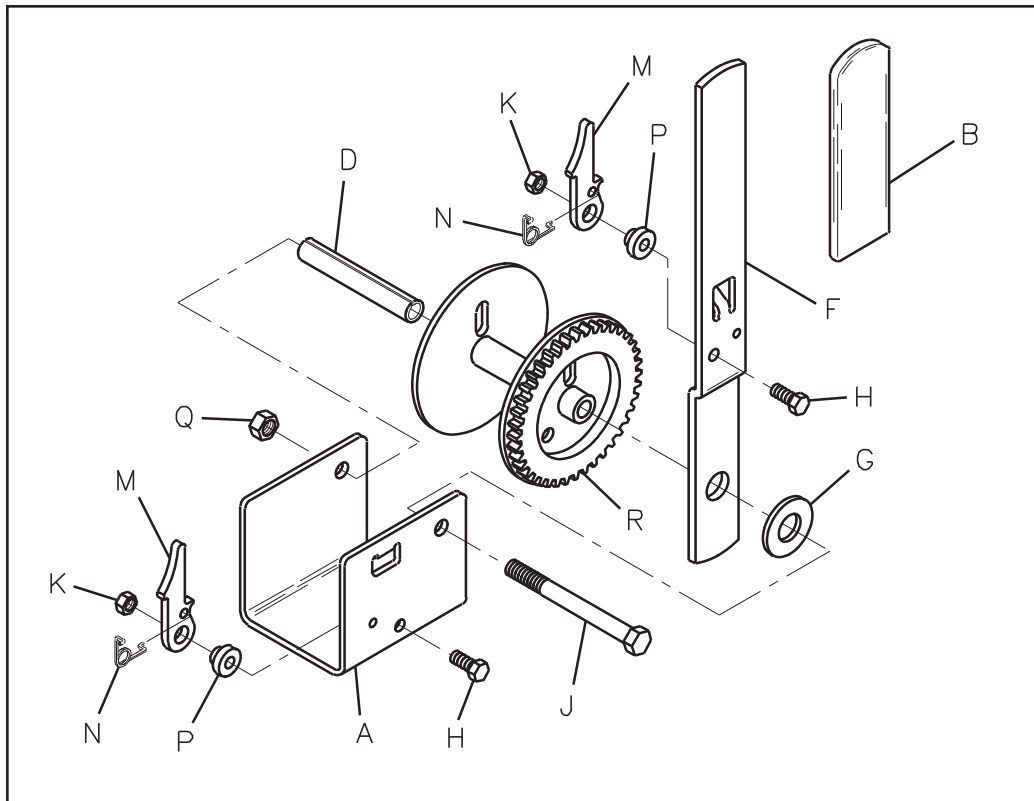

| Ref. | Description | Part No. |
|------|--------------------|----------|
| A | Winch Base | 404714 |
| B | Handle Grip | 206139 |
| D | Reel Spacer | 206129 |
| F | Handle | 404716 |
| G | Nylon Washer | 206130 |
| H | Ratchet Bolt (2) | 205004 |
| J | Reel Shaft | 205315 |
| K | Locknut (2) | 205168 |
| M | Ratchet Pawl (2) | 404035 |
| N | Ratchet Spring (2) | 204116 |
| P | Ratchet Spacer (2) | 404785 |
| Q | Locknut | 205316 |
| R | Winch Reel | 304778 |

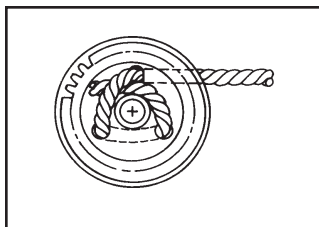

To order replacement parts:

Dutton-Lainson Company

www.dlco.com

Tel: 800-569-6577

Fax: 402-460-4612

e-mail: DLsales@dutton-lainson.com

In Europe Contact

Bainbridge International Ltd.

8 Flanders Park

Hedge End

Southampton

Hampshire, SO30 2FZ

UK

Tel: +44 (0) 1489-776050

Fax: +44 (0) 1489-776055

www.bainbridgmarine.co.uk

ENGLISH-To obtain a copy of the warranty in English, send a self-addressed envelope to: Dutton-Lainson Company; P.O. Box 729; Hastings NE 68902-0729; U.S.A.

DANSK-Man kan få garantibeviset på dansk ved at sende en svarkuvert til: Dutton-Lainson Company, P.O. Box 729, Hastings NE 68902-0729, USA.

SUOMI-Takuutodistuksesta saa suomenkielisen kopion lähettämällä riittäväällä postimaksulla ja vastaanottajan osoitteella varustetun kirjekuoren osoitteeseen Dutton-Lainson Company, P.O. Box 729, Hastings NE 68902-0729, USA.

NEDERLANDS-Voor een exemplaar van de garantie in het Nederlands dient u een aan u zelf geadresseerde enveloppe te zenden naar: Dutton-Lainson Company; P.O. Box 729; Hastings NE 68902-0729; U.S.A.

FRANÇAIS-Pour obtenir une copie de la garantie en français, envoyer une enveloppe à votre nom et adresse à : Dutton-Lainson Company; P.O. Box 729; Hastings NE 68902-0729; U.S.A.

DEUTSCH-Wenn Sie eine deutsche Kopie der Garantibestimmungen erhalten möchten, senden Sie bitte einen adressierten Rückumschlag an: Dutton-Lainson Company; P.O.Box 729; Hastings NE 68902-0729; USA

ITALIANO-Per ricevere una copia della garanzia in italiano, inviare una busta riportante il proprio indirizzo a: Dutton-Lainson Company, P.O. Box 729, Hastings NE 68902-0729 USA.

NORSK-En kopi av denne garantien på norsk fås ved å sende en konvolutt med eget navn og adresse, til Dutton-Lainson Company, P.O. Box 729, Hastings NE 68902-0729, USA

PORTUGUÊS-Para obter uma cópia da garantia em português, envie um envelope com a sua morada para: Dutton-Lainson; P. O. Box 729; Hastings NE 68902-0729; E.U.A.

ESPAÑOL-Para obtener una copia de la garantía en español, envíe un sobre con su dirección impresa a: Dutton-Lainson Company, P.O. Box 729; Hastings NE 68902-0729 EE.UU.

SVENSKA-För att erhålla ett exemplar av garantin på svenska skicka ett adresserat kuvert till: Dutton-Lainson Company, P.O.Box 729, Hastings NE 68902-0729 U.S.A.

ΕΛΛΗΝΙΚΑ-Για να λάβετε ένα αντίγραφο της εγγύησης στα Ελληνικά, στείλτε ένα φάκελο εσωκλείοντας τα ταχυδρομικά τέλη αποστολής στην εξής διεύθυνση: Dutton-Lainson Company, P.O.Box 729, Hastings NE 68902-0729 U.S.A.