

75155

Submitted Model No.: _____

Specific Features: _____

75155 1.5 GPM



Water-Saving
Spray

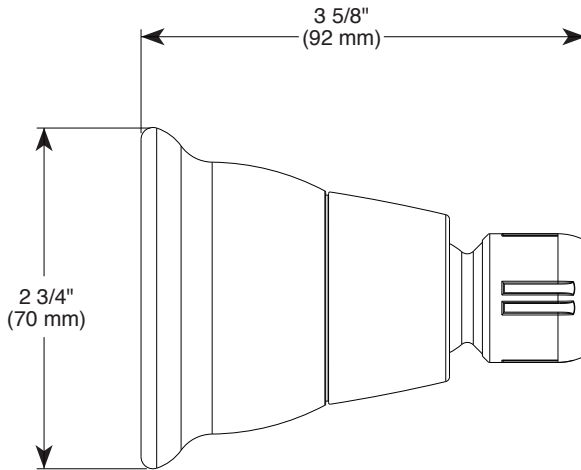

SHOWERHEAD

■ Economy Water-Saving showerhead

STANDARD SPECIFICATIONS:

- Standard 1/2" pipe fitting.
- Patented motion of water; spray holes will not clog up from minerals in your water.
- Four large spray jets precisely angle sprays to provide full-body coverage
- Increases the water's velocity to enhance spray performance and maintain temperature.
- Maximum water consumption 1.5 gpm (5.7 L/min) @ 80 psi.
- Actual water consumption 1.12 gpm (4.28 L/min) @ 45 psi.
- For use with automatic compensating valves rated at 1.0 gpm (3.8 L/min) or less.

WARRANTY

- Lifetime limited warranty on parts (other than electronic parts and batteries) and finishes; or for commercial users, for 5 years from the date of purchase.
- 5 year limited warranty on electronic parts (other than batteries); or for commercial users, for 1 year from the date of purchase. No warranty is provided on batteries.



COMPLIES WITH

- ASME A112.18.1/CSA B125.1



55 E. 111th Street, Indianapolis, Indiana 46280
 350 South Edgeware Road, St. Thomas, Ontario Canada N5P 4L1
 © 2016 Masco Corporation of Indiana