

Electrical Sector Solutions

# Volume 1: Residential and Light Commercial

**EATON**

*Powering Business Worldwide*

# Volume 1 – Residential and Light Commercial

1

Tab 1—Loadcenters and Circuit Breakers .....	V1-T1-1
Tab 2—Surge Protection .....	V1-T2-1
Tab 3—Residential Backup Transfer Switch Solutions .....	V1-T3-1
Tab 4—Metering Products .....	V1-T4-1
Tab 5—Power Pedestals .....	V1-T5-1
Tab 6—Air Conditioning Disconnects .....	V1-T6-1
Appendix 1—Eaton Terms & Conditions .....	V1-A1-1
Appendix 2—Catalog Parent Number Index .....	V1-A2-1
Appendix 3—Alphabetical Product Index .....	V1-A3-1

## Volume 2 – Commercial Distribution

2

## Volume 3 – Power Distribution and Control Assemblies

3

## Volume 4 – Circuit Protection

4

## Volume 5 – Motor Control and Protection

5

## Volume 6 – Solid-State Motor Control

6

## Volume 7 – Logic Control, Operator Interface and Connectivity Solutions

7



## Dimensions, Weights and Ratings

Dimensions, weights and ratings given in this catalog **are approximate and should not be used for construction purposes**. Drawings containing exact dimensions are available upon request. All listed product specifications and ratings are subject to change without notice. Photographs are representative of production units.

## Terms and Conditions

All prices and discounts are subject to change without notice. When price changes occur, they are published in Eaton's *Price and Availability Digest* (PAD). All orders accepted by Eaton's Electrical Sector are subject to the general terms and conditions as set forth in Appendix 1—Eaton Terms & Conditions.

## Technical and Descriptive Publications

This catalog contains brief technical data for proper selection of products. Further information is available in the form of technical information publications and illustrated brochures. If additional product information is required, contact your local Eaton Products Distributor, call **1-800-525-2000** or visit our website at **[www.eaton.com](http://www.eaton.com)**.

## Compliance with Nuclear Regulation 10 CFR 21

Eaton products are sold as commercial grade products not intended for application in facilities or activities licensed by the United States Nuclear Regulatory Commission for atomic purposes, under 10 CFR 21. Further certification will be required for use of these products in a safety-related application in any nuclear facility licensed by the U.S. Nuclear Regulatory Commission.

## WARNING

The installation and use of Eaton products should be in accordance with the provisions of the U.S. National Electrical Code® and/or other local codes or industry standards that are pertinent to the particular end use. Installation or use not in accordance with these codes and standards could be hazardous to personnel and/or equipment.

These catalog pages do not purport to cover all details or variations in equipment, nor to provide for every possible contingency to be met in connection with installation, operation or maintenance. Should further information be desired or should particular problems arise which are not covered sufficiently for the purchaser's purposes, the matter should be referred to the local Eaton Products Distributor or Sales Office. The contents of this catalog shall not become part of or modify any prior or existing agreement, commitment or relationship. The sales contract contains the entire obligation of Eaton's Electrical Sector. The warranty contained in the contract between the parties is the sole warranty of Eaton. Any statements contained herein do not create new warranties or modify the existing warranty.



Powering Business Worldwide

**Eaton is a global leader in power distribution, power quality, control and automation, and monitoring products.**

At Eaton, we believe a reliable, efficient and safe power system is the foundation of every successful enterprise. Through innovative technologies, cutting-edge products and our highly skilled services team, we empower businesses around the world to achieve a powerful advantage.

In addition, Eaton is committed to creating and maintaining powerful customer relationships built on a foundation of excellence. From the products we manufacture to our dedicated customer service and support, we know what's important to you.

## Solutions

Eaton takes the complexity out of power systems management with a holistic and strategic approach, leveraging our industry-leading technology, solutions and services. We focus on the following three areas in all we do:

- Reliability—maintain the appropriate level of power continuity without disruption or unexpected downtime
- Efficiency—minimize energy usage, operating costs, equipment footprint and environmental impact
- Safety—identify and mitigate electrical hazards to protect what you value most

## Using the Eaton Catalog Library

As we grow, it becomes increasingly difficult to include all products in one or two comprehensive catalogs. Knowing that each user has their specific needs, we have created a library of catalogs for our products that when complete, will contain 15 volumes. Since the volumes will continuously be a work in progress and updated, each volume will stand alone. Refer to our volume directory, MZ08100001E, for a quick glance of where to look for the products you need. The 15 volumes include:

- Volume 1—Residential and Light Commercial (CA08100002E)
- Volume 2—Commercial Distribution (CA08100003E)
- Volume 3—Power Distribution and Control Assemblies (CA08100004E)
- Volume 4—Circuit Protection (CA08100005E)
- Volume 5—Motor Control and Protection (CA08100006E)
- Volume 6—Solid-State Motor Control (CA08100007E)
- Volume 7—Logic Control, Operator Interface and Connectivity Solutions (CA08100008E)
- Volume 8—Sensing Solutions (CA08100010E)
- Volume 9—Original Equipment Manufacturer (CA08100011E)
- Volume 10—Enclosed Control (CA08100012E)
- Volume 11—Vehicle and Commercial Controls (CA08100013E)
- Volume 12—Aftermarket, Renewal Parts and Life Extension Solutions (CA08100014E)
- Volume 13—Counters, Timers and Tachometers (CA08100015E)—Available in electronic format only
- Volume 14—Fuses (CA08100016E)—Available in electronic format only
- Volume 15—Solar Inverters and Electrical Balance of System (CA08100018E)

These volumes are not all-inclusive of every product, but they are meant to be an overview of our product lines. For our full range of product solutions and additional product information, consult [Eaton.com/electrical](http://Eaton.com/electrical) and other catalogs and product guides in our literature library. These references include:

- The Consulting Application Guide (CA08104001E)
- The Eaton Power Quality Product Guide (COR01FYA)

If you don't have the volume that contains the product or information that you are looking for, not to worry. You can access every volume of the catalog library at [Eaton.com/electrical](http://Eaton.com/electrical) in the Literature Library.

By installing our Automatic Tab Updater (ATU), you can be sure you always have the most recent version of each volume and tab.

## Icons



### Green Leaf

Eaton Green Solutions are products, systems or solutions that represent Eaton benchmarks for environmental performance. The green leaf symbol is our promise that the solution has been reviewed and documented as offering exceptional, industry-leading environmental benefits to customers, consumers and our communities. Though all of Eaton's products and solutions are designed to meet or exceed applicable government standards related to protecting the environment, our products with the Green Leaf designation further provide "exceptional environmental benefit."



### Learn Online

When you see the Learn Online icon, go to [Eaton.com/electrical](http://Eaton.com/electrical) and search for the product or training page. There you will find 100-level training courses, podcasts, webcasts or games and puzzles to learn more.



### Drawings Online

When you see the Drawings Online icon, go to [Eaton.com/electrical](http://Eaton.com/electrical) and find the products page. There you will find a tab that includes helpful product drawings and illustrations.

## Contact Us

If you need additional help, you can find contact information under the Customer Care heading of [Eaton.com/electrical](http://Eaton.com/electrical).

# Loadcenters and Circuit Breakers

Residential Loadcenters and Breaker Family



<b>1.1</b>	<b>Type CH Loadcenters and Circuit Breakers</b>	
	Overview	V1-T1-2
	Single-Phase	V1-T1-6
	Three-Phase	V1-T1-11
	CH Specialty Products	V1-T1-13
	Spa Panels	V1-T1-13
	Surge Panel	V1-T1-14
	Plug-On Neutral Loadcenter	V1-T1-16
	Type CH Renovation Loadcenter	V1-T1-17
	Type CH Retrofit Interior Kits	V1-T1-18
	Non-Metallic Loadcenter	V1-T1-20
	CH Loadcenter Options and Accessories	V1-T1-21
	CH Circuit Breakers	V1-T1-31
<b>1.2</b>	<b>Type BR Loadcenters and Circuit Breakers</b>	
	Overview	V1-T1-42
	Single-Phase	V1-T1-54
	Three-Phase	V1-T1-54
	BR Specialty Products	V1-T1-57
	BR Quick Connect Neutral Loadcenters	V1-T1-57
	Spa Panels	V1-T1-58
	Riser Panel	V1-T1-59
	Type BR Renovation Loadcenter	V1-T1-60
	Type BR Retrofit Interior Kits	V1-T1-61
	BR Loadcenter Options and Accessories	V1-T1-63
	BR Circuit Breakers	V1-T1-77
<b>1.3</b>	<b>Loadcenter Interiors/OEM Loadcenters</b>	
	Product Description	V1-T1-89
	Standards and Certifications	V1-T1-90
	Product Selection	V1-T1-90
<b>1.4</b>	<b>Enclosed Breakers</b>	
	Product Description	V1-T1-94
	Standards and Certifications	V1-T1-94
	Product Selection	V1-T1-95
	Dimensions	V1-T1-95
<b>1.5</b>	<b>Classified Circuit Breakers</b>	
	Product Description	V1-T1-96
	Product Selection	V1-T1-97
	Accessories	V1-T1-99
	Technical Data	V1-T1-99
	Wiring Diagrams	V1-T1-100



Eaton Type CH Convertible Family



### Contents

<i>Description</i>	<i>Page</i>
Overview	
Standards and Certifications . . . . .	<b>V1-T1-3</b>
Catalog Number Selection . . . . .	<b>V1-T1-5</b>
Product Selection . . . . .	<b>V1-T1-6</b>
CH Specialty Products . . . . .	<b>V1-T1-13</b>
CH Loadcenter Options and Accessories . . . . .	<b>V1-T1-21</b>
CH Circuit Breakers . . . . .	<b>V1-T1-31</b>

### Overview

#### Product Description

Loadcenters are enclosures specifically designed to house the branch circuit breakers and wiring required to distribute power to individual circuits. They contain either a main breaker when used at the service entrance point or a main lug when used as a sub-panel to add circuits to existing service. The main breaker protects the main entire panel and can be used as a service disconnect. The branch breakers protect the wires leading to individual electrical loads such as fixtures and outlets.

#### Features, Benefits and Functions

##### Loadcenter Construction

Eaton’s Type CH loadcenters feature silver flash plated copper bus in all interiors. Stabs are rated 200 A throughout the CH line. Therefore, the sum of the handle ratings connected to any one stab is limited to 200 A maximum. NEMA 1 boxes are manufactured from cold rolled 16 gauge sheet steel. Raintight boxes are manufactured from galvanized steel. All boxes and trims are finished using an electrostatic powder coat, baked urethane paint process.

##### Neutrals

Eaton Type CH loadcenters feature two types of neutrals:

##### Insulated/Bondable Split Neutral

Panels are supplied with split insulated neutrals with an insulated cross strap. For service entrance applications, the neutral must be bonded by using the bonding strap supplied with the panel. For non-service entrance (sub-panel) applications, the panel may be installed with the bonding strap not connected to the neutral. Separate ground bars must be used on non-service entrance panels.

##### Insulated/Bondable Single Neutral

Panels are supplied with a single insulated neutral. For service entrance applications, all that is required to bond the neutral is to loosen the bonding screw and the neutral screw directly beside it, insert the bonding strap into the neutral bar, and re-tighten both connections. The single neutral can be moved by the contractor to the other side of the panel, if desired. When used as a service entrance panel, unused neutral connections may be used for the termination of equipment grounds. For non-service entrance (sub-panel) applications, the panel may be installed with the bonding strap not connected to the neutral. Separate ground bars must be used on non-service entrance panels.

##### Inboard Plug-On Neutral

Code changes and higher safety standards are leading to more arc fault circuit interrupter (AFCI) installations. With the electrical contractor in mind, Eaton has revolutionized the way Combination AFCIs are installed with the Plug-on Neutral line of loadcenters and breakers.

This unique product solution enables the contractor to connect the breaker directly to the neutral bar, eliminating the need for wiring a pigtail.

##### Grounds

In service entrance applications where the neutral is bonded, unused neutral holes may be used for terminating ground conductors. In sub-feed panels, the neutral must be isolated (non-bonded), and ground wires must be terminated on a separate ground bar.

The insulated/bondable single/split neutral panels have sufficient terminations for both ground and neutral conductors. The insulated/bondable single split neutral panels are supplied with a separate factory-installed ground bar if the catalog number contains a “G.” If not, a separate ground bar should be installed. Insulated/Bondable Single Neutral panels are supplied without a ground bar (unless otherwise noted), and ground bar kits, if needed, must be purchased separately.

**Neutral and Ground Terminals**

The standard terminals on grounds and neutrals are rated to accept (3)—#14—#10 Cu/Al or (1)—#14—4 wires. For larger cables, add-on neutral lugs may be ordered from the Accessories.

**Note:** NEC® allows only one current carrying conductor per hole on neutrals unless otherwise noted.

**Bottom-Fed Loadcenters**

When the power cable is brought into the loadcenter from below the panel; then the main lug panels, and single-phase, 225 A and below, loadcenters can be rotated 180 degrees to allow straight-in wiring of power cables to the main terminals. Because the CSR main circuit breaker handle operates horizontally, the orientation of the main circuit breaker handle is consistent with the requirements of NEC Article 240.81.

**Gutter Splicing**

Loadcenters are not UL listed as wiring troughs. Therefore, gutter splicing of riser cables to tap off to the main device is not permitted. Refer to NEC Article 373.8.

**Fire Rating**

Due to the numerous openings in both loadcenter boxes and trims, they should not be mounted in firewalls. There is no approval method for sealing the enclosures for this application.

**Date Code**

The date of manufacture of each loadcenter is printed on the outside of the carton as well as inside the loadcenter. On the carton, the date code is printed on the end carton label. In the loadcenter, the date code is located on the small white label located on the right side wall (with the main device on top).

The date code is in the following format: F # # # &. The “F” is the numeric code for the Lincoln, IL plant, and the three numbers are the year and week of manufacture, e.g., 023. The “&” sign at the end signifies the decade of the 2000s. The “!” at the end signifies the decade of the 2010s. Therefore, the date code F023& would indicate that the product was manufactured in the 23rd week of 2000. The 1980s are represented by a “+” sign and the 1990s are represented by a “=” at the end of the code.

**Plug-On Type CH Breakers**

Quick-make, quick-break switch mechanism combined with inverse time element tripping operation and trip-free handle design. Type CH circuit breakers trip to the OFF position eliminating nuisance callbacks. The thermal-magnetic trip curve avoids nuisance tripping on mild overloads while reacting almost instantaneously to severe short-circuit conditions. CHF breakers include a ‘trip flag’ to differentiate between a tripped breaker and one that has been turned off. Multipole breakers have internal common trip connection to operate all poles simultaneously. Handles are marked with ON-OFF indication and ampere rating of the breaker. Type CH breakers meet UL Standard 489, NEMA standards, and Federal Spec Classification W-C 375 b/Gen. They are UL listed under File Number E11713, E8741, E3624 and E51287; and CSA® certified file number LR87196, except Type CHT breakers.

**Type CH Circuit Breaker Ratings**

Single- and double-pole CH breakers rated 15 and 20 A have low instantaneous magnetic trip levels. The 15 and 20 A breakers with “HM” suffix have high magnetic trip settings recommended for circuits with inherently high inrush currents. All Type CH breakers are marked for heating, air conditioning and refrigeration (HACR) equipment application. Single-pole 15–20 A breakers are also suitable for switching duty (SWD). Shunt trip coils operate on 120 Vac and require one additional pole space per breaker.

**Standards and Certifications****UL® Listings**

All Eaton Type CH loadcenters are listed under the UL 67 certification in file E8741.





# 1.1

## Loadcenters and Circuit Breakers

### Type CH Loadcenters and Circuit Breakers

1

#### Type CH Loadcenter

Extra 1.5 inch Knockout (38.1 mm)

- Larger knockout provides easier installation and time savings for renovation installations

Top or Bottom Feed

- Straight-in wiring saves labor and material
- One panel for either top or bottom applications

2/0 Lug

- Easily removable and can be installed in any location on the neutral bar

Commercial Grade Main Breaker

- 25 kAIC series rated main breaker in 150 A–225 A loadcenters. 35, 42 and 100 kAIC series ratings are available
- Optional convertible design—reduces inventory requirements

One Piece Silver-Flashed Copper Bus

- Provides superior conductivity, corrosion resistance and durability

Drywall Marking on Enclosure

- Indicates proper mounting depth for flush applications

Steel Backpan

- Provides solid and reliable breaker mounting—single piece design for stability and durability

“Tangential” Center Knockout

- Easier installation for conduit applications

Unique Sandalwood Finish

- Aesthetically appealing, scratch-resistant powder coating

Neutral Bus (Strap)

- Easily removable for sub-panel applications

Bonding Z-Strap

- Provides easy field conversion for service entrance applications

Twin Neutral Bars

- Minimum 150% neutral capacity

Type CHF AFCI/GFCI/Thermal-Magnetic Breakers

- Advanced electronics effectively reduce nuisance tripping
- CHF AFCI breakers have a standard diagnostic LED indicating 1 of 7 trip codes
- Mechanical flag for trip indication (on thermal-magnetic AFCI and GFCI)
- All CH breakers provide industry exclusive 2-position handle with simple 1 step reset

Single Keyhole Mounting

- One keyhole at the top and bottom provides easier mounting and leveling

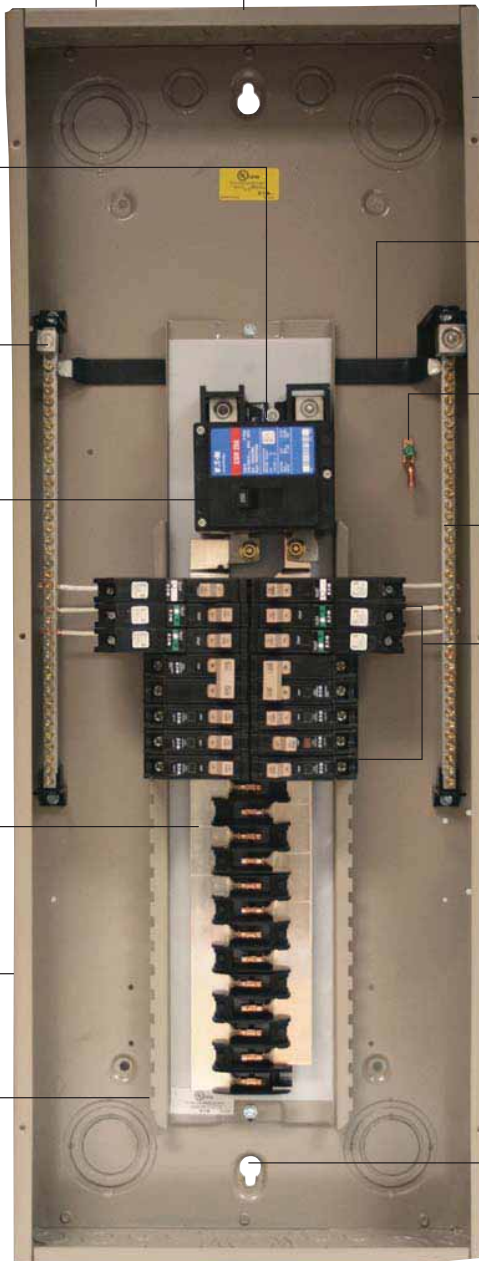

#### Warranty

The minimum warranty for residential loadcenters, breakers and surge protection devices shall be as follows:

- Lifetime loadcenter warranty
- Lifetime warranty on CH circuit breakers
- Lifetime warranty on CHSPT2ULTRA including \$75,000 connected equipment warranty
- 1-year warranty on plug-in surge protective device (CHSA)

### Catalog Number Selection

#### Loadcenters 100–225 A and 12–42 Circuits

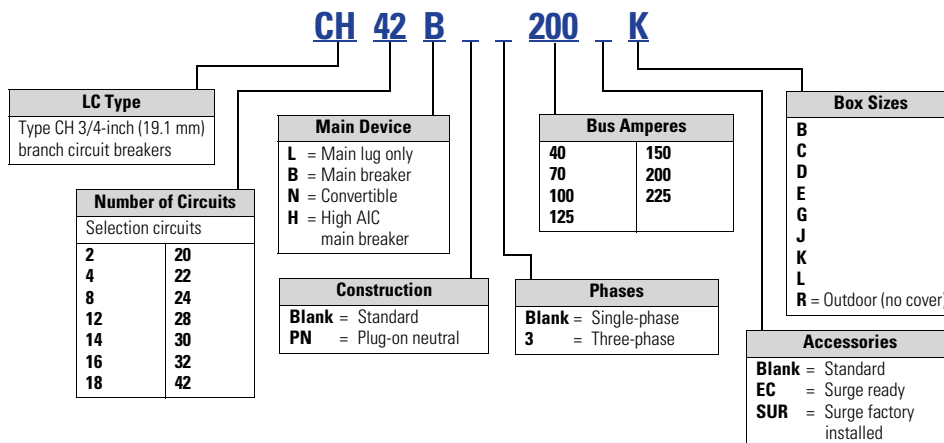

#### Indoor Covers Ordered Separately

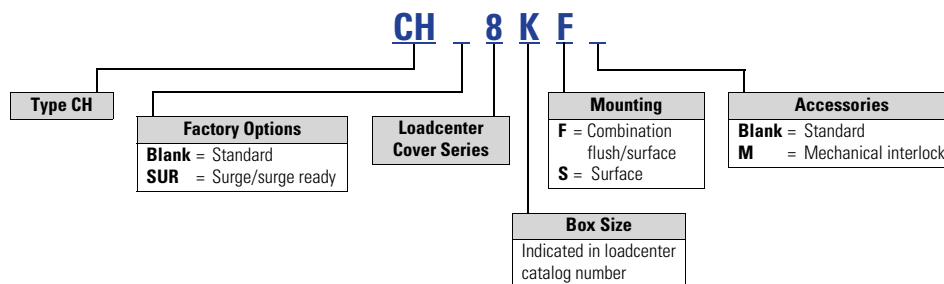

**Note:** All combinations are not valid, refer to the catalog section.

# 1.1

## Loadcenters and Circuit Breakers

### Type CH Loadcenters and Circuit Breakers

#### 1

#### Product Selection

#### Single-Phase—Main Circuit Breaker Loadcenters—10/25 kAIC

CH42B200K



#### Single-Phase Three-Wire—120/240 Vac—Insulated/Bondable Split Neutral (Unless Otherwise Noted)

Main Breaker Type	Main Ampere Rating	Maximum Number 3/4-Inch (19.1 mm) of Poles	Enclosure Type	Box Size	Wire Size Range Cu/Al 60 °C or 75 °C for Main Breaker	Loadcenter <sup>①②</sup> Catalog Number	Loadcenter Cover Catalog Number	Surface	
CH 10 kAIC	100	14	Indoor	B	#6–1/0	CH14B100B <sup>④</sup>	CH8BF	CH8BS	
		14	Outdoor	B	#6–1/0	CH14B100R <sup>⑤</sup>	—	—	
		18	Indoor	C	#6–1/0	CH18B100C <sup>④</sup>	CH8CF	CH8CS	
		18	Outdoor	C	#6–1/0	CH18B100R <sup>⑤</sup>	—	—	
		22	Indoor	C	#6–1/0	CH22B100C <sup>④</sup>	CH8CF	CH8CS	
		22	Outdoor	C	#6–1/0	CH22B100R <sup>⑤</sup>	—	—	
	125	125	30	Indoor	D	#6–1/0	CH30B100D <sup>④</sup>	CH8DF	CH8DS
			30	Outdoor	D	#6–1/0	CH30B100R <sup>⑤</sup>	—	—
			22	Indoor	C	#6–1/0	CH22B125C <sup>④</sup>	CH8CF	CH8CS
			22	Outdoor	C	#6–1/0	CH22B125R <sup>⑤</sup>	—	—
			30	Indoor	D	#6–1/0	CH30B125D <sup>④</sup>	CH8DF	CH8DS
			30	Outdoor	D	#6–1/0	CH30B125R <sup>⑤</sup>	—	—
CSR 25 kAIC	150	8	Outdoor	E	#2–300 kcmil	CH8B150RF <sup>⑥</sup>	—	—	
		24	Indoor	E	#2–300 kcmil	CH24B150E <sup>④</sup>	CH8EF	CH8ES	
		24	Outdoor	E	#2–300 kcmil	CH24B150R <sup>⑤</sup>	—	—	
		32	Indoor	J	#2–300 kcmil	CH32B150J <sup>④</sup>	CH8JF	CH8JS	
		32	Outdoor	J	#2–300 kcmil	CH32B150R <sup>⑤</sup>	—	—	
		200	200	8	Outdoor	E	#2–300 kcmil	CH8B200RF <sup>⑥</sup>	—
	24	Indoor		E	#2–300 kcmil	CH24B200E <sup>④</sup>	CH8EF	CH8ES	
	24	Outdoor		E	#2–300 kcmil	CH24B200R <sup>⑤</sup>	—	—	
	32	Indoor		J	#2–300 kcmil	CH32B200J <sup>④</sup>	CH8JF	CH8JS	
	32	Outdoor		J	#2–300 kcmil	CH32B200R <sup>⑤</sup>	—	—	
	42	Indoor		K	#2–300 kcmil	CH42B200K <sup>④</sup>	CH8KF	CH8KS	
	225	225	42	Outdoor	K	#2–300 kcmil	CH42B200R <sup>⑤</sup>	—	—
32			Indoor	J	#2–300 kcmil	CH32B225J <sup>④</sup>	CH8JF	CH8JS	
32			Outdoor	J	#2–300 kcmil	CH32B225R <sup>⑤</sup>	—	—	
42			Indoor	K	#2–300 kcmil	CH42B225K <sup>④</sup>	CH8KF	CH8KS	
42			Outdoor	K	#2–300 kcmil	CH42B225R <sup>⑤</sup>	—	—	
DK 10 kAIC			300	42	Indoor	PM	(2) 3/0–250 kcmil	CH42PM300	CH7PMF <sup>⑦</sup>
	400	42	Indoor	PM	(2) 3/0–250 kcmil	CH42PM400	CH7PMF <sup>⑦</sup>	CH7PMS	

#### Notes

- ① All main circuit breaker loadcenters are listed for use as service entrance equipment.
- ② Ground bar kits priced separately. See **Page V1-T1-24**.
- ③ Combination style covers may be used in surface or flush applications.
- ④ Can be top or bottom fed by rotating the enclosure and trim 180 degrees.
- ⑤ Rainproof panels are furnished with hub closure plates. For rainproof hubs, refer to **Page V1-T1-24**.
- ⑥ Panel includes #4–300 kcmil feed-through lugs.
- ⑦ This cover is for flush applications only (not combination).

Box sizes **Pages V1-T1-29** and **V1-T1-30**.

### Single-Phase—High Interrupting Rated Main Circuit Breaker Loadcenters—100 kAIC

#### Single-Phase Three-Wire—120/240 Vac—Insulated/Bondable Split Neutral

Main Breaker Type	Main Ampere Rating	Maximum Number 3/4-Inch (19.1 mm) Poles	Enclosure Type	Box Size	Wire Size Range Cu/Al 60 °C or 75 °C for Main Breaker	Loadcenter <sup>①</sup> Catalog Number	Loadcenter Cover Catalog Number Combination <sup>②</sup>	Surface
CHB4 100 kAIC <sup>⑤</sup>	100	32	Indoor	L	#6–1/0	CH32H100L <sup>③</sup>	CH8LF	CH8LS
		32	Outdoor	L	#6–1/0	CH32H100R <sup>④</sup>	—	—
CHH 100 kAIC <sup>⑤</sup>	150	32	Indoor	L	#2/0–300 kcmil	CH32H150L	CH8LF	CH8LS
		32	Outdoor	L	#2/0–300 kcmil	CH32H150R <sup>④</sup>	—	—
	200	32	Indoor	L	#2/0–300 kcmil	CH32H200L	CH8LF	CH8LS
		32	Outdoor	L	#2/0–300 kcmil	CH32H200R <sup>④</sup>	—	—
		42	Indoor	L	#2/0–300 kcmil	CH42H200L	CH8LF	CH8LS
		42	Outdoor	L	#2/0–300 kcmil	CH42H200R <sup>④</sup>	—	—
	225	42	Indoor	L	#2/0–300 kcmil	CH42H225L	CH8LF	CH8LS
		42	Outdoor	L	#2/0–300 kcmil	CH42H225R <sup>④</sup>	—	—

#### Notes

- ① All main circuit breaker loadcenters are listed for use as service entrance equipment.
- ② Combination style covers may be used in surface or flush applications.
- ③ Loadcenter can be top or bottom fed by rotating the enclosure and trim 180 degrees.
- ④ Rainproof panels are furnished with hub closure plates. For rainproof hubs, refer to **Page V1-T1-24**.
- ⑤ Series rated for 100 kAIC with all Types CH, CHT and CHP breakers.

# 1.1





## Loadcenters and Circuit Breakers

### Type CH Loadcenters and Circuit Breakers

1

#### Single-Phase—Main Lug Loadcenters

#### Single-Phase Three-Wire—120/240 Vac—Insulated/Bondable Single Neutral

Main Ampere Rating	Maximum Number 3/4-Inch (19.1 mm)		Enclosure Type	Type of Trim (Included)	Box Size	Wire Size Range Cu/Al 60 °C or 75 °C for Main Lugs	Loadcenter Catalog Number	
	Space	Poles						
Surface Outdoor		2	4 ①	Indoor	Surface (no door)	5	#14–6	<b>CH2L40SP</b> ②③
		2	4 ①	Outdoor	—	5R	#14–6	<b>CH2L40RP</b> ②③④
		2	4 ①	Indoor	Flush (no door)	5	#14–6	<b>CH2L40FP</b> ②③
Flush Outdoor		2	4 ①	Indoor	Surface (no door)	5	#14–2	<b>CH2L70SP</b> ②③
		2	4 ①	Outdoor	—	5R	#14–2	<b>CH2L70RP</b> ②③④
		2	4 ①	Indoor	Flush (no door)	5	#14–2	<b>CH2L70FP</b> ②③
Surface (No Door)		2	4 ①	Indoor	Surface (no door)	6	#14–1/0	<b>CH2L125SP</b> ②③
		2	4 ①	Outdoor	—	6R	#14–1/0	<b>CH2L125RP</b> ②③④
		2	2	Outdoor	—	—	#14–1/0	<b>CH2L125RSE2P</b> ④⑤⑥
		2	4 ①	Indoor	Flush (no door)	6	#14–1/0	<b>CH2L125FP</b> ②③
		4	8 ①	Indoor	Surface (no door)	7	#14–1/0	<b>CH4L125SP</b> ②⑦
		4	8 ①	Outdoor	—	7R	#14–1/0	<b>CH4L125RP</b> ②④⑦
		4	8 ①	Indoor	Flush (no door)	7	#14–1/0	<b>CH4L125FP</b> ②⑦
		6	12 ①	Outdoor	—	6R	#14–1/0	<b>CH6L125R</b> ②⑥⑦
		8	16 ①	Indoor	Surface (no door)	7	#6–1/0	<b>CH8L125SP</b> ②⑧
		8	16 ①	Outdoor	—	7R	#6–1/0	<b>CH8L125RP</b> ②⑧⑦
Flush (No Door)		8	16 ①	Indoor	Surface (no door)	7	#6–1/0	<b>CH8L125SP</b> ②⑧
		8	16 ①	Outdoor	—	7R	#6–1/0	<b>CH8L125RP</b> ②⑧⑦
Outdoor		8	16 ①	Indoor	Flush (no door)	7	#6–1/0	<b>CH8L125FP</b> ②⑧
		8	16 ①	Outdoor	—	7R	#6–1/0	<b>CH8L125RP</b> ②⑧⑦

#### Notes

- ① Requires the use of Type CHT breakers.
- ② Ground bar kits priced separately, see **Page V1-T1-24**.
  - For 2/4 and 6/12 circuit loadcenters, use Type GBK5 or GBK520 ground bar
  - For 4/8 and 8/16 circuit loadcenters, use Type GBK10 ground bar
  - Ground bars mount to the left side wall of the enclosure for the 4/8, 6/12 and 8/16 circuit loadcenters
- ③ Suitable for use as service equipment when not more than two service disconnecting mains are provided or when not used as a lighting and appliance panelboard.
- ④ Rainproof panels are furnished with hub closure plates. For rainproof hubs, refer to **Page V1-T1-24**.
- ⑤ For use as service entrance applications only.
- ⑥ Neutral/ground holes (6) #14–6 and (3) #14–2/0 AWG Cu/Al.
- ⑦ Suitable for use as service equipment when not more than two service disconnecting mains are provided or when not more than six service disconnecting mains are provided and when not used as a lighting and appliance panelboard.
- ⑧ Suitable for use as service equipment when a main breaker is used or when not more than six service disconnecting mains are provided and when not used as a lighting and appliance panelboard.

Box sizes **Pages V1-T1-29 and V1-T1-30**.

CH42L225G



### Single-Phase Three-Wire—120/240 Vac—Insulated/Bondable Split Neutral—Factory-Installed Ground Bar

Main Ampere Rating	Maximum Number 3/4-Inch (19.1 mm) Poles	Enclosure Type	Box Size	Wire Size Range Cu/Al 60 °C or 75 °C for Main Lugs	Loadcenter Catalog Number	Loadcenter Cover	
						Catalog Number Combination	Surface
125	12	Indoor	B	#6–2/0	CH12L125B <sup>①</sup>	CH8BF	CH8BS
	12	Outdoor	B	#6–2/0	CH12L125R <sup>①②</sup>	—	—
	16	Indoor	B	#6–2/0	CH16L125B <sup>①</sup>	CH8BF	CH8BS
	16	Outdoor	B	#6–2/0	CH16L125R <sup>①②</sup>	—	—
	20	Indoor	C	#6–2/0	CH20L125C <sup>①</sup>	CH8CF	CH8CS
	20	Outdoor	C	#6–2/0	CH20L125R <sup>①②</sup>	—	—
	24	Indoor	C	#6–2/0	CH24L125C <sup>①</sup>	CH8CF	CH8CS
	24	Outdoor	C	#6–2/0	CH24L125R <sup>①②</sup>	—	—
150	24	Indoor	D	#4–300 kcmil	CH24L150D <sup>①</sup>	CH8DF	CH8DS
	24	Outdoor	D	#4–300 kcmil	CH24L150R <sup>②③</sup>	—	—
	32	Indoor	D	#4–300 kcmil	CH32L150D <sup>①</sup>	CH8DF	CH8DS
	32	Outdoor	D	#4–300 kcmil	CH32L150R <sup>②③</sup>	—	—
200	12	Indoor	D	#4–300 kcmil	CH12L200D <sup>①</sup>	CH8DF	CH8DS
	12	Outdoor	D	#4–300 kcmil	CH12L200R <sup>②③</sup>	—	—
	16	Indoor	D	#4–300 kcmil	CH16L200D <sup>①</sup>	CH8DF	CH8DS
	16	Outdoor	D	#4–300 kcmil	CH16L200R <sup>②③</sup>	—	—
225	24	Indoor	D	#4–300 kcmil	CH24L225D <sup>①</sup>	CH8DF	CH8DS
	24	Outdoor	D	#4–300 kcmil	CH24L225R <sup>②③</sup>	—	—
	32	Indoor	D	#4–300 kcmil	CH32L225D <sup>①</sup>	CH8DF	CH8DS
	32	Outdoor	D	#4–300 kcmil	CH32L225R <sup>②③</sup>	—	—
	42	Indoor	G	#4–300 kcmil	CH42L225G <sup>③</sup>	CH8GF	CH8GS
	42	Outdoor	G	#4–300 kcmil	CH42L225R <sup>②③</sup>	—	—
400	42	Indoor	P	(2) 1/0–300 kcmil (1) 750 kcmil	CH42PL400 <sup>④</sup>	CH7PF <sup>⑤</sup>	CH7PS

**Notes**

- ① Suitable for use as service equipment when not more than six disconnecting means are provided and when not used as a lighting and appliance panelboard.
- ② Rainproof panels are furnished with hub closure plates. For rainproof hubs, refer to **Page V1-T1-24**.
- ③ Suitable for use as service equipment when a circuit breaker is used as a main breaker. The main breaker is backfed and requires hold-down bracket kit catalog number **CH125RB**.
- ④ Suitable for use as service equipment when a circuit breaker is used as a main breaker. The main breaker is backfed and must be a Type CHB.  
**The breaker cannot be a Type CH.**
- ⑤ This cover is for flush application only (not combination).

Box sizes **Pages V1-T1-29** and **V1-T1-30**.

# 1.1

## Loadcenters and Circuit Breakers

### Type CH Loadcenters and Circuit Breakers

1

#### Convertible Loadcenters MCB or MLO—Base Units and Main Devices—10/25/35 kAIC

Complete assembly consists of: loadcenter, cover, and either main breaker kit or main lug kit.

#### Indoor—Single-Phase—Three-Wire—120/240 V—Insulated/Bondable Split Neutral—Top or Bottom Feed

Maximum Main Ampere Rating	Maximum Number of Single Poles	Box Size	Loadcenter Box and Panel Catalog Number ①	Loadcenter Cover Catalog Number		Main Lug Kit		Main Breaker Kit		Catalog Number	
				Combination	Surface	Wire Size	Catalog Number	kAIC Rating	Wire Size		
125	22	C	CH22N125C	CH8CF	CH8CS	#10–1/0	CHL125N	10	#10–1/0	CH2100N ③	—
										CH2125N ③	—
200	32	J	CH32N200J	CH8JF	CH8JS	#4–300 kcmil	CHL225N	25/35 ②	#2–300 kcmil	CSR2125N	CSH2125N ④
										CSR2150N	CSH2150N ④
										CSR2175N	CSH2175N ④
										CSR2200N	CSH2200N ④
225	42	K	CH42N225K	CH8KF	CH8KS	#4–300 kcmil	CHL225N	25/35 ②	#2–300 kcmil	CSR2125N	CSH2125N ④
										CSR2150N	CSH2150N ④
										CSR2175N	CSH2175N ④
										CSR2200N	CSH2200N ④
										CSR2225N	CSH2225N ④

#### Outdoor—Single-Phase—Three-Wire—120/240 V—Insulated/Bondable Split Neutral (Unless Otherwise Noted)

Maximum Main Ampere Rating	Maximum Number of Single Poles	Box Size	Loadcenter Box and Panel Catalog Number ①	Main Lug Kit		Main Breaker Kit		Catalog Number	
				Wire Size	Catalog Number	kAIC Rating	Wire Size		
125	22	C	CH22N125R ⑤	#10–1/0	CHL125N	10	#10–1/0	CH2100N ③	—
								CH2125N ③	—
200	8	E	CH8N200RF ⑤⑥⑦	#4–300 kcmil	CHL225N	25/35 ②	#2–300 kcmil	CSR2125N	CSH2125N
								CSR2150N	CSH2150N
								CSR2175N	CSH2175N
								CSR2200N	CSH2200N
200	32	J	CH32N200R ⑤	#4–300 kcmil	CHL225N	25/35 ②	#2–300 kcmil	CSR2125N	CSH2125N ④
								CSR2150N	CSH2150N ④
								CSR2175N	CSH2175N ④
								CSR2200N	CSH2200N ④
225	42	K	CH42N225R ⑤	#4–300 kcmil	CHL225N	25/35 ②	#2–300 kcmil	CSR2125N	CSH2125N ④
								CSR2150N	CSH2150N ④
								CSR2175N	CSH2175N ④
								CSR2200N	CSH2200N ④
								CSR2225N	CSH2225N ④

#### Notes

- ① Panel does not include main. Order main breaker or main lug kit separately.
- ② If 35 kAIC is required, use CSH breaker.
- ③ Hold-down kit included.
- ④ 35 kAIC series combination rating is obtained when Types CH, CHT and CHP branch breakers are used with CSH main.
- ⑤ Rainproof panels are furnished with hub closure plates. For rainproof hubs, refer to **Page V1-T1-24**.
- ⑥ Includes feed-through lugs for both phase and neutral conductors.
- ⑦ Insulated/bondable single neutral.

Interrupting rating depends on main circuit breaker selected.

### Three-Phase—Main Circuit Breaker Loadcenters—10 kAIC

CH42B3200L



#### Three-Phase Four-Wire—208Y/120 Vac or 240 Vac Insulated/Bondable Split Neutral

Main Breaker Type	Main Ampere Rating	Maximum Number 3/4-Inch (19.1 mm) Poles	Enclosure Type	Box Size	Wire Size Range Cu/Al 60 °C or 75 °C for Main Breaker	Loadcenter Catalog Number <sup>①②</sup>	Loadcenter Cover Catalog Number	
							Combination	Surface
CC 10 kAIC	150	30	Indoor	L	#1–4/0	CH30B3150L	CH8LF	CH8LS
			Outdoor	L	#1–4/0	CH30B3150R <sup>③</sup>	—	—
	200	30	Indoor	L	#2/0–300 kcmil	CH30B3200L	CH8LF	CH8LS
			Outdoor	L	#2/0–300 kcmil	CH30B3200R <sup>③</sup>	—	—
		42	Indoor	L	#2/0–300 kcmil	CH42B3200L	CH8LF	CH8LS
			Outdoor	L	#2/0–300 kcmil	CH42B3200R <sup>③</sup>	—	—
	225	30	Indoor	L	#2/0–300 kcmil	CH30B3225L	CH8LF	CH8LS
			Outdoor	L	#2/0–300 kcmil	CH30B3225R <sup>③</sup>	—	—
		42	Indoor	L	#2/0–300 kcmil	CH42B3225L	CH8LF	CH8LS
			Outdoor	L	#2/0–300 kcmil	CH42B3225R <sup>③</sup>	—	—
	400	42	Indoor	PM	(2) 3/0–350 kcmil	CH424PM400	CH7PMF <sup>④</sup>	CH7PMS

### Three-Phase—High Interrupting Rated Main Circuit Breaker Loadcenters—100 kAIC

#### Three-Phase Four-Wire—208Y/120 Vac or 240 Vac Insulated/Bondable Split Neutral

Main Breaker Type	Main Ampere Rating	Maximum Number 3/4-Inch (19.1 mm) of Poles	Enclosure Type	Box Size	Wire Size Range Cu/Al 60 °C or 75 °C for Main Breaker	Loadcenter Catalog Number <sup>①②</sup>	Loadcenter Cover Catalog Number	
							Combination	Surface
CHH 100 kAIC <sup>⑤</sup>	200	30	Indoor	L	#2/0–300 kcmil	CH30H3200L	CH8LF	CH8LS
			Outdoor	L	#2/0–300 kcmil	CH30H3200R <sup>③</sup>	—	—
		42	Indoor	L	#2/0–300 kcmil	CH42H3200L	CH8LF	CH8LS
			Outdoor	L	#2/0–300 kcmil	CH42H3200R <sup>③</sup>	—	—
	225	42	Indoor	L	#2/0–300 kcmil	CH42H3225L	CH8LF	CH8LS
			Outdoor	L	#2/0–300 kcmil	CH42H3225R <sup>③</sup>	—	—

#### Notes

- ① All main circuit breaker loadcenters are listed for use as service entrance equipment.
- ② Ground bar kits priced separately. For ground bar kits, see **Page V1-T1-24**.
- ③ Rainproof loadcenters are furnished with hub closure plates. For rainproof hubs, refer to **Page V1-T1-24**.
- ④ This cover for flush application only (not combination).
- ⑤ 100 kAIC series combination rating is obtained when Types CH and CHP branch breakers are used with CHH main.



# 1.1

## Loadcenters and Circuit Breakers

### Type CH Loadcenters and Circuit Breakers

1

#### Three-Phase—Main Lug Loadcenters

#### Three-Phase Four-Wire—208Y/120 Vac or 240 Vac Insulated/Bondable Split Neutral (Unless Otherwise Noted)

Main Ampere Rating	Maximum Number 3/4-Inch (19.1 mm)		Enclosure Type	Type of Trim Included	Box Size	Wire Size Range Cu/Al 60 °C or 75 °C for Main Lugs	Loadcenter Catalog Number	Loadcenter Cover Catalog Number	
	Spaces	Poles						Combination	Single
125	6	12 <sup>①</sup>	Indoor	Surface, no door	7	#14–1/0	CH6L3125SP <sup>②③④</sup>	—	—
	6	12 <sup>①</sup>	Outdoor	—	7R	#14–1/0	CH6L3125RP <sup>②③④⑤</sup>	—	—
	6	12 <sup>①</sup>	Indoor	Flush, no door	7	#14–1/0	CH6L3125FP <sup>②③④</sup>	—	—
	12	12	Indoor	—	B	#6–2/0	CH12L3125B <sup>⑥⑦</sup>	CH8BF	CH8BS
	12	12	Outdoor	—	B	#6–2/0	CH12L3125R <sup>⑥⑦</sup>	—	—
	18	18	Indoor	—	C	#6–2/0	CH18L3125C <sup>⑥⑦</sup>	CH8CF	CH8CS
	18	18	Outdoor	—	C	#6–2/0	CH18L3125R <sup>⑥⑦⑧</sup>	—	—
	24	24	Indoor	—	C	#6–2/0	CH24L3125C <sup>⑥⑦</sup>	CH8CF	CH8CS
150	30	30	Indoor	—	D	#4–300 kcmil	CH30L3150D <sup>⑥⑦</sup>	CH8DF	CH8DS
	30	30	Outdoor	—	D	#4–300 kcmil	CH30L3150R <sup>⑥⑦⑧</sup>	—	—
225	24	24	Indoor	—	D	#4–300 kcmil	CH24L3225D <sup>⑥⑦</sup>	CH8DF	CH8DS
	24	24	Outdoor	—	D	#4–300 kcmil	CH24L3225R <sup>⑥⑦⑧</sup>	—	—
	30	30	Indoor	—	D	#4–300 kcmil	CH30L3225D <sup>⑥⑦</sup>	CH8DF	CH8DS
	30	30	Outdoor	—	D	#4–300 kcmil	CH30L3225R <sup>⑥⑦⑧</sup>	—	—
	42	42	Indoor	—	G	#4–300 kcmil	CH42L3225G <sup>⑥⑧</sup>	CH8GF	CH8GS
	42	42	Outdoor	—	G	#4–300 kcmil	CH42L3225R <sup>⑥⑦⑧</sup>	—	—
400	42	42	Indoor	—	P	(2) 1/0–300 kcmil (1) 750 kcmil	CH424PL400 <sup>⑩⑪</sup>	CH7PF <sup>⑫</sup>	CH7PS

#### Notes

- ① Requires the use of Type CHT breakers.
- ② Suitable for use as service equipment when not more than two service disconnecting means are provided or when not more than six service disconnecting means are provided and when not used as a lighting and appliance panelboard.
- ③ Ground bar kits priced separately, see **Page V1-T1-24**.
  - Use GBK10 ground bar
  - Ground bars mount to the left side wall of the enclosure.
- ④ Insulated/bondable single neutral.
- ⑤ Rainproof loadcenters are furnished with hub closure plates. For rainproof hubs, refer to **Page V1-T1-24**.
- ⑥ Ground bar Type GBK14 is installed.
- ⑦ Suitable for use as service equipment when a circuit breaker is used as a main breaker. The main breaker is backfed and requires hold-down bracket kit catalog number Type **CH125RB**. Suitable for use as service equipment when not more than six service disconnecting means are provided and when not used as a lighting and appliance panelboard.
- ⑧ Ground bar Type GBK21 is installed.
- ⑨ Suitable for use as service equipment when a circuit breaker is used as a main breaker. The main breaker is backfed and requires hold-down kit catalog number Type **CH125RB**.
- ⑩ For ground bar kits, see **Page V1-T1-24**.
- ⑪ Suitable for use as service equipment when a circuit breaker is used as a main breaker. The main breaker is backfed and must be a Type CHB. **The breaker cannot be a Type CH.**
- ⑫ This cover for flush application only (not combination).

Box sizes **Pages V1-T1-29** and **V1-T1-30**.

### Spa Panels



### Contents

<b>Description</b>	<b>Page</b>
Overview .....	V1-T1-2
CH Specialty Products	
Spa Panels	
Surge Panel .....	V1-T1-14
Plug-On Neutral Loadcenter .....	V1-T1-16
Type CH Renovation Loadcenter .....	V1-T1-17
Type CH Retrofit Interior Kits .....	V1-T1-18
CH Loadcenter Options and Accessories .....	V1-T1-21
CH Circuit Breakers .....	V1-T1-31

## CH Specialty Products

### Spa Panels

#### Product Description

Eaton's CH Spa Panels are premium factory-assembled "combination" units that provide ground fault protection, as well as a convenient way to turn spa pumps on and off. The NEC requires that all pool and spa pumps be protected by a ground fault interrupter and a disconnect switch mounted within 10 feet of the tub or the spa.

#### Features

- Two extra circuits for additional loads
- Limited lifetime warranty
- UL Listed
- Tough powder-coated galvanized steel enclosure
- Factory-installed two-pole ground fault circuit interrupter (GFCI)

#### Product Selection

CH Spa Panel



#### Single-Phase Three-Wire—120/240 Vac Insulated/Bondable Neutral—Factory-Installed Ground Bar

Main Ampere Rating	Circuit Breaker Included	Enclosure Type	Type of Trim Included	Box Size	Wire Size Range Cu/Al 60 °C or 75 °C for Main Lugs	Catalog Number
30	CH230GFT	Outdoor	—	5R	#14–1/0	CH30SPAST <sup>①</sup>
40	CH240GFT	Outdoor	—	5R	#14–1/0	CH40SPAST <sup>②</sup>
50	CH250GFT	Outdoor	—	5R	#14–1/0	CH50SPAST <sup>③</sup>
60	CH260GFT	Outdoor	—	5R	#14–1/0	CH60SPAST <sup>④</sup>

#### Notes

- ① Includes a CH230GFT breaker, factory installed, and two extra circuits for convenience.
- ② Includes a CH240GFT breaker, factory installed, and two extra circuits for convenience.
- ③ Includes a CH250GFT breaker, factory installed, and two extra circuits for convenience.
- ④ Includes a CH260GFT breaker, factory installed, and two extra circuits for convenience.

Surge Panel



### Contents

<i>Description</i>	<i>Page</i>
Overview . . . . .	V1-T1-2
CH Specialty Products	
Spa Panels . . . . .	V1-T1-13
Surge Panel	
Plug-On Neutral Loadcenter . . . . .	V1-T1-16
Type CH Renovation Loadcenter . . . . .	V1-T1-17
Type CH Retrofit Interior Kits . . . . .	V1-T1-18
CH Loadcenter Options and Accessories . . . . .	V1-T1-21
CH Circuit Breakers . . . . .	V1-T1-31

### Surge Panel

#### Product Description

Eaton's Type CH Surge Loadcenter includes a factory-mounted and wired surge suppressor device. There is a knockout in the cover that allows the user to view the status indication lights on the surge suppressor. The CH Surge Loadcenter reduces the surge current, helping protect sensitive home electronic equipment.

Save labor by installing a factory-mounted surge protective device.

#### Factory-Installed Surge Protection

- Includes a CHSPT2ULTRA and a two-pole 50 A circuit breaker
- Increases the effectiveness of surge protection due to reduced lead length
- A modified deadfront allows for easy viewing of indicating lights

#### Surge Ready

- Provides a mounting provision for CHSPT2ULTRA
- A modified deadfront allows for easy viewing of indicating lights

#### Product Selection

##### Surge Installed Loadcenters

Ampere Rating	Type	Number of Circuits	Loadcenter Catalog Number	Loadcenter Cover Catalog Number	
				Combination	Surface
225	Convertible	42	CHSUR42N225L ①	CHSUR8LF	CHSUR8LS
225	Convertible ②	42	CHSUR42L225L2 ①	CHSUR8LF	CHSUR8LS
200	Main breaker	42	CHSUR42B200L2 ①	CHSUR8LF	CHSUR8LS
225	Convertible	32	CHSUR32N225K ①	CHSUR8KF	CHSUR8KS
225	Convertible ②	32	CHSUR32L225K ①	CHSUR8KF	CHSUR8KS
200	Main breaker	32	CHSUR32B200K ①	CHSUR8KF	CHSUR8KS
150	Main breaker	32	CHSUR32B150K ①	CHSUR8KF	CHSUR8KS
100	Main breaker	32	CHSUR32B100K ①	CHSUR8KF	CHSUR8KS
125	Convertible ②	24	CHSUR24L125E ①	CHSUR8EF	CHSUR8ES
100	Main breaker	24	CHSUR24B100E ①	CHSUR8EF	CHSUR8ES
200	Convertible	40/40	BRSUR4040N200	Cover included	
200	Main lug	40/40	BRSUR4040L200	Cover included	
200	Main breaker	40/40	BRSUR4040B200	Cover included	
200	Convertible	30/40	BRSUR3040N200	Cover included	
200	Main lug	30/40	BRSUR3040L200	Cover included	
200	Main breaker	30/40	BRSUR3040B200	Cover included	

#### Notes

- ① Order cover separately.
- ② With main lugs installed.

**Surge Ready Loadcenters** (provision only, CHSPT2ULTRA and breaker not included)

Ampere Rating	Type	Number of Circuits	Loadcenter Catalog Number <sup>①</sup>	Loadcenter Cover Catalog Number Combination	Loadcenter Cover Catalog Number Surface
225	Convertible	42	CHEC42N225L	CHSUR8LF	CHSUR8LS
225	Convertible <sup>②</sup>	42	CHEC42L225L	CHSUR8LF	CHSUR8LS
200	Main breaker	42	CHEC42B200L	CHSUR8LF	CHSUR8LS
225	Convertible <sup>②</sup>	32	CHEC32L225K	CHSUR8KF	CHSUR8KS
225	Convertible	32	CHEC32N225K	CHSUR8KF	CHSUR8KS
225	Convertible	32	CHEC32N225R <sup>③</sup>	—	—
200	Main breaker	32	CHEC32B200K	CHSUR8KF	CHSUR8KS
150	Main breaker	32	CHEC32B150K	CHSUR8KF	CHSUR8KS
100	Main breaker	32	CHEC32B100K	CHSUR8KF	CHSUR8KS
125	Convertible <sup>②</sup>	24	CHEC24L125E	CHSUR8EF	CHSUR8ES
100	Main breaker	24	CHEC24B100E	CHSUR8EF	CHSUR8ES

**Technical Data and Specifications****Ratings**

- Loadcenter
  - 25 kAIC main breaker, main lug only, and convertible main breaker/main lug
  - Factory installed or provision for field-installed surge suppressor
  - Top or bottom feed
- Surge protective device (CHSPT2ULTRA)
  - Nominal discharge current: 20 kA ( $I_n$ )
  - Surge current capacity per phase: 108 kA
  - Warranty: \$75,000 connected equipment <sup>④</sup>
  - For further product ratings, see Volume 1, Tab 2.1 Surge Protection

**Notes**

- <sup>①</sup> Order cover separately.
- <sup>②</sup> With main lugs installed.
- <sup>③</sup> Rainproof loadcenters are furnished with hub closure plates. For rainproof hubs, refer to **Page V1-T1-24**.
- <sup>④</sup> For warranty details, visit [www.eaton.com/surgetrap](http://www.eaton.com/surgetrap).

# 1.1

## Loadcenters and Circuit Breakers

### Type CH Loadcenters and Circuit Breakers

1

#### 60-Circuit Plug-On Neutral Loadcenter



### Plug-On Neutral Loadcenter

#### Product Description

Code changes and higher safety standards are leading to more arc fault and ground fault circuit interrupter installations. Eaton offers a unique product solution that enables a direct connection of the breaker to the neutral bar, eliminating the need for wiring a pigtail.

#### Features and Benefits

- Time savings up to 25% per AFCI/GFCI installation
- Eliminates nuisance tripping due to loose pigtail connections
- Clean gutter space
- Easier troubleshooting due to less wiring
- Backed by a limited lifetime warranty

### Contents

<i>Description</i>	<i>Page</i>
Overview .....	V1-T1-2
CH Specialty Products	
Spa Panels .....	V1-T1-13
Surge Panel .....	V1-T1-14
Plug-On Neutral Loadcenter	
Type CH Renovation Loadcenter .....	V1-T1-17
Type CH Retrofit Interior Kits .....	V1-T1-18
CH Loadcenter Options and Accessories .....	V1-T1-21
CH Circuit Breakers .....	V1-T1-31

### Product Selection

#### Main Breaker Plug-On Neutral Loadcenters

Main Breaker Type	Main Ampere Rating	Max. Number 3/4-Inch Poles	Enclosure Type	Wire Size Range for Main Breaker	Catalog Number	Cover Catalog Number	
						Combination	Surface
CSR 25 kAIC	100	24	Indoor	#2–300 kcmil	CH24BPN100E	CH8EF	CH8ES
	200	32	Indoor	#2–300 kcmil	CH32BPN200J	CH8JF	CH8JS
	200	42	Indoor	#2–300 kcmil	CH42BPN200K	CH8KF	CH8KS
	200	60	Indoor	#2–300 kcmil	CH60BPN200N	CH8NF	CH8NS

#### Main Lug Only/Convertible Plug-On Neutral Loadcenters—With Factory Installed Main Lugs

Max. Ampere Rating	Max. Number 3/4-Inch Poles	Enclosure Type	Catalog Number	Wire Size Range for Main Breaker	Cover Catalog Number	
					Combination	Surface
125	24	Indoor	CH24NLPN125E <sup>①</sup>	#6–300 kcmil	CH8NLEF	CH8NLES
225	32	Indoor	CH32NLPN225J	#6–300 kcmil	CH8NLJF	CH8NLJS
225	42	Indoor	CH42NLPN225K	#6–300 kcmil	CH8NLKF	CH8NLKS
225	60	Indoor	CH60NLPN225N	#6–300 kcmil	CH8NLNF	—

#### Note

<sup>①</sup> Maximum 125 A main device.

Renovation Panel

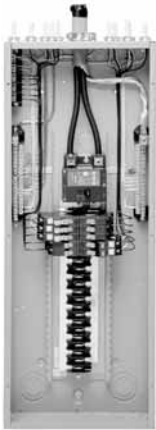

### Type CH Renovation Loadcenter

#### Product Description

Eaton's Renovation Loadcenter is designed for the service contractor. With the addition of a five-circuit terminal block factory mounted in the top left corner of the loadcenter, the service contractor can terminate short-circuit wires instead of having to use expensive wire nuts. Also, the Renovation Loadcenter incorporates a twin-stacked neutral design that places the neutral and ground terminations higher in the loadcenter. Both of these features were added without increasing any size from a standard loadcenter. These features will eliminate the need for wire nuts and make for a much neater installation. There is a provision to field mount a second five-circuit terminal block (RN5TB) in the top right corner of the loadcenter. Choose amongst Eaton's Type CH breaker family for use in the Renovation Panel.

### Contents

<i>Description</i>	<i>Page</i>
Overview .....	V1-T1-2
CH Specialty Products	
Spa Panels .....	V1-T1-13
Surge Panel .....	V1-T1-14
Plug-On Neutral Loadcenter .....	V1-T1-16
Type CH Renovation Loadcenter	
Type CH Retrofit Interior Kits .....	V1-T1-18
CH Loadcenter Options and Accessories .....	V1-T1-21
CH Circuit Breakers .....	V1-T1-31

### Product Selection

#### Single-Phase—Main Circuit Breaker Loadcenters 25 kAIC<sup>①</sup>

#### Single-Phase, Three-Wire—120/240 Vac—Stacked Split Neutral

Main Breaker Type	Main Ampere Rating	Max. Number 3/4-Inch (19.1 mm) of Poles	Enclosure Type	Box Size	Wire Size Range Cu/Al 60 °C or 70 °C for Main Breakers	Loadcenter Catalog Number	Cover Catalog Number <sup>②</sup>	
							Combination	Surface
CH	100	20	Indoor	C	#6–1/0	CH22B100CRN	CH8CFF	CH8CS
CSR	150	32	Indoor	J	#2–300 kcmil	CH32B150JRN	CH8JF	CH8JS
CSR	200	32	Indoor	J	#2–300 kcmil	CH32B200JRN	CH8J	CH8JS
CSR	200	42	Indoor	K	#2–300 kcmil	CH42B200KRN	CH8KF	CH8KS

#### Branch Circuit Breakers (CH)

See **Pages V1-T1-2–V1-T1-12.**

#### Renovation Loadcenter

Description	Catalog Number
Five-circuit terminal block kit	<b>RN5TB</b>
Ground bar kits (two maximum per panel)	(See <b>Page V1-T1-24</b> )

#### Notes

- ① 100 A main breaker is rated 10 kAIC.
  - ② Combination style covers may be used in surface or flush applications.
- All main circuit breaker loadcenters are listed for use as service entrance equipment. Loadcenters are factory-bonded for service entrance applications. Remove bonding strap for separate neutral and ground bars for sub-feed applications.

#### Type CH Retrofit Interior



*Type CH Retrofit Adjustable Interior*



*Type CH Retrofit Interior Collar and Assembly with Trim*

### Contents

<b>Description</b>	<b>Page</b>
Overview . . . . .	V1-T1-2
CH Specialty Products	
Spa Panels . . . . .	V1-T1-13
Surge Panel . . . . .	V1-T1-14
Plug-On Neutral Loadcenter . . . . .	V1-T1-16
Type CH Renovation Loadcenter . . . . .	V1-T1-17
Type CH Retrofit Interior Kits	
CH Loadcenter Options and Accessories . . . . .	V1-T1-21
CH Circuit Breakers . . . . .	V1-T1-31

### Type CH Retrofit Interior Kits

#### Product Description

Eaton’s unique Retrofit Interior allows the customer to cost-effectively and safely upgrade an electrical service without removing the existing enclosure from the wall.

#### Application Description

The Retrofit Interior is designed and tested specifically for renovating an outdated electrical panel in an apartment, a condominium or a single family home. These outdated panels are being recognized by local inspectors and other authorities as a possible hazard.

#### Opportunities to Retrofit

- Single- or three-phase
- Main lug only or main breaker
- Up to 42 circuits
- Up to 225 A interiors, 400 A available upon request
- Available with CH breakers (3/4-inch) with copper bus or BR breakers (1-inch) with aluminum bus
- The minimum lifetime warranty for residential breakers shall be as follows:
  - Limited lifetime warranty on all CH branch breakers and loadcenters
  - Refer to Eaton for complete warranty details

#### Features and Benefits

##### **Upgrading Existing Electrical Infrastructure Is Simple**

- Replaces vintage brands that have hard to find, expensive replacement breakers
- Safely upgrade to arc fault and ground fault breakers to meet current electrical codes
- Maximizes number of circuits available with compact design
- Eco-friendly in asbestos-filled environments
- Exclusive design

##### **Save Time and Money Throughout the Installation**

- Uses existing panel box and wires
- Eliminates expensive and time-consuming drywall/ paint repair
- Saves 2–3 hours of installation time compared to a complete panel changeout
- Eliminates precise measurements with field-adjustable kit

#### Standards and Certifications

Meets 2017 NEC wire bending requirements.

### CH Specialty Product Selection

To select the retrofit kit:

1. From the existing box size determine which retrofit groups are suitable (may be more than one).
2. Use type of interior, number of phases, and type of main to find the selection chart.
3. Select part number from chart (if main breaker, replace XXX with specific amp rating).

#### How to Order:

1. Measure the existing panel enclosure to determine appropriate kits for your project.
2. Match the existing dimensions with the table below to obtain the correct catalog number.
3. Order your retrofit kit from a local Eaton authorized distributor.

Need assistance or can't find retrofit to fit existing enclosure?

Phone:  
800-330-6479

E-mail:  
FlexCenterLincoln@Eaton.com

Locate an Eaton Certified Contractor at  
EatonCertified.com

### Retrofit Interior Kit Specifications

Catalog Number ①	Cover ②	Existing Enclosure Parameters—Inches (mm)				Phase	Main	Bus	Amperes ③	Spaces / Circuits	UL 67 Listed
		Minimum Depth	Maximum Depth	Minimum Width	Minimum Height						
<b>CH Retrofit Interiors and Covers</b>											
RWCH6L125N	CRWCH6ML****	3.13 (79.5)	4.13 (104.9)	7.00 (177.8)	10.00 (254.0)	Single	MLO	CH	125	6	No
RSCH10B125N	CRWCH12ML****	3.50 (88.9)	4.50 (114.3)	8.50 (215.9)	16.50 (419.1)	Single	MCB	CH	125	10	No
RSCH12L125N	CRWCH12ML****	3.50 (88.9)	4.50 (114.3)	8.50 (215.9)	16.50 (419.1)	Single	MLO	CH	125	12	No
RACH22B125_	CRACH24ML****	3.75 (95.3)	4.25 (108.0)	13.00 (330.2)	21.00 (533.4)	Single	MCB	CH	125	22	No
RACH24L125_	CRACH24ML****	3.75 (95.3)	4.25 (108.0)	13.00 (330.2)	21.00 (533.4)	Single	MLO	CH	125	24	No
RBCH24B200_	CRBCH24CS****	3.75 (95.3)	6.00 (152.4)	13.00 (330.2)	29.00 (736.6)	Single	MCB	CH	200	24	No
RBCH32L200_	CRBCH32ML****	3.75 (95.3)	6.00 (152.4)	13.00 (330.2)	29.00 (736.6)	Single	MLO	CH	200	32	No
RCCH32B200_	CRBCH32CS****	3.75 (95.3)	6.00 (152.4)	13.00 (330.2)	34.00 (863.6)	Single	MCB	CH	200	32	No

### Complete Assembly

**Note:** For complete assembly, interior and cover need to be ordered separately.

#### Adjustable Interior

- Factory installed ground and neutral bars positioned to accept existing wires
- Field adjustable depth matches existing panel box
- Adjustable height enables optional placement of the interior
- Field bondable for service entrance options



Adjustable Interior

#### Standard Trim and Collar

- Standard trim matches new interior
- New circuit directory for updated labeling
- Oversized collar eliminates expensive wall/paint repair



Collar and Assembly with Trim

#### Notes

① Catalog numbers shown with “\_” at the end need one of the following suffixes to denote depth:

J = 3.75–4.25  
K = 4.25–5.00  
L = 5.00–6.00

Example: RBCH24B200J would signify an interior set with a depth range of 3.75 to 4.25 inches.

② \*\*\*\*Denotes characters in the catalog number that relate to overall cover size. Example: CRWCH6ML2620 would signify a cover 26.00 inches H x 20.00 inches W, or CRBCH24CS3324 would be 33.00 inches H x 24.00 inches W.

③ Amperes for MB panels is maximum; catalog number will reflect actual amperage of breaker included.

For UL applications, maximum cover sizes may apply.



# 1.1

## Loadcenters and Circuit Breakers

### Type CH Loadcenters and Circuit Breakers

#### 1

#### Non-Metallic Loadcenter

##### Single-Phase—Main Lug Loadcenters, Non-Metallic

2460SNM



##### Single-Phase Three-Wire—120/240 Vac—Insulated/Bondable Neutral

Main Ampere Rating	Maximum Number 1-Inch (25.4 mm)		Enclosure Type	Trim Type	Box Size	Wire Size Range Cu/Al 60 °C or 75 °C for Main Lugs	Loadcenter Catalog Number
	Spaces	Circuits					
40 <sup>①</sup>	2	4	Indoor	Flush (no door)	2	<sup>②</sup>	TT120FLGNM <sup>②③</sup>
	2	4	Indoor	Surface (no door)	2		TT120SLGNM <sup>②③</sup>
60	2	4	Indoor	Flush (no door)	2	#14–2	2460FNM
	2	4	Indoor	Surface (no door)	2		2460SNM
	2	4	Indoor	Flush (no door)	2		2460FGNM <sup>③</sup>
	2	4	Indoor	Surface (no door)	2		2460SGNM <sup>③</sup>
	2	4	Indoor	Surface (no door)	2		2460SGNM <sup>③</sup>
	2	4	Outdoor	—	—		2460RNM-A2

#### Notes

- ① Suitable for use as service equipment when not more than six main disconnecting means are provided and when not used as a lighting and appliance panelboard.
- ② This device has no main lugs. A Type BR or BD breaker is required to be backed to supply power to branch breakers. This device is single-phase 120 Vac only. With the use of three Type BR breakers, there are two branch circuits available. With the use of three Type BD breakers, there are five branch circuits available.
- ③ Includes GB4NM ground bar.

### Options and Accessories—Mechanical Interlocks

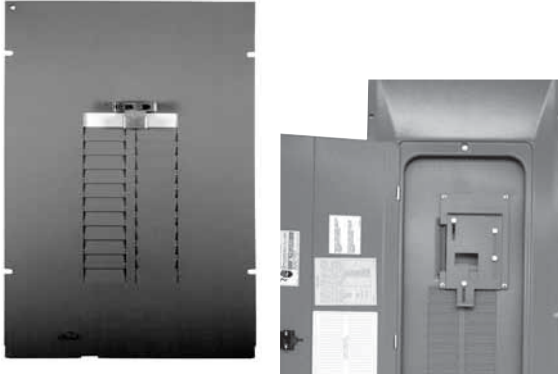

### Contents

<b>Description</b>	<b>Page</b>
Overview .....	V1-T1-2
CH Specialty Products	
Spa Panels .....	V1-T1-13
Surge Panel .....	V1-T1-14
Plug-On Neutral Loadcenter .....	V1-T1-16
Type CH Renovation Loadcenter .....	V1-T1-17
Type CH Retrofit Interior Kits .....	V1-T1-18
CH Loadcenter Options and Accessories	
Technical Data and Specifications .....	V1-T1-26
Dimensions .....	V1-T1-29
CH Circuit Breakers .....	V1-T1-31

## CH Loadcenter Options and Accessories

### Product Selection

#### CHSF2125



#### Field Installation and Parts

##### Description

Sub-feed lug blocks—two-pole, 125 A, 3/4-inch (19.1 mm) spaces needed  
 Sub-feed lug blocks—three-pole, 125 A, 3/4-inch (19.1 mm) spaces needed  
 Neutral/ground lug—add-on neutral or ground lug

##### Ordering Quantity <sup>①</sup>

##### Catalog Number

1      **CHSF2125**  
 1      **CHSF3125**  
 1      **NL20**  
 1      **NL30**  
 1      **NL300**

#### CHSF3125



Filler plates—3/4-inch (19.1 mm) space circuit breaker space  
 CSR main circuit breaker filler plate (with hardware)  
 Door lock—12–42 circuits, and 100–225 A  
 Sandlewood spray paint  
 ANSI-61 light gray touchup paint for outdoor loadcenters

25      **CHFP**  
 1      **CSRFP**  
 1      **TDL**  
 1      **SPCSW**

#### CHFP



Isolated neutral assembly (computer circuits)  
 Circuit directory—adhesive backed  
 Cover screws

1      **BINA**  
 10      **TCD**  
 25      **LCCS**

#### TDL



Cover replacement latch 14-5/16 inch (363.55 mm) wide loadcenters only  
 Circuit marking strip (next to breakers)  
 Circuit identification label (preprinted breaker labels next to breakers)

1      **CHRLS**  
 10      **CHMS**  
 25      **CHBL**

#### BINA



Series rated caution label  
 Branch circuit numbering strip  
 Bonding strap with screw  
 CH plug-on neutral ground bonding strap

25      **SRL**  
 20      **CHNS**  
 1      **BSSUSE**  
 1      **BSCHPON**

#### Note

<sup>①</sup> Must be purchased in multiples of ordering quantities indicated.

# 1.1

## Loadcenters and Circuit Breakers

### Type CH Loadcenters and Circuit Breakers

1

#### Main Breaker Kits

Maximum Main Ampere Rating	Catalog Number	
	25 kAIC	35 kAIC
100	CSR2100N	CSH2100N
150	CSR2150N	CSH2150N
200	CSR2200N	CSH2200N
225	CSR2225N	CSH2225N

#### Main Lug Kits

Maximum Main Ampere Rating	Catalog Number
125	CHL125N
225	CHL225N



#### Main Breaker Kits

Breaker Ampere Rating	Lug Size	Catalog Number
100	#2–300 kcmil	CSR2100
150	#2–300 kcmil	CSR2150N
200	#2–300 kcmil	CSR2200N
225	#2–300 kcmil	CSR2225N

#### Mechanical Interlock Covers

Covers mechanically interlock two breakers. Type A covers interlock two CH breakers mounted across from one another. Type B covers interlock a main Type CSR breaker with a Type CH.

#### Mechanical Interlocks

	Type	Fits Loadcenter Catalog Numbers	Mechanical Interlock Trim/Deadfront Catalog Numbers	
			Flush	Surface
<b>CH8BRM Type A</b> 	A	CH12L125B	CH8BFM	CH8BSM
		CH16L125B		
		CH12L3125B		
		CH14B100B		
		CH20L125C	CH8CFM	CH8CSM
		CH24L125C		
		CH18L3125C		
		CH24L3125C		
		CH22B100C		
		CH22N100C		
		CH24L150D	CH8DFM	CH8DSM
		CH32L150D		
		CH24L3225D		
		CH30L3150D		
		CH42L225G	CH8GFM	CH8GSM
		CH42L3225G		
Inner cover of Box B raintight	—	CH8BRM		
Inner cover of Box C raintight	—	CH8CRM		
<b>Indoor</b>				
<b>CH8EFM Type B</b> 	B	CH24B150E	CH8EFM	CH8ESM
		CH24B200E		
		CH24BPN200E		
		CH32B150J	CH8JFM	CH8JSM
		CH32B200J		
		CH3242B200J		
		CH32BPN200J		
		CH32N200J		
		CH32B225J		
		CH42B200K	CH8KFM	CH8KSM
		CH42N200K		
		CH42BPN200K		
		CH42B225K		
		CH60BPN200N	CH8NFM	—

### CH8EFM Type B



### Mechanical Interlocks, continued

Type	Fits Loadcenter Catalog Numbers	Mechanical Interlock Trim/Deadfront Catalog Numbers		
		Flush	Surface	
<b>Outdoor</b>				
B	CH8B150RF	CH3RDF7M	—	
	CH8B200RF			
	CH8N200RF			
	CH12B200RF			
	CH24B150R			
	CH24B200R			
	CH32B150R	CH3RDF9M	—	
	CH32B200R			
	CH32N200R			
	CH32B225R			
	CH42B200R	CH3RDF10M	—	
	CH42N200R			
	CH42B225R			
	<b>Next Generation Power Center</b>			
B	CHPC32B150L	CHPC8B32LFM	—	
	CHPC32B200L			
	CHPC32N200L			
	CHPC42B150L	CHPC8B42LFM	—	
	CHPC42B200L			
	CHPC42N200L			
	CHPC32B125TR	CH3RDF15M	—	
	CHPC32B150TR			
	CHPC32B200TR			
	CHPC32N200TR			
	CHPC42B150TR	CH3RDF16M	—	
	CHPC42B200TR			
	CHPC42N200TR			
	CHPC32B150TR	CH3RDF17M	—	
	CHPC32B200TR			
	CHPC42B200BR	CH3RDF18M	—	
	<b>Vintage <sup>①</sup></b>			
		CH20JJM200	CH7JFREPLM	—
	CH24JJM150			
	CH30JJM150			
	CH30JJM200			
	CH30JJM150H			
	CH3040JMM200			
	CH304JJM150			
	CH304JJM200			
	CH304JJM200H			
	CH30KKM225	CH7KKFREPLM	—	
	CH40KKM200H			
	CH40KKM225			
	CH40KKM200H			
	CH40KKM225H			
	CH304KKM200			
	CH304KKM200H			
	CH304LLM225	CH7LLFREPLM	—	
	CH424LLM225H			

**Note**

<sup>①</sup> If vintage part number does not match exactly, the cover may not fit. Simple variations such as an "N" at the end of the part number contain minor design variations that will prevent our cover from working with that particular loadcenter.

# 1.1

## Loadcenters and Circuit Breakers

### Type CH Loadcenters and Circuit Breakers

1

#### DS100H1



#### Field Installation Rainproof Conduit Hubs

Description	Conduit Size Inches (mm)	Ordering Quantity <sup>①</sup>	Catalog Number
Group 1—for use with 70, 100 and 125 A MLO and MCB loadcenters and circuit breaker enclosures	0.75 (19.1)	1	DS075H1
	1.00 (25.4)	1	DS100H1
	1.25 (31.8)	1	DS125H1
	1.50 (38.1)	1	DS150H1
	2.00 (50.8)	1	DS200H1
Group 2—for use with 150, 200 and 225 A MLO and MCB loadcenters and circuit breaker enclosures	2.00 (50.8)	1	DS200H2
	2.50 (63.5)	1	DS250H2
	3.00 (76.2)	1	DS300H2
Adapter kit—allows installing a Group 1 hub on devices arranged for Group 2 hubs	—	1	DS900AP
Group 1—small blank hub closure plate	—	1	DS900CP1
Group 2—large blank hub closure plate	—	1	DS900CP2

#### GBK14



#### Ground Bar Kits

Description (See Legend)	Length Inches (mm)	Ordering Quantity <sup>②</sup>	Catalog Number
●○○○○●	2.54 (64.5)	1	GBK5 <sup>②</sup>
●○○○○●■	3.59 (91.2)	1	GBK520 <sup>②</sup>
●○○○○●○○○○○	4.29 (109.0)	1	GBK10 <sup>②</sup>
●○○○○●○○○○○■	5.34 (135.6)	1	GBK1020 <sup>②</sup>
●○○○○●○○○○○■	4.61 (117.1)	1	GBK13 <sup>②</sup>
●○○○○●○○○○○	5.69 (144.5)	1	GBK14 <sup>②</sup>
●○○○○●○○○○○■	6.74 (171.2)	1	GBK1420 <sup>②</sup>
●○○○○●○○○○○	8.14 (206.8)	1	GBK21 <sup>②</sup>
●○○○○●○○○○○■	9.19 (233.4)	1	GBK2120 <sup>②</sup>
○○○○○○●○○○○○	7.94 (201.7)	1	CH9GP21 <sup>③④</sup>

#### Ground Bar Legend

- = (3) #14–#10 Cu/Al or (1) #14–#4 Cu/Al
- = (1) #6–2/0 Cu/Al
- ▣ = (1) 1/0–14 or (3) #10–12 Cu/Al
- ◐ = (1) #14–1/0 Cu/Al or (3) #14–#10 Cu/Al
- = Mounting hole

#### Grounded “B” Phase Adapters

Maximum Amperes	Three-Phase Loadcenter Types of Panels	Kit Catalog Number <sup>⑤</sup>
125	12–32 circuit main lug	CHGRD1
225	Main lug and CHH main breaker panels	CHGRD2
	CC main CB panels	CHGRD3

#### Neutral Bar Accessories

Description	Catalog Number <sup>⑤</sup>
Replacement neutral for all B and C type boxes	CHN125C
Replacement neutral for all D type boxes	CHN125D
Replacement neutral for all E, G, J, K and L type boxes	CHN225L
Isolated Neutral Assembly (computer circuits)	BINA

#### Notes

- ① Must be purchased in multiples of ordering quantities indicated.
- ② Distance between mounting holes is 1-3/4 inches (44.5 mm).
- ③ For single- and three-phase 400 A loadcenters.
- ④ Distance between mounting holes is 2-13/32 inches.
- ⑤ Cannot be used in Safety Breaker Panels. Classic Plus Panels only.

### Decorator Cover Accessory

- For easy use with CH loadcenters mounted in living space
- Easily wallpapered or painted to match any decor
- Loadcenter accessory—exclusively from Eaton



*Now you see it ...*

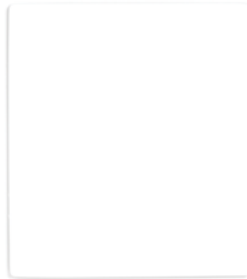

*... Now you don't.*

### Decorator Cover Accessory

Catalog Number	Existing CH Loadcenter Cover
CH8BF	CH8KDNB
CH8CF	CH8KDNC
CH8DF/EF	CH8KDND
CH8GF/JF	CH8KDNJ
CH8KF	CH8KDNK

### Loadcenter Goof Collars

Don't let an ugly drywall problem ruin a beautiful electrical installation.

Eaton's Goof Collar is designed to cover gaps between the finished drywall and loadcenter enclosure. This is often necessary when upgrading the electrical service and the drywall surrounding the panel is damaged. The collar allows 2 inches of overhang beyond the standard flush trim.



*Before*



*After*

### CH Goof Collars

Inches (mm)		Catalog Number	
Height	Width	Loadcenter Cover	Goof Collar
21.00 (533.4)	19.00 (482.6)	CH8BF	CH8BFC1921
26.00 (660.4)	19.00 (482.6)	CH8CF	CH8CFC1926
34.00 (863.6)	19.00 (482.6)	CH8DF	CH8DFC1934
		CH8EF	
		CHSUR8EF	
39.00 (990.6)	19.00 (482.6)	CH8GF	CH8JFC1939
		CH8JF	
42.00 (1066.8)	19.00 (482.6)	CH8KF	CH8KFC1942
		CHSUR8KF	
44.00 (1117.6)	19.00 (482.6)	CH8LF	CH8LFC1944
		CHSUR8LF	

**Technical Data and Specifications****General**

- A. The Contractor shall furnish and install loadcenters incorporating circuit breakers of the number, rating and type as specified herein and as shown on the contract drawings.
- B. The loadcenter and all components shall be designed, manufactured and tested in accordance with the latest applicable standards of UL and NEMA including:
  1. UL 67—standards for panelboards
  2. UL 50—standards for cabinets and boxes
  3. UL 489—standards for molded case circuit breakers
  4. Federal Spec Classification W-C 375
  5. UL 1699—all fault interrupting

**Qualifications**

- A. The manufacturer of the loadcenter shall be the manufacturer of the circuit breaker within the load center. All breakers shall be full size.
- B. For the equipment specified herein, the manufacturer shall be ISO® 9000 certified.
- C. The manufacturer of this equipment shall have produced similar electrical equipment for a minimum period of seven (7) years.

**Manufacturers**

- A. Eaton

**Ratings**

- A. Loadcenters shall be rated for 240 Vac and shall have short-circuit ratings as shown on the drawings or as herein scheduled, but not less than 10,000 amperes rms symmetrical.
- B. Breakers shall be full size and a minimum of 125 A frame. Breakers 10 –125 A trip size shall take up the same pole spacing.
- C. Loadcenters shall be labeled with a UL short-circuit rating. When series ratings are applied with integral or remote devices, a label shall be provided. Series ratings shall cover all trip ratings of installed frames. It shall state the conditions of the UL series ratings including:
  1. Size and type of upstream device.
  2. Branch devices that can be used.
  3. UL series short-circuit rating.

**Construction**

- A. All interiors, with the exception of the branch circuit breakers shall be completely factory assembled with main breakers, main lugs or no main device.
- B. Interiors shall be so designed that circuit breakers can be replaced without disturbing adjacent units and without removing the main bus connectors and shall be so designed that circuits may be changed without machining, drilling or tapping.
- C. Physical means must be provided to prevent the installation of more overcurrent devices than that number for which the enclosure was designed. Full size breakers are required.

**Bus**

- A. Busbars for the main and cross connectors shall be of silver flash plated copper construction in accordance with UL standards. Bussing shall be braced to 65 kAIC.
- B. Neutral bussing shall have a suitable lug for each outgoing feeder requiring a neutral connection of same ampacity as branch.

**Wiring/Termination**

- A. All wire connectors and terminals shall be of the anti-turn solderless type and suitable for copper or aluminum wire of the sizes indicated. All connectors shall meet the "Requirements for Wire Connectors and Soldering Lugs" UL 486B.
- B. All loadcenters where marked shall be suitable for use with 60/75 °C rated wire.

**Circuit Breakers**

- A. Circuit breakers shall be molded case type, 3/4-inch (19.1 mm) wide per pole. Multipole circuit breakers shall be of a stack pole design to provide electrical phase isolation and have an internal common trip.
- B. Each pole of the circuit breaker will have inverse time delay overload and instantaneous short-circuit protection by means of both thermal and magnetic sensors. Circuit breakers shall be quick-make/quick-break.
- C. The circuit breaker calibration shall not be affected by environmental changes in relative humidity. Breakers shall be calibrated after assembly.
- D. All circuit breakers shall be operated by a toggle-type handle and multipole circuit breakers shall have an internal common trip mechanism. The circuit breakers shall incorporate trip mechanisms that are mechanically trip-free from the handle. The handle position shall provide good visual trip indication.
- E. Contacts shall be of non-welding silver alloy.
- F. All branch breaker handles shall be of a different color than the case of the breaker.
- G. All terminals shall be listed for use with copper or aluminum conductors. Terminals shall be of the box lug design. The terminals shall meet UL 486B requirements and shall be suitable for use with either 60 °C or 75 °C wire.
- H. Breakers shall be SWD rated and/or HACR rated as required.
- I. Arc fault interrupting circuit breakers, (AFC), shall be provided on all 15 and 20 A single-phase 120/240 Vac circuits except those indicated as remote controlled breakers. AFC breakers shall be "Classified for mitigating the effects of arcing faults," or conforming to UL Standard 1699 and as defined by per Article 210.12 Section A of the NEC Code.

**Enclosures**

- A. Loadcenters shall have NEMA 1 general purpose or NEMA 3R rainproof enclosures as indicated on the drawings and shall be surface or flush mounted except where noted.
- B. For indoor applications, enclosures shall be rated NEMA 1. Enclosures shall be manufactured from cold-rolled code-gauge sheet steel having multiple knockouts and painted per paint specification. For outdoor applications, enclosures shall be rated NEMA 3R. Enclosures shall be manufactured from galvanized steel which shall be painted per the painted as specified. Enclosures shall be of sufficient size to meet or exceed NEC wire bending space.
- C. The cover shall have an easy adjustment feature for flush applications.
- D. Boxes shall be factory assembled into a single rigid structure.
- E. Provide circuit breaker marking labels and directories.

**Finish**

- A. Boxes and trims shall be finished with a high scratch-resistant aesthetically pleasing finish. The finish shall be polyurethane coating electrostatically applied to a thickness of 1.8 to 2 mils.

All loadcenters shall be provided with provisions for accepting a paintable or wall paperable decorator accessory cover. Where loadcenters are installed in living areas, provide manufacturer designed and tested decorator cover kits.



## CH Loadcenters

**Description****Service**

Single-phase, three-wire, 120/240 Vac

Three-phase, four-wire, 208Y/120 Vac

Three-phase, three-wire, 240 V corner grounded delta

Three-phase, three-wire, 240 Vac delta

**Short-Circuit Current Rating**

10 kAIC: All single- and three-phase loadcenters 40–400 A, 2–42 circuits except when series ratings are applied

35 kAIC available on convertible units using CSH main breaker

25 kAIC: All factory-installed main breakers single-phase loadcenters rated 150–225 A using Type CSR main breakers

42 and 100 kAIC are available on some styles: single-phase and three-phase

**Main Breaker/Main Lug Loadcenters**

Single-phase

Three-phase

Main breaker: 100, 125, 150, 200, 225, 400 A

Main breaker: 150, 200, 225, 300, 400 A

Main lugs: 40, 70, 125, 150, 200, 225, 400 A

Main lugs: 125, 150, 200, 225, 400 A

**Convertible Loadcenters**

Main breaker or main lugs: single-phase up to 225 A

**Branch Breakers**

Type CH: 10–150 A. Single-, two- and three-pole. Selected amperages available in shunt trip, HACR and switching duty

Type CH-AFCI arc fault circuit interrupter

Ground fault circuit interrupters: 15–60 A

Type CHP: 10–125 A. Single-, two- and three-pole. three-position commercial trip

Type CH-HID: 15–30 A. Single-, two- and three-pole

Selected amperages available in HACR switching duty

CH-HM high magnetic

Type CHP-HID: 15–30 A. Single-, two- and three-pole

CH-M50 high ambient

Type CHP-GFCI: 15–30 A. Single-pole ground fault breakers

**Enclosures**

NEMA® Type 1 indoor

NEMA Type 3R outdoor

**Loadcenter and Breaker Accessories**

Branch circuit breaker:

Complete line of ground bar kits 5, 10, 14 and 21 circuits, some with additional #2/0 lugs

Auxiliary components

Each terminal will accommodate: (3) #14–#10 Cu/Al or (1) #14–#4 Cu/Al

Hold-down kits

Sub-feed lugs 125, 150 A—two- and three-pole

Handle ties

Shunt trips

Lockoffs

Universal rainproof conduit hubs Group One: 3/4, 1, 1-1/4, 1-1/2, 2 inches (19.1, 25.4, 31.8, 38.1, 50.8 mm)

Lockdogs

Group Two: 2, 2-1/2, 3 inches (50.8, 63.5, 76.2 mm)

Adapter plate

**Bussing**

Silver flash plated copper bus is a standard feature

### Dimensions

Approximate Dimensions in Inches (mm)

#### Residential/Commercial/Unit Enclosure—Box Sizes

**Note:** Box sizes do not include covers/fronts.

#### Residential Loadcenters

Box Size	Height	Width	Depth
<b>NEMA Type 1 Indoor</b>			
5	9.50 (241.3)	4.50 (114.3)	3.13 (79.4)
6	11.38 (288.9)	6.88 (174.6)	3.39 (86.1)
7	13.00 (330.2)	11.00 (279.4)	3.69 (93.7)
B	16.75 (425.5)	14.31 (363.5)	3.88 (98.4)
C	21.00 (533.4)	14.31 (363.5)	3.88 (98.4)
D	29.13 (739.8)	14.31 (363.5)	3.88 (98.4)
E	29.13 (739.8)	14.31 (363.5)	3.88 (98.4)
G	34.13 (866.8)	14.31 (363.5)	3.88 (98.4)
J	34.13 (866.8)	14.31 (363.5)	3.88 (98.4)
K	37.00 (939.8)	14.31 (363.5)	3.88 (98.4)
L	39.00 (990.6)	14.31 (363.5)	3.88 (98.4)
N	45.00 (1143.0)	14.31 (363.5)	3.88 (98.4)
<b>NEMA Type 3R Outdoor</b>			
5R	9.50 (241.3)	4.50 (114.3)	3.13 (79.4)
6R	11.75 (298.5)	6.50 (165.1)	4.50 (114.3)
7R	13.00 (330.2)	11.00 (279.4)	3.69 (93.7)
B	16.75 (425.5)	14.31 (363.5)	5.19 (131.8)
C	21.00 (533.4)	14.31 (363.5)	5.19 (131.8)
D	29.13 (739.8)	14.31 (363.5)	5.19 (131.8)
E	29.13 (739.8)	14.31 (363.5)	5.19 (131.8)
G	34.13 (866.8)	14.31 (363.5)	5.19 (131.8)
J	34.13 (866.8)	14.31 (363.5)	5.19 (131.8)
K	37.00 (939.8)	14.31 (363.5)	5.19 (131.8)
L	39.00 (990.6)	14.31 (363.5)	5.19 (131.8)

#### Commercial Loadcenters

Box Size	Height	Width	Depth
<b>NEMA Type 1 Indoor</b>			
P	54.38 (1381.1)	21.00 (533.4)	6.00 (152.4)
PM	62.63 (1590.7)	21.00 (533.4)	6.00 (152.4)

#### Types ECB and ECC Unit Enclosures

Height	Width	Depth
<b>NEMA Type 1 Indoor</b>		
23.25 (590.6)	8.88 (225.4)	4.50 (114.3)
<b>NEMA Type 3R Outdoor</b>		
23.69 (601.7)	9.31 (236.5)	5.44 (138.1)

#### Residential Loadcenter Knockout

Residential NEMA Type 1 Indoor and NEMA Type 3R Outdoor Enclosures.

#### Knockouts for Box Sizes 5, 6, 7, 5R, 6R, 7R

Code	Diameter			
A	0.50 (12.7)	—	—	—
B	0.50 (12.7)	0.75 (19.1)	—	—
C	0.50 (12.7)	0.75 (19.1)	1.00 (25.4)	—
D	0.50 (12.7)	0.75 (19.1)	1.00 (25.4)	1.25 (31.8)
E	0.75 (19.1)	1.00 (25.4)	1.25 (31.8)	—
F	0.75 (19.1)	1.00 (25.4)	1.25 (31.8)	1.50 (38.1)
G	1.00 (25.4)	1.25 (31.8)	1.50 (38.1)	—
H	1.00 (25.4)	1.25 (31.8)	1.50 (38.1)	2.00 (50.8)
I	1.25 (31.8)	1.50 (38.1)	2.00 (50.8)	—

#### Knockout Positions

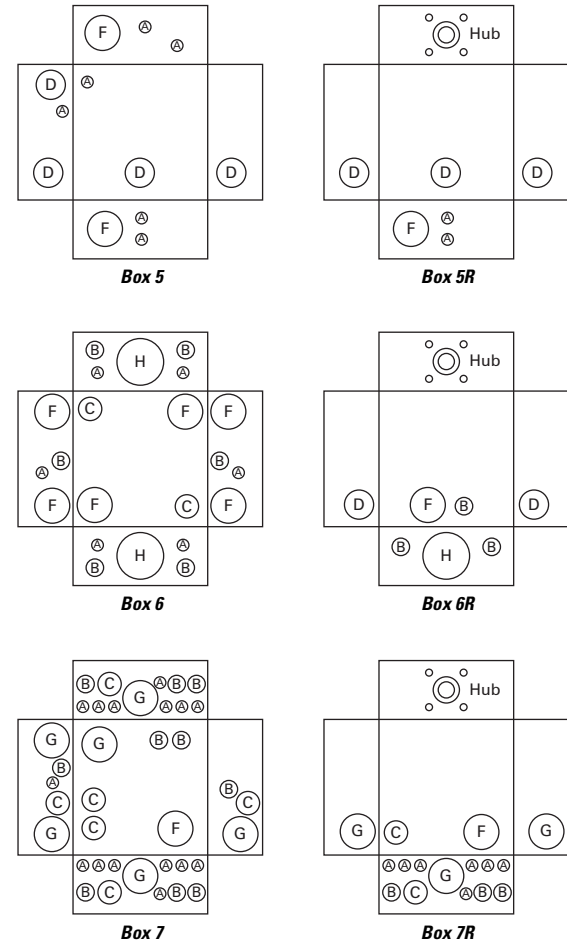

# 1.1

## Loadcenters and Circuit Breakers

### Type CH Loadcenters and Circuit Breakers

1

Approximate Dimensions in Inches (mm)

#### Residential and Commercial Loadcenter Knockout

Residential NEMA Type 1 indoor and NEMA Type 3R outdoor enclosures.

#### Knockouts for Box Sizes 8, 8R, P, PM, B, C, D, E, G, J, K, L, N and Outdoor Boxes 12–60 Circuits

Code	Diameter				
a	0.75 (19.1)	—	—	—	—
b	0.50 (12.7)	0.75 (19.1)	—	—	—
c	0.50 (12.7)	—	—	—	—
d	1.00 (25.4)	1.25 (31.8)	1.50 (38.1)	2.00 (50.8)	2.50 (63.5)
e	1.25 (31.8)	1.50 (38.1)	2.00 (50.8)	2.50 (63.5)	—
f	0.75 (19.1)	1.25 (31.8)	1.50 (38.1)	2.00 (50.8)	—
g	0.50 (12.7)	0.75 (19.1)	1.00 (25.4)	—	—
h	1.50 (38.1)	2.00 (50.8)	2.50 (63.5)	—	—
i	0.50 (12.7)	0.75 (19.1)	1.00 (25.4)	1.25 (31.8)	1.50 (38.1)
j	1.00 (25.4)	1.25 (31.8)	1.50 (38.1)	—	—
k	1.25 (31.8)	1.50 (38.1)	2.00 (50.8)	—	—
m	0.75 (19.1)	1.00 (25.4)	1.25 (31.8)	1.50 (38.1)	2.00 (50.8)
n	0.75 (19.1)	1.00 (25.4)	1.25 (31.8)	1.50 (38.1)	—
p	2.00 (50.8)	2.50 (63.5)	—	—	—

#### Knockout Diagram

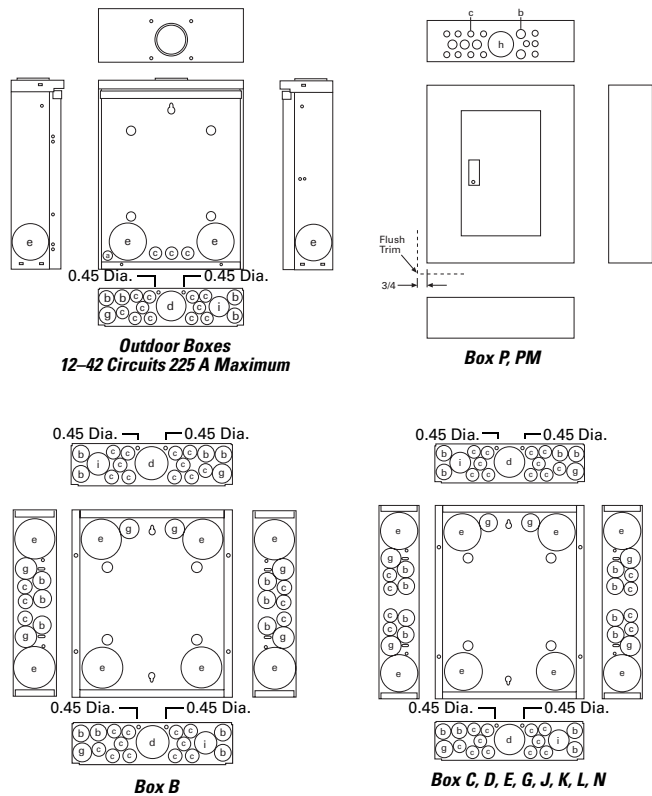

#### Type ECB and ECC Unit Enclosure Knockout

Code	Diameter				
<b>NEMA Type 1 Indoor (Flush and Surface Trims)</b>					
A	0.50 (12.7)	—	—	—	—
B	1.25 (31.8)	1.50 (38.1)	1.75 (44.5)	2.00 (50.8)	2.50 (63.5)
<b>NEMA Type 3R Outdoor</b>					
A	0.50 (12.7)	—	—	—	—
B	1.25 (31.8)	1.50 (38.1)	1.75 (44.5)	2.00 (50.8)	2.50 (63.5)

#### NEMA Type 1—Indoor

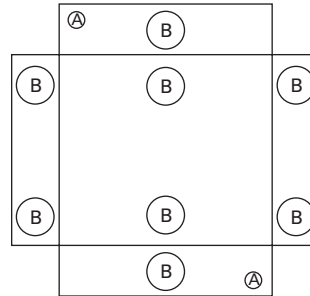

#### NEMA Type 3R—Outdoor

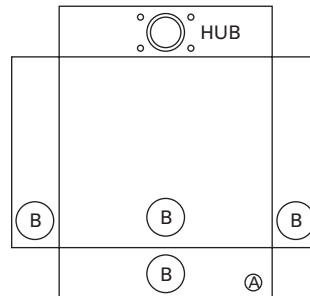

### Plug-On Circuit Breakers



## CH Circuit Breakers

### Product Description

Quick-make, quick-break switch mechanism combined with inverse time element tripping operation and trip-free handle design. Type CH circuit breakers trip to the OFF position, eliminating nuisance callbacks. The CHF family also includes a trip flag to differentiate between a trip and the breaker being turned off. The thermal-magnetic trip curve avoids nuisance tripping on mild overloads while reacting almost instantaneously to severe short-circuit conditions. Multipole breakers have internal common trip connection to operate all poles simultaneously. Handles are marked with ON-OFF indication and ampere rating of the breaker.

### Special Application Plug-On Circuit Breakers—Type CH 10 kAIC 120 Vac and 120/240 Vac

#### Branch Feeder Type Arc Fault Circuit Breakers

A branch feeder type arc fault circuit interrupter is a device intended to mitigate high current arcing faults in the complete circuit, including connected cords. High current arcing faults can occur from line to neutral or line to ground. These arcing faults are in parallel with the load and produce the most energy of all arcing faults.

The branch feeder type AFCI is required in the 1999 and 2002 National Electrical Code.

The Combination Type AFCI is required in all subsequent editions of the National Electrical Code.

#### Combination Type Arc Fault Circuit Breakers

A combination type arc fault circuit interrupter is a device that offers mitigation of high current arcing faults in the complete circuit, including connected cords. In addition it provides direct detection of persistent low current arcing faults down to 5 amps with associated mitigation of fire hazards in the cords connected to the outlets. High current arcing faults can occur from line to neutral or line to ground. These arcing faults are in parallel with the load and produce the most energy of all arcing faults. The current level of low current arcing faults is limited by the load.

#### Ground Fault Circuit Breakers—Ground Fault Application Notes

Single-pole Type CHGFI are designed for use in two-wire, 120 Vac circuits. The diagram on Page V1-T1-40 shows a typical wiring configuration.

## Contents

### Description

	<i>Page</i>
Overview .....	V1-T1-2
CH Specialty Products .....	V1-T1-13
CH Loadcenter Options and Accessories .....	V1-T1-21
CH Circuit Breakers	
Product Selection .....	V1-T1-32
Options and Accessories .....	V1-T1-38
Technical Data and Specifications .....	V1-T1-40
Wiring Diagrams .....	V1-T1-40

Two-pole Type CHGFIs are designed for use in three-wire, 120/240 Vac circuits, 120 Vac multiwire circuits employing common, neutral and two-wire, 240 Vac circuits obtained from a 120/240 Vac source.

Diagrams on Page V1-T1-40 illustrate typical wiring configurations for 120/240 Vac multiwire circuits.

The diagram on Page V1-T1-40 depicts a 240 Vac, two-wire circuit. Note the "panel neutral" conductor connects to the neutral bar,

even though the neutral is not included in the load circuit. This connection is necessary to supply a 120 Vac power source to the ground fault sensing circuit.

The figures are shown with a 120/240 Vac, single-phase, three-wire power source, but are also applicable to a 120/208 Vac, three-phase, four-wire power supply. For all figures, the electrical operation of the Type CHGFI is not affected by the equipment ground.

### Features

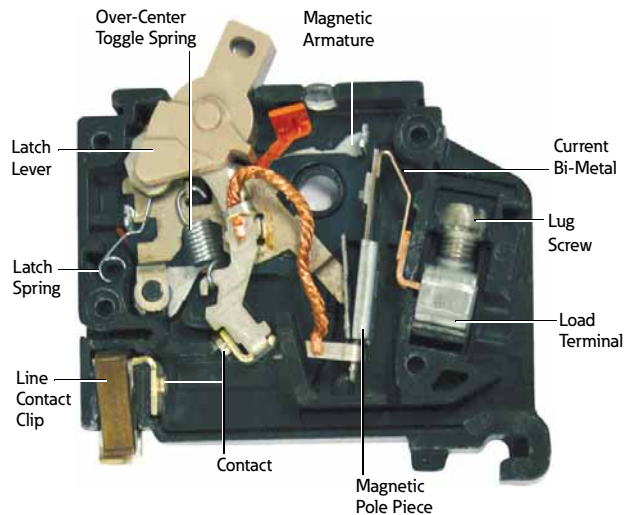

# 1.1

## Loadcenters and Circuit Breakers

### Type CH Loadcenters and Circuit Breakers

1



#### Product Selection

10 kAIC, 120 Vac, 120/240 Vac and 240 Vac

##### Type CH Plug-On Circuit Breakers





#### Type CH Breakers, 3/4-Inch (19.1 mm) per Pole 120, 120/240 or 240 Vac, 10 kAIC

Ampere Rating	Wire Size Range Cu/Al 60 °C or 75 °C	Catalog Number		
		Single-Pole 120/240 Vac Requires One 3/4-Inch (19.1 mm) Space 10 per Shelf Carton	Two-Pole 120/240 Vac Common Trip Requires Two 3/4-Inch (19.1 mm) Spaces 5 per Shelf Carton	Three-Pole 240 Vac Common Trip Requires Three 3/4-Inch (19.1 mm) Spaces 5 per Shelf Carton
10	(1) #14–8 ①	 <b>CH110</b>	 <b>CH210</b>	 <b>CH310</b>
15	(2) #14–10 ①② (1) #14–6 ③	<b>CH115</b> ⑥⑦	<b>CH215</b> ⑦	<b>CH315</b> ⑦
20		<b>CH120</b> ⑥⑦	<b>CH220</b> ⑦	<b>CH320</b> ⑦
25		<b>CH125</b> ⑦	<b>CH225</b> ⑦	<b>CH325</b> ⑦
30		<b>CH130</b> ⑦	<b>CH230</b> ⑦	<b>CH330</b> ⑦
35	#14–2 ① #14–6 ③	<b>CH135</b> ⑦	<b>CH235</b> ⑦	<b>CH335</b> ⑦
40	#10–1/0 ④	<b>CH140</b> ⑦	<b>CH240</b> ⑦	<b>CH340</b> ⑦
45	#14–2 #3/0	<b>CH145</b> ⑦	<b>CH245</b> ⑦	<b>CH345</b> ⑦
50		<b>CH150</b> ⑦	<b>CH250</b> ⑦	<b>CH350</b> ⑦
60		<b>CH160</b>	<b>CH260</b>	<b>CH360</b>
70		<b>CH170</b>	<b>CH270</b>	<b>CH370</b>
80		—	<b>CH280</b>	<b>CH3080</b>
90		—	<b>CH290</b>	<b>CH3090</b>
100		—	<b>CH2100</b>	<b>CH3100</b>
110		—	<b>CH2110</b>	—
125		—	<b>CH2125</b>	—

##### Type CH Plug-On Circuit Breakers



#### CHF Breakers with Mechanical Trip Flag

Ampere Rating	Wire Size Range Cu/Al 60 °C or 75 °C	Catalog Number	
		Single-Pole 120/240 Vac Requires One 3/4-Inch (19.1 mm) Space 10 per Shelf Carton	Two-Pole 120/240 Vac Common Trip Requires Two 3/4-Inch (19.1 mm) Spaces 5 per Shelf Carton
10	(1) #14–8 ①	 <b>CHF110</b>	 <b>CHF210</b>
15	(2) #14–10 ①②	<b>CHF115</b> ⑥⑦	<b>CHF215</b> ⑦
20		<b>CHF120</b> ⑥⑦	<b>CHF220</b> ⑦
25		<b>CHF125</b> ⑦	<b>CHF225</b> ⑦
30		<b>CHF130</b> ⑦	<b>CHF230</b> ⑦
35	#14–2 ①	<b>CHF135</b> ⑦	<b>CHF235</b> ⑦
40	#14–4 ④	<b>CHF140</b> ⑦	<b>CHF240</b> ⑦
45		<b>CHF145</b> ⑦	<b>CHF245</b> ⑦
50		<b>CHF150</b> ⑦	<b>CHF250</b> ⑦

##### Notes

- ① For single- and two-pole breakers.
- ② Solid and stranded wire can be used together.
- ③ For three-pole breakers.
- ④ Single-pole and two-pole 40–50 A.
- ⑥ Two-pole 150 A.
- ⑦ Switching duty rated.
- ⑦ HACR rated.

For factory-installed options, refer to **Page V1-T1-39**.

### Type CH AF/GF Single-Pole Circuit Breaker

Type CH AFCI Single-Pole Circuit Breaker



### Dual Purpose Arc Fault/Ground Fault 3/4-Inch (19.1 mm) Wide Circuit Breakers, Type CH, 120 Vac— 10 kAIC <sup>①②</sup>

Poles	Ampere Rating	Configuration	Catalog Number
Single-pole 10 kAIC	15	Combination AFCI GFCI	CHFAFGF115 <sup>③</sup>
	20	Combination AFCI GFCI	CHFAFGF120 <sup>③</sup>
Single-pole, plug-on neutral 10 kAIC	15	Combination AFCI GFCI	CHFAFGF115PN
	20	Combination AFCI GFCI	CHFAFGF120PN

### Plug-On Branch Feeder Type Arc Fault Circuit Breakers, Type CH 10 kAIC, 120 Vac and 120/240 Vac

Type CH AFCI Single-Pole Circuit Breaker



### Combination Type CH AFCI 3/4-Inch (19.1 mm) Wide Circuit Breakers

Poles	Ampere Rating	Catalog Number
<b>Standard Pigtail</b>		
Single-pole 10 kAIC	15	CHFCAF115
	20	CHFCAF120
Two-pole 10 kAIC	15	CH215CAF
	20	CH220CAF

Type CH AFCI Single-Pole Circuit Breaker



### Branch Type CH AFCI 3/4-Inch (19.1 mm) Wide FIRE-GUARD<sup>®</sup> Circuit Breakers

Poles	Ampere Rating	Configuration	Catalog Number
Single-pole 10 kAIC	15	AFCI	CH115AF <sup>③</sup>
	20	AFCI	CH120AF <sup>③</sup>
Two-pole 10 kAIC <sup>④⑤</sup>	15	AFCI common trip	CH215AF
	20	AFCI common trip	CH220AF

### Plug-On Combination Type Arc Fault Circuit Breakers and Ground Fault, Type CH 10 kAIC, 120 Vac and 120/240 Vac <sup>⑥</sup>

Type CH AFCI Single-Pole PON Combo Circuit Breaker



### Combination Type CH AFCI 3/4-Inch (19.1 mm) and CHGFCI Circuit Breakers

Poles	Ampere Rating	Configuration	Catalog Number
Single-pole 10 kAIC	15	AFCI plug-on neutral	CHFCAF115PN
	20	AFCI plug-on neutral	CHFCAF120PN
	15	GFCI plug-on neutral	CHFGFT115PN
	20		CHFGFT120PN
	25		CHFGFT125PN
	30		CHFGFT130PN

**Notes**

- ① Breaker qualifies as combination arc fault, per UL 1699.
- ② Breaker qualifies as personnel protection ground fault, (5 mA) per UL 943.
- ③ Clamshell packaging available with CS modification code on the end of catalog number.
- ④ Common trip refers to two-pole 240 V load application sourced by 120/240 Vac (see diagram on **Page V1-T1-40**).
- ⑤ Independent trip refers to two-pole multi-wire, home run or shared neutral circuits (see diagrams on **Page V1-T1-40**).
- ⑥ Requires plug-on neutral loadcenter.

# 1.1

## Loadcenters and Circuit Breakers

### Type CH Loadcenters and Circuit Breakers

1

#### Plug-On Ground Fault Circuit Breakers, Type CH 10 kAIC, 120 Vac and 120/240 Vac

##### Type CH Single-Pole



#### Type CH Ground Fault Circuit Breakers (5 Milliampere) 3/4-Inch (19.1 mm) per Pole 120 Vac or 120/240 Vac, 10 kAIC

Ampere Rating	Wire Size Range Cu/Al 60 °C or 75 °C ①	Catalog Number—1 per Shelf Carton	
		Single-Pole 120 Vac Requires One 3/4-Inch (19.1 mm) Space	Two-Pole 120/240 Vac Common Trip Requires Two 3/4-Inch (19.1 mm) Spaces
15	#14–6	CHFGFT115	CH215GFT
20	#14–6	CHFGFT120	CH220GFT
25	#14–6	CHFGFT125	CH225GFT
30	#14–6	CHFGFT130	CH230GFT
35	#14–6	—	CH235GFT
40	#14–6	—	CH240GFT
45	#14–6	—	CH245GFT
50	#14–6	—	CH250GFT
60	#14–6 ①	—	CH260GFT

##### Type CH Two-Pole



#### Type CH Ground Fault Equipment Protectors (30 Milliampere) 3/4-Inch (19.1 mm) per Pole 120 Vac or 120/240 Vac, 10 kAIC

Ampere Rating	Wire Size Range Cu/Al 60 °C or 75 °C ①	Catalog Number—1 per Shelf Carton	
		Single-Pole 120 Vac Requires One 3/4-Inch (19.1 mm) Space	Two-Pole 120/240 Vac Common Trip Requires Two 3/4-Inch (19.1 mm) Spaces
15	#14–6	CHFEP115	CH215EPD
20	#14–6	CHFEP120	CH220EPD
25	#14–6	CHFEP125	—
30	#14–6	CHFEP130	CH230EPD
40	#14–6	—	CH240EPD
50	#14–6	—	CH250EPD
60	#14–6 ①	—	CH260EPD

#### Type CH Switching Neutral Breakers—10 kAIC, 120 Vac and 120/240 Vac

Used to open the neutral along power line(s) for applications of gas pumps.

##### CH220SW



#### 3/4-Inch (19.1 mm) per Pole 120/240 or 240 Vac, 10 kAIC

Ampere Rating	Wire Size Range Cu/Al 60 °C or 75 °C	Catalog Number—1 per Shelf Carton	
		Two-Pole 120 Vac Common Trip Requires Two 3/4-Inch (19.1 mm) Spaces	Three-Pole 120/240 Vac Common Trip Requires Three 3/4-Inch (19.1 mm) Spaces
15	#14–8	CH215SW ②	CH315SW ③
20	#14–8	CH220SW ②	CH320SW ③
30	#14–8	CH230SW ②	CH330SW ③
40	#14–8	CH240SW ②	CH340SW ③
50	#14–8	CH250SW ②	CH350SW ③



##### Notes

- ① 60 A breaker listed for 75 °C Cu wire only.
- ② For circuit breakers with shunt trip, add ST suffix. Shunt trip requires one additional pole space.
- ③ Switching duty rated.

### Type CH-HID Circuit Breakers—10 kAIC, 120 Vac, 120/240 and 240 Vac

Suitable for use in circuits for fluorescent and high intensity discharge lighting. Also suitable for HACR applications.

#### 3/4-Inch (19.1 mm) per Pole 120 Vac, 120/240 and 240 Vac, 10 kAIC

Ampere Rating	Wire Size Range Cu/Al 60 °C or 75 °C	Single-Pole 120/240 Vac Requires One 3/4-Inch (19.1 mm) Space 10 per Shelf Carton Catalog Number	Two-Pole 240 Vac Common Trip Requires Two 3/4-Inch (19.1 mm) Spaces 5 per Shelf Carton Catalog Number	Three-Pole 240 Vac Common Trip Requires Three 3/4-Inch (19.1 mm) Spaces 5 per Shelf Carton Catalog Number
				
15	#14–8	CH115HID	CH215HID ①	CH315HID
20	#14–8	CH120HID	CH220HID	CH320HID
30	#14–8	CH130HID	CH230HID	CH330HID

### Type CHT Twin 10 kAIC, 120/240 Vac, Universal CTL and Non-CTL Plug-On Circuit Breakers

Suitable for CTL and Non-CTL CH loadcenters.

Type CH and CHT  
Circuit Breakers  
Mounted in Twin  
Breaker Panel

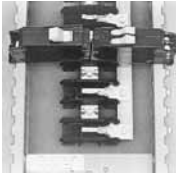

#### Twin (CTL) 3/4-Inch (19.1 mm) per Pole 120 Vac Class CTL 10 kAIC

Ampere Rating	Wire Size Range Cu/Al 60 °C or 75 °C	Single-Pole Requires One 3/4-Inch (19.1 mm) Space 10 per Shelf Carton Catalog Number
		 120/240 Vac 120/240 Vac
15–15	#14–8	CHT1515 ②③
15–20	#14–8	CHT1520 ②③
20–20	#14–8	CHT2020 ②③

#### Notes

- ① CH215HID is rated for 120/240 V.
- ② Switching duty rated.
- ③ HACR rated.



# 1.1

## Loadcenters and Circuit Breakers



### Type CH Loadcenters and Circuit Breakers

1

#### Type CHP Commercial Breakers—10 kAIC, 120 Vac, 120/240 Vac and 240 Vac

Note: CHP breakers feature on-off and trip positions for commercial applications.

#### 3/4-Inch (19.1 mm) per Pole 120, 120/240 or 240 Vac, 10 kAIC

Ampere Rating	Wire Size Range Cu/Al 60 °C or 75 °C	Single-Pole 120/240 Vac Requires One 3/4-Inch (19.1 mm) Space 10 per Shelf Carton Catalog Number	Two-Pole 120/240 Vac Common Trip Requires Two 3/4-Inch (19.1 mm) Spaces 5 per Shelf Carton Catalog Number	Three-Pole 240 Vac Common Trip Requires Three 3/4-Inch (19.1 mm) Spaces 5 per Shelf Carton Catalog Number
				
10	(1) #14–8 <sup>①</sup>	<b>CHP110</b>	<b>CHP210</b>	<b>CHP310</b>
15	(2) #14–10 <sup>①②</sup> (1) #14–6 <sup>③</sup>	<b>CHP115</b> <sup>⑥⑦</sup>	<b>CHP215</b> <sup>⑦</sup>	<b>CHP315</b> <sup>⑦</sup>
20		<b>CHP120</b> <sup>⑥⑦</sup>	<b>CHP220</b> <sup>⑦</sup>	<b>CHP320</b> <sup>⑦</sup>
25		<b>CHP125</b> <sup>⑦</sup>	<b>CHP225</b> <sup>⑦</sup>	<b>CHP325</b> <sup>⑦</sup>
30		<b>CHP130</b> <sup>⑦</sup>	<b>CHP230</b> <sup>⑦</sup>	<b>CHP330</b> <sup>⑦</sup>
35	#14–2 <sup>①</sup> #14–6 <sup>③</sup>	<b>CHP135</b> <sup>⑦</sup>	<b>CHP235</b> <sup>⑦</sup>	<b>CHP335</b> <sup>⑦</sup>
40	#10–1/0 <sup>④</sup>	<b>CHP140</b> <sup>⑦</sup>	<b>CHP240</b> <sup>⑦</sup>	<b>CHP340</b> <sup>⑦</sup>
45	#14–2 <sup>⑤</sup>	<b>CHP145</b> <sup>⑦</sup>	<b>CHP245</b> <sup>⑦</sup>	<b>CHP345</b> <sup>⑦</sup>
50		<b>CHP150</b> <sup>⑦</sup>	<b>CHP250</b> <sup>⑦</sup>	<b>CHP350</b> <sup>⑦</sup>
60		<b>CHP160</b> <sup>⑦</sup>	<b>CHP260</b> <sup>⑦</sup>	<b>CHP360</b> <sup>⑦</sup>
70		<b>CHP170</b>	<b>CHP270</b>	<b>CHP370</b>
80		—	<b>CHP280</b>	—
90		—	<b>CHP290</b>	—
100		—	<b>CHP2100</b>	<b>CHP3100</b>
110		—	<b>CHP2110</b>	—
125		—	<b>CHP2125</b>	—

#### Notes

- ① For single- and two-pole breakers.
- ② Solid and stranded wire can be used together.
- ③ For three-pole breakers.
- ④ Single-pole 60–70 A, two-pole 80–125 A, three-pole 40–100 A.
- ⑤ Single-pole 40–50 A, two-pole 40–70 A.
- ⑥ Switching duty rated.
- ⑦ HACR rated.

CHP breakers offer on-off and trip positions for commercial applications.

### Type CHP Neutral Switching Breakers—10 kAIC, 120 Vac and 120/240 Vac

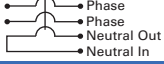

Used to open the neutral along power line(s) for applications of gas pumps.

#### 3/4-Inch (19.1 mm) per Pole 120 or 120/240 Vac, 10 kAIC

Ampere Rating	Wire Size Range Cu/Al 60 °C or 75 °C	Two-Pole 120 Vac Common Trip Requires Two 3/4-Inch (19.1 mm) Spaces 1 per Shelf Carton Catalog Number	Three-Pole 120/240 Vac Common Trip Requires Three 3/4-Inch (19.1 mm) Spaces 1 per Shelf Carton Catalog Number
			
15	#14–8	CHP215SW <sup>①</sup>	CHP315SW <sup>①</sup>
20	#14–8	CHP220SW <sup>①</sup>	CHP320SW <sup>①</sup>



### Type CH-M50 High Ambient Breaker

#### 3/4-Inch (19.1 mm) per Pole 120 or 120/240 Vac, 10 kAIC

Ampere Rating	Wire Size Range Cu/Al 60 °C or 75 °C	Single-Pole 120/240 Vac Requires One 3/4-Inch (19.1 mm) Space 10 per Shelf Carton Catalog Number	Two-Pole 120/240 Vac Common Trip Requires Two 3/4-Inch (19.1 mm) Spaces 5 per Shelf Carton Catalog Number
			
15	(1) #14–8	CH115M50	CH215M50
20	(2) #14–10	CH120M50	CH220M50
25		CH125M50	CH225M50
30		CH130M50	CH230M50
35		CH135M50	CH235M50
40		CH140M50	CH240M50
45		CH145M50	CH245M50
50		CH150M50	CH250M50
60		—	CH260M50
70		—	CH270M50

### Type CH-HM and CHP-HM High Magnetic Breakers

#### 3/4-Inch (19.1 mm) per Pole 120 or 120/240 Vac, 10 kAIC

Ampere Rating	Wire Size Range Cu/Al 60 °C or 75 °C	Single-Pole 120/240 Vac Requires One 3/4-Inch (19.1 mm) Space 10 per Shelf Carton Catalog Number	Two-Pole 120/240 Vac Common Trip Requires Two 3/4-Inch (19.1 mm) Spaces 5 per Shelf Carton Catalog Number
			
15	(1) #14–8	CH115HM	CH215HM
20	(2) #14–10	CH120HM	CH220HM
15	(1) #14–8	CHP115HM	CHP215HM
20	(2) #14–10	CHP120HM	CHP220HM

#### Note

<sup>①</sup> For circuit breakers with shunt trip, add ST suffix. Shunt trip requires one additional pole space, obtain pricing from [Page V1-T1-39](#).

# 1.1

## Loadcenters and Circuit Breakers

### Type CH Loadcenters and Circuit Breakers

1

#### Options and Accessories

CHHT



CHPL



CHPLGF



MCBPL



CHLO



CH125RB



CH9MB270



CHML



#### Field Installation Kits and Parts

Description	Ordering Quantity <sup>①</sup>	Catalog Number
<b>Handle Ties <sup>②</sup></b>		
Handle tie bar for physically joining the handles of two adjacent single-pole Type CH circuit breakers (molded plastic handle cover)	25	<b>CHHT</b>
<b>Handle Lockoffs <sup>③④</sup></b>		
Padlockable device for locking the handle of CH AFGF, CAF and GFT breakers into the ON or OFF position.		<b>CHFAFGFLOFF</b>
Padlockable device for locking the handle of single-, two- or three-pole Type CH circuit breakers (escutcheon mounted) <sup>⑤</sup>	1	<b>CHPL</b>
Padlockable device for locking the handle of a single-pole Type CHGFI circuit breaker (escutcheon mounted) <sup>⑤</sup>	1	<b>CHPLGF</b>
Padlockable bracket for locking the handle of two-, three- and four-pole Type CH circuit breakers	10	<b>CHPLOFF</b>
Padlockable device for locking the handle of main circuit breaker Types CC and CCH into the ON or OFF position.(screw mounted) <sup>⑥</sup>	1	<b>CCPL</b>
Padlockable device for locking the handle of main breaker Types BW and CSR into the ON or OFF position (escutcheon mounted) <sup>⑤</sup>	1	<b>MCBPL</b>
<b>Handle Lockdogs <sup>④⑦</sup></b>		
Device used to secure handle in ON or OFF position for single-pole Type CH circuit breakers (handle mounted) <sup>⑧</sup>	10	<b>CHLO</b>
<b>Hold-Down Kits <sup>⑨</sup></b>		
Hold-down retainer kit for single-, two-, three-pole Type CH circuit breakers. For 6–24 circuit 125 A single- and three-phase, 12–42 circuit single-phase 225 A and 24–42 circuit three-phase 225 A MLO Type CH loadcenters	1	<b>CH125RB</b>
Hold-down retainer kit for single-, two-, three-pole Type CH circuit breakers for 2–4 circuit MLO CH loadcenters.	1	<b>CH125RB24</b>
<b>Mounting Bases</b>		
Mounting base for two-pole Type CH circuit breaker—70 A maximum	1	<b>CH9MB270</b>
<b>Main Breaker Lug Kits</b>		
Types CC and CCH main breaker lug kit (2) 300 kcmil	1	<b>CCL300</b>
Type CSR main breaker lug kit (2) 300 kcmil	1	<b>MCBL300</b>
<b>Mechanical Interlock</b>		
Type CH for two-, three- and four-pole breakers	10	<b>CHML <sup>Ⓣ</sup></b>

#### Notes

- ① Must be purchased in multiples of ordering quantities indicated.
- ② Handle ties: typically used to join two similar independent single-pole breakers to form a two-pole noncommon trip breaker.
- ③ Handle lockoffs: devices that use a padlock to lock the circuit breaker's handle in the ON or OFF position.
- ④ Requires one additional pole space.
- ⑤ Escutcheon mounted: device mounted semipermanently to the face of the circuit breaker and secured by the loadcenter deadfront.
- ⑥ Screw mounted: device permanently mounted to the face of the circuit breaker by the use of a non-removable screw.
- ⑦ Handle lockdogs: devices that are used to secure a circuit breaker's handle in the ON or OFF position. Handle lockdogs are not padlockable devices.
- ⑧ Handle mounted: device mounted above or below handle using spring pressure.
- ⑨ Hold-down kits: devices used to secure the circuit breaker to the loadcenter for back-feed main application. See NEC Article 408.36(D).
- Ⓣ CHML not suitable to transfer emergency power.

### Shunt Trip Options

Description Type	Volts	Catalog Number Suffix Adder <sup>①</sup>
CSR	12 DC	<b>SR12</b>
CSR	24 DC	<b>SR24</b>
CSR	120 AC	<b>SR01</b>
CH	120 AC	<b>ST</b> <sup>②</sup>
CC	12 DC	<b>SR12</b>
CC	24 DC	<b>SR24</b>
CC	120 AC	<b>SR01</b>
CC	208 AC	<b>SR08</b>
CC	240 AC	<b>SR02</b>

### Handle Position Changeability Chart

Handle Lockoff and Lockdog Types	To Change Handle Position from ON to OFF or OFF to ON You Must...		
	Remove Padlock	Remove Device	Remove Loadcenter Deadfront
Lockoff escutcheon mounted	Remove	—	—
Lockoff screw mounted	Remove	—	—
Lockdog handle mounted	N/A	Remove	—

#### Notes

- ① Add suffix indicated to end of breaker catalog number.
- ② Requires one additional pole space.

# 1.1

## Loadcenters and Circuit Breakers

### Type CH Loadcenters and Circuit Breakers

1

#### Technical Data and Specifications

##### Ratings

Single- and two-pole CH breakers rated 15 and 20 A have low instantaneous magnetic trip levels. The 15 and 20 A breakers with “HM” suffix have high magnetic trip settings recommended for circuits with inherently high inrush currents. All Type CH breakers are marked for heating, air conditioning and refrigeration (HACR) equipment application. Single-pole 15–20 A breakers are also suitable for switching duty (SWD). Shunt trip coils operate on 120 Vac and require one additional pole space per breaker.

##### Wiring Diagrams

###### Typical Single-Pole

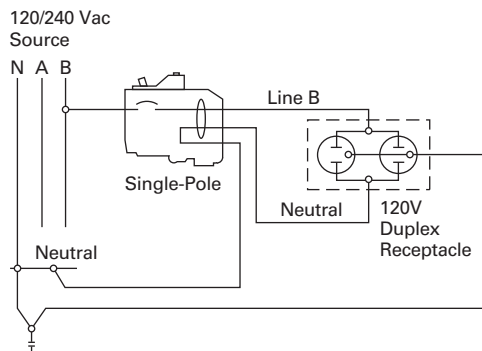

###### Two-Pole 240 V Load Application Sourced by 120/240 Vac

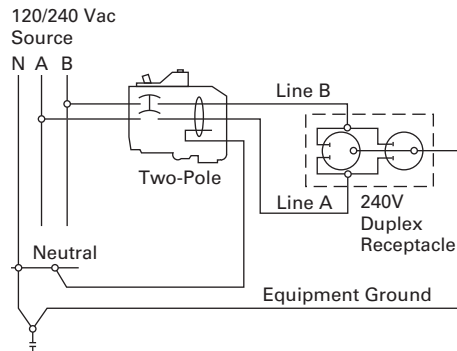

###### Single-Pole 120 V Load Application Sourced by 120/240 Vac

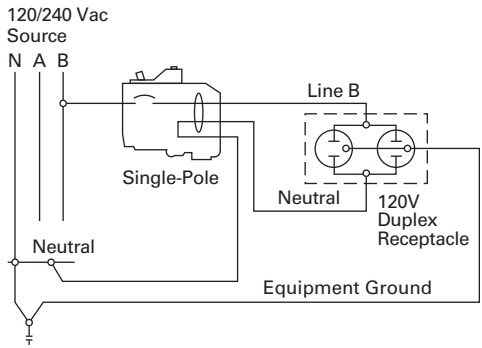

###### Two-Pole Shared Neutral with Duplex Receptacle Application

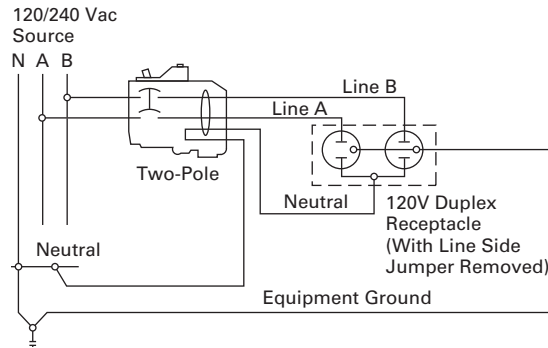

###### Two-Pole Shared Neutral with Multi-Duplex Receptacle Application

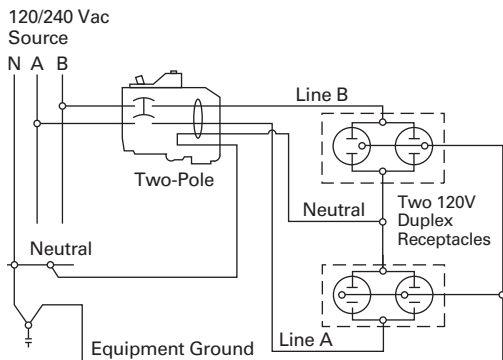

###### Single-Pole 120 V Duplex Receptacle Application

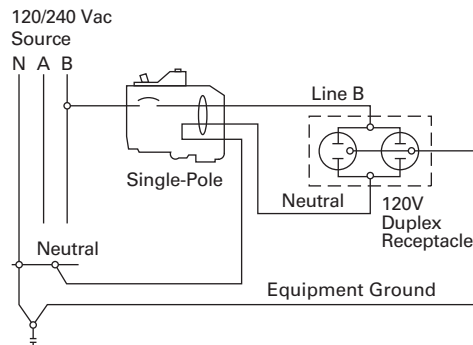

### Two-Pole 120 V Multi-Duplex Receptacle Application

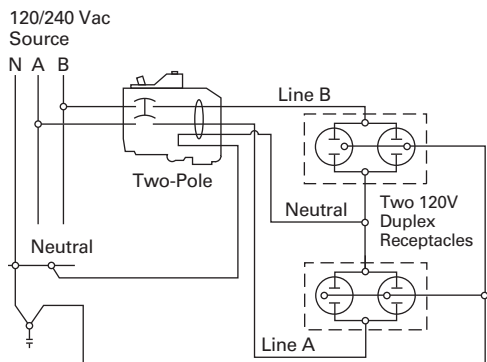

### Two-Pole 120 V Duplex Receptacle Application

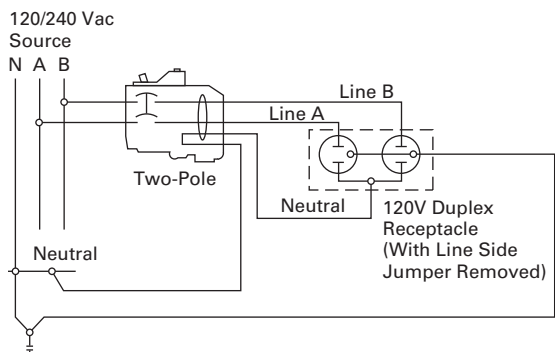

### Two-Pole 240 V Duplex Receptacle Application

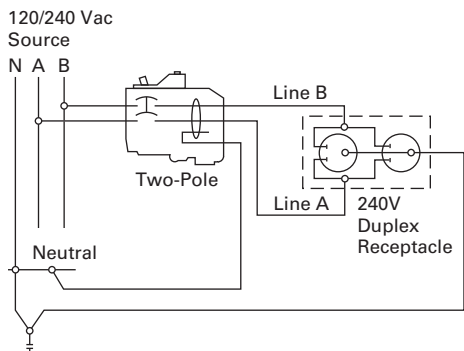

Type BR Loadcenters and Circuit Breakers



### Contents

<i>Description</i>	<i>Page</i>
Overview	
Standards and Certifications . . . . .	<b>V1-T1-43</b>
Catalog Number Selection . . . . .	<b>V1-T1-45</b>
Product Selection . . . . .	<b>V1-T1-46</b>
BR Specialty Products	
BR Quick Connect Neutral Loadcenters . . . . .	<b>V1-T1-57</b>
Spa Panels . . . . .	<b>V1-T1-58</b>
Riser Panel . . . . .	<b>V1-T1-59</b>
Type BR Renovation Loadcenter . . . . .	<b>V1-T1-60</b>
BR Loadcenter Options and Accessories . . . . .	<b>V1-T1-63</b>
BR Circuit Breakers . . . . .	<b>V1-T1-77</b>

### Overview

#### Product Description

Loadcenters are enclosures specifically designed to house the branch circuit breakers and wiring required to distribute power to individual circuits. They contain either a main breaker when used at the service entrance point or a main lug when used as a sub-panel to add circuits to existing service. The main breaker protects the main entire panel and can be used as a service disconnect. The branch breakers protect the wires leading to individual electrical loads such as fixtures and outlets.

#### Features, Benefits and Functions

##### Loadcenter Construction

Eaton's Type BR loadcenters have standard tin-plated aluminum bus with a limited availability of copper bus. The sum of the handle ratings connected to any stab is limited to 150 A maximum on the 100 and 125 A loadcenters, and 200 A on loadcenters with 150 A or higher main bus. NEMA Type 1 boxes or enclosures are manufactured from galvanized steel. Raintight boxes are manufactured from galvanized steel, then finished using an electrostatic powder coat, baked urethane paint process.

##### Neutrals

Eaton Type CH loadcenters feature two types of neutrals:

##### Insulated/Bondable Split Neutral

Panels are supplied with split insulated neutrals with an insulated cross strap. For service entrance applications, the neutral must be bonded by using the bonding strap supplied with the panel. For non-service entrance (sub-panel) applications, the panel may be installed with the bonding strap not connected to the neutral. Separate ground bars must be used on non-service entrance panels.

##### Insulated/Bondable Single Neutral

Panels are supplied with a single insulated neutral. For service entrance applications, all that is required to bond the neutral is to loosen the bonding screw and the neutral screw directly beside it, insert the bonding strap into the neutral bar, and re-tighten both connections. The single neutral can be moved by the contractor to the other side of the panel, if desired. When used as a service entrance panel, unused neutral connections may be used for the termination of equipment grounds. For non-service entrance (sub-panel) applications, the panel may be installed with the bonding strap not connected to the neutral. Separate ground bars must be used on non-service entrance panels.

**Grounds**

In service entrance applications where the neutral is bonded, unused neutral holes may be used for terminating ground conductors. In sub-feed panels, the neutral must be isolated (non-bonded), and ground wires must be terminated on a separate ground bar.

The insulated/bondable single/split neutral panels have sufficient terminations for both ground and neutral conductors. The insulated/bondable single split neutral panels are supplied with a separate factory-installed ground bar if the catalog number contains a "G." If not, a separate ground bar should be installed. Insulated/Bondable Single Neutral panels are supplied without a ground bar (unless otherwise noted), and ground bar kits if needed must be purchased separately.

**Neutral and Ground Terminals**

The standard terminals on grounds and neutrals are rated to accept (3) #14–#10 Cu/Al or (1) #14–4, provided the cables terminated are of the same material. For larger cables, add-on neutral lugs may be ordered from the accessories on **Page V1-T1-68**.

**Note:** NEC allows only one current-carrying conductor per hole on neutrals unless otherwise noted.

**Bottom Fed Loadcenters**

For single-phase 225 A and below loadcenters that are bottom fed, a standard panel can be rotated 180 degrees to allow straight-in wiring of power cables to the main terminals. Because the main circuit breaker handle operates horizontally, the orientation of the main circuit breaker handle is consistent with the requirements of NEC 2008 Article 240.81.

**Gutter Splicing**

Loadcenters are not UL listed as wiring troughs. Therefore, gutter splicing of riser cables to tap off to the main device is not permitted. Refer to NEC 2008 Article 312.8.

**Fire Rating**

Due to the numerous openings in both loadcenter boxes and trims, they should not be mounted in firewalls. There is no approved method for sealing the enclosures for this application.

**Date Code**

The date of manufacture of each loadcenter is printed on the outside of the carton as well as inside the loadcenter. On the carton, the date code is printed on the end carton label. In the loadcenter, the date code is located on the small white label located on the right side wall (with the main device on top).

The date code is in the following format: F # # # &. The "F" is the numeric code for the Lincoln, IL plant, and the three numbers are the year and week of manufacturing, e.g., 023. The "!" sign at the end signifies the decade of the 2010. Therefore, the date code F023! would indicate that the product was manufactured in the 23rd week of 2010. The 1980s are represented by the "+" sign and the 1990s are represented by a "=" at the end of the code.

**Surge Protectors**

Complete home surge protection is available in multiple options, including a factory-installed option that provides the highest level of surge protection in a residential design. See Tab 3 for more details.

**Circuit Breaker Case Interrupting Capacity**

- 10 kAIC
- 22 kAIC
- 25 kAIC

**Warranty Information**

- 10-year limited loadcenter warranty
- 10-year limited branch breaker warranty

**Standards and Certifications****UL Listings**

All Eaton Type BR loadcenters are listed under UL File E52977 except the 2–8 circuit loadcenters, up through and including 125 A, which are listed under UL File E8741.





# 1.2

## Loadcenters and Circuit Breakers

### Type BR Loadcenters and Circuit Breakers

1

#### Type BR Loadcenter

Extra 1.5 inch Knockout (38.1 mm)

- Larger knockout provides easier installation and time savings

Top or Bottom Feed

- Straight-in wiring saves labor and material
- One panel for either top or bottom applications

2/0 Lug

- Easily removable and can be installed in any location on the neutral bar

Type BR AFCI Breakers

- Compact design for easier wiring and improved wireway access
- Optional LED indicates one of six trip codes for circuit diagnostics
- Provides a clean gutter space

Standard Tin-Plated Aluminum Bus

- Excellent conductivity and corrosion resistance
- Copper bus options available for select catalog numbers

Drywall Marking on Enclosure

- Indicates proper mounting depth for flush applications

"Tangential" Center Knockout

- Easier installation for conduit applications

Commercial Grade Main Breaker

- 25 kAIC series rated main breaker for superior protection

Neutral Bus (Strap)

- Is easily removable for sub-panel applications

Bonding Z-Strap

- Provides easy field conversion for service entrance applications

Twin Neutral Bars

- Minimum 150% neutral capacity

Steel Backpan

- Provides solid and reliable breaker mounting—single piece design for stability and durability

Single Keyhole Mounting

- One keyhole at the top and bottom provides easier mounting and leveling

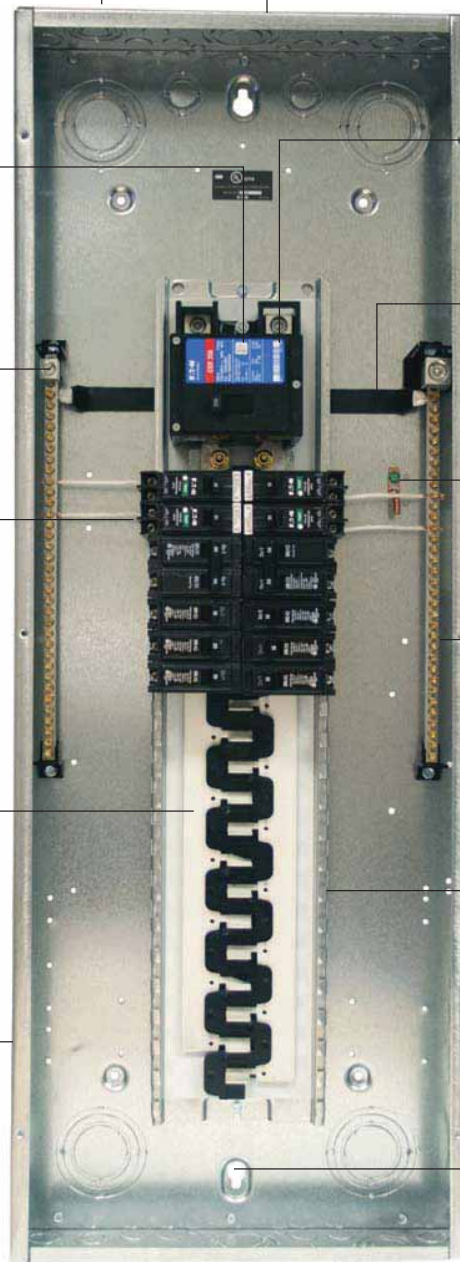

#### Warranty

10-year warranty on all Type BR loadcenters and circuit breakers.

### Catalog Number Selection

#### Single- and Three-Phase Through 600 A

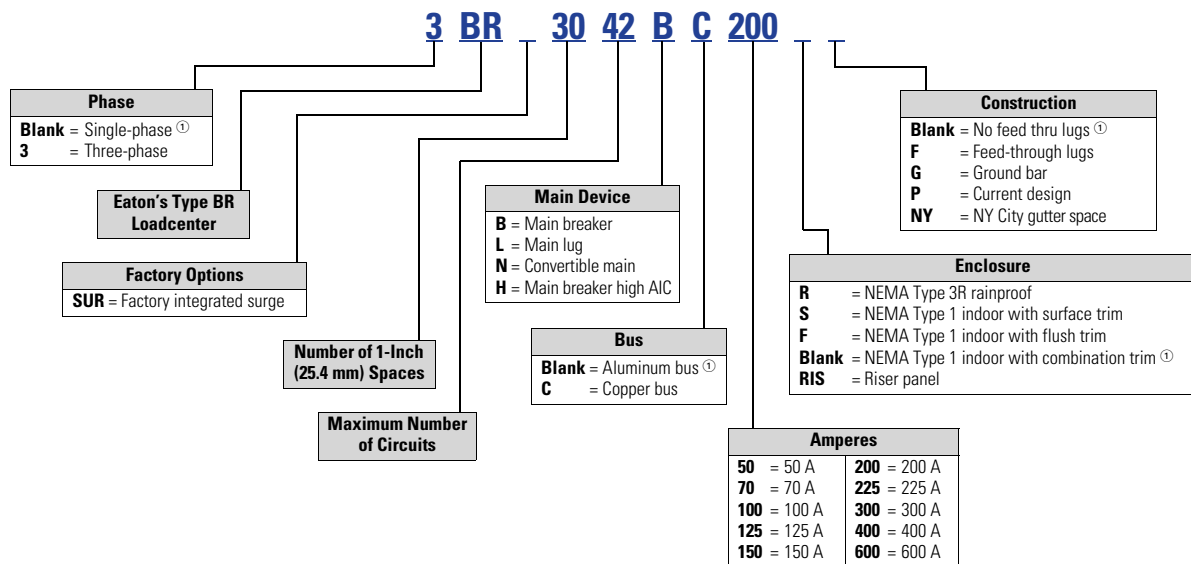

**Note**

① No character space used.

#### 1

#### Product Selection

#### Single-Phase—Main Circuit Breaker Loadcenters—10/25 kAIC

BR4040B200



#### Single-Phase Three-Wire—120/240 Vac—Insulated/Bondable Split Neutral

Main Breaker Type	Main Ampere Rating	Maximum Number 1-Inch (25.4 mm)		Enclosure Type	Box Size	Wire Size Range Cu/Al 60 °C or 75 °C for Main Breaker	Loadcenter Catalog Number with Combination <sup>①</sup> or NEMA Type 3R Cover			
		Spaces	Circuits							
BR 10 kAIC	100	8	16	Indoor	B1	#4–1/0 <sup>②</sup>	BR816B100			
		10	20	Indoor	A1		BR1020B100S11			
		10	20	Indoor	A1		BR1020B100F11			
		10	20	Outdoor	B2R		BR1020B100RF <sup>③④</sup>			
		12	12	Indoor	B2		BR1212B100			
		12	20	Indoor	B2		BR1220B100			
		12	24	Outdoor	B2R		BR1224B100R <sup>④</sup>			
		16	16	Indoor	C1		BR1616B100			
		16	20	Indoor	C1		BR1620B100			
		16	24	Outdoor	C1R		BR1624B100R <sup>④</sup>			
		20	24	Outdoor	C3R		BR2024B100R <sup>④</sup>			
		20	20	Indoor	C2		BR2020B100			
	16	24	Indoor	C1	BR1624B100					
	30	30	Indoor	D1	BR3030B100					
	125	125	16	24	Indoor	C1	#4–2/0	BR1624B125		
			20	24	Indoor	C1		BR2024B125		
			20	24	Outdoor	C3R		BR2024B125R <sup>④</sup>		
			30	30	Indoor	D1		BR3030B125		
	BRH <sup>⑤</sup> 22 kAIC	100	20	24	Indoor	C2	#4–1/0	BR2024H100 <sup>⑤</sup>		
CSR <sup>⑥</sup> 25 kAIC	150	8	16	Outdoor	C3R	#2–300 kcmil	BR816B150RF <sup>③④</sup>			
		16	30	Indoor	C4		BR1630B150			
		20	30	Indoor	C4		BR2030B150			
		20	30	Outdoor	D1R		BR2030B150R <sup>④</sup>			
		20	40	Indoor	D1		BR2040B150			
		20	40	Outdoor	D1R		BR2040B150R <sup>④</sup>			
		24	30	Indoor	G1		BR2430B150			
		30	30	Outdoor	G1R		BR3030B150R <sup>④</sup>			
		30	30	Indoor	G1		BR3030B150			
		30	40	Indoor	G1		BR3040B150			
		200	200	4	8		Outdoor	8R	#2–300 kcmil	BR48B200RF <sup>③⑦⑧</sup>
				8	16		Outdoor	C3R		BR816B200RF <sup>③④</sup>
	16			32	Indoor	C4	BR1632B200			
	20			40	Outdoor	D1R	BR2040B200R <sup>④</sup>			
	20			40	Indoor	D1	BR2040B200			
	24			40	Indoor	G1	BR2440B200			
	30			40	Outdoor	G1R	BR3040B200R <sup>④</sup>			
	30			40	Indoor	G1	BR3040B200 <sup>⑨</sup>			
	225	225	40	40	Outdoor	L1R	#1–250 kcmil	BR4040B200R <sup>④</sup>		
40			40	Indoor	L1	BR4040B200				
40			50	Indoor	L1	BR4050B200				
60			120	Indoor	L3	BR60120B200				
60			120	Outdoor	L3R	BR60120B200R				
42			42	Indoor	L2	BR4242B225				
42	42	Outdoor	L2R	BR4242B225R <sup>④</sup>						

#### Notes

- ① Combination style covers may be used in surface or flush applications.
- ② Wire range size for BR1020B100SP is #6–#1 Cu/Al.
- ③ Includes through-feed lugs for both phase and neutral conductors.
- ④ Rainproof panels are furnished with hub closure plates. For rainproof hubs, refer to **Page V1-T1-68**.
- ⑤ 22 kAIC series combination rating is obtained when Types BD, BR, BQ, BQC and GFTCB 10 kAIC branch breakers are used in series with Type BRH main breaker.
- ⑥ 25 kAIC series combination rating is obtained when Types BD, BR, BQ, BQC and GFTCB 10 kAIC branch circuit breakers are used in series with Type CSR main breaker.
- ⑦ Supplied with adapter plate to use DS Group1 hubs on **Page V1-T1-68**. If 2.50-inch (63.5 mm) hub is needed, remove adapter and use ARP00007CH25 hub.
- ⑧ Neutral is bonded—suitable for service entrance only—cannot be converted for sub-feed application.
- ⑨ Add G to the end of the catalog number for factory-installed GBK2120 ground bar.

All main circuit breaker loadcenters are listed for use as service entrance equipment and are shipped with neutral bonding strap preattached. The maximum rating of the panel is the main circuit breaker rating when used as service entrance equipment. Ground bar kits priced separately. See **Page V1-T1-68**.

### Main Circuit Breaker Loadcenters—10/22 kAIC

B4242DFN



#### Single-Phase Three-Wire—120/240 Vac—Insulated/Bondable Split Neutral

Main Breaker Type	Main Ampere Rating	Maximum Number 1-Inch (25.4 mm)		Enclosure Type	Box Size	Wire Size Range Cu/Al 60 °C or 75 °C for Main Breaker	Commercial Loadcenter Catalog Number <sup>①②③</sup>	
		Spaces	Circuits				With Flush or NEMA Type 3R Cover	With Surface Cover
DK <sup>④</sup>	300	42	42	Indoor	24	(2) #3/0–250 kcmil	BR4242B300F	BR4242B300S
	400	42	42	Indoor	24	(2) #3/0–250 kcmil	BR4242B400F	BR4242B400S
		42	42	Outdoor	47	(2) #3/0–250 kcmil	BR4242B400R <sup>⑤</sup>	—
HLD <sup>⑥</sup>	600	42	42	Indoor	24	(2) #3/0–500 kcmil	—	BR4242B600S

#### Notes

- ① Ground bar kits priced separately. See **Page V1-T1-68**.
- ② The maximum rating of the panel is the main circuit breaker rating when used as service entrance equipment.
- ③ Door lock and key included with loadcenter.
- ④ Type DK main circuit breaker is rated 65 kAIC at 240 Vac and allows a 22 kAIC series rating on the panel when Types BR, BD and BJ branch circuit breakers are used.
- ⑤ Rainproof panels are furnished with hub closure plates. For rainproof hubs, refer to **Page V1-T1-68**.
- ⑥ Type HLD main circuit breaker is rated 65 kAIC at 240 Vac. Type HLD circuit breaker **is not** series rated with Types BR, BD and BJ branch circuit breakers.

Box sizes **Pages V1-T1-73 through V1-T1-76**.

Please contact the Lincoln Flex Center for any configurations not listed.

#### Single-Phase—Main Lug Loadcenters

#### Single-Phase Three-Wire—120/240 Vac—Insulated/Bondable Split Neutral

Main Ampere Rating	Maximum Number 1-Inch (25.4 mm)		Enclosure Type	Trim Type	Box Size	Wire Size Range Cu/Al 60 °C or 75 °C for Main Lugs	Loadcenter Catalog Number		
	Spaces	Circuits							
70	Surface	Outdoor	Indoor	Surface (no door)	5	#8-#2	BR24L70SP <sup>①②</sup>		
			Indoor	Surface (no door)	5		BR24L70SGP <sup>②③</sup>		
	Outdoor	—	5R	BR24L70RP <sup>①②④</sup>					
	Indoor	Flush (no door)	5	BR24L70FP <sup>①②</sup>					
	Indoor	Flush (no door)	5	BR24L70FGP <sup>②⑤</sup>					
125	Flush	Outdoor	Indoor	Surface (no door)	6	#14-1/0	BR24L125SP <sup>①②</sup>		
			Outdoor	—	6R		BR24L125RP <sup>①②④</sup>		
	Surface (No Door)	Outdoor	Indoor	—	6R	#14-1/0	BR24L125RSEP <sup>②⑦⑧</sup>		
			Indoor	—	6R		BR24L125RSEP <sup>②⑥⑦</sup>		
	Flush (No Door)	Outdoor	Indoor	Flush (no door)	6	#14-1/0	BR24L125FP <sup>①②</sup>		
			Indoor	Surface (no door)	7		BR48L125SP <sup>①⑨</sup>		
			Indoor	Surface (no door)	7		BR48L125SGP <sup>③⑨</sup>		
			Outdoor	—	7R		BR48L125RP <sup>①④⑨</sup>		
			Indoor	Flush (no door)	7		BR48L125FP <sup>①⑨</sup>		
			Indoor	Flush (with door)	7		BR48L125FDP <sup>①⑨</sup>		
			Indoor	Flush (no door)	7		BR48L125FGP <sup>③⑨</sup>		
			Indoor	Surface (no door)	7		#14-#1	BR612L125SP <sup>①⑩</sup>	
	Indoor	Surface (no door)	7	BR612L125SGP <sup>⑩⑪</sup>					
	Indoor	Surface (with door)	7	BR612L125SDP <sup>①⑩</sup>					
	Indoor	Surface (with door)	7	BR612L125SDGP <sup>⑩⑪</sup>					
	Outdoor	Outdoor	Indoor	—	7R	#14-#1	BR612L125RP <sup>①④⑩</sup>		
			Indoor	Flush (no door)	7		BR612L125FP <sup>①⑩</sup>		
			Indoor	Flush (no door)	7		BR612L125FGP <sup>⑤⑩⑪</sup>		
			Indoor	Flush (with door)	7		BR612L125FDP <sup>⑩</sup>		
			Indoor	Flush (with door)	7		BR612L125FDGP <sup>⑤⑩⑪</sup>		
Indoor			Surface (no door)	7	#14-#1		BR816L125SP <sup>①⑩</sup>		
Indoor			Surface (no door)	7			BR816L125SGP <sup>⑩⑫</sup>		
Indoor			Surface (with door)	7			BR816L125SDP <sup>①⑩</sup>		
Indoor			Surface (with door)	7			BR816L125SDGP <sup>⑩⑫</sup>		
Outdoor			Outdoor	Outdoor	—		7R	#14-#1	BR816L125RP <sup>①④⑩</sup>
				Indoor	Flush (no door)		7		BR816L125FP <sup>①⑩</sup>
				Indoor	Flush (no door)		7		BR816L125FGP <sup>⑤⑩⑫</sup>
	Indoor	Flush (with door)		7	BR816L125FDP <sup>①⑩</sup>				
	Indoor	Flush (with door)		7	BR816L125FDGP <sup>⑤⑩⑪</sup>				



#### Notes

- ① Ground bar kits priced separately. See **Page V1-T1-68**.
  - For 2/4 circuit loadcenters, use GBK5 or GBK520 ground bar.
  - For 4/8, 6/12 and 8/16 circuit loadcenters, use GBK10 ground bar.
  - Ground bars mount to the left side wall of the enclosure for the 4/8, 6/12 and 8/16 circuit loadcenters.
- ② Suitable for use as service equipment when not more than two service disconnecting mains are provided or when not used as a lighting and appliance panelboard.
- ③ Ground bar GBK5 is installed.
- ④ Rainproof panels are furnished with hub closure plates. For rainproof hubs, refer to **Page V1-T1-68**.
- ⑤ CSA and UL approved.
- ⑥ Neutral/ground holes (6) #14-6 and (3) #14-2/0 AWG Cu/Al.
- ⑦ For use as service entrance applications only.
- ⑧ Neutral/ground holes (6) #14-6 and (3) #14-1/0 AWG Cu/Al.
- ⑨ Suitable for use as service equipment when not more than two service disconnecting mains are provided or when not more than six service disconnecting mains are provided and when not used as a lighting and appliance panelboard.
- ⑩ Suitable for use as service equipment when a main breaker is used or when not more than six service disconnecting mains are provided and when not used as a lighting and appliance panelboard.
- ⑪ Ground bar GBK10 is installed.
- ⑫ Ground bar GBK14 is installed.

Box sizes **Pages V1-T1-73 through V1-T1-76**.

### Single-Phase—Main Lug Loadcenters

#### Single-Phase Three-Wire—120/240 Vac—Insulated/Bondable Split Neutral, continued

Main Ampere Rating	Maximum Number 1-Inch (25.4 mm)		Enclosure Type	Box Size	Wire Size Range Cu/Al 60 °C or 75 °C for Main Lugs	Loadcenter Catalog Number with Combination or NEMA Type 3R Cover ①	
	Spaces	Circuits					
BR1224L125 	125	12	12	Indoor	B1	#6–2/0 BR1212L125 ②③④⑤	
		12	24	Indoor	B1	BR1224L125 ②④⑤	
		12	24	Indoor	B1	BR1224L125G ②④⑤	
		12	24	Indoor	B1	BR1224L125DG ②④⑤⑥	
		12	24	Outdoor	B1R	BR1224L125R ②⑤⑦	
		16	16	Indoor	B2	BR1616L125 ②④⑤	
		16	24	Indoor	B2	BR1624L125 ②④	
		16	24	Indoor	B2	BR1624L125G ②④	
		16	24	Outdoor	B2R	BR1624L125R ②⑦	
		20	20	Indoor	C1	BR2020L125 ②④⑤	
		20	24	Indoor	C1	BR2024L125 ②④	
		20	24	Indoor	C1	BR2024L125G ②④⑧	
		20	24	Outdoor	C1R	BR2024L125R ②⑦	
		24	24	Indoor	C2	BR2424L125 ②④	
		24	24	Indoor	C2	BR2424L125G ②④⑧	
		30	42	Indoor	D1	BR3042L125 ②④	
		150	16	30	Indoor	C2	#1–300 kcmil BR1630L150 ④⑨
			20	30	Indoor	C2	BR2030L150 ④⑨
		BR1224L200 	200	8	16	Outdoor	B2R
12	24			Indoor	B2	BR1224L200 ④⑤⑨	
12	24			Outdoor	B2R	BR1224L200R ⑤⑦⑨	
20	40			Indoor	C2	BR2040L200 ④⑨	
20	40			Indoor	C2	BR2040L200G ④⑧⑨	
20	40			Outdoor	C3R	BR2040L200R ⑦⑨	
24	40			Indoor	C4	BR2440L200 ④⑨	
30	40			Indoor	D1	BR3040L200 ④⑨	
30	40			Indoor	D1	BR3040L200G ④⑧⑨	
30	40			Outdoor	D1R	BR3040L200R ⑦⑨	
40	40			Indoor	G1	BR4040L200 ④⑨	
40	40			Indoor	G1	BR4040L200G ④⑨	
40	40			Outdoor	G1R	BR4040L200R ⑦⑨	
60	120			Indoor	L3	BR60120L200 ⑩	
225	42			42	Indoor	L1	#1–300 kcmil BR4242L225 ④
	42	42	Outdoor	L1R	BR4242L225R ⑦		

#### Notes

- ① Ground bar kits priced separately unless otherwise noted. See **Page V1-T1-68**.
- ② Has notch for BREQS125 hold-down kit.
- ③ Single, movable neutral is provided.
- ④ Combination cover style.
- ⑤ Suitable for use as service equipment when not more than six main disconnecting means are provided and when not used as a lighting and appliance panelboard.
- ⑥ Ground bars GBK5 and GBK520 installed.
- ⑦ Rainproof panels are furnished with hub closure plates. For rainproof hubs, refer to **Page V1-T1-68**.
- ⑧ Ground bar GBK1220 installed.
- ⑨ Has notch for BRHDK125 hold-down kit.
- ⑩ Includes through-feed lugs for both phase and neutral conductors.
- ⑪ Includes main lugs. Loadcenters can convert to main breaker using kit.

# 1.2

## Loadcenters and Circuit Breakers

### Type BR Loadcenters and Circuit Breakers

1

#### Single-Phase—Main Lug Loadcenters—400 and 600 A

4242DFN



#### Single-Phase Three-Wire—120/240 Vac—Insulated/Bondable Split Neutral

Main Ampere Rating	Maximum Number 1-Inch (25.4 mm)		Enclosure Type	Box Size	Wire Size Range Cu/Al 60 °C or 75 °C for Main Lugs	Commercial Loadcenter Catalog Number <sup>①②③</sup>	
	Spaces	Circuits				With Flush or NEMA Type 3R Cover	With Surface Cover
400	12	24	Outdoor	42	(2) #3/0–400 kcmil	BR1224L400R <sup>④⑤</sup>	—
	42	42	Indoor	22		BR4242L400F	BR4242L400S
	42	42	Outdoor	46		BR4242L400R <sup>④</sup>	—
600	42	42	Indoor	22	(2) #2–500 kcmil	—	BR4242L600S

#### Notes

- ① Ground bar kits priced separately unless otherwise noted. See **Page V1-T1-68**.
- ② Has notch for BRHDK125 hold-down kit.
- ③ Ground bar GBK8 installed.
- ④ Rainproof panels are furnished with hub closure plates. For rainproof hubs, refer to **Page V1-T1-68**.
- ⑤ Suitable for use as service equipment when not more than six main disconnecting means are provided and when not used as a lighting and appliance panelboard.

**Convertible Loadcenters MCB or MLO—Base Units and Main Devices 10/22/25 kAIC, Complete Assembly Consists of: Loadcenter and Either Main Breaker Kit or Main Lug Kit**

**Note:** Interrupting rating depends on main circuit breaker selected.

**BR3040N200**



**Base Units—Single-Phase Three-Wire—120/240 Vac—Insulated/Bondable Split Neutral (Unless Otherwise Noted)**

Main Ampere Rating <sup>①</sup>	Maximum Number 1-Inch (25.4 mm)		Enclosure Type	Box Size	Wire Size Range Cu/Al 60 °C or 75 °C for Main	Loadcenter Catalog Number With Combination or NEMA Type 3R Cover <sup>②③</sup>
	Spaces	Circuits				
125 <sup>④</sup>	12	24	Indoor	B2	See main breaker and main lug kit tables <b>Page V1-T1-54.</b>	<b>BR1224N125</b> <sup>⑤⑥</sup>
	12	24	Outdoor	B2R		<b>BR1224N125R</b> <sup>⑤⑥⑦</sup>
	16	24	Indoor	C1		<b>BR1624N125</b> <sup>⑤</sup>
	16	24	Outdoor	C1R		<b>BR1624N125R</b> <sup>⑤⑦</sup>
	20	24	Indoor	C2		<b>BR2024N125</b> <sup>⑤</sup>
	20	24	Outdoor	C3R		<b>BR2024N125R</b> <sup>⑤⑦</sup>
200 <sup>⑧</sup>	8	16	Outdoor	C3R	<b>BR816N200RF</b> <sup>⑦⑨⑩⑪</sup>	
	12	24	Indoor	C4	<b>BR1224N200</b> <sup>⑩</sup>	
	12	24	Outdoor	C3R	<b>BR1224N200R</b> <sup>⑦⑩</sup>	
	16	32	Indoor	C4	<b>BR1632N200</b> <sup>⑩</sup>	
	20	40	Indoor	D1	<b>BR2040N200</b> <sup>⑩</sup>	
	20	40	Indoor	D1	<b>BR2040N200G</b> <sup>⑫</sup>	
	20	40	Outdoor	D1R	<b>BR2040N200R</b> <sup>⑦⑩</sup>	
	20	40	Outdoor	D1R	<b>BR2040N200RG</b> <sup>⑫</sup>	
	24	40	Indoor	G1	<b>BR2440N200</b> <sup>⑦⑩</sup>	
	30	40	Indoor	G1	<b>BR3040N200</b> <sup>⑩</sup>	
	30	40	Indoor	G1	<b>BR3040N200G</b> <sup>⑫</sup>	
	30	40	Outdoor	G1R	<b>BR3040N200R</b> <sup>⑦⑩</sup>	
	30	40	Outdoor	G1R	<b>BR3040N200RG</b> <sup>⑫</sup>	
	40	40	Indoor	L1	<b>BR4040N200</b> <sup>⑩</sup>	
	40	40	Indoor	L1	<b>BR4040N200G</b> <sup>⑫</sup>	
	40	40	Outdoor	L1R	<b>BR4040N200R</b> <sup>⑦⑩</sup>	
	40	40	Outdoor	L1R	<b>BR4040N200RG</b> <sup>⑫</sup>	
	40	50	Indoor	L1	<b>BR4050N200</b>	
40	50	Outdoor	L1R	<b>BR4050N200R</b>		

**Notes**

- ① The maximum rating of the loadcenter is the main circuit breaker rating when used as service entrance equipment.
- ② 100, 125 and 200 A convertible base unit catalog numbers include interior, box and cover only. Main devices and accessories must be ordered separately for field installation. All convertible base units are listed as suitable for use as service entrance equipment when used per Article 408 of the NEC.
- ③ Ground bar kits priced separately except as noted, refer to **Page V1-T1-68.**
- ④ For main breaker, use Type BR. For main lug use Type BRSF.
- ⑤ BREQS125 hold-down screw comes with loadcenter for back-fed Types BR and BRH main circuit breakers.
- ⑥ Convertible to maximum of 100 A main circuit breaker and 125 A main lug.
- ⑦ Rainproof loadcenters are furnished with hub closure plates. For rainproof hubs, refer to **Page V1-T1-68.**
- ⑧ For main breaker, use Type BW or CSR. For main lug, use Type BRL.
- ⑨ Includes through-feed lugs for both phase and neutral conductors.
- ⑩ No hold-down provisions for back-fed Types BR and BRH main circuit breakers.
- ⑪ Insulated/bondable single neutral.
- ⑫ Includes GBK2120 ground bar.



# 1.2

## Loadcenters and Circuit Breakers

### Type BR Loadcenters and Circuit Breakers

1

#### Convertible Loadcenters MCB or MLO—Base Units and Main Devices 10/22/25 kAIC, Complete Assembly Consists of: Loadcenter and Either Main Breaker Kit or Main Lug Kit

**Note:** Interrupting rating depends on main circuit breaker selected.

##### BW2200



#### Main Devices—Two- and Three-Pole Main Circuit Breakers—120/240 Vac or 208Y/120 Vac or 240 Vac

Ampere Rating	Wire Size Range Cu/Al 60 °C or 75 °C for Main Breaker	10 kAIC Catalog Number	22/25 kAIC Catalog Number ①
<b>Two-Pole</b>			
100	#4–1/0	BR2100	BRH2100
110	#4–1/0	BR2110	BRH2110
125	#4–2/0	BR2125	BRH2125
125	#2–300 kcmil	BW2125	CSR2125N
150	#2–300 kcmil	BW2150	CSR2150N
175	#2–300 kcmil	BW2175	CSR2175N
200	#2–300 kcmil	BW2200	CSR2200N
<b>Three-Pole</b>			
100	#1	BR3100	BRH3100

##### BRL200



#### Main Devices—Two- and Three-Pole Main Lug Kits—120/240 Vac or 208Y/120 Vac or 240 Vac

Ampere Rating	Wire Size Range Cu/Al 60 °C or 75 °C for Main Lugs	Catalog Number
<b>Two-Pole</b>		
125	#6–2/0	BRSF125
150	#1–300 kcmil	BRL200
175	#1–300 kcmil	BRL200
200	#1–300 kcmil	BRL200
<b>Three-Pole</b>		
150	#6–3/0	3BRSF150

#### Main Circuit Breaker with Accessory

Example: BW22005R01 (Put description with catalog number on order. See **Page V1-T1-87.**)

#### Main Circuit Breaker Loadcenters—Copper Bus 10/22/25 kAIC

##### BR3030BC100



#### Main Circuit Breaker Loadcenters—With Copper Bus—Single-Phase Three-Wire—120/240 Vac—Insulated/Bondable Split Neutral

Main Breaker Type	Main Ampere Rating	Maximum Number 1-Inch (25.4 mm)		Enclosure Type	Box Size	Wire Size Range Cu/Al 60 °C or 75 °C for Main Breaker	Loadcenter Catalog Number with Combination Cover ②③
		Spaces	Circuits				
BR 10 kAIC	100	20	20	Indoor	C2	#4–1/0	BR2020BC100
		30	30	Indoor	D1	#4–1/0	BR3030BC100
BRH 22 kAIC ④	100	30	30	Indoor	D1	#4–1/0	BR3030HC100
		150		30	30	Indoor	G1
CSR 25 kAIC	200	20	40	Indoor	D1	#2–300 kcmil	BR2040BC200
		30	40	Indoor	G1	#2–300 kcmil	BR3040BC200
		40	40	Indoor	L1	#2–300 kcmil	BR4040BC200

#### Main Lug Only Loadcenters—Copper Bus

##### BR816LC125FDP



#### Single-Phase Three-Wire—120/240 Vac—Insulated/Bondable Single Neutral with Copper Bus

Main Ampere Rating	Maximum Number 1-Inch (25.4 mm)		Enclosure Type	Trim Type	Box Size	Wire Size Range Cu/Al 60 °C or 75 °C for Main Lugs	Loadcenter Catalog Number
	Spaces	Circuits					
125	8	16	Indoor	Surface (with door)	7	#14–1	BR816LC125SDP
	8	16	Indoor	Flush (with door)	7		BR816LC125FDP

#### Notes

- ① Series combination rating with Types BD, BR, BQ, BQC and GFTCB is 22 kAIC with BRH main and 25 kAIC with CSR main.
  - ② All main circuit breaker loadcenters are listed for use as service entrance equipment and are shipped with neutral bonding strap preattached. The maximum rating of the panel is the main circuit breaker rating when used as service entrance equipment.
  - ③ Ground bar kits priced separately. See **Page V1-T1-68.**
  - ④ 22 kAIC series combination rating is obtained when Types BD, BR, BQ, BQC and GFTCB 10 kAIC branch breakers are used in series with Type BRH main breaker.
- Box sizes **Pages V1-T1-73** through **V1-T1-76.**

### Convertible Loadcenters—Copper Bus 10/22/25 kAIC

BR3040NC200



### Convertible—Single-Phase, Three-Wire—120/240 Vac—Insulated/Bondable Split Neutral

Main Ampere Rating	Maximum Number 1-Inch (25.4 mm)		Enclosure Type	Box Size	Wire Size Range Cu/Al 60 °C or 75 °C for Main	Loadcenter Catalog Number (With Combination or NEMA Type 3R Cover) ①②③
	Spaces	Circuits				
125 10/22 kAIC ④⑤	12	24	Indoor	B2	See main breaker and main lug kit tables on <b>Page V1-T1-54</b> .	<b>BR1224NC125</b> ⑥⑦
	12	24	Outdoor	B2R		<b>BR1224NC125R</b> ⑥⑦⑧
	20	24	Indoor	C2		<b>BR2024NC125</b> ⑦
	20	24	Outdoor	C3R		<b>BR2024NC125R</b> ⑦⑧
200 10/25 kAIC ④⑤	20	40	Indoor	D1	<b>BR2040NC200</b>	
	20	40	Outdoor	D1R	<b>BR2040NC200R</b> ⑧	
	30	40	Indoor	G1	<b>BR3040NC200</b>	
	30	40	Outdoor	G1R	<b>BR3040NC200R</b> ⑧	
	40	40	Indoor	L1	<b>BR4040NC200</b>	
	40	40	Outdoor	L1R	<b>BR4040NC200R</b> ⑧	

#### Notes

- ① 100, 125 and 200 A convertible base unit catalog numbers include interior, box and cover only. Main devices and accessories must be ordered separately for field installation. All convertible base units are listed as suitable for use as service entrance equipment when used per Article 384 of the NEC.
- ② Ground bar kits priced separately, refer to **Page V1-T1-68**.
- ③ All main circuit breaker loadcenters are listed for use as service entrance equipment and are shipped with a neutral bonding strap preattached. The maximum main rating of the loadcenter is the main breaker rating when used as service entrance equipment.
- ④ Interrupting rating depends on main circuit breaker selected. See **Page V1-T1-68** for mains.
- ⑤ For main breaker, use Type BW or CSR. For main lug, use Type BRL.
- ⑥ Rainproof loadcenters are furnished with hub closure plates. For rainproof hubs, refer to **Page V1-T1-68**.
- ⑦ Hold-down screw BREQS125 comes with loadcenter for back-fed Types BR and BRH main circuit breakers.
- ⑧ For main breaker, use Type BR. For main lug, use Type BRSF.
- ⑨ Suitable for use as service equipment when not more than six main disconnecting means are provided and when not used as a lighting and appliance panelboard.

#### 1 Three-Phase—Type BR Main Circuit Breaker Loadcenters

#### Three-Phase, Four-Wire—Main Lug Loadcenters—Copper Bus—208Y/120 Vac or 240 Vac, Insulated/Bondable Split Neutral

Main Ampere Rating	Maximum Number 1-Inch (25.4 mm)		Enclosure Type	Box Size	Wire Size Range Cu/Al 60 °C or 75 °C for Main	Loadcenter Catalog Number (With Combination or NEMA Type 3R Cover)
	Spaces	Circuits				
125	12	24	Indoor	C1	#6–3/0	3BR1224LC125
125	12	24	Outdoor	C1R	#6–3/0	3BR1224LC125R
150	24	42	Indoor	D1	#4–300 kcmil	3BR2442LC150
150	24	42	Outdoor	D1R	#4–300 kcmil	3BR2442LC150R
200	12	24	Indoor	C4	#4–300 kcmil	3BR1224LC200
200	12	24	Outdoor	C3R	#4–300 kcmil	3BR1224LC200R
200	30	42	Indoor	G1	#4–300 kcmil	3BR3042LC200
200	30	42	Outdoor	G1R	#4–300 kcmil	3BR3042LC200R
200	42	42	Indoor	L1	#4–300 kcmil	3BR4242LC200
200	42	42	Outdoor	L1R	#4–300 kcmil	3BR4242LC200R
225	30	42	Indoor	L1	#4–300 kcmil	3BR3042LC225
225	30	42	Outdoor	L1R	#4–300 kcmil	3BR3042LC225R
400	42	42	Indoor	24	(2) 3/0–250 kcmil	3BR4242LC400S
	42	42	Outdoor	47		3BR4242BC400R
600	42	42	Indoor	24	(2) 3/0–500 kcmil	3BR4242LC600S

#### Three-Phase, Four-Wire—Main Circuit Breaker Loadcenters—Copper Bus—208Y/120 Vac or 240 Vac, Insulated/Bondable Split Neutral

Main Breaker Type	Main Ampere Rating	Maximum Number 1-Inch (25.4 mm)		Enclosure Type	Box Size	Wire Size Range Cu/Al 60 °C or 75 °C for Main Breaker	Loadcenter Catalog Number (With Combination or NEMA Type 3R Cover)
		Spaces	Circuits				
BR 10 kAIC	100	12	24	Indoor	C1	#14–1/0	3BR1224BC100
	100	12	24	Outdoor	C1R	#14–1/0	3BR1224BC100R
CC 10 kAIC	150	30	42	Indoor	L1	#6–4/0	3BR3042BC150
	150	30	42	Outdoor	L1R	#6–4/0	3BR3042BC150R
	200	42	42	Indoor	L2	2/0–300 kcmil	3BR4242BC200
	200	42	42	Outdoor	L2R	2/0–300 kcmil	3BR4242BC200R
	225	42	42	Indoor	L2	2/0–300 kcmil	3BR4242BC225
	225	42	42	Outdoor	L2R	2/0–300 kcmil	3BR4242BC225R
DK 22 kAIC	400	42	42	Indoor	24	(2) 3/0–250 kcmil	3BR4242BC400S
		42	42	Outdoor	47		3BR4242BC400R
HLD 10 kAIC	600	42	42	Indoor	24	(2) 3/0–500 kcmil	3BR4242BC600S

3BR4242B200



#### Three-Phase, Four-Wire—Main Circuit Breaker Loadcenters—Aluminum Bus—208Y/120 Vac or 240 Vac Insulated/Bondable Split Neutral

Main Breaker Type	Main Ampere Rating	Maximum Number 1-Inch (25.4 mm)		Enclosure Type	Box Size	Wire Size Range Cu/Al 60 °C or 75 °C for Main Breaker	Loadcenter Catalog Number <sup>(1)(2)</sup> (With Combination or NEMA Type 3R Cover)
		Spaces	Circuits				
BR 10 kAIC	100	12	24	Indoor	C1	#14–1/0	3BR1224B100
		12	24	Outdoor	C1R		3BR1224B100R <sup>(3)</sup>
CC 10 kAIC	125	30	42	Indoor	L1	#6–4/0	3BR3042B125
		30	42	Outdoor	L1R		3BR3042B150R <sup>(3)</sup>
	200	30	42	Indoor	L1	#1–250 kcmil	3BR3042B200
		30	42	Outdoor	L1R		3BR3042B200R <sup>(3)</sup>
		42	42	Indoor	L2		3BR4242B200
		42	42	Outdoor	L2R		3BR4242B200R <sup>(3)</sup>
CHH 100 kAIC	200	42	42	Indoor	L2	2/0–300 kcmil	3BR4242H200 <sup>(6)</sup>
CC 10 kAIC	225	42	42	Indoor	L2	2/0–300 kcmil	3BR4242B225
		42	42	Outdoor	L2R		3BR4242B225R <sup>(3)</sup>
DK <sup>(4)</sup> 22 kAIC	400	42	42	Indoor	24	(2) #3/0–250 kcmil	3BR4242B400S <sup>(7)</sup>
		42	42	Indoor	24		3BR4242B400F
		42	42	Outdoor	47		3BR4242B400R <sup>(3)</sup>
LD <sup>(5)</sup>	600	42	42	Indoor	24	(2) #3/0–500 kcmil	3BR4242B600F

#### Notes

- <sup>(1)</sup> All main circuit breaker loadcenters are listed for use as service entrance equipment and are shipped with a neutral bonding strap pre-attached (commercial loadcenters do not have a pre-attached bonding strip). The maximum main rating of the panel is the main circuit breaker rating when used as service entrance equipment.
- <sup>(2)</sup> Ground bar kits priced separately. See **Page V1-T1-68**.
- <sup>(3)</sup> Rainproof loadcenters are furnished with hub closure plates. For rainproof hubs, refer to **Page V1-T1-68**.
- <sup>(4)</sup> Type DK main circuit breaker is rated 65 kAIC at 240 Vac and allows a 22 kAIC series rating on the loadcenter when Types BR, BD and BJ branch circuit breakers are used.
- <sup>(5)</sup> The LD main circuit breaker is rated 65 kAIC at 240 Vac. Type LD circuit breaker **is not** series rated with Types BR, BD and BJ branch circuit breakers.
- <sup>(6)</sup> Includes CHH 100 kAIC rated MCB. 100 kAIC series rating combination is obtained when types BD, BR, BQ, BQC and GFGB branch breakers are used with CHH main.
- <sup>(7)</sup> With surface cover.

### 3BR1224L125



### Three-Phase, Four-Wire—Main Lug Loadcenters—Aluminum Bus—208Y/120 Vac or 240 Vac, Insulated/Bondable (Unless Otherwise Noted)

Main Ampere Rating	Maximum Number 1-Inch (25.4 mm)		Enclosure Type	Box Size	Wire Size Range Cu/Al 60 °C or 75 °C for Main Lugs	Loadcenter Catalog Number <sup>①</sup> (With Combination or NEMA Type 3R Cover)
	Spaces	Circuits				
100	3	3	Indoor	6	#6–1/0	<b>3BR3L100S</b> <sup>②③</sup>
	3	3	Outdoor	6R		<b>3BR3L100R</b> <sup>③④</sup>
125	12	24	Indoor	C1	#6–3/0	<b>3BR1224L125</b> <sup>⑤⑥</sup>
	12	24	Outdoor	C1R		<b>3BR1224L125R</b> <sup>④⑤⑥</sup>
150	18	36	Indoor	C2	#6–4/0	<b>3BR1836L150</b>
	18	36	Outdoor	C3R		<b>3BR1836L150R</b>
	24	42	Indoor	D1	#4–300 kcmil	<b>3BR2442L150</b>
	24	42	Outdoor	D1R		<b>3BR2442L150R</b> <sup>④</sup>
200	12	24	Indoor	C4	#4–300 kcmil	<b>3BR1224L200</b> <sup>⑥</sup>
	12	24	Outdoor	C3R		<b>3BR1224L200R</b> <sup>④⑥</sup>
	18	36	Indoor	C4	#4–300 kcmil	<b>3BR1836L200</b>
	18	36	Outdoor	C3R		<b>3BR1836L200R</b>
	30	42	Indoor	G1	#4–300 kcmil	<b>3BR3042L200</b>
	30	42	Outdoor	G1R		<b>3BR3042L200R</b> <sup>④</sup>
	42	42	Indoor	L1	#4–300 kcmil	<b>3BR4242L200</b>
	42	42	Outdoor	L1R		<b>3BR4242L200R</b> <sup>④</sup>
225	42	42	Indoor	L1	#4–300 kcmil	<b>3BR4242L225</b>
	42	42	Outdoor	L1R		<b>3BR4242L225R</b> <sup>④</sup>

### 3BR4242L400F



### Three-Phase, Four-Wire—Main Lug Loadcenters—Aluminum Bus—208Y/120 Vac or 240 Vac, Insulated/Bondable Split Neutral

Main Ampere Rating	Maximum Number 1-Inch (25.4 mm)		Enclosure Type	Box Size	Wire Size Range Cu/Al 60 °C or 75 °C for Main Lugs	Commercial Loadcenter Catalog Number <sup>⑦</sup>	
	Spaces	Circuits				With Flush or NEMA Type 3R Cover	With Surface Cover
400	42	42	Indoor	22	(1) 250–750 kcmil	<b>3BR4242L400F</b>	<b>3BR4242L400S</b>
	42	42	Outdoor	46	or (2) #3/0–250 kcmil	<b>3BR4242L400R</b> <sup>④</sup>	—
600	42	42	Indoor	22	(2) #2–500 kcmil	—	<b>3BR4242L600S</b>

#### Notes

- ① Ground bar kits priced separately. See **Page V1-T1-68**.
- ② Surface cover only.
- ③ Insulated/bondable single neutral.
- ④ Rainproof loadcenters are furnished with hub closure plates. For rainproof hubs, refer to **Page V1-T1-68**.
- ⑤ Has notch for BREQS125 hold-down kit.
- ⑥ Suitable for use as service equipment when not more than six main disconnecting means are provided and when not used as a lighting and appliance panelboard.
- ⑦ Door lock and key included with loadcenter.

Box sizes **Pages V1-T1-73** through **V1-T1-76**.

# 1.2

## Loadcenters and Circuit Breakers

### Type BR Loadcenters and Circuit Breakers

1

3BR3030N100



3BR4242N225NY



### Three-Phase, Four-Wire—Convertible Loadcenters—Aluminum Bus—208Y/120 Vac or 240 Vac, Insulated/Bondable Split Neutral

Main Ampere Rating <sup>①</sup>	Maximum Number 1-Inch (25.4 mm)		Enclosure Type	Box Size	Wire Size Range Cu/Al 60 °C or 75 °C for Main	Loadcenter Catalog Number <sup>②③</sup> (With Combination or NEMA Type 3R Cover)
	Spaces	Circuits				
100 <sup>④</sup>	30	30	Indoor	D1	See main breaker and main lug kit tables below.	3BR3030N100 <sup>⑤</sup>
	30	30	Outdoor	D1R		3BR3030N100R <sup>⑥⑦</sup>
125 <sup>④</sup>	12	24	Indoor	C1		3BR1224N125 <sup>⑤⑥⑦</sup>
	12	24	Outdoor	C1R		3BR1224N125R <sup>⑤⑥⑦⑧</sup>
200	30	42	Indoor	L1		3BR3042N200
225	42	42	Indoor	L2		3BR4242N225
	42	42	Indoor	B		3BR4242B225NY <sup>⑨</sup>

#### Notes

- ① The maximum rating of the loadcenter is the main circuit breaker rating when used as service entrance equipment.
- ② 100, 125 and 200 A convertible base unit catalog numbers include interior, box and cover only. Main devices and accessories must be ordered separately for field installation.  
All convertible base units are listed as suitable for use as service entrance equipment when used per Article 384 of the NEC.
- ③ Ground bar kits priced separately. See **Page V1-T1-68**.
- ④ For main breaker, use Type BR. For main lug, use Type BRSF.
- ⑤ BREQS125 hold-down screw comes with loadcenter for back-fed Types BR and BRH main circuit breakers.
- ⑥ Rainproof loadcenters are furnished with hub closure plates. For rainproof hubs, refer to **Page V1-T1-68**.
- ⑦ Convertible to maximum of 100 A main circuit breaker and 125 A main lug.
- ⑧ Suitable for use as service equipment when not more than six main disconnecting means are provided and when not used as a lighting and appliance panelboard.
- ⑨ Order 3BR42FTNY or 3BR42STNY cover separately.

Box sizes **Pages V1-T1-73 through V1-T1-76**.

### BR Quick Connect Neutral Loadcenters



### Contents

<i>Description</i>	<i>Page</i>
Overview .....	V1-T1-42
BR Specialty Products	
BR Quick Connect Neutral Loadcenters	
Spa Panels .....	V1-T1-58
Riser Panel .....	V1-T1-59
Type BR Renovation Loadcenter .....	V1-T1-60
BR Loadcenter Options and Accessories .....	V1-T1-63
BR Circuit Breakers .....	V1-T1-77

## BR Specialty Products

### BR Quick Connect Neutral Loadcenters

#### Product Description

The Type BR Quick Connect Neutral loadcenters coupled with Type BR Quick Connect Neutral electronic breakers provide a clean, quick connection for an installer looking to save time while providing a professional look.

#### Features and Benefits

- Full-length neutral bars provide over 300% neutral capacity while enhancing installation flexibility for the installer
- Backed-out neutral screws allow an installer to make a quick connection when terminating neutral and ground wires
- Extended circuits (30/60, 40/80) provide maximum flexibility to a contractor on every space possible
- Standard LED diagnostics on AFCI and AF/GF breakers provides installers best-in-class troubleshooting technology
- Cut-to-length neutral wires provides a clean, professional look versus traditional pigtail circuit breakers
- Solid-tip, stranded neutral wires provide a quick connection to the full length neutral bar

## Product Selection

### BR Quick Connect Neutral Loadcenters ①

Main Device	Ampere Rating	Spaces	Circuits ②	Incoming Lug Size	Enclosure Type ③	Box Size	Ground Bar	Number of Neutral Terminations	Catalog Number
BR 10 kAIC	100	30	60	#4-1/0	Indoor	D1	④	96	BR3060BQN100
CSR 25 kAIC	150	30	60	#2-300 kcmil	Indoor	G1	④	102	BR3060BQN150
CSR 25 kAIC	200	30	60	#2-300 kcmil	Indoor	G1	④	102	BR3060BQN200
CSR 25 kAIC	200	40	80	#2-300 kcmil	Indoor	L1	④	128	BR4080BQN200
CSR 25 kAIC	200	30	60	#2-300 kcmil	Outdoor	L1R	④	94	BR3060BQN200R
CSR 25 kAIC	200	40	80	#2-300 kcmil	Outdoor	G1R	④	128	BR4080BQN200R
Main lug only	125	24	48	#6-2/0	Indoor	C2	GBK14	80	BR2448LQN125G
Main lug only	125	30	60	#6-2/0	Indoor	D1	GBK10	96	BR3060LQN125G
Main lug only	200	30	60	#1-300 kcmil	Indoor	D1	GBK1020 + GBK10	96	BR3060LQN200G
Main lug only	200	40	80	#1-300 kcmil	Indoor	G1	GBK1020 + GBK10	122	BR4080LQN200G
Main lug only	125	20	40	#6-2/0	Outdoor	C1R	GBK14	68	BR2040LQN125RG
Main lug only	200	30	60	#1-300 kcmil	Outdoor	D1R	GBK1420	94	BR3060LQN200RG
Convertible	200	30	60	—	Indoor	G1	④	102	BR3060NQN200
Convertible	200	40	80	—	Indoor	L1	④	128	BR4080NQN200
Convertible	200	30	60	—	Outdoor	G1R	④	94	BR3060NQN200R
Convertible	200	40	80	—	Outdoor	L1R	④	128	BR4080NQN200R

### BR Quick Connect Neutral Electronic Breakers

Ampere Rating	Poles	Wire Size	Breaker Type	LED Diagnostics Included	Catalog Number
15	Single-pole 10 kAIC	#14-4	Combination AFCI	Yes	BRCAF115QN
20	Single-pole 10 kAIC	#14-4	Combination AFCI	Yes	BRCAF120QN
15	Single-pole 10 kAIC	#14-4	Arc fault/ground fault	Yes	BRLAFGF115QN
20	Single-pole 10 kAIC	#14-4	Arc fault/ground fault	Yes	BRLAFGF120QN

#### Notes

- ① BR Quick Connect Neutral loadcenters accept both standard and Quick Connect Neutral breakers.
- ② Loadcenters accept Type BR twin breakers.
- ③ Combination cover included with every indoor loadcenter.
- ④ Ground bar kit not included. Purchase separately.

#### Spa Panels



### Spa Panels

#### Product Description

Eaton's BR Spa Panels distribute power to outdoor loads and provide protection for people from electric shock. Save time and money with streamlined installation procedures and easy-access features. Spa panels meet NEC requirements by providing a ground fault circuit interruption device and a disconnect switch in a single simple device. Ships assembled prewired, factory tested and ready to install.

#### Features

- 10-year warranty
- UL Listed
- Factory-installed two-pole ground fault circuit interrupter (GFCI)

#### Product Selection

BR Spa Panel



#### Spa Panel—Meets NEC Article 680.40 Through 680.43—Requirements for GFCI Protection

Main Ampere Rating	Maximum Number 1-Inch (25.4 mm) Space Poles		Enclosure Type	Box Size	Wire Size Range Cu/Al 60 °C or 75 °C for Main Lugs	Catalog Number
40	—	—	Outdoor	5R	#8-#2	BR40SPAST <sup>①</sup>
50	—	—	Outdoor	5R	#8-#2	BR50SPAST <sup>②</sup>

#### Notes

- ① Includes a GFTCB240 breaker, factory installed.
- ② Includes a GFTCB250 breaker, factory installed.

### Contents

Description	Page
Overview . . . . .	V1-T1-42
BR Specialty Products	
BR Quick Connect Neutral Loadcenters . . . . .	V1-T1-57
Spa Panels	
Riser Panel . . . . .	V1-T1-59
Type BR Renovation Loadcenter . . . . .	V1-T1-60
BR Loadcenter Options and Accessories . . . . .	V1-T1-63
BR Circuit Breakers . . . . .	V1-T1-77

### Riser Panel



### Contents

<i>Description</i>	<i>Page</i>
Overview .....	<b>V1-T1-42</b>
BR Specialty Products	
BR Quick Connect Neutral Loadcenters .....	<b>V1-T1-57</b>
Spa Panels .....	<b>V1-T1-58</b>
Riser Panel	
Type BR Renovation Loadcenter .....	<b>V1-T1-60</b>
BR Loadcenter Options and Accessories .....	<b>V1-T1-63</b>
BR Circuit Breakers .....	<b>V1-T1-77</b>

## Riser Panel

### Product Description

Eaton's Riser Panel is a loadcenter with an offset interior to allow riser cables to pass through the enlarged gutter. By using lay-in tap lugs, the contractor is able to simply strip off a length of the riser cable's insulation, and tap off to the riser panel's main lugs. These panels are used in the construction of assisted living homes, dormitories, public housing complexes and apartments.

### Product Selection

#### BR1224L125RIS



#### Riser Panel

Main Ampere Rating	Maximum Number 1-Inch (25.4 mm)		Enclosure Type	Box Size	Wire Size Range Cu/Al 60 °C or 75 °C for Main Lugs	Catalog Number
	Space	Circuits				
125	12	24	Indoor	C4	#6-2/0	<b>BR1224L125RIS</b>
125	12	24	Indoor	C4	#6-2/0	<b>BR1224L125RISBP</b> ①
125	20	24	Indoor	C4	#6-2/0	<b>BR2024L125RIS</b>
125	20	24	Indoor	C4	#6-2/0	<b>BR2024L125RISBP</b> ①
125	20	30	Indoor	C2	#6-2/0	<b>BR2030L125RIS</b>
200	30	40	Indoor	D1	#1-300	<b>BR3040L200RIS</b>

#### BRGUTTER (Shown with Loadcenter)



#### Riser Panel Accessories

##### Catalog Number

**BRGUTTER** ②

**GTAP250**

#### Notes

- ① Bulk-packaged loadcenter without carton. Must be ordered in multiples of 16.
- ② Refer to **Page V1-T1-74** for dimensions. BRGUTTER is box size C2.

### Accessories

For riser panels not shown, contact the Flex Center at 1-800-330-6479 for both CH and BR riser panels.



#### BR Renovation Loadcenters

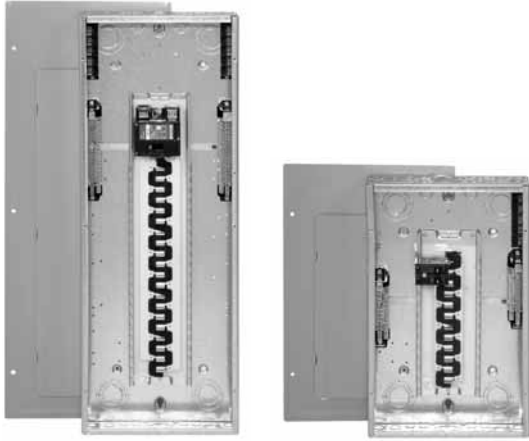

#### Contents

<i>Description</i>	<i>Page</i>
Overview .....	V1-T1-42
BR Specialty Products	
BR Quick Connect Neutral Loadcenters .....	V1-T1-57
Spa Panels .....	V1-T1-58
Riser Panel .....	V1-T1-59
Type BR Renovation Loadcenter	
BR Loadcenter Options and Accessories.....	V1-T1-63
BR Circuit Breakers .....	V1-T1-77

### Type BR Renovation Loadcenter

#### Product Description

- Available in 10, 20, 30 and 40 circuit main breaker styles
- Designed to replace existing loadcenters and fuse boxes
- Type BR loadcenter packaged with circuit breakers
- Factory-installed 5-circuit terminal block(s)
- Twin-stacked neutral design

#### Features, Benefits and Functions

- Factory-installed terminal block(s) allows installer to terminate existing short wires without using wire nuts or junction boxes
- Twin-stacked neutrals are mounted up high in the loadcenter, which allows for all neutral and ground wires to be terminated in the top half of the loadcenter
- Specifically designed for the service contractor—this is the ONLY renovation line in the industry
- Single-pole and two-pole breakers included
- 10-year warranty on loadcenter and breakers

#### Product Selection

##### BR2020B100RN



#### BR Value Packs ①

Main Breaker Type	Description	Wire Size Range	Number of 5-Circuit Terminal Blocks	Single-Pole Breakers	Two-Pole Breakers	Catalog Number
BR 10 kAIC	Single-phase 100 A 10k main breaker 10/20 circuit surface-mount box is 11.75" wide x 13" tall	#6-1/0	0	(2) BR115	(1) BR230	<b>BR1020B100SRNV</b>
	Single-phase 100 A 10k main breaker 10/20 circuit flush-mount box is 11.75" wide x 13" tall		0	(2) BR115	(1) BR230	<b>BR1020B100FRNV</b>

#### Note

① Indoor enclosure type.

Type BR Retrofit Interior



Type BR Retrofit Adjustable Interior



Type BR Retrofit Interior Collar and Assembly with Trim

### Contents

<b>Description</b>	<b>Page</b>
Overview .....	V1-T1-42
BR Specialty Products	
BR Quick Connect Neutral Loadcenters .....	V1-T1-57
Spa Panels .....	V1-T1-58
Riser Panel .....	V1-T1-59
Type BR Renovation Loadcenter .....	V1-T1-60
BR Loadcenter Options and Accessories	
Type BR Retrofit Interior Kits	
BR Specialty Product Selection .....	V1-T1-62
Type BR Mechanical Interlock Kits .....	V1-T1-65
Technical Data and Specifications .....	V1-T1-70
Dimensions .....	V1-T1-73
BR Circuit Breakers .....	V1-T1-77

## Type BR Retrofit Interior Kits

### Product Description

Eaton's unique Retrofit Interior allows the customer to cost-effectively and safely upgrade an electrical service without removing the existing enclosure from the wall.

### Application Description

The Retrofit Interior is designed and tested specifically for renovating an outdated electrical panel in an apartment, a condominium or a single family home. These outdated panels are being recognized by local inspectors and other authorities as a possible hazard.

#### Opportunities to Retrofit

- Single- or three-phase
- Main lug only or main breaker
- Up to 42 circuits
- Up to 225 A interiors, 400 A available upon request
- Available with CH breakers (3/4-inch) with copper bus or BR breakers (1-inch) with aluminum bus
- The minimum lifetime warranty for residential breakers shall be as follows:
  - 10-year warranty on all BR branch breakers and loadcenters
  - Refer to Eaton for complete warranty details

### Features and Benefits

#### Upgrading Existing Electrical Infrastructure Is Simple

- Replaces vintage brands that have hard to find, expensive replacement breakers
- Safety upgrade to arc fault and ground fault breakers to meet current electrical codes
- Maximizes number of circuits available with compact design
- Eco-friendly in asbestos-filled environments
- Exclusive design

#### Save Time and Money Throughout the Installation

- Uses existing panel box and wires
- Eliminates expensive and time-consuming drywall/paint repair
- Saves 2–3 hours of installation time compared to a complete panel changeout
- Eliminates precise measurements with field-adjustable kit

### Standards and Certifications

- Meets 2017 NEC wire bending requirements
- UL 67 Listed (for UL listings for specific part numbers, see the table on the following page.)



#### 1

### BR Specialty Product Selection

To select the retrofit kit:

1. From the existing box size determine which retrofit groups are suitable (may be more than one).
2. Use type of interior, number of phases, and type of main to find the selection chart.
3. Select part number from chart (if main breaker, replace XXX with specific amp rating).

#### How to Order:

1. Measure the existing panel enclosure to determine appropriate kits for your project.
2. Match the existing dimensions with the table below to obtain the correct catalog number.
3. Order your retrofit kit from a local Eaton authorized distributor.

Need assistance or can't find retrofit to fit existing enclosure?

Call Eaton's Residential Flex Center at 1-800-330-6479 or email for all your retrofit needs. Go to [www.eaton.com/eccn](http://www.eaton.com/eccn) to locate an Eaton Certified Contractor.

### Retrofit Interior Kit Specifications

Five recommended groups: existing box height determines retro group size. Approximate Dimensions in Inches (mm).

Catalog Number ①	Cover ②	Existing Enclosure Parameters—Inches (mm)				Phase	Main	Bus	Amperes ③	Spaces / Circuits	UL 67 Listed
		Minimum Depth	Maximum Depth	Minimum Width	Minimum Height						
<b>BR Retrofit Interiors and Covers</b>											
RTBR8L100P	CRTBR8ML****	3.13 (79.5)	3.63 (92.2)	10.50 (266.7)	13.00 (330.2)	Single	MLO	BR	100	8/16	Yes
RUBR8L100_	CRUBR8ML****	3.75 (95.3)	6.00 (152.4)	10.50 (266.7)	13.00 (330.2)	Single	MLO	BR	100	8/16	Yes
RTBR12L100P	CRTBR12ML****	3.13 (79.5)	3.63 (92.2)	10.50 (266.7)	14.50 (368.3)	Single	MLO	BR	100	12/24	Yes
RTBR10B100P	CRTBR12ML****	3.13 (79.5)	3.63 (92.2)	10.50 (266.7)	14.50 (368.3)	Single	MLO	BR	100	10/20	Yes
RUBR12L100_	CRUBR12ML****	3.75 (95.3)	6.00 (152.4)	10.50 (266.7)	14.50 (368.3)	Single	MLO	BR	100	12/24	Yes
RUBR10B100_	CRUBR12ML****	3.75 (95.3)	6.00 (152.4)	10.50 (266.7)	14.50 (368.3)	Single	MB	BR	100	10/20	Yes
RTBR12L125P	CRTBR12ML****	3.13 (79.5)	3.63 (92.2)	11.00 (279.4)	17.00 (431.8)	Single	MLO	BR	125	12/24	Yes
RTBR10B125P	CRTBR12ML****	3.13 (79.5)	3.63 (92.2)	11.00 (279.4)	17.00 (431.8)	Single	MB	BR	125	10/20	Yes
RUBR12L125_	CRUBR12ML****	3.75 (95.3)	6.00 (152.4)	11.00 (279.4)	17.00 (431.8)	Single	MLO	BR	125	12/24	Yes
RUBR10B125_	CRUBR12ML****	3.75 (95.3)	6.00 (152.4)	11.00 (279.4)	17.00 (431.8)	Single	MB	BR	125	10/20	Yes
RABR20B125_	CRABR20ML****	3.75 (95.3)	6.00 (152.4)	13.00 (330.2)	21.00 (533.4)	Single	MCB	BR	125	20/24	No
RABR20L125_	CRABR20ML****	3.75 (95.3)	6.00 (152.4)	13.00 (330.2)	21.00 (533.4)	Single	MLO	BR	125	20/24	No
RBBR20B200_	CRBBR20BW****	3.75 (95.3)	6.00 (152.4)	13.00 (330.2)	29.00 (736.6)	Single	MLO	BR	200	20/40	No
RCBR40L200_	CRCBR40ML****	3.75 (95.3)	6.00 (152.4)	13.00 (330.2)	34.00 (863.6)	Single	MLO	BR	200	30/40	No
RDBR40B200_	CRDBR40BW****	3.75 (95.3)	6.00 (152.4)	13.00 (330.2)	37.00 (939.8)	Single	MLO	BR	200	40/40	No

### Complete Assembly

**Note:** For complete assembly, interior and cover need to be ordered separately.

#### Adjustable Interior

- Factory installed ground and neutral bars positioned to accept existing wires
- Field adjustable depth matches existing panel box
- Adjustable height enables optional placement of the interior
- Field bondable for service entrance options



Adjustable Interior

#### Standard Trim and Collar

- Standard trim matches new interior
- New circuit directory for updated labeling
- Oversized collar eliminates expensive wall/paint repair



Collar and Assembly with Trim

#### Notes

- ① Catalog numbers shown with "\_" at the end need one of the following suffixes to denote depth:  
J = 3.75–4.25  
K = 4.25–5.00  
L = 5.00–6.00  
Example: RUBR12L125J would signify an interior set with a depth range of 3.75 to 4.25 inches.
- ② \*\*\*\* Denotes characters in the catalog number that relate to overall cover size.  
Example: CRTBR12ML2620 would signify a cover 26.00 inches H x 20.00 inches W.
- ③ Amperes for MB panels is maximum; catalog number will reflect actual amperage of breaker included.

For UL applications, maximum cover sizes may apply.

### Options and Accessories—Mechanical Interlocks



### Contents

Description	Page
Overview	V1-T1-42
BR Specialty Products	
BR Quick Connect Neutral Loadcenters	V1-T1-57
Spa Panels	V1-T1-58
Riser Panel	V1-T1-59
Type BR Renovation Loadcenter	V1-T1-60
BR Loadcenter Options and Accessories	
Type BR Retrofit Interior Kits	V1-T1-61
Type BR Mechanical Interlock Kits	V1-T1-65
Technical Data and Specifications	V1-T1-70
Dimensions	V1-T1-73
BR Circuit Breakers	V1-T1-77

## BR Loadcenter Options and Accessories

### Product Selection

#### BRSF125



#### 3BRS225



#### BRL200



#### TDL



### Field Installation Kits and Parts

Number of Poles	Ampere Rating	Number of 1-Inch (25.4 mm) Spaces Needed	Wire Size Range Cu/Al 60 °C or 75 °C	Ordering Quantity <sup>①</sup>	Catalog Number
<b>Main and Sub-Feed Lug Blocks</b>					
2	125	2	#8–2/0	1	<b>BRSF125</b>
	150	2	#8–2/0	1	<b>BRSF150</b> <sup>②</sup>
	225	4	#2–300 kcmil	1	<b>BRS225</b>
3	150	3	#8–2/0	1	<b>3BRSF150</b> <sup>②</sup>
	225	6	#2–300 kcmil	1	<b>3BRS225</b>
<b>Main Lugs</b>					
Two-pole, 200 A stud mounted (includes deadfront filler plate)			#1–300 kcmil	1	<b>BRL200</b>
Neutral/ground lug Add-on neutral or ground lug			#2/0 maximum	1	<b>NL20</b>
			#3/0 maximum	1	<b>NL30</b>
			300 kcmil maximum	1	<b>NL300</b>
<b>Filler Plates</b>					
1-inch (25.4 mm) circuit breaker space				25	<b>BRFP</b>
BW main circuit breaker space (with hardware)				1	<b>BWFP</b>
Door lock—12–42 circuits, and 100–225 A				1	<b>TDL</b>
Door lock—4–8 circuits, 125 A				1	<b>CH9FL</b>
ANSI-61 light gray touchup paint for current loadcenters				1	<b>SPC61</b>
Isolated neutral assembly (computer circuits)				1	<b>BINA</b>
Circuit directory—adhesive backed				10	<b>TCD</b>
Cover screws				25	<b>LCCS</b>
Cover replacement latch (gray) 14-5/16 (363.5 mm) wide loadcenters only				1	<b>BRRL</b>
Circuit marking strip (next to breaker)				10	<b>BRMS</b>
Circuit identification label (preprinted breaker labels)				25	<b>CHBL</b>
Series rated caution label				25	<b>SRL</b>
Bonding strip with screw				1	<b>BSSUSE</b>

#### Notes

- <sup>①</sup> Must be purchased in multiples of ordering quantities indicated.
- <sup>②</sup> #8–2/0 wire size range is 75 °C rated only.

**Three-Phase Accessories****Three-Phase Main Breaker Kits— 10 kAIC**

<b>Ampere Rating</b>	<b>Wire Size Range Cu/Al 60 °C or 75 °C</b>	<b>Catalog Number</b>
100	#6–4/0	<b>CC3100N</b>
125	#6–4/0	<b>CC3125N</b>
150	#6–4/0	<b>CC3150N</b>
175	#2/0–300 kcmil	<b>CC3175N</b>
200	#2/0–300 kcmil	<b>CC3200N</b>
225	#2/0–300 kcmil	<b>CC3225N</b>

**Three-Phase Main Lugs Kit for Convertible Loadcenters**

<b>Ampere Rating</b>	<b>Wire Size Range Cu/Al 60 °C or 75 °C</b>	<b>Catalog Number</b>
225	#1–300 kcmil	<b>3BRL225</b>
225	#1–300 kcmil	<b>3BRS225</b> ①

**Note**

① For subfeed.

Box sizes **Pages V1-T1-73 through V1-T1-76.**

### Type BR Mechanical Interlock Kits



**Type BR Loadcenter with Mechanical Interlock Kit**

### Type BR Mechanical Interlock Kits

#### Product Description

With the aging electrical infrastructure and frequent severe storms, power outages are becoming more and more frequent, affecting thousands of people nationwide. Eaton mechanical interlock kit provides an easy and cost-effective solution when using backup emergency power.

This solution expands the robust line of emergency power products and accessories.

#### Features and Benefits

- Prevents utility and generator supplies from being on at the same time
- Protects utility linemen from dangerous generator backfeed
- Robust interlock design
- Offered in two unique styles for almost any BR loadcenter, which can reduce inventory levels
- Quick and easy installation—drill points or fixtures for pilot holes are provided on all applicable BR loadcenters; no additional assembly is required

### Contents

#### Description

	<i>Page</i>
Overview .....	<b>V1-T1-42</b>
BR Specialty Products	
BR Quick Connect Neutral Loadcenters .....	<b>V1-T1-57</b>
Spa Panels .....	<b>V1-T1-58</b>
Riser Panel .....	<b>V1-T1-59</b>
Type BR Renovation Loadcenter .....	<b>V1-T1-60</b>
BR Loadcenter Options and Accessories	
Type BR Retrofit Interior Kits .....	<b>V1-T1-61</b>
Type BR Mechanical Interlock Kits .....	<b>V1-T1-65</b>
Technical Data and Specifications .....	<b>V1-T1-70</b>
Dimensions .....	<b>V1-T1-73</b>
BR Circuit Breakers .....	<b>V1-T1-77</b>

#### Standards and Certifications

- UL 67 Listed—For use with BR loadcenters
- Meets NEC® Article 702



#### Product Selection



Each mechanical interlock kit includes:

- Interlock assembly
- Hold down kit ①
- New labels
- Necessary screws

Warranty information:

- 10-year warranty on all Type BR circuit breakers and loadcenters
- Refer to Eaton for complete warranty details

#### Mechanical Interlock Kits ②

	Description	Catalog Number
	Single	<b>BRMIKBR</b>
	Bulk pack ③	<b>BRMIKBRBP</b>
	Single	<b>BRMIKCSR</b>
	Bulk pack ③	<b>BRMIKCSRBP</b>

#### Notes

- ① For breakers under 70 A used in backfed applications, add "B" to the end of the catalog string to get the appropriate "hold-down" version.
- ② Clamshell packaged.
- ③ Bulk pack contains 10 units, individually packaged.

# 1.2

## Loadcenters and Circuit Breakers

### Type BR Loadcenters and Circuit Breakers

1

#### Mechanical Interlock Cover

Covers mechanically interlock two breakers—Type BW or CSR main breaker with a Type BR branch breaker.

BR816B100



#### Mechanical Interlock Cover

Fits Loadcenter Catalog Numbers	Mechanical Interlock Trim/Deadfront Catalog Numbers	Mechanical Interlock Kit Catalog Numbers
<b>Indoor</b>		
BR816B100	BRCOVC10M	BRMIKBR
BR816N100		
BR1212B100	BRCOVC12M	
BR1220B100		
BR1220H100		
BR1224N125	BRCOVC13M	
BR1616B100	BRCOVC16M	
BR1620B100		
BR1624B100		
BR1624B125	BRCOVC17M	
BR1624N125		
BR2020B100, BR2020BC100 BR2020H100, BR2020HC100	BRCOVC22M	
BR2024H100		
BR2020HC100		
BR2030B100		
BR2040B100		
BR2024B125	BRCOVC23M	
BR2024N125, BR2024NC125		
BR3030B100, BR3030BC100	BRCOVC59M	
BR3030H100, BR3030HC100		
<b>Raintight</b>		
BR1020B100R	BR3RDF1M	Field-installed interlock kits not available for these catalog numbers.
BR1224B100R		
BR1224N125R, BR1224NC125R		
BR1624B100R	BR3RDF2M	
BR1624N125R		
BR2024B100R, BR2024B125R	BR3RDF4M	
BR2024N125R, BR2024NC125R		

BR4040B200



### Mechanical Interlock Cover, continued

Fits Loadcenter Catalog Numbers	Mechanical Interlock Trim/Deadfront Catalog Numbers	Mechanical Interlock Kit Catalog Numbers
<b>Indoor</b>		
BR1630B150	BRCOV16C4FM	BRMIKCSR
BR1224N200		
BR1632B200		
BR1632N200		
BR2030B150	BRCOV20C4FM	
BR2030H150		
BR2040B150		
BR2040B200, BR2040BC200	BRCOV20D1FM	
BR2040H200		
BR2040N200, BR2040NC200		
BR2430B150, BR2430BC150	BRCOV30G1FM	
BR3030B150		
BR3030H150		
BR3040B150		
BR2440B200		
BR2440N200		
BR3040B200, BR3040BC200		
BR3040N200, BR3040NC200		
BR3040H200		
BR4040B200, BR4040BC200	BRCOV40L1FM	
BR4040H200		
BR4040N200, BR4040NC200		
BR4242B225	BRCOV42L2FM	
<b>Raintight</b>		
BR816B150RF	BR3RDF5M ①	
BR816B200RF		
BR816N200RF		
BR1224N200R		
BR2030B150R	BR3RDF11M ①	
BR2040B150R		
BR2040B200R		
BR2040B225R		
BR2040N200R		
BR3030B150R	BR3RDF12M ①	
BR3040B200R		
BR3040N200R		
BR4040B200R	BR3RDF13M ①	
BR4040N200R		
BR48B200RF	BR3RDF14M	
BR4242B225R	BR3RDF15M ①	
<b>Mechanical Interlock Loadcenter Replacement Covers ②</b>		
BR2020B100M, BR2020BC100M	BRCOV20C2FM	Field-installed interlock kits not available for these catalog numbers.
BR2024H100M		
BR3030BC100M	BRCOV30D1FM	

**Notes**

- ① Deadfront only.
- ② Can only be provided as replacement covers for factory-installed mechanically interlock loadcenters.



#### DS300H2



#### Field Installation Rainproof Conduit Hubs

Description	Conduit Size Inches (mm)	Ordering Quantity <sup>①</sup>	Catalog Number
Group 1—for use with 70, 100 and 125 A MLO and MCB loadcenters and circuit breaker enclosures and the following 150 and 200 A panels: BR48B200RF	0.75 (19.1)	1	<b>DS075H1</b>
	1.00 (25.4)	1	<b>DS100H1</b>
	1.25 (31.8)	1	<b>DS125H1</b>
	1.50 (38.1)	1	<b>DS150H1</b>
	2.00 (50.8)	1	<b>DS200H1</b>
Group 2—for use with 150, 200 and 225 A MLO and MCB loadcenters and circuit breaker enclosures except for the following 200 A loadcenters: BR48B200RF. Also for use with 400 and 600 A loadcenters and New York City loadcenters manufactured after November 1, 2005	2.00 (50.8)	1	<b>DS200H2</b>
	2.50 (63.5)	1	<b>DS250H2</b>
	3.00 (76.2)	1	<b>DS300H2</b>
Type H conduit hubs for loadcenters PL0724R and S3100RN	0.75 (19.1)	1	<b>RH75P</b>
	1.00 (25.4)	1	<b>RH100P</b>
	1.25 (31.8)	1	<b>RH125P</b>
	1.50 (38.1)	1	<b>RH150P</b>
Adapter kit—Allows installing a Group 1 hub on devices arranged for Group 2 hubs	—	1	<b>DS900AP</b>
Group 1 small blank hub plate with bump	—	1	<b>DS900CP1</b>
Group 2 Large blank hub plate with bump	—	1	<b>DS900CP2</b>

#### GBK14



#### BRGBK39512



#### Ground Bar Kits

Description (See Legend)	Length Inches (mm)	Ordering Quantity <sup>①</sup>	Catalog Number
●○○○○●	2.54 (64.5)	1	<b>GBK5</b> <sup>②</sup>
●○○○○●■	3.59 (91.2)	1	<b>GBK520</b> <sup>②</sup>
●○○○○●○○○○	4.29 (109.0)	1	<b>GBK10</b> <sup>②</sup>
●○○○○●○○○○■	5.34 (135.6)	1	<b>GBK1020</b> <sup>②</sup>
●○○○○■○○○○	4.61 (117.1)	1	<b>GBK13</b> <sup>②</sup>
●○○○○●○○○○○○○○	5.69 (144.5)	1	<b>GBK14</b> <sup>②</sup>
●○○○○●○○○○○○○○■	6.74 (171.2)	1	<b>GBK1420</b> <sup>②</sup>
●○○○○●○○○○○○○○○○○○	8.14 (206.8)	1	<b>GBK21</b> <sup>②</sup>
●○○○○●○○○○○○○○○○○○■	9.19 (233.4)	1	<b>GBK2120</b> <sup>②</sup>
○□□□●○○○○○□□□○○○○○□	5.78 (146.8)	1	<b>BRGBK39512</b> <sup>③④</sup>
○○○○	1.84 (46.7)	1	<b>GB4NM</b> <sup>⑤</sup>

#### Ground Bar Legend

- (3) #14–10 Cu/Al or (1) #14–4 Cu/Al
- (1) #6–2/0 Cu/Al
- (1) #14–1/0 Cu/Al or (3) #14–10 Cu/Al
- ◐ (1) #14–6 Cu/Al or (2) #14–12 Cu/Al
- Mounting Hole

#### Notes

- ① Must be purchased in multiples of ordering quantities indicated.
- ② Distance between mounting holes is 1.75 inches (44.5 mm).
- ③ For single- and three-phase 400 and 600 A applications.
- ④ Distance between mounting holes is 2.34 inches (59.5 mm).
- ⑤ For non-metallic enclosures. Snaps into molded base.

### Loadcenter Goof Collars

Don't let an ugly drywall problem ruin a beautiful electrical installation.

Eaton's Goof Collar is designed to cover gaps between the finished drywall and loadcenter enclosure.

This is often necessary when upgrading the electrical service and the drywall surrounding the panel is damaged. The collar allows 2 inches of overhang beyond the standard flush trim.

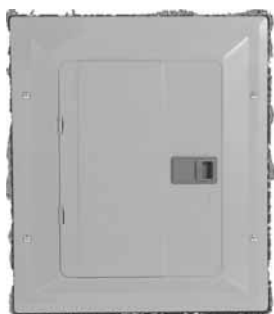

Before



After

### BR Goof Collars

Inches (mm)		Catalog Number	
Height	Width	BR Box Size	Goof Collar
21.00 (533.4)	19.00 (482.6)	<b>B1</b>	<b>BRB1GC2119</b>
23.00 (584.2)	19.00 (482.6)	<b>B2</b>	<b>BRB2GC2319</b>
25.00 (635.0)	19.00 (482.6)	<b>C1</b>	<b>BRC1GC2519</b>
27.00 (685.8)	19.00 (482.6)	<b>C2</b>	<b>BRC2GC2719</b>
31.00 (787.4)	19.00 (482.6)	<b>C4</b>	<b>BRC4GC3119</b>
34.00 (863.6)	19.00 (482.6)	<b>D1</b>	<b>BRD1GC3419</b>
38.00 (965.2)	19.00 (482.6)	<b>G1</b>	<b>BRG1GC3819</b>
43.00 (1092.2)	19.00 (482.6)	<b>L1</b>	<b>BRL1G4319</b>
48.00 (1219.2)	19.00 (482.6)	<b>L2</b>	<b>BRL2GC4819</b>

#### Note

Type BD Duplex, BQ and BQC Quadplex circuit breakers can be installed in Circuit Limiting (CTL) listed BR loadcenters. Type BR twin breakers can be installed in Non-CTL BR loadcenters.

**Technical Data and Specifications****General**

- A. The Contractor shall furnish and install deadfront loadcenters incorporating circuit breakers of the number, rating and type as specified herein and as shown on the contract drawings.
- B. The loadcenter and all components shall be designed, manufactured and tested in accordance with the latest applicable standards of UL, NEMA and NEC including:
  - 1. UL 67—Standards for Panelboards.
  - C. UL 50—Standards for Cabinets and Boxes.
  - D. UL 489—Standards for Molded Case Circuit Breakers.
  - E. UL 869—Standards for Service Equipment.
  - F. Federal Specification W-C 375B—Circuit Breakers.
  - G. Federal Specification W-C P115b—Panel Power Distribution Type 1, Class 2.

**Qualifications**

- A. The manufacturer of the loadcenter shall be the manufacturer of the circuit breaker within the loadcenter.
- B. For the equipment specified herein, the manufacturer shall be ISO 9000 certified.
- C. The manufacturer of this equipment shall have produced similar electrical equipment for a minimum period of seven (7) years.

**Manufacturers**

- A. Eaton.

**Ratings**

- A. Loadcenters shall be rated for 120/240 Vac and shall have short-circuit ratings as shown on the drawings or as herein scheduled, but not less than 10,000 amperes rms symmetrical.
- B. Circuit breakers shall be a minimum of 125 A frame. Circuit breakers 15 through 125 A trip size shall take up the same pole spacing.
- C. Loadcenters shall be labeled with a UL short-circuit rating. When series combination ratings are applied with integral or remote upstream devices, a label shall be provided. Series combination ratings shall cover all trip ratings of installed frames. It shall state the conditions of the UL series ratings including:
  - 1. Size and type of upstream device.
  - 2. Branch devices that can be used.
  - 3. UL series short circuit rating.

**Construction**

- A. All interiors, with the exception of the branch circuit breakers, shall be completely factory assembled with main breakers, main lugs, or no main device.
- B. Interiors shall be designed so that circuit breakers can be replaced without disturbing adjacent units and without removing the main bus connectors and shall be designed so that circuits may be changed without machining, drilling, or tapping.
- C. Physical means shall be provided to prevent the installation of more overcurrent devices than that number for which the enclosure was designed, rated and approved. Half-size breakers shall have a UL listed rejection tab over the line terminals. Loadcenter interiors must have notched stabs to accept these rejection tab class CTL breakers, if required and approved.

**Bus**

- A. Busbars for the main and cross connectors shall be [tin-plated aluminum] [copper] in accordance with Underwriters Laboratories standards. Busing shall be braced throughout to conform to industry standard practice governing short-circuit stresses in loadcenters.

**Note:** Note to spec writer—select one (copper available in limited ratings).

- B. Neutral busing shall have a suitable lug for each outgoing feeder requiring a neutral connection of same ampacity as branch.

**Wiring/Termination**

- A. All wire connectors and terminals shall be of the anti-turn solderless type and shall be suitable for copper or aluminum wire of the sizes indicated. All connectors must meet the "Requirements for Wire Connectors and Soldering Lugs" as stated in UL 486B.
- B. All loadcenters where marked shall be suitable for use with 60 °C or 75 °C rated wire.

**Circuit Breakers**

- A. Circuit breakers shall be molded case type. Circuit breakers shall have four-rivet construction (GFI Type—5 rivets). Multipole circuit breakers shall be of a stack pole design to provide electrical phase isolation.
- B. Each pole of the circuit breaker will provide inverse time delay overload and instantaneous short-circuit protection by means of both thermal and magnetic sensors.
- C. The circuit breaker calibration shall not be affected by environmental changes in relative humidity. The thermal bimetal element shall be welded to the steel frame and calibration shall be set independent of the molded case by computer controlled equipment.
- D. All circuit breakers shall be operated by a toggle-type handle and multipole circuit breakers shall have an internal common trip mechanism. The circuit breakers shall incorporate trip mechanisms that are mechanically trip-free from the handle. The handle position shall provide visual trip indication.
- E. Contacts shall be of non-welding silver alloy.
- F. All circuit breakers shall have the trip rating inscribed on the handle on each circuit breaker pole. Also, unique color-coded cases that indicate the UL listed 10 kA or 22 kA interrupting ratings. Breakers shall be able to be used as main or branch disconnect devices.
- G. Branch circuit breakers may also be used in the 1/2-inch (12.7 mm) per pole ratings that include two-pole 1-inch (25.4 mm) wide modules and four-pole 2-inch (50.8 mm) wide modules. Two-pole circuit breakers must incorporate a common trip mechanism.
- H. Circuit breakers shall be completely enclosed in a molded case of thermoset material. No internal aluminum parts shall be used. All internal ferrous parts shall be plated to prevent corrosion.
- I. All terminals shall be listed for use with copper or aluminum conductors. Terminals shall be of the box lug or clamp type design. The terminals shall meet UL 486B requirements and shall be suitable for use with either 60 °C or 75 °C wire.
- J. The calibrated bimetal assembly shall be mechanically isolated from the load terminal using a flexible braided copper shunt wire, such that movement of the terminals due to twisting and overtorquing does not affect breaker calibration.
- K. Breakers shall be SWD rated and/or HACR rated as required.
- L. Arc Fault Interrupting circuit breakers, (AFI), shall be provided on all 15 and 20 A single-phase 120/240 Vac circuits except those indicated as remote controlled breakers. AFI breakers shall be “Classified for mitigating the effects of arcing faults,” or conforming to UL Standard 1699 and as defined by Article 210.12 Section A of the 1999 NEC Code.

**Surge Protection Devices**

See Volume 1, Tab 2 for complete details on surge protection.

**Enclosures**

- A. Loadcenter shall have NEMA Type 1 general purpose or NEMA Type 3R rainproof enclosures as indicated on the drawings and shall be surface or combination flush/surface mounted except where noted.
- B. Boxes shall be made from galvanized sheet steel having multiple knockouts. Rainproof boxes shall use galvanized steel or an approved coating system which meets or exceeds standards for outdoor NEMA Type 3R enclosures. Boxes shall be of sufficient size to provide at least a minimum code gutter space on all sides.
- C. The deadfront shall have an easy adjustment feature for flush applications.
- D. Boxes shall be factory assembled into a single rigid structure.
- E. Unless otherwise noted on drawings, hinged doors covering all circuit breaker handles shall be included in all trims. Trim doors shall not uncover any live parts in making the circuit breaker handles accessible. If key locks are required, all locks shall be keyed alike.
- F. Combination trims for flush and surface panels shall be flat and shall overlap the box by at least 5/8-inch (15.9 mm) all around. Trims shall be mounted by a screwdriver without the need for special tools.

**Finish**

- A. Trims shall be bonderized and finished with a light gray ANSI-61 enamel. The paint finish shall be of a type to which field applied paint will adhere.

**Factory Testing**

- A. The standard factory tests shall be performed on the equipment provided under this section. All tests shall be in accordance with the latest version of UL and NEMA.

#### BR Loadcenters

##### Description

##### Service

Single-phase, three-wire, 120/240 Vac

Three-phase, four-wire, 208Y/120 Vac  
Three-phase, three-wire, 240 Vac delta

##### Short-Circuit Current Rating

10 kAIC: All single- and three-phase loadcenters 70–225 A, 8 to 42 circuits

25 kAIC: All convertible and factory-installed single-phase loadcenters rated 150 and 200 A using Type CSR main breakers

22 kAIC: All convertible loadcenters using 125 A rated Type BRH main breakers or selected factory installed 125 A rated Type BRH main breaker

##### Main Breaker/Main Lug Loadcenters

Single-phase

Main breaker: 100, 125, 150, 200, 225, 400, 600 A

Main lugs: 70, 125, 150, 200, 225, 400, 600 A

Three-phase

Main breaker: 100, 125, 150, 200, 225, 400, 600 A

Main lugs: 100, 125, 150, 200, 225, 400, 600 A

##### Convertible Loadcenters

Main breaker: single-phase up to 200 A and three-phase up to 225 A

Main lugs: single-phase up to 200 A and three-phase up to 150 A

##### Branch Breakers

Types BR, BRH and BRHH: 10–150 A, single-, two- and three-pole; selected amperage available in switching duty, HACR, shunt trip and high magnetic setting

Type GFTCB: 15–60 A

Types BJ and BJH: 125–225 A; two- and three-pole

Type BD Twin: 10–50 A; two of one-pole; take one 1-inch (25.4 mm) space

Type BQ and BQC Multibreaker: 15–30 A. Two of two-pole or one two-pole and two one-pole; takes two 1-inch (25.4 mm) spaces

Type BRW: 15–30 A; two-pole water heater breakers

Type BRSN: 15–30 A; two-pole switching neutral breakers

Type BR 15–100 A; two-pole, 240 Vac delta breakers

BR-AFCI arc fault circuit interrupter

##### Enclosures

NEMA Type 1 indoor

NEMA Type 3R outdoor

NEMA 4X

Meets or exceeds UL requirements for indoor or outdoor applications

##### Loadcenter and Breaker Accessories

Branch circuit breaker:

Auxiliary components    Hold-down kits    Handle ties

Lockoffs    Lockdogs

Complete line of ground bar kits 5, 10, 14 and 21 circuit, some with additional #2/0 lugs; each terminal will accommodate: (3) #14–#10 Cu/Al or (1) #14–#4 Cu/Al

Main and sub-feed lugs 125, 150, 225 A—two- and three-pole

Shunt trips

Surge protection:

Single-phase plug-on surge protector

Single-phase bottle type surge protector

Three-phase bottle type surge protector

Single-phase whole home surge protector

Universal rainproof conduit hubs

Group One: 3/4, 1, 1-1/4, 1-1/2, 2 inches (19.1, 25.4, 31.8, 38.1, 50.8 mm)

Group Two: 2, 2-1/2, 3 inches (50.8, 63.5, 76.2 mm)

Adapter plate

##### Bussing

Tin-plated aluminum as standard

Limited copper bus panels available

### Dimensions

Approximate Dimensions in Inches (mm)

#### Residential/Commercial/New York City Loadcenters, Unit Enclosures—Box Sizes

**Note:** Box sizes do not include covers/fronts.

#### Residential Loadcenters—NEMA Type 1 Indoor

Box Size	Height	Width	Depth
A1	15.00 (381.0)	11.25 (285.8)	3.75 (95.3)
B1	16.75 (425.5)	14.31 (363.5)	3.88 (98.4)
B2	18.75 (476.3)	14.31 (363.5)	3.88 (98.4)
C1	21.00 (533.4)	14.31 (363.5)	3.88 (98.4)
C2	23.00 (584.2)	14.31 (363.5)	3.88 (98.4)
C4	27.00 (685.8)	14.31 (363.5)	3.88 (98.4)
D1	29.13 (739.8)	14.31 (363.5)	3.88 (98.4)
G1	34.13 (866.8)	14.31 (363.5)	3.88 (98.4)
L1	39.00 (990.6)	14.31 (363.5)	3.88 (98.4)
L2	45.00 (1143.0)	14.31 (363.5)	3.88 (98.4)
L3	48.38 (1228.3)	14.31 (363.5)	3.88 (98.4)
2	8.63 (219.1)	5.00 (127.0)	3.50 (88.9)
3	9.44 (239.7)	4.50 (114.3)	3.00 (76.2)
4	13.00 (330.2)	11.00 (279.4)	3.56 (90.5)
5	9.44 (239.7)	4.50 (114.3)	3.00 (76.2)
6	12.00 (304.8)	6.88 (174.6)	4.50 (114.3)
7	13.00 (330.2)	11.00 (279.4)	3.56 (90.5)
9	14.50 (368.3)	6.50 (165.1)	3.50 (88.9)

#### Residential Loadcenters—NEMA Type 3R Outdoor

Box Size	Height	Width	Depth
B1R	16.75 (425.5)	14.31 (363.5)	5.19 (131.8)
B2R	18.75 (476.3)	14.31 (363.5)	5.19 (131.8)
C3R	25.00 (635.0)	14.31 (363.5)	5.19 (131.8)
D1R	29.13 (739.8)	14.31 (363.5)	5.19 (131.8)
G1R	34.13 (866.8)	14.31 (363.5)	5.19 (131.8)
L1R	39.00 (990.6)	14.31 (363.5)	5.19 (131.8)
L2R	45.00 (1143.0)	14.31 (363.5)	5.19 (131.8)
L3R	48.75 (1238.2)	14.31 (363.5)	5.19 (131.8)
2R	8.63 (219.1)	5.00 (127.0)	3.50 (88.9)
3R	9.44 (239.7)	4.50 (114.3)	3.00 (76.2)
4R	13.00 (330.2)	11.00 (279.4)	3.56 (90.5)
5R	9.44 (239.7)	4.50 (114.3)	3.00 (76.2)
6R	11.75 (298.5)	6.50 (165.1)	4.50 (114.3)
7R	13.00 (330.2)	11.00 (279.4)	3.56 (90.5)
8R	27.00 (685.8)	10.50 (266.7)	4.75 (120.7)
9R	14.25 (362.0)	6.50 (165.1)	4.00 (101.6)
C1R	21.00 (533.4)	14.31 (363.5)	5.19 (131.8)

#### Commercial Loadcenters—NEMA Type 1 Indoor

Box Size	Height	Width	Depth
19	44.00 (1117.6)	16.16 (410.4)	6.25 (158.8)
20	44.00 (1117.6)	16.16 (410.4)	6.25 (158.8)
22	54.00 (1371.6)	16.22 (412.0)	6.31 (160.3)
24	66.50 (1689.1)	16.22 (412.0)	6.31 (160.3)

#### Commercial Loadcenters—NEMA Type 3R Outdoor

Box Size	Height	Width	Depth
42	38.00 (965.2)	16.31 (414.3)	6.38 (161.9)
43	44.00 (1117.6)	16.31 (414.3)	6.38 (161.9)
46	54.00 (1371.6)	16.31 (414.3)	6.38 (161.9)
47	66.56 (1690.7)	16.31 (414.3)	6.38 (161.9)

#### New York City Loadcenters—NEMA Type 1 Indoor

Box Size	Height	Width	Depth
A	38.00 (965.2)	18.13 (460.4)	5.00 (127.0)
B	44.00 (1117.6)	18.13 (460.4)	5.00 (127.0)
C	66.50 (1689.1)	18.13 (460.4)	6.25 (158.8)

#### ECC Unit Enclosures—NEMA Type 1 Indoor

Height	Width	Depth
23.25 (590.6)	8.88 (225.4)	4.50 (114.3)

#### ECC Unit Enclosures—NEMA Type 3R Outdoor

Height	Width	Depth
23.68 (601.7)	9.31 (236.5)	5.44 (138.1)

# 1.2

## Loadcenters and Circuit Breakers

### Type BR Loadcenters and Circuit Breakers

1

Approximate Dimensions in Inches (mm)

#### Residential Loadcenter Knockouts

#### Knockouts for Box Sizes A1, B1, B2, C1, C2, C4, D1, G1, L1, L2, B1R, B2R, C1R, C3R, D1R, G1R, L1R, L2R

Code	Diameter				
A	0.50 (12.7)	0.75 (19.1)	—	—	—
B	0.50 (12.7)	—	—	—	—
C	0.50 (12.7)	1.25 (31.8)	1.50 (38.1)	2.00 (50.8)	2.50 (63.5)
D	1.25 (31.8)	1.25 (31.8)	2.00 (50.8)	2.50 (63.5)	—
E	0.50 (12.7)	0.75 (19.1)	1.00 (25.4)	—	—
F	0.50 (12.7)	0.75 (19.1)	1.00 (25.4)	1.50 (38.1)	2.00 (50.8)
G	1.25 (31.8)	1.50 (38.1)	2.00 (50.8)	—	—
H	0.50 (12.7)	0.75 (19.1)	1.00 (25.4)	1.25 (31.8)	1.50 (38.1)
I	1.00 (25.4)	1.25 (31.8)	1.50 (38.1)	2.00 (50.8)	2.50 (63.5)
J	1.00 (25.4)	1.25 (31.8)	1.50 (38.1)	—	—

#### Residential NEMA Type 1 Indoor and NEMA Type 3R Outdoor Enclosures

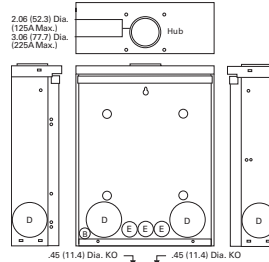

**Outdoor Boxes**  
B1R, B2R, C1R, C3R, D1R,  
G1R, L1R, L2R

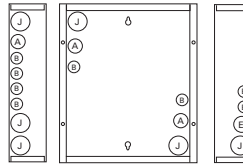
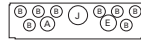

**Indoor Boxes**  
A1

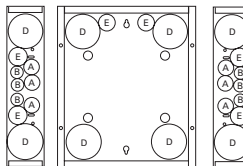
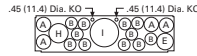

**Indoor Boxes**  
B1, B2

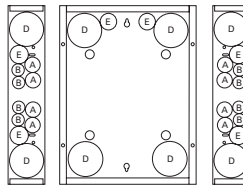
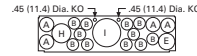

**Indoor Boxes**  
C1, C2, C4, D1, G1, L1, L2

Approximate Dimensions in Inches (mm)

### Knockouts for Box Sizes 3, 4, 5, 6, 7, 9, 2R, 3R, 4R, 5R, 6R, 7R, 8R, 9R

Code	Diameter			
A	0.50 (12.7)	—	—	—
B	0.50 (12.7)	0.75 (19.1)	—	—
C	0.50 (12.7)	0.75 (19.1)	1.00 (25.4)	—
D	0.50 (12.7)	0.75 (19.1)	1.00 (25.4)	1.25 (31.8)
E	0.75 (19.1)	1.00 (25.4)	1.25 (31.8)	—
F	0.75 (19.1)	1.00 (25.4)	1.25 (31.8)	1.50 (38.1)
G	1.00 (25.4)	1.25 (31.8)	1.50 (38.1)	—
H	1.00 (25.4)	1.25 (31.8)	1.50 (38.1)	2.00 (50.8)
I	1.25 (31.8)	1.50 (38.1)	2.00 (50.8)	—

### Residential NEMA Type 1 Indoor and NEMA Type 3R Outdoor Enclosures

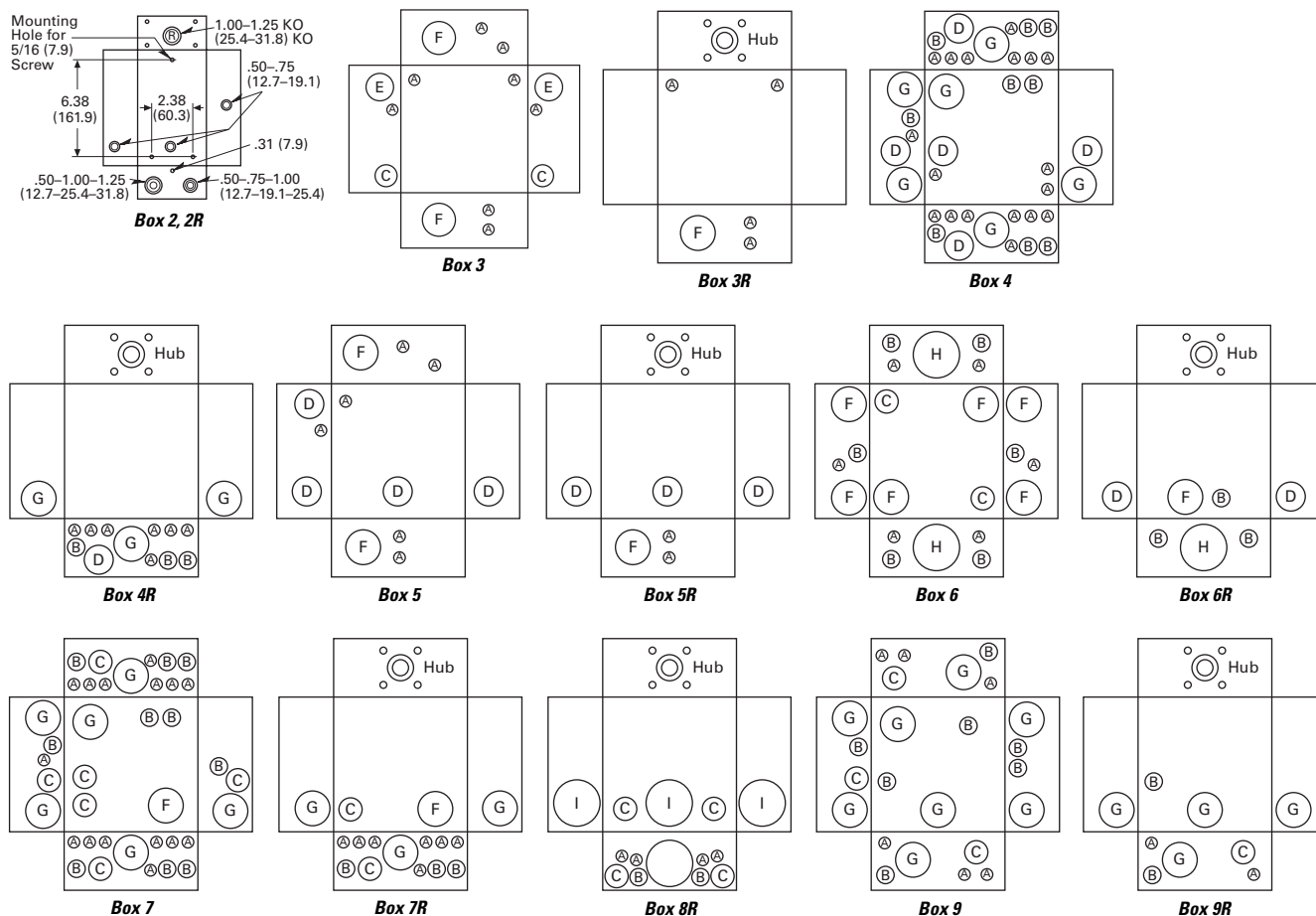



1

Approximate Dimensions in Inches (mm)

#### Commercial Loadcenter Knockouts

##### NEMA Type 1 Indoor Commercial Enclosures Knockouts for Box Sizes 19, 20, 22, 24

Code	Diameter			
A	0.50 (12.7)	—	—	—
B	0.50 (12.7)	0.75 (19.1)	—	—
C	0.75 (19.1)	1.00 (25.4)	1.50 (38.1)	—
D	1.50 (38.1)	2.00 (50.8)	2.50 (63.5)	3.00 (76.2)
E	2.00 (50.8)	2.50 (63.5)	3.00 (76.2)	—
F	2.50 (63.5)	3.00 (76.2)	3.50 (88.9)	—

##### NEMA Type 3R Outdoor Commercial Enclosures Knockouts for Box Sizes 42, 43, 46, 47

Code	Diameter			
A	0.50 (12.7)	—	—	—
B	0.50 (12.7)	0.75 (19.1)	—	—
C	0.75 (19.1)	1.00 (25.4)	1.25 (31.8)	—
D	1.50 (38.1)	2.00 (50.8)	2.50 (63.5)	—
E	2.00 (50.8)	2.50 (63.5)	3.00 (76.2)	—
F	2.50 (63.5)	3.00 (76.2)	3.50 (88.9)	—
G	1.25 (31.8)	1.50 (38.1)	2.00 (50.8)	2.50 (63.5)
H	3.25 (82.6) Sq.	—	—	—

#### Unit Enclosure Knockouts, Types ECB and ECC Knockouts

Code	Diameter			
<b>NEMA Type 1 Indoor (Flush and Surface Trims)</b>				
A	0.50 (12.7)	—	—	—
B	1.25 (31.8)	1.50 (38.1)	1.75 (44.5)	2.00 (50.8)
<b>NEMA Type 3R Outdoor</b>				
A	0.50 (12.7)	—	—	—
B	1.25 (31.8)	1.50 (38.1)	1.75 (44.5)	2.00 (50.8)

#### Indoor Commercial Enclosures

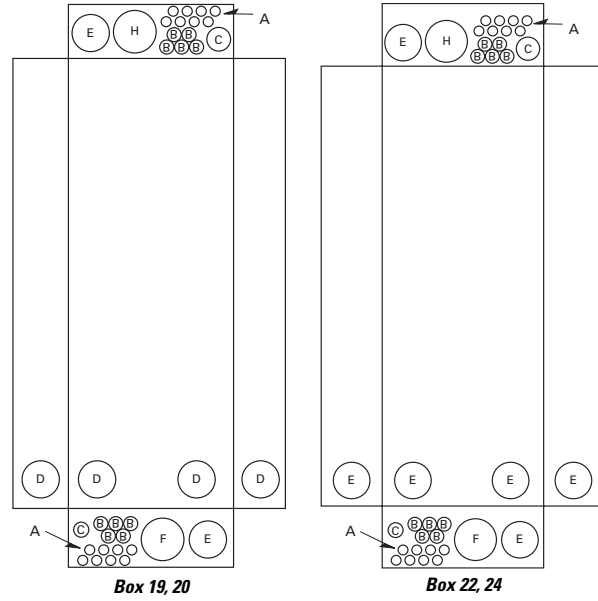

#### Outdoor Commercial Enclosures

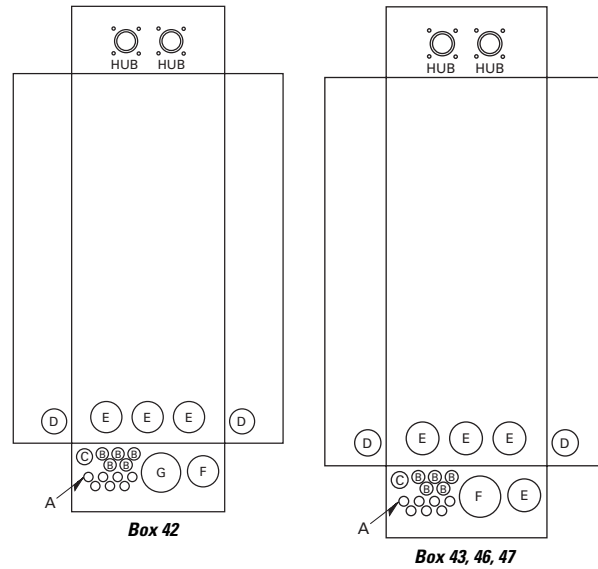

#### Unit Enclosure Knockouts

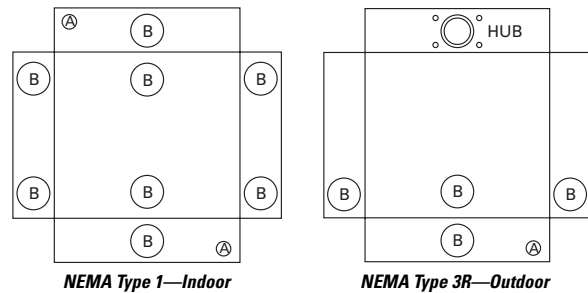

### BR Circuit Breakers



### Contents

<i>Description</i>	<i>Page</i>
Overview .....	<b>V1-T1-42</b>
BR Specialty Products	
BR Quick Connect Neutral Loadcenters .....	<b>V1-T1-57</b>
Spa Panels .....	<b>V1-T1-58</b>
Riser Panel .....	<b>V1-T1-59</b>
Type BR Renovation Loadcenter .....	<b>V1-T1-60</b>
BR Loadcenter Options and Accessories	
Type BR Retrofit Interior Kits .....	<b>V1-T1-61</b>
Type BR Mechanical Interlock Kits .....	<b>V1-T1-65</b>
BR Circuit Breakers	
Product Selection .....	<b>V1-T1-78</b>
Options and Accessories .....	<b>V1-T1-85</b>
Wiring Diagrams .....	<b>V1-T1-87</b>

## BR Circuit Breakers

### Product Description

#### **Plug-On Branch Feeder Type Arc Fault Circuit Breakers, Type BR—10 kAIC, 120 Vac and 120/240 Vac**

A branch feeder type arc fault circuit interrupter is a device intended to mitigate high current arcing faults in the complete circuit, including connected cords. High current arcing faults can occur from line to neutral or line to ground. These arcing faults are in parallel with the load and produce the most energy of all arcing faults.

The branch feeder type AFCI is required in the 1999 and 2002 National Electrical Code.

The Combination Type AFCI is required in the 2005, 2008, and 2011 National Electrical Code.

#### **Plug-On Combination Type Arc Fault Circuit Breakers, Type BR—10 kAIC, 120 Vac and 120/240 Vac**

A combination type arc fault circuit interrupter is a device that includes all of the protection offered by the branch feeder AFCI (mitigation of high current arcing faults in the complete circuit, including connected cords). In addition it provides direct detection of persistent low current arcing faults down to 5 amps with associated mitigation of fire hazards in the cords connected to the outlets. High current arcing faults can occur from line to neutral or line to ground. These arcing faults are in parallel with the load and produce the most energy of all arcing faults. The current level of low current arcing faults is limited by the load.

#### **Plug-On Ground Fault Circuit Breakers, Type GFTCB and GFEP—10/22 kAIC, 120 Vac and 120/240 Vac**

##### **Ground Fault Application Notes**

Single-pole GFTCBs are designed for use in two-wire, 120 Vac circuits. See **Page V1-T1-87** for a typical wiring configuration.

Two-pole GFTCBs are designed for use in three-wire, 120/240 Vac circuits, 120 Vac multiwire circuits employing common, neutral and two-wire, 240 Vac circuits obtained from a 120/240 Vac source.

**Page V1-T1-87** shows typical wiring configurations for a 120/240 Vac multiwire circuits, and a 240 Vac, two-wire circuit. Note the "panel neutral" conductor connects to the neutral bar, even though the neutral is not included in the load circuit. This connection is necessary to supply a 120 Vac power source to the ground fault sensing circuit.

The figures are shown with a 120/240 Vac, single-phase, three-wire power source, but are also applicable to a 120/208 Vac, three-phase, four-wire power supply. For all figures, the electrical operation of the GFTCB is not affected by the equipment ground.

#### **Non-CTL Plug-On Replacement—Circuit Breakers, Type BRD—10 kAIC, 120/240 Vac**

##### **Non-CTL 10 kAIC for Replacement Purposes Only**

For replacement in enclosures manufactured prior to 1968 with unnotched stabs. Circuit breakers do not have rejection tab.

# 1.2

## Loadcenters and Circuit Breakers

### Type BR Loadcenters and Circuit Breakers

1

#### Product Selection

Plug-On Circuit Breakers, Types BR—10/22/42 kAIC, 120 Vac, 120/240 Vac and 240 Vac

BR120



BR215



BR320



BRH2100



BRX2125



#### Type BR Breakers, 1-Inch (25.4 mm) per Pole 120/240, 10, 22 and 42 kAIC

Ampere Rating	Wire Size Range Cu/Al 60 °C or 75 °C	Single-Pole 120/240 Vac Requires One 1-Inch (25.4 mm) Space 10 per Shelf Carton		Two-Pole 120/240 Vac Common Trip Requires Two 1-Inch (25.4 mm) Spaces 5 per Shelf Carton		42 kAIC Catalog Number	65 kAIC Catalog Number
		10 kAIC Catalog Number	22 kAIC Catalog Number	10 kAIC Catalog Number	22 kAIC Catalog Number		
10	#14–4	BR110	—	BR210	—	—	—
15	#14–4	BR115 <sup>①②</sup>	BRH115	BR215 <sup>③</sup>	BRH215	—	—
20	#14–4	BR120 <sup>①②</sup>	BRH120	BR220 <sup>③</sup>	BRH220	—	—
25	#14–4	BR125	BRH125	BR225 <sup>③</sup>	BRH225	—	—
30	#14–4	BR130	BRH130	BR230 <sup>③</sup>	BRH230	—	—
35	#14–4	BR135	BRH135	BR235 <sup>③</sup>	BRH235	—	—
40	#14–4	BR140	BRH140	BR240 <sup>③</sup>	BRH240 <sup>③</sup>	—	—
45	#14–4	—	BRH145	BR245 <sup>③</sup>	BRH245	—	—
50	#14–4	BR150	BRH150	BR250 <sup>③</sup>	BRH250 <sup>③</sup>	—	—
55	#14–3	BR150	BRH155	BR255	BRH255	—	—
60	#8–1/0	BR160	BRH160	BR260	BRH260	BRHH260	BRX260
70	#8–1/0	BR170	BRH170	BR270	BRH270	BRHH270	BRX270
80	#8–1/0	—	—	BR280	BRH280	BRHH280	BRX280
90	#8–1/0	—	—	BR290	BRH290	BRHH290	BRX290
100	#8–1/0	—	—	BR2100	BRH2100	BRHH2100	BRX2100
110	#8–1/0	—	—	BR2110	BRH2110	BRHH2110	BRX2110
125	#4–2/0	—	—	BR2125	BRH2125	BRHH2125	BRX2125
150	#4–2/0	—	—	BR2150 <sup>④</sup>	—	—	—



#### Notes

- ① One pole, 1-inch (25.4 mm) per pole circuit breakers are available with high magnetic setting for switching large tungsten lamp loads. Add suffix H to catalog number.
- ② Switching duty rated.
- ③ On the black handle breaker, add suffix “B” to the catalog number to obtain a tapped molded opening for proper use with hold-down kits.
- ④ For use as a branch circuit breaker in 400 and 600 ampere panels only.

All Type BR single-, two- and three-pole circuit breakers carry listing for HACR application. For circuit breakers with a shunt trip, add ST suffix.

### BR Breakers

### Type BR Breakers, 1-Inch (25.4 mm) per Pole 240 Vac, 10, 22 and 42 kAIC



Three-Pole 240 Vac  
Common Trip Requires Three  
1-Inch (25.4 mm) Spaces  
5 per Shelf Carton



Ampere Rating	Wire Size Range Cu/Al 60 °C or 75 °C	10 kAIC Catalog Number	22 kAIC Catalog Number
10	#14–4	BR310	—
15	#14–4	BR315 ①	BRH315
20	#14–4	BR320 ①	BRH320
25	#14–4	BR325	BRH325
30	#14–4	BR330	BRH330
35	#14–4	BR335	BRH335
40	#14–4	BR340	BRH340
45	#14–4	BR345	BRH345
50	#14–4	BR350	BRH350
55	#14–3	BR355	BRH355
60	#4–1/0	BR360	BRH360
70	#4–1/0	BR370	BRH370
80	#4–1/0	BR380	BRH380
90	#4–1/0	BR390	BRH390
100	#4–1/0	BR3100	BRH3100

### Plug-On, Dual Purpose Arc Fault / Ground Fault Circuit Breakers, Type BR—10 kAIC, 120 Vac

#### BRLAFGF115



### Type BR, 1-Inch (25.4 mm) wide Dual Purpose AF/GF Circuit Breakers ②③

Poles	Ampere Rating	Configuration	Catalog Number
Single-pole 10 kAIC	15	Combination AFGI / GFCI	BRLAFGF115 ④
			BRAFGF115 ⑤
	20		BRLAFGF120 ④
			BRAFGF120 ⑤
Single-pole 22 kAIC	15	Combination AFGI / GFCI	BRHAFGF115 ⑤
	20		BRHAFGF120 ⑤

### Plug-On Combination Type Arc Fault Circuit Breakers, Type BR—10 kAIC, 120 Vac and 120/240 Vac

#### BRCAF115



### Type BR, 1-Inch (25.4 mm) wide Combination Type AFCI Circuit Breakers

Poles	Ampere Rating	Configuration	Catalog Number
Single-pole 10 kAIC	15	AFCI	BRCAF115 ⑥
	20	AFCI	BRCAF120 ⑥
Single-pole 22 kAIC	15	AFCI	BRHCAF115 ⑥
	20	AFCI	BRHCAF120 ⑥
Two-pole 10 kAIC	15	AFCI	BRL215CAF
	20	AFCI	BRL220CAF

#### Notes

- ① One pole, 1-inch (25.4 mm) per pole circuit breakers are available with high magnetic setting for switching large tungsten lamp loads. Add suffix H to catalog number.
- ② Breaker qualifies as combination arc fault, per UL 1699.
- ③ Breaker qualifies as personnel protection ground fault, (5 mA) per UL 943.
- ④ These catalog numbers will be obsoleted in Q3, 2018 and replaced with BRAFGF short body breakers.
- ⑤ Short body replacing BRLAFGF breakers.
- ⑥ Clamshell packaging available with CS modification code on the end of catalog number.

All Type BR single-, two- and three-pole circuit breakers carry listing for HACR application. For circuit breakers with a shunt trip, add ST suffix. See **Volume 4** for bolt-on AF/GF breakers; QB1015AFGF, QB1020AFGF, QBH1015AFGF and QBH1020AFGF.

# 1.2

## Loadcenters and Circuit Breakers

### Type BR Loadcenters and Circuit Breakers

1

#### Plug-On Ground Fault Circuit Breakers, Type GFTCB and GFEP—10/22 kAIC, 120 Vac and 120/240 Vac

Type GFTCB Single-Pole



Type GFTCB Two-Pole



#### Type GFTCB Ground Fault Circuit Breakers—5 Milliamperere—1-Inch (25.4 mm) per Pole 120 Vac or 120/240 Vac, 10 kAIC

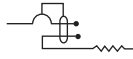

Single-Pole 120 Vac  
Requires One  
1-Inch (25.4 mm) Space  
1 per Shelf Carton  
Catalog Number ①



Two-Pole 120/240 Vac  
Common Trip Requires Two  
1-Inch (25.4 mm) Spaces  
1 per Shelf Carton  
Catalog Number

Ampere Rating	Wire Size Range Cu/Al 60 °C or 75 °C	Single-Pole 120 Vac Requires One 1-Inch (25.4 mm) Space 1 per Shelf Carton Catalog Number ①	Two-Pole 120/240 Vac Common Trip Requires Two 1-Inch (25.4 mm) Spaces 1 per Shelf Carton Catalog Number
15	#14–4	GFTCB115	GFTCB215
20	#14–4	GFTCB120	GFTCB220
25	#14–4	GFTCB125	GFTCB225
30	#14–4	GFTCB130	GFTCB230
40	#14–4	GFTCB140	GFTCB240
50	#14–4	—	GFTCB250 ②
60	#14–6	—	GFTCB260

#### Type GFTCBH Ground Fault Breakers—5 Milliamperere—1-Inch (25.4 mm) per Pole 120 Vac or 120/240 Vac, 22 kAIC

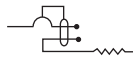

Single-Pole 120 Vac  
Requires One  
1-Inch (25.4 mm) Space  
1 per Shelf Carton  
Catalog Number



Two-Pole 120/240 Vac  
Common Trip Requires Two  
1-Inch (25.4 mm) Spaces  
1 per Shelf Carton  
Catalog Number

Ampere Rating	Wire Size Range Cu/Al 60 °C or 75 °C	Single-Pole 120 Vac Requires One 1-Inch (25.4 mm) Space 1 per Shelf Carton Catalog Number	Two-Pole 120/240 Vac Common Trip Requires Two 1-Inch (25.4 mm) Spaces 1 per Shelf Carton Catalog Number
15	#14–4	GFTCBH115	GFTCBH215
20	#14–4	GFTCBH120	GFTCBH220
25	#14–4	GFTCBH125	GFTCBH225
30	#14–4	GFTCBH130	GFTCBH230

#### Type GFEP Ground Fault Equipment Protectors—30 Milliamperere—1-Inch (25.4 mm) per Pole 120 Vac or 120/240 Vac, 10 kAIC

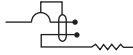

Single-Pole 120 Vac  
Requires One  
1-Inch (25.4 mm) Space  
1 per Shelf Carton  
Catalog Number



Two-Pole 120/240 Vac  
Common Trip Requires Two  
1-Inch (25.4 mm) Space  
1 per Shelf Carton  
Catalog Number

Ampere Rating	Wire Size Range Cu/Al 60 °C or 75 °C	Single-Pole 120 Vac Requires One 1-Inch (25.4 mm) Space 1 per Shelf Carton Catalog Number	Two-Pole 120/240 Vac Common Trip Requires Two 1-Inch (25.4 mm) Space 1 per Shelf Carton Catalog Number
15	#14–4	GFEP115	GFEP215
20	#14–4	GFEP120	GFEP220
25	#14–4	GFEP125	GFEP225
30	#14–4	GFEP130	GFEP230
40	#14–4	—	GFEP240
50	#14–4	—	GFEP250 ②

#### Notes

- ① Available with bell alarm or auxiliary switch. See circuit breaker accessories on [Page V1-T1-85](#).
- ② For use with copper wire only.

### CTL Plug-On Circuit Breakers, Type BD Duplex, BQ and BQC Quadplex—10 kAIC, 120/240 Vac

BD2020

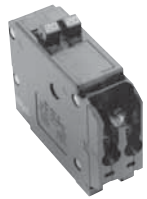

#### Class CTL, 1-Inch (25.4 mm) per Pole 10 kAIC—All Circuit Breakers Have Rejection Tab Feature

**Type BD Duplex (UL Type BRD)**

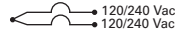

**Single-Pole ①**  
Requires One 1-Inch (25.4 mm) Space  
10 per Shelf Carton

**Type BQ Quadplex Independent Trip (UL Type BRD)**

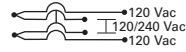

**Two-Pole ② and Single-Pole ①**  
Requires Two 1-Inch (25.4 mm) Spaces  
5 per Shelf Carton

**Type BQ Quadplex Independent Trip (UL Type BRD)**

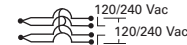

**Two-Pole**  
Requires Two 1-Inch (25.4 mm) Spaces  
5 per Shelf Carton

BQ2302115

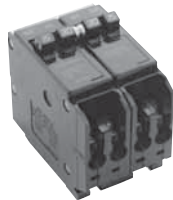

BQ230230

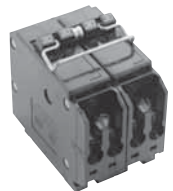

Ampere Rating	Catalog Number	Wire Size Range Cu/Al 65 °C or 75 °C	Ampere Rating			Catalog Number	Ampere Rating		
			Outer Left Single-Pole	Center Two-Pole Independent Trip	Outer Right Single-Pole		Outer Two-Pole Independent Trip	Center Two-Pole Independent Trip	Catalog Number
10–10	BD1010	#14–4	15	20	15	BQ2202115	15	15	BQ215215
15–15	BD1515	#14–4	20	20	20	BQ2202120	15	20	BQ215220
15–20	BD1520	#14–4	15	30	15	BQ2302115	15	30	BQ215230
15–30	BD1530	#14–4	20	30	20	BQ2302120	15	40	BQ215240
20–15	BD2015	#14–4	15	40	15	BQ2402115	15	50	BQ215250
20–20	BD2020	#14–4	20	40	20	BQ2402120	20	20	BQ220220
20–30	BD2030	#14–4	15	50	15	BQ2502115	20	30	BQ220230
25–25	BD2525	#14–4	20	50	20	BQ2502120	20	40	BQ220240
30–15	BD3015	#14–4	—	—	—	—	20	50	BQ220250
30–20	BD3020	#14–4	—	—	—	—	25	25	BQ225225
30–30	BD3030	#14–4	—	—	—	—	30	30	BQ230230
30–40	BD3040	#14–4	—	—	—	—	30	40	BQ230240
30–50	BD3050	#14–4	—	—	—	—	30	50	BQ230250
50–30	BD5030	#14–4	—	—	—	—	40	40	BQ240240
50–50	BD5050	#14–4	—	—	—	—	40	50	BQ240250
—	—	—	—	—	—	—	50	50	BQ250250

**Notes**

- ① All 15 and 20 A single poles are switch-duty rated.
- ② All Type BD duplex and BQ quadplex circuit breakers carry listing for HACR applications.
- ③ Available with bell alarm or auxiliary switch. See circuit breaker accessories on **Page V1-T1-85**.
- ④ For use with copper wire only.

# 1.2

## Loadcenters and Circuit Breakers

### Type BR Loadcenters and Circuit Breakers

1

#### Non-CTL Plug-On Replacement—Circuit Breakers, Type BRD—10 kAIC, 120/240 Vac

BR2020



#### Class Non-CTL, 1-Inch (25.4 mm) per Pole 10 kAIC—Breakers Do Not Have Rejection Tab Feature

##### Type BR Duplex

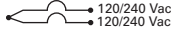

Single-Pole Requires One 1-Inch (25.4 mm) Space 10 per Shelf Carton

##### Type Brand BRD Quadplex Independent Trip

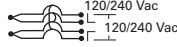

Two-Pole Requires Two 1-Inch (25.4 mm) Spaces 5 per Shelf Carton

##### Type BRD Quadplex Common Trip Center and Outer Poles

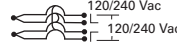

Two-Pole Requires Two 1-Inch (25.4 mm) Spaces 5 per Shelf Carton

Ampere Rating	120 Vac		120/240 Vac		120/240 Vac		120/240 Vac	
	Catalog Number	Wire Size Range Cu/Al 65 °C or 75 °C	Outer Two-Pole Independent Trip	Center Two-Pole Independent Trip	Catalog Number	Outer Two-Pole Common Trip	Center Two-Pole Common Trip	Catalog Number
15–15	BR1515	#14–4	15	15	BR415	15	15	BRDC215215
15–20	BR1520	#14–4	20	20	BR420	30	30	BRDC230230
20–15	BR2015	#14–4	30	30	BR430	30	40	BRDC230240
20–20	BR2020	#14–4	20	30	BRD220230	30	50	BRDC230250
30–30	BR3030	#14–4	30	40	BRD230240	—	—	—
30–50	BR3050	#14–4	30	50	BRD230250	—	—	—

#### CTL and Non-CTL Breakers

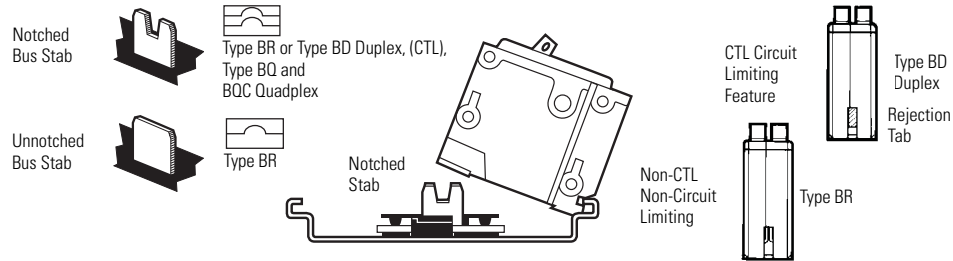

### Common Trip Quadplex Breakers

BQC2302115

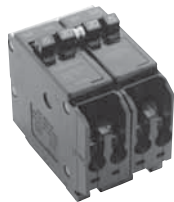

#### Class CTL, 1-Inch (25.4 mm) per Pole 10 kAIC—All Circuit Breakers Have Rejection Tab Feature

Type BQC Quadplex Common Trip Center Poles (UL Type BRD)

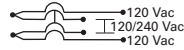

Two-Pole ① and Single-Pole ②  
Requires Two 1-Inch (25.4 mm) Spaces  
5 per Shelf Carton

120 Vac      120/240 Vac      120 Vac

Type BQC Quadplex Common Trip Center and Outer Poles (UL Type BRD)



Two-Pole ①  
Requires Two 1-Inch (25.4 mm) Spaces  
5 per Shelf Carton

120/240 Vac

BQC2302115

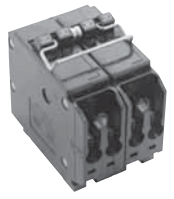

Ampere Rating			Catalog Number	Wire Size Range Cu/Al 65 °C or 75 °C	Ampere Rating		
Outer Left Single-Pole	Center Two-Pole Common Trip	Outer Right Single-Pole			Outer Two-Pole Common Trip	Center Two-Pole Common Trip	Catalog Number
15	20	15	BQC2202115	#14–4	15	15	BQC215215
15	25	15	BQC2252115	#14–4	15	20	BQC215220
15	30	15	BQC2302115	#14–4	15	30	BQC215230
15	40	15	BQC2402115	#14–4	20	15	BQC220215
15	50	15	BQC2502115	#14–4	20	20	BQC220220
—	—	—	—	#14–4	20	30	BQC220230
—	—	—	—	#14–4	20	40	BQC220240
—	—	—	—	#14–4	20	50	BQC220250
20	15	20	BQC2152120	#14–4	25	25	BQC225225
20	20	20	BQC2202120	#14–4	25	30	BQC225230
20	25	20	BQC2252120	#14–4	30	15	BQC230215
20	30	20	BQC2302120	#14–4	30	30	BQC230230
20	40	20	BQC2402120	#14–4	30	40	BQC230240
20	50	20	BQC2502120	#14–4	30	50	BQC230250
30	50	20	BQC2502030	#14–4	40	30	BQC240230
—	—	—	—	#14–4	40	40	BQC240240
—	—	—	—	#14–4	40	50	BQC240250
—	—	—	—	#14–4	50	20	BQC250220
—	—	—	—	#14–4	50	50	BQC250250

**Notes**

- ① All Type BQC quadplex circuit breakers carry listing for HACR applications.
- ② All 15 and 20 ampere single poles are switch-duty rated.



# 1.2

## Loadcenters and Circuit Breakers

### Type BR Loadcenters and Circuit Breakers

1

#### Plug-On Circuit Breakers, Types BJ and BJH—10/22 kAIC, 120/240 Vac and 240 Vac

For Use in Single-Phase and Three-Phase Loadcenters—150 Amperes and Above

##### Type BJ

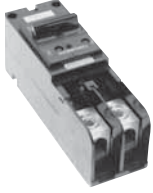

#### Types BJ and BJH Breakers, 1-Inch (25.4 mm) per Pole, 120/240 or 240 Vac, 10, 22 kAIC



**Two-Pole 120/240 Vac**  
Common Trip Requires Four  
1-Inch (25.4 mm) Spaces <sup>①</sup>  
10 per Shelf Carton



**Three-Pole 240 Vac**  
Common Trip Requires Six  
1-Inch (25.4 mm) Spaces <sup>②</sup>  
5 per Shelf Carton

Ampere Rating	10 kAIC		Wire Size Range Cu/Al 60 °C or 75 °C	22 kAIC	
	Catalog Number	Catalog Number		Catalog Number	Catalog Number
125	BJ2125	BJH2125	#2–300 kcmil	BJ3125	BJH3125
150	BJ2150	BJH2150	#2–300 kcmil	BJ3150	BJH3150
175	BJ2175	BJH2175	#2–300 kcmil	BJ3175	BJH3175
200	BJ2200	BJH2200	#2–300 kcmil	BJ3200	BJH3200
225	BJ2225	BJH2225	#2–300 kcmil	BJ3225	BJH3225

#### Plug-On Special Application Circuit Breakers—10 kAIC, 120 Vac, 120/240 Vac and 240 Vac

##### BRWH215

Water Heater Breaker



##### BRSN220

Switching Neutral Breaker



#### Special Application Circuit Breakers, 1-Inch (25.4 mm) per Pole

##### Water Heater Breakers



**Two-Pole 120/240 Vac**  
Common Trip Requires Two  
1-Inch (25.4 mm) Spaces

With Isolated Line Terminals  
for Separately Metered  
Water Heaters

5 per Shelf Carton

10 kAIC

Ampere Rating    Catalog Number

##### Switching Neutral Breakers



**Two-Pole 120 Vac**  
Common Trip Requires Two  
1-Inch (25.4 mm) Spaces

With Switching Neutral Pole  
for Gasoline Pump Applications

5 per Shelf Carton

10 kAIC

Ampere Rating    Catalog Number

##### 240 V Breakers



**Two-Pole 240 Vac**  
Common Trip Requires Two  
1-Inch (25.4 mm) Spaces

Where Voltage to  
Ground is 240 Vac

5 per Shelf Carton

10 kAIC

Ampere Rating    Catalog Number

##### Non-Automatic Molded Case Switches



**Two-Pole 240 Vac**  
Requires Two  
1-Inch (25.4 mm) Spaces

For Use as Disconnect Contains No  
Magnetic or Thermal Trip Properties

5 per Shelf Carton

5 kAIC

Ampere Rating    Catalog Number

15	BRWH215	15	BRSN215	#14–4	10	BR210H	—	—
20	BRWH220	20	BRSN220	#14–4	15	BR215H	—	—
30	BRWH230	25	BRSN225	#14–4	20	BR220H	—	—
—	—	30	BRSN230	#14–4	25	BR225H	—	—
—	—	—	—	#14–4	30	BR230H	—	—
—	—	—	—	#14–4	35	BR235H	—	—
—	—	—	—	#14–4	40	BR240H	—	—
—	—	—	—	#14–4	45	BR245H	—	—
—	—	—	—	#14–4	50	BR250H	50	BR250NA
—	—	—	—	#14–4	55	BR255H	—	—
—	—	—	—	#4–1/0	60	BR260H	60	BR260NA
—	—	—	—	#4–1/0	70	BR270H	—	—
—	—	—	—	#4–1/0	80	BR280H	—	—
—	—	—	—	#4–1/0	90	BR290H	—	—
—	—	—	—	#4–1/0	100	BR2100H	100	BR2100NA

##### Notes

<sup>①</sup> Breaker uses two 1-inch (25.4 mm) pole spaces on left side and two 1-inch (25.4 mm) pole spaces on right side of loadcenter.

<sup>②</sup> Breaker uses three 1-inch (25.4 mm) pole spaces on left side and three 1-inch (25.4 mm) pole spaces on right side of loadcenter.

If BJ or BJH breakers are used as a main or a back feed device, a hold-down kit is required. See **Page V1-T1-85**.

### Options and Accessories

THS1

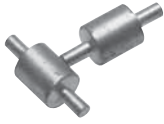

BHLW2



BRQLW



MCBPL (Installed)



BHLW



BRLW2



### Field Installation Kits and Parts

Description	Ordering Quantity <sup>①</sup>	Catalog Number
<b>New Products</b>		
Padlockable device for locking the handle of BR long body AF/GF breaker into the ON or OFF position		<b>BRLAFGFLOFF</b>
Padlockable device for locking the handle of BR short body BRCAF, BRAFGF, QBCAF, QBAFGF breakers into the ON or OFF position		<b>BRCAFLOFF</b>
<b>Handle Ties <sup>②</sup></b>		
Handle tie bar for physically joining the handles of two adjacent single-pole Type BR circuit breakers (metal cylinder pin type)	10	<b>BHT</b>
Handle tie bar for joining two independent outside poles of Types BQ and BQC Quadplex and outside poles of two Type BD duplex circuit breakers	10	<b>THOW</b>
Handle tie bar for joining two adjacent outside poles of Types BQ and BQC Quadplex and outside poles of two Type BD duplex circuit breakers	10	<b>THS1</b>
<b>Handle Lockoffs <sup>③④</sup></b>		
Padlockable device for locking the handle of single-, two- or three-pole Type BR Circuit Breakers and single-pole of a Type BD Duplex or one independent outside pole of a Type BQ or BQC Quadplex circuit breakers (escutcheon mounted) <sup>⑤</sup>	10	<b>BRLW</b>
Padlockable device for locking the handle of a single-pole Type BR circuit breaker (handle mounted) <sup>⑥</sup>	10	<b>BRLW1</b>
Padlockable device for locking the handle of a two- and three-pole Type BR circuit breaker (handle mounted) <sup>⑥</sup>	10	<b>BRLW2</b>
Padlockable device for locking the handle of a single-pole Type BD Duplex, BQ or BQC Quadplex breaker (handle mounted) <sup>⑥</sup>	10	<b>BRDL1</b>
Padlockable device for locking the handle of the two center poles and the two outer poles of a two-pole Types BQ and BQC quadplex circuit breakers (escutcheon mounted) <sup>⑤</sup>	10	<b>BRQLW</b>
Padlockable device for locking the handle of main circuit breaker Types CC and CHH into the ON or OFF position (screw mounted) <sup>⑦</sup>	1	<b>CCPL</b>
Padlockable device for locking the handle of main breaker Types BW and CSR into the ON or OFF position (escutcheon mounted) <sup>⑤</sup>	1	<b>MCBPL</b>
Device used to secure handle in ON or OFF position for single-, two- or three-pole Type BR circuit breakers and single-pole of Type BD duplex and one independent outside pole of Type BQ or BQC Quadplex circuit breakers (escutcheon mounted) <sup>⑤</sup>	10	<b>BHLW</b>
Device used to secure handle in ON or OFF position for single-pole Type BR circuit breakers (handle mounted) <sup>⑥</sup>	10	<b>BHLW1</b>
Device used to secure handle in ON or OFF position for two- and three-pole Type BR circuit breakers (handle mounted) <sup>⑥</sup>	10	<b>BHLW2</b>
Device used to secure handle in ON or OFF position for single-pole Type GFTCB ground fault circuit breakers (handle mounted) <sup>⑥</sup>	10	<b>BHGW</b>
Device used to secure handle in ON or OFF position for one independent outside pole of Types BQ and BQC Quadplex or single-pole Type BD duplex circuit breakers (handle mounted) <sup>⑥</sup>	10	<b>HLW1</b>

### Notes

- ① Must be purchased in multiples of ordering quantities indicated.
- ② Handle ties: typically used to join two similar independent single-pole breakers to form a two-pole noncommon trip breaker.
- ③ Handle lockoffs: devices that use a padlock to lock the circuit breaker's handle in the ON or OFF position.
- ④ See table on **Page V1-T1-86** for handle position changeability chart.
- ⑤ Escutcheon mounted: device mounted semipermanently to the face of the circuit breaker and secured by the loadcenter deadfront.
- ⑥ Handle mounted: device mounted directly to the handle by the use of a set screw.
- ⑦ Screw mounted: device permanently mounted to the face of the circuit breaker by the use of a non-removable screw.
- ⑧ Hold-down kits: devices used to secure the circuit breaker to the loadcenter for back-feed main application. See NEC Article 408.36(D). Add "B" suffix to two-pole breaker for tapped hole for hold-down kit (ex. BR230B) for BR breakers below 60 A.

1

**BREQS125**



**BRHDK125**



**BRML**



#### Field Installation Kits and Parts, continued

Description	Ordering Quantity <sup>①</sup>	Catalog Number
<b>Hold-Down Kits <sup>②</sup></b>		
Hold-down retainer kit for three-pole Type BR circuit breakers in S3100 and 3100R loadcenters only	1	<b>BRHDB</b>
Hold-down screw kit for two- and three-pole Type BR circuit breakers in single-phase MLO loadcenters through 100–125 A	1	<b>BREQS125</b>
Hold-down screw kit for two- and three-pole Type BR circuit breakers in MLO loadcenters 150–225 A	1	<b>BRHDK125</b>
Hold-down screw kit for two-pole Types BJ and BJH circuit breakers in MLO loadcenters 125–225 A	1	<b>BJHDS</b>
Hold-down screw kit for three-pole Types BJ and BJH circuit breakers in MLO loadcenters 125–225 A	1	<b>BJHDS3P</b>
<b>Main Breaker Lug Kits</b>		
Types CC and CHH main breaker lug kit (2) 300 kcmil	1	<b>CCL300</b>
Types BW/CSR main breaker lug kit (2) 300 kcmil	1	<b>MCBL300</b>
<b>Mechanical Interlocks</b>		
Types BR for two-, three- and four-pole breakers	10	<b>BRML</b>
<b>Padlock Brackets</b>		
BR padlock mounting bracket	10	<b>BRPLOFF</b>
BR three-pole lock-off bracket	10	<b>BRPLOFF3P</b>
BJ two-pole lock-off bracket	10	<b>BJL2P</b>
BJ three-pole lock-off bracket	10	<b>BJL3P</b>

#### Shunt Trips, Auxiliary and Alarm Contacts

Description	Catalog Number <sup>②</sup> Suffix Adder
<b>Shunt Trip for Types BW/CSR</b>	
12 Volts	<b>SR12</b>
24 Volts	<b>SR24</b>
120 Volts	<b>SR01</b>
<b>Shunt Trip for Types BR</b>	
120 Volts	<b>ST</b>
<b>Auxiliary Contact for Types BW/CSR</b>	
1NO and 1NC	<b>AL1</b>
2NO and 2NC	<b>AL2</b>
<b>Alarm Contacts for Types BW/CSR</b>	
Types BW/CSR	<b>CR1</b>
<b>Alarm Contacts for Type GFTCB (Single-Pole)</b>	
Alarm contact for GFTCB (single-pole)	<b>W1</b>
1NO and 1NC	<b>W2</b>

#### Handle Position Changeability Chart

To Change Handle Position from ON to OFF, or OFF to ON  
You Must...

Handle Lockoff and Lockdog Types	Remove Padlock	Remove Device	Remove Loadcenter Deadfront
Lockoff escutcheon mounted	Remove	—	—
Lockoff handle mounted	Remove	Remove	—
Lockoff screw mounted	Remove	—	—
Lockdog escutcheon mounted	N/A	Remove	Remove
Lockdog handle mounted	N/A	Remove	—

#### Notes

- ① Must be purchased in multiples of ordering quantities indicated.
- ② Add suffix indicated to end of breaker catalog number.

### Wiring Diagrams

**Single-Pole 120 V Load Application Sourced by 120/240 Vac**

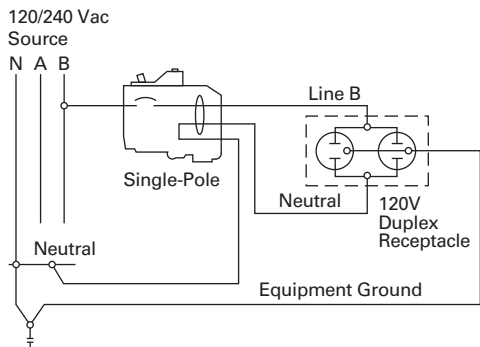

**Two-Pole Shared Neutral with Duplex Receptacle Application**

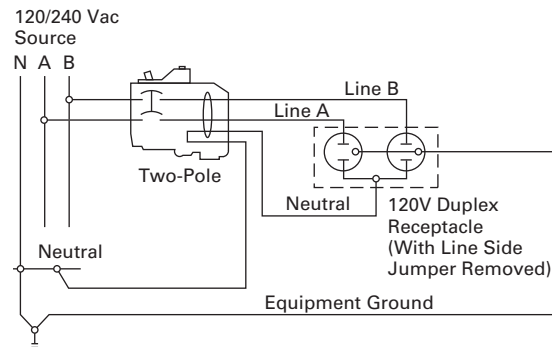

**Two-Pole Shared Neutral with Multi-Duplex Receptacle Application**

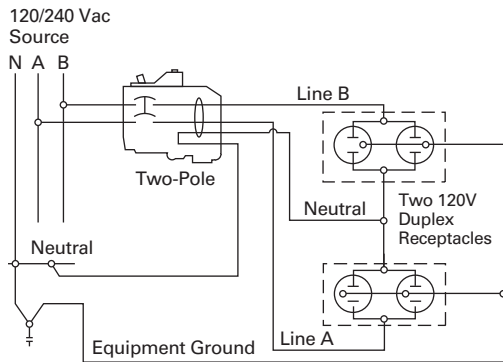

**Single-Pole 120 V Load Application Sourced by 120/240 Vac**

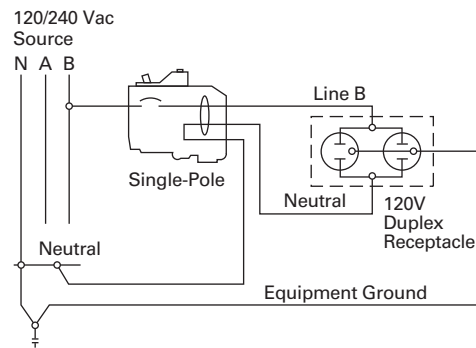

**Two-Pole 240 V Load Application Sourced by 120/240 Vac**

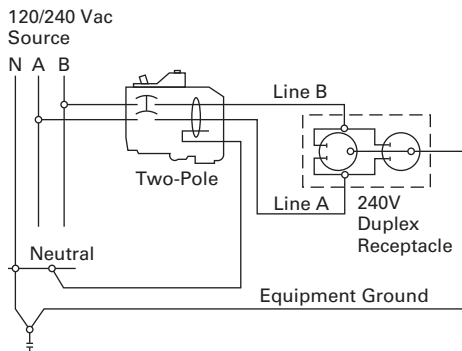

**Single-Pole 120 V Duplex Receptacle Application**

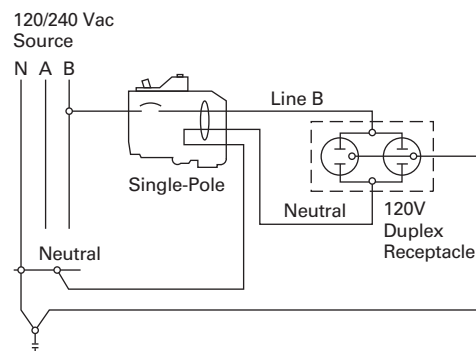

# 1.2

## Loadcenters and Circuit Breakers

### Type BR Loadcenters and Circuit Breakers

#### 1 Two-Pole 120 V Multi-Duplex Receptacle Application

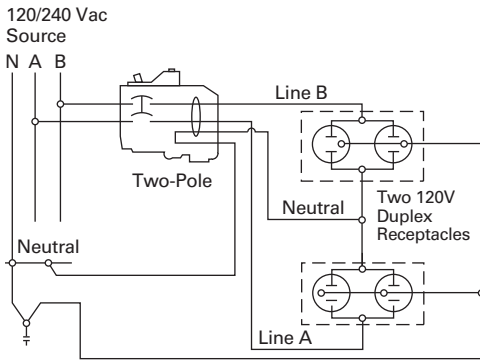

#### Two-Pole 120 V Duplex Receptacle Application

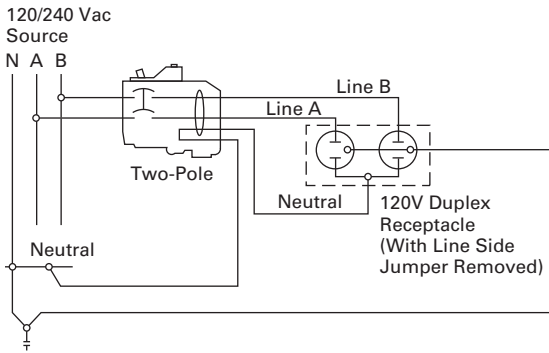

#### Two-Pole 240 V Duplex Receptacle Application

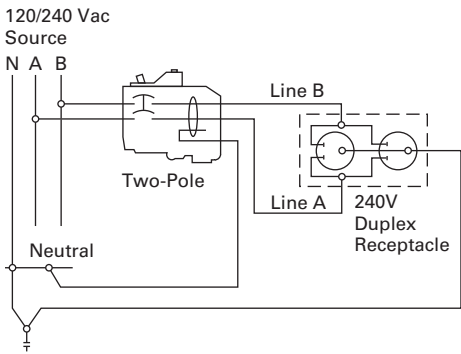

### OEM Loadcenters



### Contents

#### Description

	<i>Page</i>
Standards and Certifications . . . . .	<b>V1-T1-90</b>
Product Selection . . . . .	<b>V1-T1-90</b>

### Product Description

As a leader in the electrical distribution equipment business, Eaton has a unique product offering for equipment manufacturers, panel builders and virtually any OEM that has a need for power distribution within their equipment. The OEM interior offering consists of a wide variety of power distribution options utilizing components from Eaton's CH and BR loadcenter product lines. With high-volume, standardized products, OEMs can expect to receive high-quality products covering configurations meeting virtually any power distribution need.

Coupled with Eaton's expertise in circuit breaker design and manufacturing, OEM interiors provide solid power distribution and circuit protection in a compact, easy-to-install package. Interiors are offered from 2 to 42 circuits and from 70 to 225 A.

### Quality

Built in ISO 9002 certified manufacturing facilities, customers can be assured of the process quality in place for the manufacture of these products. Utilizing the latest in computer-controlled plating, painting, molding, stamping and welding processes, Eaton's customers have come to expect consistent high-quality from shipment to shipment.

### Two Products Offer Design Flexibility

As a manufacturer of two lines of loadcenters, Eaton is in a unique position to offer the broadest range of interiors in the market. Each line has its own unique characteristics that appeal to various segments of the market. OEM interiors are UL recognized components and are listed in either of the following UL files: E8741 or E52977.

The CH interiors feature 100% copper bus and use the CH 3/4-inch (19.1 mm) wide circuit breaker, which minimizes panel space. Recognized by contractors for its sturdy design, the CH interior will appeal to those customers seeking an industrial quality bolted busbar and the space saving of 3/4-inch (19.1 mm) per bus stab. With a typical 12 circuit CH interior, this space savings amounts to an inch and a half savings over its 1-inch (25.4 mm) counterparts. The stab rating of the CH interiors is 140 A maximum meaning that the handle rating of breakers mounted across from one another may not exceed 140 A.

The BR interiors are manufactured of formed, plated aluminum or copper, and use Eaton's Type BR 1-inch (25.4 mm) wide circuit breaker. This design affords customers the most circuit flexibility as many of these interiors allow the installation of standard single- and two-pole breakers as well as duplex (two poles in a 1-inch (25.4 mm) space) or quadplex (four poles in a 2-inch (50.8 mm) space) breakers.

The stab rating of the BR interiors is 200 A maximum, meaning that the handle rating of the breakers that are mounted across from one another may not exceed 200 A.

The interiors are designed for either horizontal (single-row breaker mounting), or vertical (double-row breaker mounting). To comply with National Electrical Code (NEC) requirements, if mounted horizontally, when the breaker is ON, the handle should be in the UP position. When mounted vertically, the handle toggles from left to right, so this is not a concern.

#### 1

### Standards and Certifications

#### Class CTL

National Electrical Code Paragraph 384.15 requires branch circuit panelboards to be provided with physical means to prevent the installation of more overcurrent devices than that number of which the enclosure was designed, rated and approved. Class CTL Duplex, Quadplex and twin breakers (identified by a catalog number prefix BD, BQ, BQC and CHT) are equipped with a UL listed rejection tab over the line terminal. All OEM interiors have appropriately notched stabs to accept these rejection tab Class CTL breakers.

Duplex, Quadplex and twin breakers manufactured without the rejection tab (identified by a catalog number prefix BR, BRD and CHT) are available for replacement purposes in older interiors.

#### Federal Specifications

All loadcenter enclosures meet Federal Specifications W-P-115b, Type 1, Class 2 requirements.

All 120/240 V breakers, both 1-inch (25.4 mm), 1/2-inch (12.7 mm) and 3/4-inch (19.1 mm) per pole meet the requirement of Federal Specifications W-C 375B/Gen Type 1.

#### Canadian Standards Association Listing

All single-pole and two-pole, 120/240 V breakers, both 1-inch (25.4 mm), 1/2-inch (12.7 mm) and 3/4-inch (19.1 mm) per pole, 225 A maximum, are listed as Certified by the Canadian Standards Association, Guide No. 69-11.19, Class 1432, File 18328.

#### Underwriters Laboratories Listing

All grounding bars manufactured comply with Underwriters Laboratories standards and are listed under Guide No. DHJR, File E31424, Volume W, Section 17.

All circuit breakers 10 A and larger comply with the Underwriters Laboratories "Standard for Branch Circuit and Service Circuit-Breakers" UL 489; Guide No. 60 10.2 File E31424, and "Requirements for Wire Connectors and Soldering Lugs," UL 486B, Guide No. 461 10-C File E7830.

All Eaton breakers where marked, are suitable for use with 60/75 °C rated wire, unless otherwise specified.

All devices comply with the 22 kAIC–10 kAIC UL series connected components File DKSY2 of the Recognized Components Index.

#### Lighting and Appliance Panelboards

Lighting and appliance branch circuit panelboards are defined in NEC (Article 408) as "One having more than 10 percent of its overcurrent devices rated 30 A or less for which neutral connections are provided." Article 408 also limits the number of overcurrent devices (branch circuit poles) to a maximum of 42 in any one cabinet. When the 42 poles are exceeded, two or more separate panels are required.

For more details and engineering drawings, see BR.31.02.S.E.



### Product Selection

#### Type CH Loadcenter Interior Assemblies—Copper Bus

Ampere Rating	Maximum Number 1-Inch (24.5 mm) Spaces		UL File Reference	Main Terminal Size (Per Phase)	Standard Package Quantity	Catalog Number
	Single Poles					
<b>Single-Phase Single Row Breaker Mounting—120/240 Vac, Three-Wire</b>						
70	2	2	E8741	(1) #8–#2 AWG Cu/Al	1	CH9MB270
125	2	2	E8741	(1) 2/0–#6 AWG Cu/Al	20	CH2L125INT
<b>Single-Phase Double Row Breaker Mounting—120/240 Vac, Three-Wire</b>						
125	4	4	E8741	(1) 2/0–#14 AWG Cu/Al	20	CH4L125INT
125	8	8	E8741	(1) 2/0–#6 AWG Cu/Al	20	CH8L125INT
125	12	12	E8741	(1) 2/0–#6 AWG Cu/Al	20	CH12L125INT
125	16	16	E8741	(1) 2/0–#6 AWG Cu/Al	20	CH16L125INT
200	12	12	E8741	(1) 300 kcmil–#4 AWG Cu/Al	20	CH12L200INT
200	16	16	E8741	(1) 300 kcmil–#4 AWG Cu/Al	10	CH16L200INT
225	24	24	E8741	(1) 300 kcmil–#4 AWG Cu/Al	10	CH24L225INT
225	32	32	E8741	(1) 300 kcmil–#4 AWG Cu/Al	10	CH32L225INT
225	42	42	E8741	(1) 300 kcmil–#4 AWG Cu/Al	10	CH42L225INT
<b>Three-Phase Double Row Breaker Mounting—208Y/120 Vac, Four-Wire—240 Vac, Three-Wire—120/240 Vac, Four-Wire Delta</b>						
125	12	12	E8741	(1) 2/0–#6 AWG Cu/Al	10	CH12L3125INT
125	18	18	E8741	(1) 2/0–#6 AWG Cu/Al	10	CH18L3125INT
125	24	24	E8741	(1) 2/0–#6 AWG Cu/Al	10	CH24L3125INT
225	24	24	E8741	(1) 300 kcmil–#4 AWG Cu/Al	10	CH24L3225INT
225	30	30	E8741	(1) 300 kcmil–#4 AWG Cu/Al	10	CH30L3225INT
225	42	42	E8741	(1) 300 kcmil–#4 AWG Cu/Al	10	CH42L3225INT

BR Loadcenter Interior Assembly



### Type BR Loadcenter Interior Assemblies—Aluminum Bus

Ampere Rating	Maximum Number 1-Inch (24.5 mm) Spaces	Single Poles	UL File Reference	Main Terminal Size (Per Phase)	Standard Package Quantity	Catalog Number
<b>Single-Phase Single Row Breaker Mounting—120/240 Vac, Three-Wire</b>						
70	2	4	E8741	(1) #8-#2 AWG Cu/Al	20	24INT70B
125	2	4	E8741	(1) 1/0-#14 AWG Cu 2/0-12 AWG Al	20	24INT125B
125	6	12	E52977	(1) 2/0-#14 AWG Cu/Al	20	612INT125SRB
<b>Single-Phase Double Row Breaker Mounting—120/240 Vac, Three-Wire</b>						
125	4	8	E8741	(1) 2/0-#14 AWG Cu/Al	20	48INT125B
125	6	12	E8741	(1) 2/0-#14 AWG Cu/Al	20	612INT125B
125	8	16	E8741	(1) 2/0-#14 AWG Cu/Al	20	816INT125B
125	12	12	E52977	(1) 2/0-#14 AWG Cu/Al	20	1212INT125B
125	12	24	E52977	(1) 2/0-#14 AWG Cu/Al	20	1224INT125B
125	16	24	E52977	(1) 2/0-#14 AWG Cu/Al	20	1624INT125B
125	20	24	E52977	(1) 2/0-#14 AWG Cu/Al	10	2024INT125B
125	24	24	E52977	(1) 2/0-#14 AWG Cu/Al	10	2424INT125B
200	8	16	E52977	(1) 300 kcmil-#1 AWG Cu/Al	20	816INT200B
200	12	24	E52977	(1) 300 kcmil-#1 AWG Cu/Al	20	1224INT200B
200	30	40	E52977	(1) 300 kcmil-#1 AWG Cu/Al	10	3040INT200B
225	42	42	E52977	(1) 300 kcmil-#1 AWG Cu/Al	10	4242INT225B
<b>Three-Phase Double Row Breaker Mounting—208Y/120 Vac, Four-Wire—240 Vac, Three-Wire—120/240 Vac, Four-Wire Delta</b>						
125	12	24	E52977	(1) 2/0-#8 AWG Cu/Al	10	1224INT3125B
150	18	36	E52977	(1) 300 kcmil-#2 AWG Cu/Al	10	1836INT3150B
150	24	42	E52977	(1) 300 kcmil-#2 AWG Cu/Al	10	2442INT3150B
200	30	42	E52977	(1) 300 kcmil-#2 AWG Cu/Al	10	3042INT3200B
225	42	42	E52977	(1) 300 kcmil-#2 AWG Cu/Al	10	4242INT3225B

### Type BR Loadcenter Interior Assemblies—Copper Bus

Ampere Rating	Maximum Number 1-Inch (24.5 mm) Spaces	Single Poles	UL File Reference	Main Terminal Size (Per Phase)	Standard Package Quantity	Catalog Number
<b>Single-Phase Double Row Breaker Mounting—120/240 Vac, Three-Wire</b>						
125	8	16	E5297	(1) 2/0-#14 AWG Cu/Al	20	816INT125BC
125	12	12	E5297	(1) 2/0-#14 AWG Cu/Al	20	1212INT125BC
200	12	24	E5297	(1) 300 kcmil-#1 AWG Cu/Al	20	1224INT200BC
<b>Three-Phase Double Row Breaker Mounting—208Y/120 Vac, Four-Wire—240 Vac, Three-Wire—120/240 Vac, Four-Wire Delta</b>						
125	12	24	E52977	(1) 2/0-#8 AWG Cu/Al	10	1224INT3125BC
200	12	24	E52977	(1) 300 kcmil-#2 AWG Cu/Al	10	1224INT3200BC



# 1.3

## Loadcenters and Circuit Breakers

### Loadcenter Interiors/OEM Loadcenters

#### 1

#### Neutral Assemblies

Ampere Rating	UL File Rating	Main Incoming Terminal Wire Size Range 60 °C or 75 °C	Number of Terminals		Standard Package Quantity	Figure	Dimensions—Inches (mm)		Catalog Number
			#14–4 AWG Cu/Al	#6–1/0 AWG Cu #6–2/0 AWG Al			Overall Length A	Mounting B	
125	E52977	#6–1/0 AWG Cu #6–2/0 AWG Al	10	—	20	1	5.938 (150.83)	5.400 (137.16)	10NEU125B
125	E52977	#6–1/0 AWG Cu #6–2/0 AWG Al	17	—	20	1	8.388 (213.06)	7.850 (199.40)	17NEU125B
125	E52977	#6–1/0 AWG Cu #6–2/0 AWG Al	20	—	20	1	9.438 (239.73)	8.900 (226.06)	20NEU125B
225	E52977	#1–300 kcmil Cu/Al	24	1	20	2	10.913 (277.19)	10.300 (261.62)	24NEU225B
225	E52977	#1–300 kcmil Cu/Al	35	1	20	2	15.813 (401.65)	15.200 (386.08)	35NEU225B
125	—	—	4	2	1	3	2.266 (57.56)	0.594 (15.09)	BINA

Figure 1

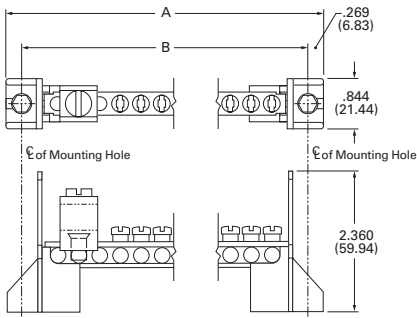

Figure 3

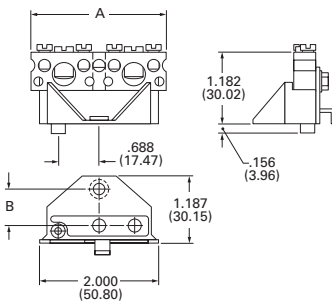
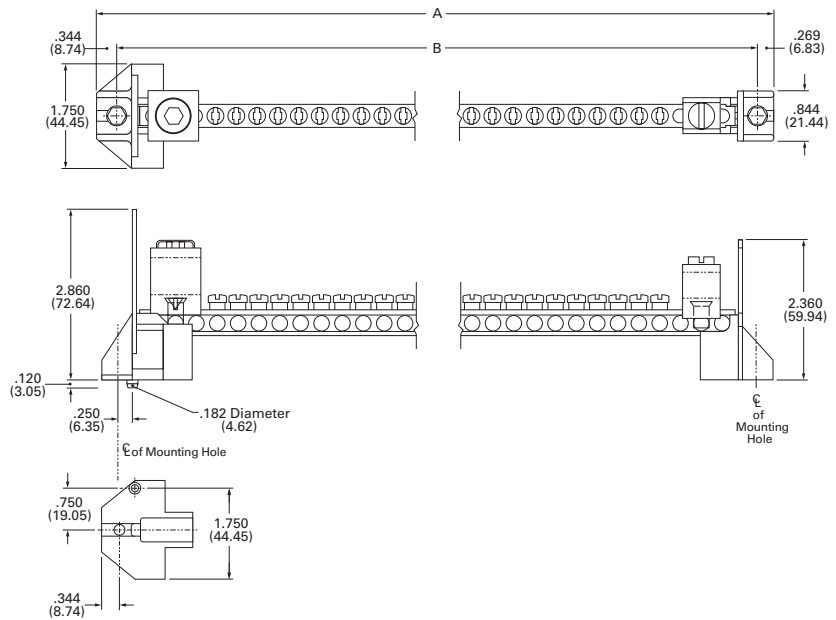

Figure 2



### Add-on Lugs for Neutral Assemblies

Description	Wire Size Range Cu/Al 60 °C or 75 °C	Ordering Quantity <sup>①</sup>	Catalog Number
Neutral/ground lug	#2/0 maximum	1	NL20
Add-on neutral or ground lug	#3/0 maximum	1	NL30
	300 kcmil maximum	1	NL300

GBK14



BRGBK39512



### Ground Bar Kits

Description (See Legend)	Length Inches (mm)	Ordering Quantity <sup>①</sup>	Catalog Number
●○○○○●○	2.54 (64.5)	1	GBK5 <sup>②</sup>
●○○○○●○■	3.59 (91.2)	1	GBK520 <sup>②</sup>
●○○○○●○○○○○	4.29 (109.0)	1	GBK10 <sup>②</sup>
●○○○○●○○○○○■	5.34 (135.6)	1	GBK1020 <sup>②</sup>
○●○○○○○■●○○○○○	4.61 (117.1)	1	GBK13 <sup>②</sup>
●○○○○●○○○○○○○○○	5.69 (144.5)	1	GBK14 <sup>②</sup>
●○○○○●○○○○○○○○○■	6.74 (171.2)	1	GBK1420 <sup>②</sup>
●○○○○●○○○○○○○○○○○○○	8.14 (206.8)	1	GBK21 <sup>②</sup>
●○○○○●○○○○○○○○○○○○○■	9.19 (233.4)	1	GBK2120 <sup>②</sup>
○■●●●○■○○○○○■●●●○■	5.78 (146.8)	1	BRGBK39512 <sup>③④</sup>

#### Ground Bar Legend

- (3) #14–10 Cu/Al or (1) #14–4 Cu/Al
- (1) #6–2/0 Cu/Al
- (1) #14–1/0 Cu/Al or (3) #14–10 Cu/Al
- (1) #14–6 Cu/Al or (2) #14–12 Cu/Al
- Mounting Hole

#### Notes

- ① Must be purchased in multiples of ordering quantities indicated.
- ② Distance between mounting holes is 1.75 inches (44.5 mm).
- ③ For single- and three-phase 400 and 600 A applications.
- ④ Distance between mounting holes is 2.34 inches (59.5 mm).

# 1.4

## Loadcenters and Circuit Breakers

### Enclosed Breakers

1

#### Enclosed Breakers



#### Contents

##### Description

Product Selection .....	V1-T1-95
Dimensions .....	V1-T1-95

##### Page

V1-T1-95
V1-T1-95

#### Product Overview

Eaton enclosed breakers offer all the advantages of circuit breakers packed in an enclosure for 240 Vac applications and include a wide range of accessories.

#### Product Description

- 100–225 A, 240 Vac maximum
- NEMA 1 general purpose—surface or flush mounting
- NEMA 3R rainproof surface mounting

#### Standards and Certifications

- UL 489
- CSA 22.2
- NEMA 250



### Product Selection

#### Single-Phase and Three-Phase Circuit Breaker Enclosures—10/25 kAIC

##### ECC225R



#### Type ECC Circuit Breaker Enclosure—Order Type CC Circuit Breaker Separately

Main Ampere Rating	Unit Enclosure Type	Mounting Type	Circuit Breaker Type	Wire Size Range Cu/Al 60 °C or 75 °C	Catalog Number
<b>Single- and Three-Phase—240 Vac Maximum</b>					
100	Indoor	Surface	CCVH factory installed (25 kAIC)	#4–4/0	<b>ECCVH100S</b> ①②③
150	Indoor	Surface	CCVH factory installed (25 kAIC)	#4–4/0	<b>ECCVH150S</b> ①②③
200	Indoor	Surface	CCVH factory installed (25 kAIC)	#2/0–300 kcmil	<b>ECCVH200S</b> ①②③
100	Outdoor	—	CCVH factory installed (25 kAIC)	#4–4/0	<b>ECCVH100R</b> ①②④
150	Outdoor	—	CCVH factory installed (25 kAIC)	#4–4/0	<b>ECCVH150R</b> ①②④
200	Outdoor	—	CCVH factory installed (25 kAIC)	#2/0–300 kcmil	<b>ECCVH200R</b> ①②④
225	Indoor	Flush	CC/CCV/CCH	⑥	<b>ECC225F</b> ②③⑥
225	Indoor	Surface	CC/CCV/CCH	⑥	<b>ECC225S</b> ②③⑤
225	Outdoor	—	CC/CCV/CCH	⑥	<b>ECC225R</b> ②③④⑤

##### CCV2200



#### Circuit Breaker 240 Vac for Use in Type ECC Enclosures

Ampere Rating	Wire Size Range Cu/Al 60 °C or 75 °C for Line Terminals	Type CCV and CC 10 kAIC Catalog Number	Type CCVH/CCH 25 kAIC Catalog Number
<b>Two-Pole</b>			
60	#4–4/0	<b>CCV2060</b>	<b>CCVH2060</b>
70		<b>CCV2070</b>	<b>CCVH2070</b>
80		<b>CCV2080</b>	<b>CCVH2080</b>
90		<b>CCV2090</b>	<b>CCVH2090</b>
100		<b>CCV2100</b>	<b>CCVH2100</b>
125		<b>CCV2125</b>	<b>CCVH2125</b>
150		<b>CCV2150</b>	<b>CCVH2150</b>
175	#2/0–300 kcmil	<b>CCV2175</b>	<b>CCVH2175</b>
200		<b>CCV2200</b>	<b>CCVH2200</b>
225		<b>CCV2225</b>	<b>CCVH2225</b>
<b>Three-Pole</b>			
100	#4–4/0	<b>CC3100</b>	<b>CCH3100</b>
125		<b>CC3125</b>	<b>CCH3125</b>
150		<b>CC3150</b>	<b>CCH3150</b>
175	#2/0–300 kcmil	<b>CC3175</b>	<b>CCH3175</b>
200		<b>CC3200</b>	<b>CCH3200</b>
225		<b>CC3225</b>	<b>CCH3225</b>

#### Shunt Trips and Auxiliary Contacts

Description Type	Volts	Catalog Number Suffix Adder ⑦
<b>Shunt Trip</b>		
CC	12 DC	<b>SR12</b>
CC	24 DC	<b>SR24</b>
CC	120 AC	<b>SR01</b>
CC	208 AC	<b>SR08</b>
CC	240 AC	<b>SR02</b>
CCV	48–127 AC/48–60 DC	<b>SR01</b>
CCV	9–24 AC/12–24 DC	<b>SR02</b>
CCV	208–380 AC/100–127 DC	<b>SR04</b>
<b>Auxiliary Contact</b>		
CC 1NO and 1NC	—	<b>AL1</b>

#### Dimensions

Approximate Dimensions in Inches (mm)

##### ECC Unit Enclosures—NEMA Type 1 Indoor

Height	Width	Depth
23.25 (590.6)	8.88 (225.4)	4.50 (114.3)

##### ECC Unit Enclosures—NEMA Type 3R Outdoor

Height	Width	Depth
23.68 (601.7)	9.31 (236.5)	5.44 (138.1)

#### Notes

- ① Factory installed CCVH breaker.
- ② Approved for service entrance.
- ③ One ground lug accepting (1) #14–#2 is factory installed. Also, there are pre-drilled holes to accept a GBK5 ground bar.
- ④ Rainproof panels are furnished with hub closures plates. For rainproof hubs, refer to **Page V1-T1-68**.
- ⑤ Order circuit breaker separately.
- ⑥ Wire size is determined by the circuit breaker installed in enclosure.
- ⑦ Add suffix indicated to end of breaker catalog number.



### Product Description

Eaton UL classified Replacement Circuit Breakers are available in both 3/4-inch Type CHQ and 1-inch Type CL, single- and two-pole configurations. These breakers are classified as direct replacements by Underwriters Laboratories. In addition to a UL listing, they also come with a 15-year warranty.

### Specified vs. UL Classified

Specified breakers are listed by the manufacturer of the panelboard for use in a particular panel. This doesn't mean that the panelboard manufacturer produced the specified breaker; it merely means that the panelboard manufacturer has tested the breaker in the panel. In fact, through the years, Eaton has manufactured thousands of breakers for other panelboard manufacturers.

UL classified breakers are produced by one manufacturer for use in place of the breakers specified on the panelboard. Like specified breakers, UL classified breakers have been tested in the panels for which they are approved.

### Contents

<i>Description</i>	<i>Page</i>
Product Selection . . . . .	V1-T1-97
Accessories . . . . .	V1-T1-99
Technical Data . . . . .	V1-T1-99
Wiring Diagrams . . . . .	V1-T1-100

### Testing

Classified breakers are tested extensively in numerous General Electric®, Siemens®, Murray®, Thomas & Betts®, Square D®, and Crouse-Hinds® panels. The tests are conducted with witnesses from Underwriters Laboratories Inc. and involve short-circuit, temperature, and insertion/withdrawal applications. This level of testing ensures that the breakers meet identified standards and have been found suitable by UL for the specified purpose.

### Understanding Classified Breaker Terminology

#### Definitions

**Specified circuit breaker**—each manufacturer lists the brands of circuit breakers that can be used in their panelboards. Often, manufacturers will not list competitors as specified, even though they are suitable replacements.

**Classified circuit breaker**—a breaker that is considered suitable, by a qualified third-party organization, for use in another manufacturer's panelboard.

**Listed breaker**—the listing of a circuit breaker is by an independent third party. Eaton classified breakers are listed by UL.

**Labeled breaker**—a breaker with a label affixed by an independent third party.

## Product Selection

### Type CHQ Replacement Breakers for Square D Type QO Loadcenters

10 kAIC, 120 and 120/240 Vac

CHQ120 CHQ230



### Type CHQ Classified Breakers 3/4-Inch (19.1 mm) per Pole 120 or 120/240 Vac, 10 kAIC

Ampere Rating	Wire Size Range Cu/Al 60 °C or 75 °C	Catalog Number	
		Single-Pole 120/240 Vac Requires One 3/4-Inch (19.1 mm) Space 10 per Shelf Carton	Two-Pole 120/240 Vac Common Trip Requires Two 3/4-Inch (19.1 mm) Spaces 5 per Shelf Carton
15	(1) #14–8	CHQ115	CHQ215
20	(2) #14–10	CHQ120	CHQ220
25		CHQ125	CHQ225
30		CHQ130	CHQ230
35		CHQ135	CHQ235
40		CHQ140	CHQ240
45		CHQ145	CHQ245
50		CHQ150	CHQ250
60		—	CHQ260

### Type CHQ Surge Arrester

Catalog Number
CHQSA

# 1.5

## Loadcenters and Circuit Breakers

### Classified Circuit Breakers

1

#### Type CL Replacement Breakers for Square D HOMELINE, General Electric, Crouse-Hinds, Thomas & Betts, Murray and ITE®/Siemens Loadcenters

CL\_

##### Type CL Breakers, 1-Inch (25.4 mm) per Pole, 10 kAIC



Single-Pole 120/240 V  
Requires One  
1-Inch (25.4 mm) Space  
10 per Shelf Carton  
Catalog Number



Two-Pole 120/240 V  
Common Trip Requires Two  
1-Inch (25.4 mm) Spaces  
5 per Shelf Carton  
Catalog Number

Ampere Rating	Wire Size Range Cu/Al 60 °C or 75 °C	Single-Pole 120/240 V Requires One 1-Inch (25.4 mm) Space 10 per Shelf Carton Catalog Number	Two-Pole 120/240 V Common Trip Requires Two 1-Inch (25.4 mm) Spaces 5 per Shelf Carton Catalog Number
15	#14-4	CL115	CL215
20	#14-4	CL120	CL220
25	#14-4	CL125	CL225
30	#14-4	CL130	CL230
35	#14-4	CL135	CL235
40	#14-4	CL140	CL240
45	#14-4	CL145	CL245
50	#14-4	CL150	CL250

CL\_AF

##### Type CL Classified Arc and Ground Fault Breakers (5 Milliampere), 1-Inch (25.4 mm) per Pole, 10 kAIC

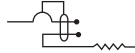

Single-Pole 120/240 V  
Requires One 1-Inch (25.4 mm) Space  
1 per Shelf Carton  
Catalog Number

Ampere Rating	Wire Size Range Cu/Al 60 °C or 75 °C	Single-Pole 120/240 V Requires One 1-Inch (25.4 mm) Space 1 per Shelf Carton Catalog Number
<b>Arc Fault Breakers</b>		
15	#14-4	CL115AF
20	#14-4	CL115CAF
20	#14-4	CL120AF
20	#14-4	CL120CAF
<b>Ground Fault Breakers</b>		
15	#14-4	CL115GFT
20	#14-4	CL120GFT
30	#14-4	CL130GFT

CLR\_

##### Type CL Classified Latching Remote Control Smart Breakers™, 1-Inch (25.4 mm) per Pole, 10 kAIC



Single-Pole 120 V  
Requires One  
1-Inch (25.4 mm) Space  
10 per Shelf Carton  
Catalog Number



Two-Pole 120/240 V  
Common Trip Requires Two  
1-Inch (25.4 mm) Spaces  
5 per Shelf Carton  
Catalog Number

Ampere Rating	Wire Size Range Cu/Al 60 °C or 75 °C	Single-Pole 120 V Requires One 1-Inch (25.4 mm) Space 10 per Shelf Carton Catalog Number	Two-Pole 120/240 V Common Trip Requires Two 1-Inch (25.4 mm) Spaces 5 per Shelf Carton Catalog Number
15	(2) #14-10	CLRP115	CLRP215
20	(2) #14-10	CLRP120	CLRP220
25	(1) #8-6	CLRP125	CLRP225
30	(1) #8-6	CLRP130	CLRP230

## Accessories

### CHQ Breaker Accessories

Description	Catalog Number
Breaker handle lock	CHLO

## Technical Data

### Arc Fault Application Notes

An arc fault circuit interrupter is a device intended to provide protection from the effects of arc faults by recognizing characteristics unique to arcing and by functioning to de-energize the circuit when the arc fault is detected. As of January 1, 2002, the National Electrical Code (NEC) requires all branch circuits that supply 125 V, single-phase, 15 and 20 A receptacle outlets installed in dwelling unit bedrooms shall be protected by an arc fault circuit interrupter(s). This includes ceiling lighting (recessed, ceiling fans, etc.) as well as smoke detectors and all other bedroom outlets. The 2005 NEC introduced the application of the Combination Type AFCI for bedroom circuits required as of January 1, 2008. The 2008 NEC expands this application to other living areas.

### Ground Fault Application Notes

Single-pole GFTCBs are designed for use in two-wire, 120 Vac circuits. Drawing on **Page V1-T1-100** shows a typical wiring configuration.

Two-pole GFTCBs are designed for use in three-wire, 120/240 Vac circuits, 120 Vac multiwire circuits employing common, neutral and two-wire, 240 Vac circuits obtained from a 120/240 Vac source.

Drawings on **Page V1-T1-100** illustrate typical wiring configurations for 120/240 Vac multiwire circuits.

Drawing on **Page V1-T1-100** depicts a 240 Vac, two-wire circuit. Note the “panel neutral” conductor connects to the neutral bar, even though the neutral is not included in the load circuit. This connection is necessary to supply a 120 Vac power source to the ground fault sensing circuit.

The figures are shown with a 120/240 Vac, single-phase, three-wire power source, but are also applicable to a 120/208 Vac, three-phase, four-wire power supply. For all figures, the electrical operation of the GFTCB is not affected by the equipment ground.



# 1.5

## Loadcenters and Circuit Breakers

### Classified Circuit Breakers

#### 1 Wiring Diagrams Single-Pole 120 V Load Application Sourced by 120/240 Vac

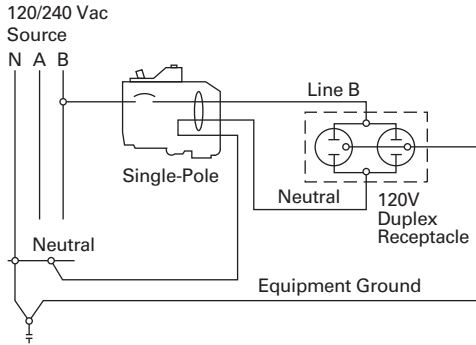

#### Two-Pole 240 V Load Application Sourced by 120/240 Vac

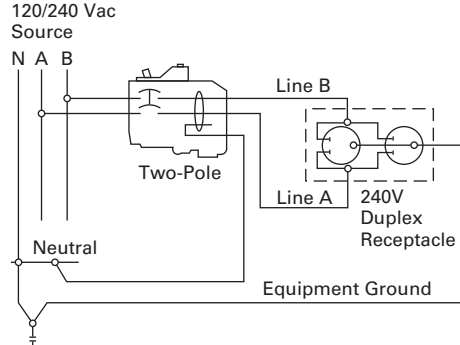

#### Two-Pole Shared Neutral with Multi-Duplex Receptacle Application

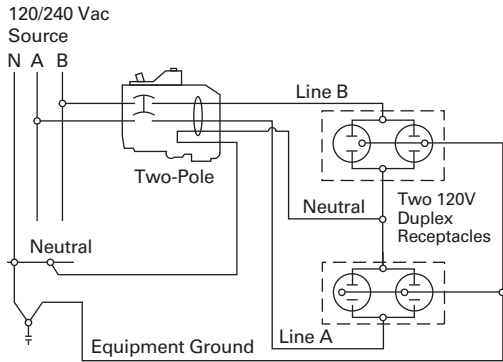

#### Two-Pole Shared Neutral with Duplex Receptacle Application

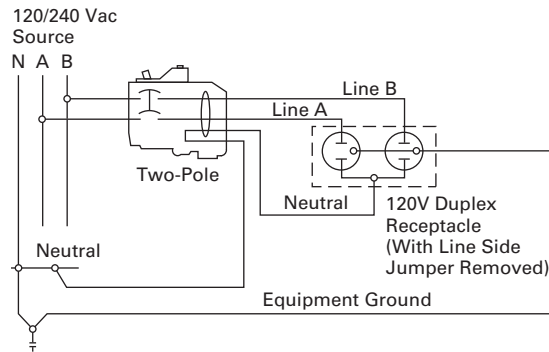

#### Single-Pole 120 V Duplex Receptacle Application

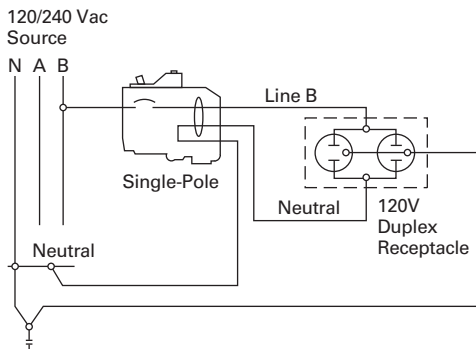

#### Two-Pole 120 V Duplex Receptacle Application

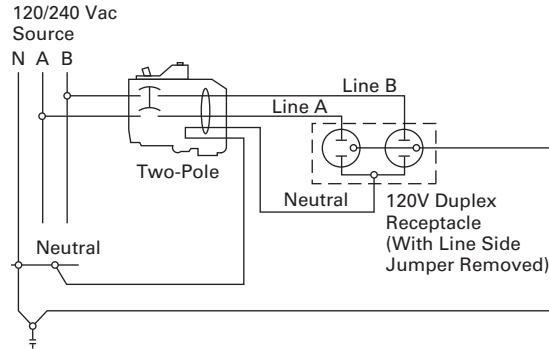

#### Two-Pole 120 V Multi-Duplex Receptacle Application

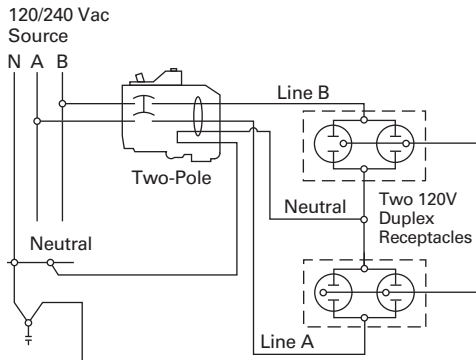

#### Two-Pole 240 V Duplex Receptacle Application

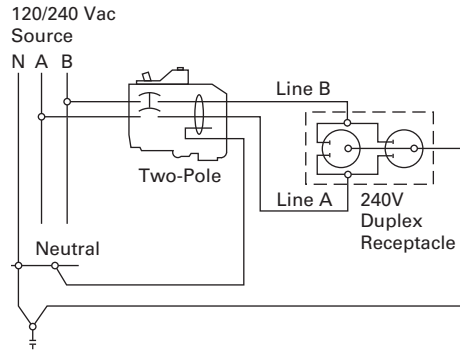

**Surge Protection Devices**



**2.1 Surge Protection Devices and Lightning Arresters**

- Product Description ..... V1-T2-2
- Application Description ..... V1-T2-2
- Standards and Certifications ..... V1-T2-3
- Product Selection ..... V1-T2-4



# 2.1

## Surge Protection

### Surge Protection Devices and Lightning Arresters

#### Surge Protection Devices

2



#### Product Description

Due to the evolution of electronics and microprocessors in the home, there is a continuous challenge to provide quality (clean) power for electronic loads such as appliances, computers/home office and entertainment systems. Surges caused by lightning, utility grid switching and other sources travel on current carrying conductors throughout the home, which can affect and destroy sensitive electronic loads.

Eaton offers a comprehensive family of surge products for use at service entrances. These products can help protect sensitive electronics against the damaging effects of surges.

#### Application Description

##### Two-Stage Protection

Two stages of surge suppression are recommended to provide the best protection for electronic equipment. Two-stage surge suppression should be provided for all cables entering a home, including power, Internet and coaxial.

##### Service Entrance Surge Protection

Eaton's service entrance surge protection units provide premier surge protection for AC power at the service entrance. These products provide protection for residential electrical equipment by reducing power surges to an acceptable level for surge strips to handle at the point of use.

##### UL 1449 3rd Edition Type 1 and Type 2 Surge Protection

- **Type 1 Surge Protective Device (SPD)**— Permanently connected Type 1 SPDs are intended for installation between the secondary of the service transformer and the line side of the service equipment overcurrent device, as well as the load side, including watt-hour meter socket enclosures, and are intended to be

#### Contents

##### Description

	<i>Page</i>
Surge Protection Devices and Lightning Arresters	
Standards and Certifications . . . . .	<b>V1-T2-3</b>
Product Selection . . . . .	<b>V1-T2-4</b>

installed without an external overcurrent protective device. Type 1 devices are dual-rated for Type 2 applications as well, providing the highest ratings available for installation at the service entrance

- Eaton's CHSPT1 products provide Type 1 surge protection in accordance with UL® 1449 3rd Edition. These units can be universally mounted outside any manufacturer's primary service equipment
- **Type 2 Surge Protective Device**—Permanently connected Type 2 SPDs are intended for installation on the load side of the service equipment overcurrent device, including SPDs located at the branch panel
  - CHSPT2 products provide Type 2 surge protection in accordance with UL 1449 3rd Edition. These units can be mounted outside of any manufacturer's loadcenter or inside an Eaton Surge/Surge Ready loadcenter. Eaton also offers accessories to the CHSPT2 line for cable protection

- **Factory-Installed Surge Protection**—Eaton's loadcenters with factory-installed surge protection include a CHSPT2ULTRA and a two-pole 50 A circuit breaker. These loadcenters increase the effectiveness of surge protection due to reduced lead length. A modified deadfront allows for easy viewing of indicating lights for status indication



Surge Panel

- **Surge Ready Loadcenter**—The Surge Ready loadcenter provides a mounting provision for the CHSPT2ULTRA. This loadcenter has a modified deadfront to allow for viewing of indicating lights

### Two-Stage Protection



① CHSP installed at the service entrance panel.

② SurgeTrap™ surge traps and strips located where sensitive electronics are plugged in.

### Plug-On Surge Protection

- **Type CHSA**—For use on single-phase 120/240 Vac systems. The CHSA easily plugs into a single-phase Type CH loadcenter and occupies two 3/4-inch (19.1 mm) pole spaces, similar to a two-pole Type CH breaker. When installed properly, it provides surge protection for the entire loadcenter. If internal components are damaged, the CHSA LED visual indicators will signal the need for a replacement. This device is suitable for service entry locations when installed in accordance with NEC® guidelines
- **Type BRSURGE**—For use on single-phase 120/240 Vac systems. This easily plugs into a single-phase Type BR loadcenter and occupies two 1-inch (25.4 mm) pole spaces similar to a two-pole Type BR breaker. When installed properly, it provides surge protection for the entire loadcenter. If internal components are damaged, the BRSURGE LED visual indicators will signal the need for replacement. This device is suitable for service entry locations when installed in accordance with NEC guidelines
- **Type CLSURGE**—For use on single-phase 120/240 Vac systems. CLSURGE easily plugs into a single-phase Type BR loadcenter and occupies two 1-inch (25.4 mm) pole spaces similar to a two-pole Type BR breaker. When installed properly, it provides surge protection for the entire loadcenter. If internal components are damaged, the CLSURGE LED visual indicators will signal the need for replacement. This device is suitable for service entry locations when installed in accordance with NEC guidelines. This unit is also classified by UL for use in select GE, ITE/Siemens and Crouse-Hinds panels
- **Type CHQSA**—For use on single-phase, 120/240 Vac systems. This unit easily plugs into a Square D single-phase loadcenter Type QO® and occupies two 3/4-inch (19.1 mm) pole spaces similar to a two-pole Type QO breaker. When installed properly, it provides surge protection for the entire loadcenter. If internal components are damaged, the CHQSA LED visual indicators will signal the need for a replacement. This device is suitable for service entrance locations installed in accordance with NEC guidelines. This device is UL classified to be used in place of Square D Type QO surge arresters (refer to Pub-23974)
- **Type BRSURGECSA**—For use on single-phase 120/240 Vac systems. This easily plugs into a single-phase Type BR loadcenter and occupies two 1-inch (25.4 mm) pole spaces similar to a two-pole Type BR breaker. When installed properly, it provides surge protection for the entire loadcenter. If internal components are damaged, the BRSURGECSA LED visual indicators will signal the need for replacement. This device is suitable for service entry locations when installed in accordance with Canadian Electrical Code. This device is CSA® listed to be used in a Type BR loadcenter

### Type 3 Point-of-Use Surge Protection

Point-of-use surge protectors such as surge receptacles are installed within 30 ft of conductor length from the service panel and are designed to offer premium surge protection for specific electronics while providing innovative features to enhance user convenience.

### Standards and Certifications

- CHSPT1 Products: UL 1449 3rd Edition Type 1
- CHSPT2 Products: UL/cUL® 1449 3rd Edition Type 2
- CHSPCABLE: UL 6500, cUL
- NEMA® 3R Enclosure for CHSPCABLE: UL 50 Enclosure
- BRSURGE, CHSA, BRSURGECSA, CHQSA, CLSURGE: UL 1449 3rd Edition plug-in type; Type 2 SPD



# 2.1

## Surge Protection

### Surge Protection Devices and Lightning Arresters





#### Product Selection

2

#### SPD Type 1 CHSP Service Entrance Surge Protection—UL 1449 3rd Edition

##### Product Features

- Commercial grade AC power protection
- Type 1 surge device for installation before or after the main service disconnect
- Convenient mounting options—universal fit to any manufacturer’s equipment
- Clear, visible LED indication displaying status of the surge protector

Catalog Number	Connection	Enclosure	Voltage	Phase	Frequency (Hz)	MCOV <sup>①</sup>	VPR <sup>②</sup>	I <sub>n</sub> <sup>③</sup>	SCCR <sup>④</sup>	Surge Current Capacity, Per Phase Rating <sup>⑤</sup>
 CHSPT1ULTRA	Permanently connected device installed before or after the service disconnect overcurrent device.	NEMA 4	100/200 Vac, 110/220 Vac, 120/240 Vac	Single	50/60	300 V L–L, 150 V L–N	1000 V L–L, 600 V L–N	20 kA	200 kA	50 kA
 CHSPT1MAX	Permanently connected device installed before or after the service disconnect overcurrent device.	NEMA 4	100/200 Vac, 110/220 Vac, 120/240 Vac	Single	50/60	300 V L–L, 150 V L–N	1000 V L–L, 600 V L–N	20 kA	200 kA	45 kA
 CHSPT1MICRO	Permanently connected device installed before or after the service disconnect overcurrent device.	NEMA 4	100/200 Vac, 110/220 Vac, 120/240 Vac	Single	50/60	300 V L–L, 150 V L–N	1000 V L–L, 600 V L–N	20 kA	200 kA	36 kA
 CHSPT1-208Y	Permanently connected device installed before or after the service disconnect overcurrent device.	NEMA 4	120/208 Vac	Three-phase wye	50/60	300 V L–L, 150 V L–N	1000 V L–L, 600 V L–N	20 kA	200 kA	50 kA

#### Accessory for Type 1 CHSP Service Entrance Surge Protection

Catalog Number	Description
 SP1DINRAILKIT	Mounting kit for wall or DIN rail installation.

##### Notes



- ① MCOV: Maximum Continuous Operating Voltage that may be applied to the device per mode.
- ② VPR: Voltage Protection Rating is the measured limiting voltage after a surge event.
- ③ I<sub>n</sub>: Nominal Discharge Current is the current that the device can withstand for 15 impulses.
- ④ SCCR: The amount of current the product can withstand under short-circuit conditions.
- ⑤ Surge Current Capacity: The maximum one time surge current rating per phase.

For warranty details, go to [www.eaton.com/surgetrap](http://www.eaton.com/surgetrap).

### SPD Type 2 CHSP Service Entrance Surge Protection—UL 1449 3rd Edition; cUL

#### Product Features

- AC power protection
- Universally connects to any manufacturer's loadcenter (breaker box)
- Quick connect design—easy to mount cable protection modules
- LED status indication

Catalog Number	Connection	Enclosure	Voltage	Phase	Frequency (Hz)	MCOV <sup>①</sup>	VPR <sup>②</sup>	I <sub>n</sub> <sup>③</sup>	SCCR <sup>④</sup>	Surge Current Capacity, Per Phase Rating <sup>⑤</sup>
 <b>CHSPT2ULTRA</b>	Can be attached to the outside of any manufacturer's loadcenter (breaker box). This product should be connected on the load side of the loadcenter main service disconnect through a dedicated circuit breaker (follow NEC Guidelines).	NEMA 4	120/240 Vac rated line voltage	Single	60	150 V L–N, 300 V L–L	600 V L–N, 1000 V L–L, 800 V N–G, 600 V L–G	20 kA <sup>⑥</sup>	22 kA	<b>108 kA</b> (L1–N 54 kA, L1–G 54 kA, L2–N 54 kA, L2–G 54 kA)
 <b>CHSPT2SURGE</b>	Can be attached to the outside of any manufacturer's loadcenter (breaker box). This product should be connected on the load side of the loadcenter main service disconnect through a dedicated circuit breaker (follow NEC Guidelines).	NEMA 4	120/240 Vac rated line voltage	Single	60	150 V L–N, 300 V L–L	600 V L–N, 1000 V L–L, 800 V N–G, 600 V L–G	5 kA	22 kA	<b>36 kA</b> (L1–N 18 kA, L1–G 18 kA, L2–N 18 kA, L2–G 18 kA)

#### Notes

- ① MCOV: Maximum Continuous Operating Voltage that may be applied to the device per mode.
- ② VPR: Voltage Protection Rating is the measured limiting voltage after a surge event.
- ③ I<sub>n</sub>: Nominal Discharge Current is the current that the device can withstand for 15 impulses.
- ④ SCCR: The amount of current the product can withstand under short-circuit conditions.
- ⑤ Surge Current Capacity: The maximum one time surge current rating per phase.
- ⑥ When used with a 50 A two-pole circuit breaker, 10 kA when used with a 15 A two-pole circuit breaker.

For warranty details, go to [www.eaton.com/surgetrap](http://www.eaton.com/surgetrap).





# 2.1

## Surge Protection

### Surge Protection Devices and Lightning Arresters

2

#### Accessories for CHSP Type 2 Service Entrance Protection

Catalog Number	Description	Installation	Surge Current Capacity	DC Breakdown Voltage	Voltage
<b>CHSPCABLE</b> 	<b>CHSPCABLE</b> Quick Connect design—add additional telephone and AC protection modules; protects two quad shield cables; bi-directional	Indoor installation; or rain-tight when used with recommended enclosure	10 kA per line	145 V	
<b>CHSPT2PACK</b> 	<b>CHSPT2PACK</b> 2-Pack: CHSPT2ULTRA + CHSPCABLE; Surge protection for AC power and cable—see individual product features		See individual product ratings		
<b>CHSP3RTELCABLE</b> 	<b>CHSP3RTELCABLE</b> Raintight enclosure for CHSPTELE and CHSPCABLE; top or bottom feed; enclosure only, surge not included; accommodates up to two devices				
<b>CHSPFMKIT</b> 	<b>CHSPFMKIT</b> Flushmount kit for: CHSPT2ULTRA, CHSPT2MAX, CHSPT2SURGE, CHSPCABLE				
<b>MSEGR2</b> 	<b>MSEGR2</b> Outdoor communication grounding device; meets 2008 NEC requirements for intersystem bonding termination				

**Note**

For warranty details, go to [www.eaton.com/surgetrap](http://www.eaton.com/surgetrap).

### Type BR and CH Surge Breakers

#### Product Description

The CH and BR surge breaker is designed to provide premier AC power surge protection for sensitive electronics and appliances from the damaging effects of electrical surges. In addition, the surge breaker is a functional two-pole thermal magnetic breaker.

The combination of circuit protection and surge protection provides extra flexibility and space saving in the loadcenter.

#### Product Features

- Complete home surge protection for all circuits plus a functional two-pole thermal magnetic breaker
- LEDs provide protection status
- Plug-on connection to the busbar provides superior protection and easy installation for new construction or renovation
- Eliminates the potential for incorrect installation of externally mounted surge devices—(longer “lead” lengths can reduce protection levels)

#### Type CH Surge Breakers



Catalog Number <sup>①</sup>	Poles	Ampere Rating	Voltage	Phase	Frequency (Hz)	MCOV <sup>②</sup>	VPR <sup>③</sup>	I <sub>n</sub> <sup>④</sup>	SCCR <sup>⑤</sup>	Surge Current Capacity, Per Phase Rating <sup>⑥</sup>
<b>Type CH Surge Breakers</b>										
<b>CH230SUR</b>	Two-pole 10 kAIC	30	120/240 Vac	Single	50/60	150 V L–N, 300 V L–L	600 V L–N, 1000 V L–L	10 kA	10 kA	36 kA (L1–N 36 kA, L2–N 36 kA)
<b>CH250SUR</b>		50	120/240 Vac	Single	50/60	150 V L–N, 300 V L–L	600 V L–N, 1000 V L–L	10 kA	10 kA	36 kA (L1–N 36 kA, L2–N 36 kA)

#### Type BR Surge Breakers



<b>Type BR Surge Breakers</b>										
<b>BR230SUR</b>	Two-pole 10 kAIC	30	120/240 Vac	Single	50/60	150 V L–N, 300 V L–L	600 V L–N, 1000 V L–L	10 kA	10 kA	36 kA (L1–N 36 kA, L2–N 36 kA)
<b>BR250SUR</b>		50	120/240 Vac	Single	50/60	150 V L–N, 300 V L–L	600 V L–N, 1000 V L–L	10 kA	10 kA	36 kA (L1–N 36 kA, L2–N 36 kA)

#### Notes

- ① Clamshell packaging available with CS modification code on the end of catalog number.
- ② MCOV: Maximum Continuous Operating Voltage that may be applied to the device per mode.
- ③ VPR: Voltage Protection Rating is the measured limiting voltage after a surge event.
- ④ I<sub>n</sub>: Nominal Discharge Current is the current that the device can withstand for 15 impulses.
- ⑤ SCCR: The amount of current the product can withstand under short-circuit conditions.
- ⑥ Surge Current Capacity: The maximum one time surge current rating per phase.



# 2.1

## Surge Protection

### Surge Protection Devices and Lightning Arresters

#### Surge Protection Receptacles with LED Indicators and Audible Alarm

2

##### Product Description

- Two-pole, three-wire grounding
- 15 A, 125 Vac; 20 A, 125 Vac; NEMA 5-15R and 5-20R



➤ ArrowLink option available. Add "M" suffix to standard catalog number (example 8300WS, 8300WSM).

🏠 Build-to-spec customizable devices.

Catalog Number	Color Suffix	Ampere Rating	Voltage	NEMA	Description	➤	🏠
<b>5362_S</b>							
<b>Receptacles with Audible Alarm and LED Indicators, Back and Side Wire</b> cUL <sub>US</sub> NOM 426							
5262__S	BL, GY, V, W	15	125 Vac	5-15R	Surge duplex receptacle	■	■
IG5262__S	BL, GY, RN, V, W				IG Surge duplex receptacle	■	■
5362__S	BL, GY, V, W	20	125 Vac	5-20R	Surge duplex receptacle	■	■
IG5362__S	BL, GY, RN, V, W				IG Surge duplex receptacle	■	■
560 Joules, max. surge current—18 kA per mode							
<b>Receptacles with LED Indicators, Back and Side Wire</b> cUL <sub>US</sub>							
5250__S	BL, GY, V, W	15	125 Vac	5-15R	Surge duplex receptacle	■	■
IG5250__S	BL, GY, RN, V, W				IG Surge duplex receptacle	■	■
5350__S	BL, GY, V, W	20	125 Vac	5-20R	Surge duplex receptacle	■	■
IG5350__S	BL, GY, RN, V, W				IG Surge duplex receptacle	■	■
840 Joules, max. surge current—18 kA per mode							
<b>Receptacles with Audible Alarm</b> cUL <sub>US</sub>							
1208__	V, W	15	125 Vac	5-15R	Surge duplex receptacle	■	■
IG1208__	V, W				IG Surge duplex receptacle	■	■
1210__	BL, V, W	20	125 vac	5-20R	Surge duplex receptacle	■	■
IG1210__	V, W				IG Surge duplex receptacle	■	■
340 Joules, max. surge current—12 kA per mode							



1209



35M2S



Catalog Number	Color Suffix	Ampere Rating	Voltage	Description
<b>Multimedia Wallplates with Surge Protectors</b> cETL <sub>US</sub>				
35M2S__	W	15	125	Multimedia wallplate with recessed duplex surge receptacle
cETL <sub>US</sub> listed to UL1863 & ANSI/UL 60950-1, CSA C22.2 no. 60950-1-03; complies with all TIA/EIA 568-A & 570-B requirements				

Catalog Number	Color Suffix	Description
<b>Replacement Surge Bloc Module</b> UL <sub>US</sub>		
1209__	A, BL, GY, V, W	Replacement module

Catalog Number	Color Suffix	Description
<b>Accessories for Surge Protection Receptacles</b> cUL <sub>US</sub>		
PJ26BL	BL	1-Gang mid-size decorator polycarbonate wallplate
PJ26W	W	1-Gang mid-size decorator polycarbonate wallplate
PJ26IG	RN	1-Gang mid-size decorator polycarbonate wallplate, pre-marked "ISOLATED GROUND"

##### Notes

For ordering devices, include catalog number followed by the color suffix: BL (Blue), GY (Gray), RD (Red), RN (Orange), V (Ivory), W (White)

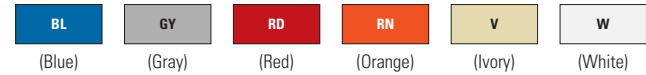

Compliances, specifications and availability are subject to change without notice.

### Factory-Installed Surge Protection

- Includes a CHSPT2ULTRA and a two-pole 50 A circuit breaker
- Increases the effectiveness of surge protection due to reduced lead length
- A modified deadfront allows for easy viewing of indicating lights for status indication

### Surge Installed



### Surge Installed Loadcenters

Catalog Number	Description	Cover Catalog Number	
		Combination	Surface
CHSUR42N225L ①	42 ckt, 225 A, convertible	CHSUR8LF	CHSUR8LS
CHSUR42L225L2 ①	42 ckt, 225 A, convertible ②	CHSUR8LF	CHSUR8LS
CHSUR42B200L2 ①	42 ckt, 200 A, main breaker	CHSUR8LF	CHSUR8LS
CHSUR32N225K ①	32 ckt, 225 A, convertible	CHSUR8KF	CHSUR8KS
CHSUR32L225K ①	32 ckt, 225 A, convertible ②	CHSUR8KF	CHSUR8KS
CHSUR32B200K ①	32 ckt, 200 A, main breaker	CHSUR8KF	CHSUR8KS
CHSUR32B150K ①	32 ckt, 150 A, main breaker	CHSUR8KF	CHSUR8KS
CHSUR32B100K ①	32 ckt, 100 A, main breaker	CHSUR8KF	CHSUR8KS
CHSUR24L125E ①	24 ckt, 125 A, convertible ②	CHSUR8EF	CHSUR8ES
CHSUR24B100E ①	24 ckt, 100 A, main breaker	CHSUR8EF	CHSUR8ES
BRSUR4040N200	40/40 ckt, 200 A, convertible	Cover included	
BRSUR4040L200	40/40 ckt, 200 A, main lug	Cover included	
BRSUR4040B200	40/40 ckt, 200 A, main breaker	Cover included	
BRSUR3040N200	30/40 ckt, 200 A, convertible	Cover included	
BRSUR3040L200	30/40 ckt, 200 A, main lug	Cover included	
BRSUR3040B200	30/40 ckt, 200 A, main breaker	Cover included	

### Surge Ready Loadcenters

- Provides a mounting provision for CHSPT2ULTRA
- A modified deadfront allows for easy viewing of indicating lights

### Surge Ready



### Surge Ready Loadcenters (Provision Only, CHSPT2ULTRA and Breaker Not Included)

Catalog Number	Description	Cover Catalog Number	
		Combination	Surface
CHEC42N225L ①	42 ckt, 225 A, convertible	CHSUR8LF	CHSUR8LS
CHEC42L225L ①	42 ckt, 225 A, convertible ②	CHSUR8LF	CHSUR8LS
CHEC42B200L ①	42 ckt, 200 A, main breaker	CHSUR8LF	CHSUR8LS
CHEC32L225K ①	32 ckt, 225 A, convertible ②	CHSUR8KF	CHSUR8KS
CHEC32N225K ①	32 ckt, 225 A, convertible	CHSUR8KF	CHSUR8KS
CHEC32B200K ①	32 ckt, 200 A, main breaker	CHSUR8KF	CHSUR8KS
CHEC32B150K ①	32 ckt, 150 A, main breaker	CHSUR8KF	CHSUR8KS
CHEC32B100K ①	32 ckt, 100 A, main breaker	CHSUR8KF	CHSUR8KS
CHEC24L125E ①	24 ckt, 125 A, convertible ②	CHSUR8EF	CHSUR8ES
CHEC24B100E ①	24 ckt, 100 A, main breaker	CHSUR8EF	CHSUR8ES

#### Notes

- ① Order cover separately.
- ② With main lugs installed.

# 2.1

## Surge Protection

### Surge Protection Devices and Lightning Arresters

2

#### SPD Type 2 Plug-On Surge Protection—UL 1449 3rd Edition

##### Product Features

- Convenient surge protection for the loadcenter

Catalog Number	Description	Connection	Voltage	Phase	Frequency (Hz)	MCOV <sup>①</sup>	VPR <sup>②</sup>	I <sub>n</sub> <sup>③</sup>	SCCR <sup>④</sup>	Surge Current Capacity, Per Phase Rating <sup>⑤</sup>
<b>BRSURGE</b>	<b>BRSURGE</b> UL for use in a single-phase Type BR loadcenter.	Plug on to the loadcenter bus; see instructions.	120/240 Vac	Single	60	150 V L1–N, 300 V L–L	600 V L1–N, 1000 V L–L	3 kA	10 kA	18 kA
										
<b>CLSURGE</b>	<b>CLSURGE</b> This unit is classified by UL for use in select GE, ITE/Siemens and Crouse-Hinds panels (refer to Pub. No. 5655B65H01 for additional details).	Plug on to the loadcenter bus; see instructions.	120/240 Vac	Single	60	150 V L1–N, 300 V L–L	600 V L1–N, 1000 V L–L	3 kA	10 kA	18 kA
										
<b>CHSA</b>	<b>CHSA</b> UL and CSA for use in a Type CH loadcenter.	Plug on to the loadcenter bus; see instructions.	120/240 Vac	Single	60	150 V L1–N, 300 V L–L	600 V L1–N, 1000 V L–L	3 kA	10 kA	18 kA
										
<b>BRSURGECSA</b>	<b>BRSURGECSA</b> CSA for use in an Eaton Type BR loadcenter.	Plug on to the loadcenter bus; see instructions.	120/240 Vac	Single	60	150 V L1–N, 300 V L–L	600 V L1–N, 1000 V L–L	3 kA	10 kA	18 kA
										
<b>CHQSA</b>	<b>CHQSA</b> This device is UL classified to be used in place of Square D Type QO surge arresters (refer to Pub-23974).	Plug on to the loadcenter bus; see instructions.	120/240 Vac	Single	60	150 V L1–N, 300 V L–L	600 V L1–N, 1000 V L–L	3 kA	10 kA	18 kA
										

##### Notes

- ① MCOV: Maximum Continuous Operating Voltage that may be applied to the device per mode.
- ② VPR: Voltage Protection Rating is the measured limiting voltage after a surge event.
- ③ I<sub>n</sub>: Nominal Discharge Current is the current that the device can withstand for 15 impulses.
- ④ SCCR: The amount of current the product can withstand under short-circuit conditions.
- ⑤ Surge Current Capacity: The maximum one-time surge current rating per phase.

For warranty details, go to [www.eaton.com/surgetrap](http://www.eaton.com/surgetrap).

# Residential Backup Transfer Switch Solutions

## Transfer Switch Solutions



### 3.1 Automatic Transfer Switches

Product Description	V1-T3-2
Application Description	V1-T3-2
Standards and Certifications	V1-T3-3
Catalog Number Selection	V1-T3-3
Product Selection	V1-T3-4
Standard Automatic Transfer Switches	V1-T3-4
Green Automatic Transfer Switches— Featuring Active Load Management Technology	V1-T3-4
ATS Ready Loadcenter	V1-T3-5
Dimensions	V1-T3-6

### 3.2 Manual Transfer Switches

Product Description	V1-T3-7
Application Description	V1-T3-7
Features, Benefits and Functions	V1-T3-7
Standards and Certifications	V1-T3-8
Reference Information	V1-T3-8
Product Selection	V1-T3-9
Manual Transfer Switches and Generator Panels Selection	V1-T3-9
Power Inlet Boxes	V1-T3-9
Technical Data and Specifications	V1-T3-10
Dimensions	V1-T3-10

# 3.1

## Residential Backup Transfer Switch Solutions

### Automatic Transfer Switches

3

#### Residential Automatic Transfer Switches



#### Product Description

##### 50, 100, 150, 200 and 400 A Fully Automatic

All Eaton automatic transfer switches (ATS) monitor utility and generator voltages and will automatically connect to the appropriate source of power. Eaton offers two types of automatic transfer switches to suit your personal backup power needs—the standard ATS EGSX series with load shedding capabilities and the Green ATS EGSU series that provides a truly active load management solution.

##### Green Line of Automatic Transfer Switches

With the rising cost of commodities and fuel in today’s economy, consumers are concerned with maximizing the value of their purchases.

Electrical loads are now intelligently managed with Eaton’s Green Line of automatic transfer switches. The active load management inside each Green ATS allows the consumer to use 100% of the power rated output of the generator and/or use a smaller generator, reducing upfront installation costs and saving on ongoing fuel consumption costs.

As a part of Eaton’s commitment to quality, every Green ATS, at no extra cost, will ship with a CHSPT2ULTRA whole surge protector, which will help prevent potential damage to valued electronics caused by power surges in the utility line.

#### Contents

<i>Description</i>	<i>Page</i>
Automatic Transfer Switches	
Standards and Certifications . . . . .	<b>V1-T3-3</b>
Catalog Number Selection . . . . .	<b>V1-T3-3</b>
Product Selection . . . . .	<b>V1-T3-4</b>
ATS Ready Loadcenter . . . . .	<b>V1-T3-5</b>
Dimensions . . . . .	<b>V1-T3-6</b>

#### Application Description

##### 50, 100, 150, 200 and 400 A Switches

100, 200 and 400 A switches are capable of “whole house” power transfer in residential/ small business applications.

##### 50 A—Indoor Installation—Selected Load Pre-Wired

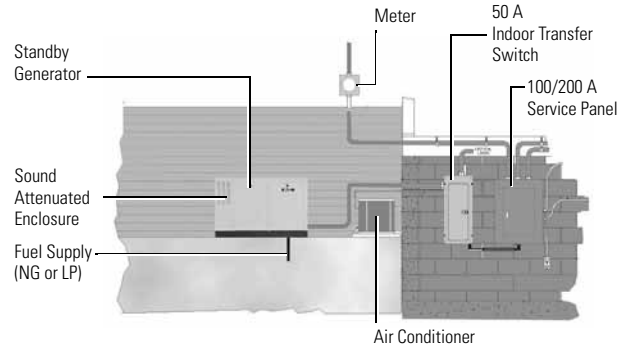

##### 100/200 A—Outdoor Installation—Whole House Pre-Wired

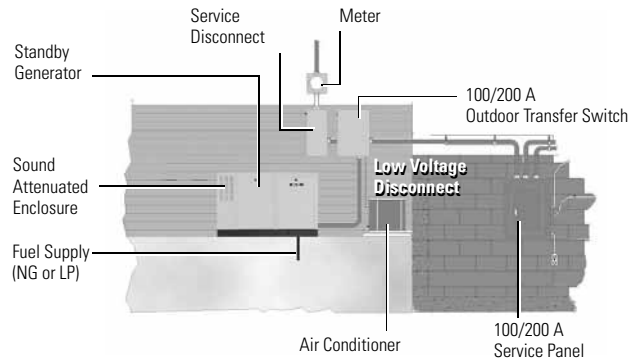

### Standards and Certifications

- UL 1008 listed
- UL 67 listed
- CSA



### Catalog Number Selection

#### Standard Automatic Transfer Switches—EGSX Series

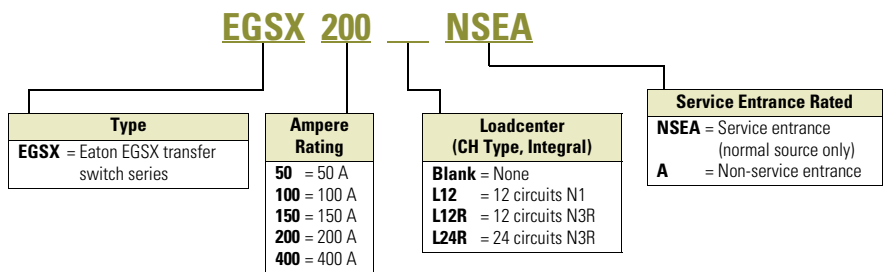

#### Green Automatic Transfer Switches—EGSU Series

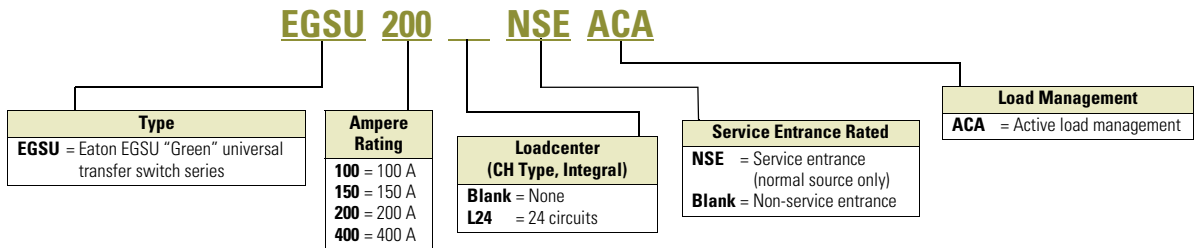

# 3.1

## Residential Backup Transfer Switch Solutions

### Automatic Transfer Switches

#### Product Selection

EGSX50L12R

#### Standard Automatic Transfer Switches ①



Ampere Rating	Voltage	Service Entrance Rated	No. of Load Shed Contacts	Contactors Wire Size Range(s)	No. of Cables per Phase	Withstand Current (rms) at 240 Vac	No. of Circuits Included ②	Frequency (Hz)	Enclosure Type	Most Common Generator Sizes (kW) ③	Catalog Number
50	120/240	No	2	#14–#6	1	5000	12	50/60	NEMA 1 (indoor)	9, 11	EGSX50L12
50	120/240	No	2	#14–#6	1	5000	12	50/60	NEMA 3R (outdoor)	9, 11	EGSX50L12R
100	120/240	No	2	#14–#2/0	1	10,000	—	50/60	NEMA 3R (outdoor)	9, 11, 16	EGSX100A
100	120/240	Yes	2	#14–#2/0	1	10,000	—	50/60	NEMA 3R (outdoor)	9, 11, 16	EGSX100NSEA
100	120/240	No	2	#14–#2/0	1	10,000	24	50/60	NEMA 3R (outdoor)	9, 11, 16	EGSX100L24RA
150	120/240	Yes	2	#4–300 kcmil	1	10,000	—	50/60	NEMA 3R (outdoor)	16, 20, 22	EGSX150NSEA
200	120/240	No	2	#4–300 kcmil	1	10,000	—	50/60	NEMA 3R (outdoor)	16, 20, 22	EGSX200A
200	120/240	Yes	2	#4–300 kcmil	1	10,000	—	50/60	NEMA 3R (outdoor)	16, 20, 22	EGSX200NSEA
400	120/240	Yes	2	750 kcmil–2 300 kcmil–1/0	1/2	35,000	—	50/60	NEMA 3R (outdoor)	>22	EGSX400NSEA

EGSU200NSEACA

#### Green Automatic Transfer Switches ④—Featuring Active Load Management Technology



Ampere Rating	Voltage	Service Entrance Rated	Contactors Wire Size Range(s)	No. of Cables per Phase	Withstand Current (rms) at 240 Vac	No. of Circuits Included ②	Frequency (Hz)	Enclosure Type	Most Common Generator Sizes (kW) ③	Catalog Number ⑤
100	120/240	No	#14–#2/0	1	10,000	—	50/60	NEMA 3R (outdoor)	9, 11, 16	EGSU100ACA
100	120/240	Yes	#14–#2/0	1	10,000	—	50/60	NEMA 3R (outdoor)	9, 11, 16	EGSU100NSEACA
100	120/240	No	#14–#2/0	1	10,000	24	50/60	NEMA 3R (outdoor)	9, 11, 16	EGSU100L24RACA
150	120/240	Yes	#4–300 kcmil	1	10,000	—	50/60	NEMA 3R (outdoor)	16, 20, 22	EGSU150NSEACA
200	120/240	No	#4–300 kcmil	1	10,000	—	50/60	NEMA 3R (outdoor)	16, 20, 22	EGSU200ACA
200	120/240	Yes	#4–300 kcmil	1	10,000	—	50/60	NEMA 3R (outdoor)	16, 20, 22	EGSU200NSEACA
400	120/240	Yes	750 kcmil–2 300 kcmil–1/0	1/2	35,000	—	50/60	NEMA 3R (outdoor)	>22	EGSU400NSEACA

#### Notes

- ① Standard ATS “EGSX” Series compatible with Generac generators only.
- ② Uses CH type circuit breakers.
- ③ For reference only. Generator size must be determined with proper/actual load calculations.
- ④ UNIVERSAL ATS: compatible with any single-phase, 120/240 V generator brand.
- ⑤ Whole house surge Cat. No. CHSPT2ULTRA included in every Green ATS “EGSU” Series.

### ATS Ready Loadcenter

From the far-reaching power failures brought on by hurricanes and snow/ice storms, to the increasing power outage concerns and an aging electrical infrastructure, backup power is more important than ever. Eaton's ATS Ready loadcenter addresses future backup power needs by enabling a fast, efficient installation of an automatic transfer switch kit to convert from utility power to generator power.

The ATS Ready loadcenter gives homebuilders and electrical contractors the flexibility to install a generator ready system or to install a loadcenter and easily add an ATS in the future. Backup power had never been that versatile before.

### ATS Ready Loadcenter Features

- CH Premium Type 200 A single-phase MCB 36-circuit loadcenter
- 50 A ATS "EGSX" type kit for factory or field installation (compatible with Eaton generators only)
- 22 circuits for non-essential loads and 14 circuits for essential backup power loads
- Versatile, space-saving design
- For use with 9 or 11 kW air-cooled generators
- CH cover included
- Lifetime warranty on CH loadcenter and breakers
- NEMA 1 design
- UL Listed

### ATS Ready Loadcenter

	Description	Catalog Number
 <p><b>CH36B200EGP</b></p>	<p>ATS Ready loadcenter Kit CHEGSX50KIT must be ordered separately Loadcenter only. Includes provision for ATS kit</p>	<p><b>CH36B200EGP</b></p>
 <p><b>CHEGSX50KIT</b></p>	<p>ATS "EGSX" kit for ATS Ready loadcenter Field-installable automatic transfer switch kit ATS Ready loadcenter CH36B200EGP must be ordered separately Intuitive, easy installation Compatible with Generac generators only</p>	<p><b>CHEGSX50KIT</b></p>
 <p><b>CH36B200EGPK</b></p>	<p>ATS Ready LC with factory-installed ATS kit Factory assembled Compatible with Generac generator only. Generator needed to complete backup power system</p>	<p><b>CH36B200EGPK</b></p>



# 3.1

## Residential Backup Transfer Switch Solutions

### Automatic Transfer Switches

#### Dimensions

Approximate Dimensions in Inches (mm)

#### Automatic Transfer Switches

3

Catalog Number	Width	Height	Depth	Weight Lbs (kg)
<b>EGSX50L12</b>	14.25 (362.0)	21.00 (533.4)	4.00 (101.6)	25 (11.33)
<b>EGSX50L12R</b>	14.25 (362.0)	21.00 (533.4)	6.00 (152.4)	29 (13.15)
<b>EGSX100A</b>	14.46 (367.3)	16.87 (428.5)	5.32 (135.1)	25 (11.33)
<b>EGSX100NSEA</b>	14.46 (367.3)	16.87 (428.5)	5.32 (135.1)	28 (12.70)
<b>EGSX100L24RA</b>	14.46 (367.3)	29.33 (744.0)	5.32 (135.1)	38 (17.24)
<b>EGSX200A</b>	14.46 (367.3)	25.08 (637.0)	5.25 (133.4)	35 (15.87)
<b>EGSX150NSEA</b>	14.46 (367.3)	29.20 (741.7)	5.32 (135.1)	45 (20.41)
<b>EGSX200NSEA</b>	14.46 (367.3)	29.20 (741.7)	5.32 (135.1)	45 (20.41)
<b>EGSU100L24RACA</b>	14.46 (367.3)	29.33 (745.0)	5.32 (135.1)	38 (17.24)
<b>EGSU100ACA</b>	14.46 (367.3)	16.87 (428.5)	5.32 (135.1)	25 (11.33)
<b>EGSU100NSEACA</b>	14.46 (367.3)	16.87 (428.5)	5.32 (135.1)	28 (12.70)
<b>EGSU150NSEACA</b>	14.46 (367.3)	29.20 (741.7)	5.32 (135.1)	45 (20.41)
<b>EGSU200ACA</b>	14.46 (367.3)	25.08 (637.0)	5.25 (133.4)	35 (15.88)
<b>EGSU200NSEACA</b>	14.46 (367.3)	29.20 (741.7)	5.32 (135.1)	45 (20.41)
<b>EGSU400NSEACA</b>	23.14 (587.8)	35.55 (903.0)	10.00 (254.0)	120 (54.43)
<b>CH36B200EGPK</b>	14.31 (363.5)	47.50 (1206.5)	3.88 (98.6)	40 (18.14)

All Panels are Manufactured in the USA and Meet UL 1008



### Contents

<i>Description</i>	<i>Page</i>
Manual Transfer Switches	
Standards and Certifications . . . . .	<b>V1-T3-8</b>
Reference Information . . . . .	<b>V1-T3-8</b>
Product Selection . . . . .	<b>V1-T3-9</b>
Technical Data and Specifications . . . . .	<b>V1-T3-10</b>
Dimensions . . . . .	<b>V1-T3-10</b>



### Product Description

A manual transfer switch is a device that is mounted next to the loadcenter (distribution panel) in the home or small business. The manual transfer switch is used in conjunction with a portable backup power generator and serves the purpose of turning selected circuits on and off during a power outage. The transfer switch panel allows the owner to start up a generator to restore power to critical circuits when utility power is not available.

The owner designates which circuits are critical, such as the refrigerator and certain lights. Sometimes called emergency power panels or emergency generator panels, manual transfer switch panels provide the homeowner or small business owner with a safe and easy way to continue using electrical appliances when the utility power is unavailable temporarily.

### Application Description

Manual transfer switches are most often used in residential, agricultural and light commercial applications. Comfort and safety are key concerns of many homeowners who are dependent on an uninterrupted supply of electricity.

The increase in our dependence on power is due in part to the popularity of home offices and in-home health care. Various heavily populated regions of the United States experience periodic power outages due to extreme weather conditions, such as ice and snowstorms, heat waves, tornadoes or hurricanes. These regions that include the Pacific Northwest, Atlantic Coast and the Gulf Coast are the strongest markets for portable generators and manual transfer switches.

### Features, Benefits and Functions

Eaton offers two manual transfer switch backup power solutions:

- Manual transfer switches
- Generator panels

#### Manual Transfer Switches

- Panel and components sold separately
- Hardwired generator connection
- Ideal for new construction/larger loads
- Sturdy copper bus construction
- Uses CH and CHT circuit breaker types (sold separately)
- Mechanically interlocked main disconnects to prevent paralleling of normal and emergency power source
- Indoor and outdoor designs available



**Manual Transfer Switch  
Indoor Design**



**Manual Transfer Switch  
Indoor/Outdoor Design**

#### Generator Panels

- Mechanically interlocked main disconnects prevent paralleling of normal and emergency power source
- Panel and components sold separately
- Integral plug-in generator connection (power inlet box)
- All circuit breakers are included—switching duty rated
- Includes dual wattmeters for load balancing
- Indoor and outdoor designs available



**Generator Panel  
Indoor Design**



**Generator Panel  
Outdoor Design**

#### Standards and Certifications

- UL 67 listed
- UL 1008 listed



#### Reference Information

##### Cross-Reference

Watts	Number of Circuits	Ampere Rating	Catalog Number Eaton	Gen/Tran <sup>①</sup>	EmerGen <sup>①</sup>	Square D	Generac <sup>②</sup>
5000	4–8	30	<b>CH48GEN3060R</b>	—	—	QQ48M30DSGP	—
15,000	8–16	60	<b>CH816GEN6060</b>	—	—	QQ48M60DSGP	—
5000	6	20	<b>CH6EGEN2060</b>	20216	6-5000	—	—
5000	6	20	<b>CH6EGEN2060R</b>	R20216	6-5000 + RTE657	—	—
5000	6	20	<b>CH6EGEN2060SU</b>	—	—	—	—
5000	6	20	<b>CH6EGEN2060RSU</b>	—	—	—	—
7500	10	30	<b>CH10EGEN3060</b>	302110-20	10-7500	—	—
7500	10	30	<b>CH10EGEN3060R</b>	R30211-20	10-7500 + RTE1075	—	—
7500	10	30	<b>CH10EGEN3060SUR</b>	—	—	—	—
7500	10	30	<b>CH10EGEN3060RSU</b>	—	—	—	—
7500	10	30	<b>CH10GEN5030SN</b>	—	—	—	—
7500	10	30	<b>CH10GEN5030RSN</b>	—	—	—	—
12,000	10	50	<b>CH10GEN5050SN</b>	—	—	—	—
12,000	10	50	<b>CH10GEN5050RSN</b>	—	—	—	—

##### Notes

- <sup>①</sup> Gen/Trans device is not supplied with a power cord.
- <sup>②</sup> Generac device is 7200 maximum watts on six-circuit device and 12,000 maximum watts on 10-circuit device.

## Product Selection



## Manual Transfer Switches and Generator Panels Selection

Enclosure Type	Watts	Number of Circuits	Ampere Rating	Main/Emergency Ampere Rating	Feeder Breakers	Included Accessories	Catalog Number
<b>Standard Manual Transfer Switch</b>							
NEMA 3R	5000	4–8	30	Provision	Provision	None	<b>CH48GEN3060R</b>
NEMA 1	10,000	8–16	60	Provision	Provision	None	<b>CH816GEN6060</b>
<b>Generator Panel</b>							
NEMA 1	5000	6	20	60/20	5–1P151–1P20	None	<b>CH6EGEN2060</b>
NEMA 3R	5000	6	20	60/20	5–1P151–1P20	None	<b>CH6EGEN2060R</b>
NEMA 1	5000	6	20	60/20	5–1P151–1P20	Two-pole surge protector	<b>CH6EGEN2060SUR</b>
NEMA 3R	5000	6	20	60/20	5–1P151–1P20	Two-pole surge protector	<b>CH6EGEN2060RSU</b>
NEMA 1	7500	10	30	60/30	6–1P152–1P2012P30	None	<b>CH10EGEN3060</b>
NEMA 3R	7500	10	30	60/30	6–1P152–1P2012P30	None	<b>CH10EGEN3060R</b>
NEMA 1	7500	10	30	60/30	7–1P152–1P2012P30	Two-pole surge protector	<b>CH10EGEN3060SUR</b>
NEMA 3R	7500	10	30	60/30	7–1P152–1P2012P30	Two-pole surge protector	<b>CH10EGEN3060RSU</b>
<b>Switched Neutral Manual Transfer Switch</b>							
NEMA 1	7500	10	30	50/30	6–1P15, 2–1P20, 1–2P30	None	<b>CH10GEN5030SN</b>
NEMA 3R	7500	10	30	50/30	6–1P15, 2–1P20, 1–2P30	None	<b>CH10GEN5030RSN</b>
NEMA 1	12,000	10	50	50/50	6–1P15, 2–1P20, 1–2P30	None	<b>CH10GEN5050SN</b>
NEMA 3R	12,000	10	50	50/50	6–1P15, 2–1P20, 1–2P30	None	<b>CH10GEN5050RSN</b>



## Power Inlet Boxes

Description	Ampere Rating	Voltage	Catalog Number
Flush flange kit (for use with generator panel only)	—	120/240 V	<b>CHEGENFKIT</b>
Power inlet box	20	120/240 V	<b>EGSPIB20</b>
Power inlet box	30	120/240 V	<b>EGSPIB30</b>
Power inlet box	50	120/240 V	<b>EGSPIB50</b>

## Warranty

## Manual Transfer Switch

- 15-year loadcenter warranty
- Lifetime branch breaker warranty

## Generator Panel

- 15-year loadcenter warranty
- Lifetime branch breaker warranty

# 3.2

## Residential Backup Transfer Switch Solutions

### Manual Transfer Switches

#### Technical Data and Specifications

- 10,000 AIC rating
- Switching devices must be circuit breakers
- Manual transfer switch must be supplied with neutral and ground
- Power inlet box must be connected to a circuit breaker for generator protection

#### Installation Diagrams

##### Manual Transfer Switches—Indoor Installation Diagram

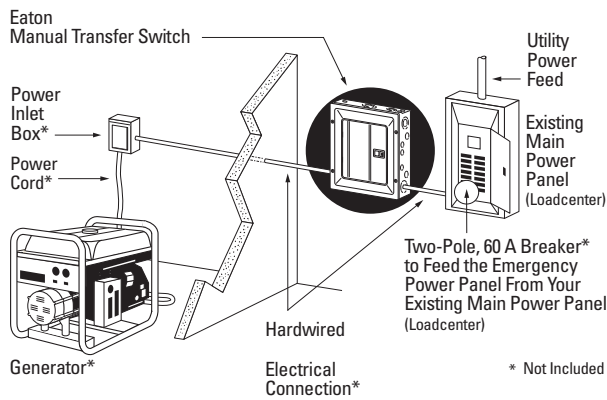

##### Generator Panels—Indoor Installation Diagram

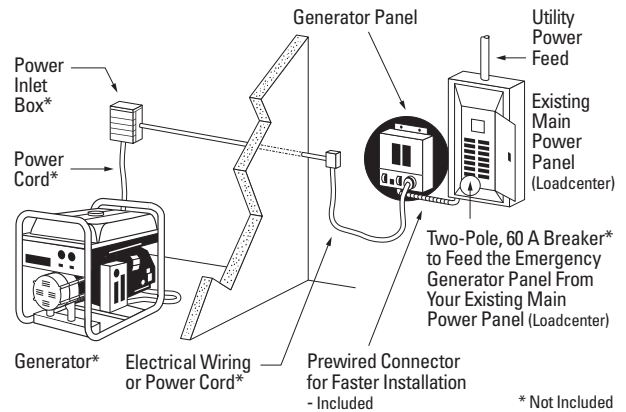

##### Manual Transfer Switches—Outdoor Installation Diagram

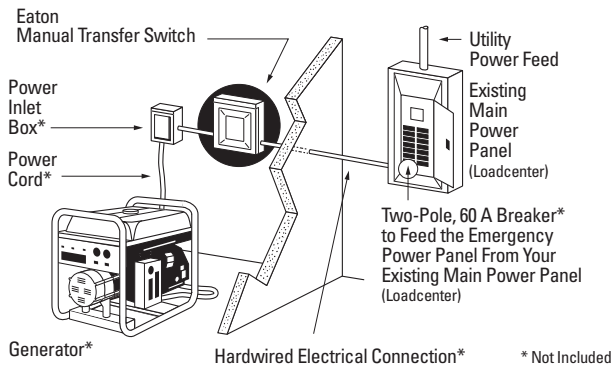

##### Generator Panels—Outdoor Installation Diagram

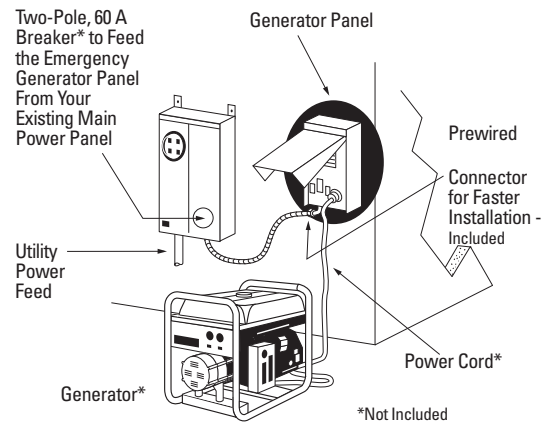

#### Dimensions

Approximate Dimensions in Inches (mm)

##### Manual Transfer Switch

Enclosure Type	Height	Width	Depth	Weight Lbs (kg)	
				6-Circuit	10-Circuit
NEMA 1	16.75 (425.5)	14.31 (363.5)	3.88 (98.5)	24 (11)	26 (12)
NEMA 3R	13.00 (330.2)	11.00 (279.4)	3.56 (90.4)	29 (13)	31 (14)

##### Generator Panel

Enclosure Type	Height	Width	Depth	Weight Lbs (kg)	
				6-Circuit	10-Circuit
NEMA 1	13.23 (336.0)	11.41 (289.8)	4.10 (104.1)	24 (11)	26 (12)
NEMA 3R	17.12 (434.8)	9.45 (240.0)	7.16 (181.9)	29 (13)	31 (14)

Group Metering and Meter Breaker Family



<b>4.1</b>	<b>Meter Sockets</b>	
	Single Meter Sockets . . . . .	<b>V1-T4-2</b>
	Commercial Lever Bypass Sockets . . . . .	<b>V1-T4-10</b>
	Multiple Position Horizontal Ganged Sockets . . . . .	<b>V1-T4-17</b>
	Instrument Rated Sockets . . . . .	<b>V1-T4-23</b>
	Residential Pedestals . . . . .	<b>V1-T4-28</b>
	Meter Socket Accessories . . . . .	<b>V1-T4-30</b>
<b>4.2</b>	<b>Meter Breakers</b>	
	Residential Meter Breakers . . . . .	<b>V1-T4-35</b>
	Non-EUSERC Combination Service Entrance Devices 100–200 A Styles . . . . .	<b>V1-T4-37</b>
	EUSERC Required Service Entrance Devices 100–225 A. . . . .	<b>V1-T4-41</b>
	West Coast All-In-One Design . . . . .	<b>V1-T4-44</b>
	House Panels . . . . .	<b>V1-T4-48</b>
	Aluminum Meter Breakers . . . . .	<b>V1-T4-53</b>
	CH Style Renovation Solutions. . . . .	<b>V1-T4-54</b>
	Commercial Safety Sockets . . . . .	<b>V1-T4-55</b>
	Meter Breakers Accessories . . . . .	<b>V1-T4-58</b>
<b>4.3</b>	<b>Group Metering</b>	
	Systems for Residential and Commercial Applications . . . . .	<b>V1-T4-68</b>
	Meter Packs . . . . .	<b>V1-T4-76</b>
	Meter Packs—Tenant Circuit Breakers . . . . .	<b>V1-T4-88</b>
	Main Service Modules . . . . .	<b>V1-T4-89</b>
	Residential Meter Stacks . . . . .	<b>V1-T4-108</b>
	Commercial Meter Stack Modules . . . . .	<b>V1-T4-123</b>
	Phase Balanced Stack . . . . .	<b>V1-T4-132</b>
	Group Metering Inline Current Transformer Cabinets . . . . .	<b>V1-T4-133</b>
	Surge Metering . . . . .	<b>V1-T4-134</b>
	Group Metering Accessories . . . . .	<b>V1-T4-135</b>



Single Meter Sockets



### Contents

<i>Description</i>	<i>Page</i>
Single Meter Sockets	
Features and Benefits . . . . .	<b>V1-T4-3</b>
Catalog Number Selection . . . . .	<b>V1-T4-3</b>
Product Selection . . . . .	<b>V1-T4-4</b>
Dimensions . . . . .	<b>V1-T4-8</b>
Commercial Lever Bypass Sockets . . . . .	<b>V1-T4-10</b>
Multiple Position Horizontal Ganged Sockets . . . . .	<b>V1-T4-17</b>
Instrument Rated Sockets . . . . .	<b>V1-T4-23</b>
Residential Pedestals . . . . .	<b>V1-T4-28</b>
Meter Socket Accessories . . . . .	<b>V1-T4-30</b>

### Single Meter Sockets

#### Product Description

**Single-Phase Three-Wire and Three-Phase Four-Wire 600 Vac Single Meter Sockets**

All Eaton sockets are rated 600 Vac maximum and either 100, 200 or 320 A continuous. All have a minimum short-circuit rating of 10,000 rms symmetrical amperes (watthour meter is not included in rating).

All single meter sockets are UL labeled and are supplied in surface mounted outdoor enclosures. Confirm local utility acceptance prior to order entry.

Features and Benefits

Single Meter Sockets

Features	Benefits
Block assembly base exceeds 400 in-lbs of torque	Provides durability under the most extreme installation circumstances
One-piece, die-run enclosure	Eliminates tampering and extends product life
High visibility Eaton name embossed on cover	Company identity and brand preference
Knockouts are installer friendly	Labor savings, less time needed for removing knockouts
Oversized 7/8-inch diameter, heavy-duty, steel lug screws	Stronger connection component facilitates a reliable wire termination
Slide-nuts are captive	Allow for ease in installation of conductors and eliminates lost components
Horn bypass kit is field installable by changing out slide nut	Less inventory required and field modifications are simple
Integral triplex or quadplex ground extruded in neutral lug	One piece for terminating incoming/outgoing neutral conductors, which increases integrity of connections
100% plated bridge with 4-point mounting	Zinc chromate plated to provide superior corrosion resistance
kAIC rating	Tested and UL listed up to 200 kAIC rating with specified overcurrent protection devices
Provides a complete Eaton residential solution	Adding meter sockets to the already existing (loadcenter, surge, breakers, generators and AC disconnect) product lines that we already provide, makes Eaton a one-stop shop for our customers residential and light commercial needs
Copper-plated alloy jaws with reinforcing spring	Steel reinforcing springs used in all socket jaws to maintain electrical connections

Catalog Number Selection

Single Meter Sockets RS Group

**UT RS 2 0 2 B CH**

**Note:** The "U" prefix is always used first followed by other prefixes required in alphabetical order.

Standard Prefixes	
<b>A</b>	= Aluminum enclosure
<b>B</b>	= Barrel lock provision, for an exposed INNER-TITE® or Brooks barrel lock; unit includes an internal lock receiver bracket
<b>F</b>	= Barrel Lock with guard provision, for a lock guard INNER-TITE or Brooks barrel lock; unit includes an internal lock receiver bracket
<b>G</b>	= Grounded fifth terminal (9 o'clock position)
<b>H</b>	= Horn bypass
<b>I</b>	= Inhibitor installed in wire connectors
<b>M</b>	= Temporary meter cover (waxed cardboard)
<b>N</b>	= No sealing ring (applies only to ring style sockets)
<b>R</b>	= Ring style socket
<b>S</b>	= Aluminum screw type sealing ring (applies only to ring style sockets)
<b>T</b>	= Grounding connector (#14-#2 Cu) for triplex ground
<b>TT</b>	= Two grounding connectors (#14-#2 Cu) for quadplex ground
<b>U</b>	= UL Underwriters Laboratories label
<b>Z</b>	= 5/16-inch hex head connector screw in place of slotted (100 A only)

Product Group	
<b>RS</b>	= Residential service, single position
<b>2R-6R</b>	= Residential service, multiple position
<b>2H-6H</b>	= Commercial or residential service, multiple position
<b>H</b>	= Commercial or residential service, single position

Standard Suffixes	
<b>A</b>	= Solid top
<b>B</b>	= Small hub opening
<b>C</b>	= Small hub closing plate mounted
<b>L</b>	= 1.25-inch (31.8 mm) hub mounted
<b>M</b>	= 1.50-inch (38.1 mm) hub mounted
<b>N</b>	= 2.00-inch (50.8 mm) hub mounted
<b>P</b>	= 2.50-inch (63.5 mm) hub mounted
<b>T</b>	= Large hub opening hub
<b>U</b>	= Large hub cover plate hub mounted
<b>V</b>	= 2.50-inch (63.5 mm) large hub mounted
<b>Q</b>	= 3.00-inch (76.2 mm) large hub mounted
<b>R</b>	= 3.50-inch (88.9 mm) large hub mounted
<b>S</b>	= 4.00-inch (101.6 mm) large hub mounted
<b>Z</b>	= Large to small hub adapter mounted

Maximum Conductor (Line and Load)	
<b>0</b>	= 0.38-inch stud connectors
<b>1</b>	= #2/0 connectors
<b>2</b>	= #250 kcmil connectors
<b>3</b>	= #350 kcmil connectors

Service Design	
<b>0</b>	= Overhead
<b>1</b>	= Combination overhead/underground
<b>2</b>	= Underground, side wired
<b>3</b>	= Combination overhead/underground, side wired

Ampere Rating	
<b>1</b>	= 100 A
<b>2</b>	= 200 A
<b>5</b>	= 150 A



#### Product Selection

URS212ACH

#### Residential Ringless Type Cover



4

Ampere Rating	Jaws	Service	Bypass	Connections Line	Load	Opening, Hub or Closure Plate	Catalog Number
200	4	UG	—	3/8-inch studs	3/8-inch studs	Solid top	UTRS240ACH
200	4	OH/UG	—	3/8-inch studs	3/8-inch studs	3-5/16 hub cover plate	UTRS2303CCH
200	4	UG	—	#8–350 kcmil	#8–350 kcmil	Solid top	UTRS223ACH
200	4	UG	—	3/8-inch studs	3/8-inch studs	Solid top	UTRS220ACH
200	4	OH/UG	—	#8–350 kcmil	#8–350 kcmil	3-5/16 cover plate	UTRS213CFLCH
200	4	OH/UG	—	#8–350 kcmil	#8–350 kcmil	3-5/16 hub cover plate	UTRS213CEPCH
200	4	OH/UG	—	#6–350 kcmil	#6–350 kcmil	3-5/16 hub cover plate	UGTRS213CE
200	4	OH/UG	—	#6–350 kcmil	#6–350 kcmil	3-5/16 hub cover plate	UTRS213CE
200	4	OH/UG	—	#6–350 kcmil	#6–350 kcmil	3-5/16 hub opening	UATRS213BCH
200	4	OH/UG	—	#6–350 kcmil	#6–350 kcmil	3-5/16 hub opening	URS213BCH
200	4	OH/UG	—	#6–350 kcmil	#6–350 kcmil	3-5/16 hub opening	UTRS213BE
200	4	UG	—	#8–350 kcmil	#8–350 kcmil	Solid top	UTRS213AFLCH
200	4	UG	—	#8–350 kcmil	#8–350 kcmil	Solid top	UTRS213ACH
200	4	OH/UG	Horn	#8–350 kcmil	#8–350 kcmil	3-5/16 hub opening	UTRS2138BCH
200	4	OH/UG	—	#8–250 kcmil	#8–250 kcmil	Solid top	UTRS212ACH
200	4	OH/UG	—	#8–250 kcmil	#8–250 kcmil	3-5/16 cover plate	UTRS212CCH
200	4	OH/UG	—	#8–250 kcmil	#8–250 kcmil	3-5/16 cover plate	UTRS212CFLCH
200	4	OH/UG	—	#8–250 kcmil	#8–250 kcmil	3-5/16 hub opening	UTRS212BCH
200	4	OH	—	#8–250 kcmil	#8–250 kcmil	2-inch bolt-on hub	UTRS202NCH
200	4	OH	—	#8–250 kcmil	#8–250 kcmil	Small hub opening	UATRS202BFLCH <sup>①</sup>
200	4	OH/UG	—	#8–250 kcmil	#8–250 kcmil	3-5/16 cover plate	UTRS232CCH
200	4	OH	—	#8–2/0 cu/al	#8–2/0 cu/al	3-5/16 hub opening	UTRS202BCH
200	4	OH/UG	—	#8–250 kcmil	#8–250 kcmil	Solid top	URS212ACH
200	4	OH	—	#8–250 kcmil	#8–250 kcmil	2-inch bolt-on hub	URS202NCH
200	5	OH	Horn	#8–250 kcmil	#8–250 kcmil	3-5/16 hub opening	URS202BDQCH
200	4	OH/UG	Horn	#8–350 kcmil	#8–350 kcmil	3-5/16 hub cover plate	UFHTRS213CCH <sup>②</sup>
200	4	OH/UG	Horn	#8–350 kcmil	#8–350 kcmil	3-5/16 hub opening	UHTRS213BCH
200	4	OH/UG	Horn	#8–350 kcmil	#8–350 kcmil	3-5/16 hub cover plate	UHTRS213CCH
200	4	OH	Horn	#8–250 kcmil	#8–250 kcmil	3-5/16 hub opening	UHTRS202BCH
200	5	OH/UG	Horn	#8–350 kcmil	#8–350 kcmil	3-5/16 hub cover plate	UHTRS233CCH
200	4	UG	Horn	#8–350 kcmil	#8–350 kcmil	Solid top	UHTRS223ARHCH
200	4	UG	Horn	#8–350 kcmil	#8–350 kcmil	Solid top	UFHTRS223ACH
200	5	UG	Horn	#8–350 kcmil	#8–350 kcmil	Solid top	UGHTRS223ACH
200	4	UG	Horn	#8–350 kcmil	#8–350 kcmil	Solid top	UHTRS223ACH
200	4	UG	Horn	#8–350 kcmil	#8–350 kcmil	Solid top	UHTRS223ACH
200	4	OH/UG	Horn	#6–350 kcmil	#6–350 kcmil	3-5/16 hub opening	UHTRS213CE
200	4	OH/UG	Horn	#6–350 kcmil	#6–350 kcmil	3-5/16 hub opening	UHTRS213BE
200	4	OH/UG	Horn	#8–350 kcmil	#8–350 kcmil	Solid top	UHTRS213AE
200	4	OH	Horn	#8–350 kcmil	#8–350 kcmil	3-5/16 hub opening	UHTRS203BCH
200	4	OH	Horn	#8–250 kcmil	#8–250 kcmil	3-5/16 hub opening	UHTRS202BCH
200	4	OH/UG	None	#8–250 kcmil	#8–250 kcmil	2-inch bolt-on hub	URS202NPECCH <sup>③</sup>

**Notes**

- ① Aluminum enclosure.
- ② Barrel lock.
- ③ PEC approved.

For dimensions, see **Pages V1-T4-8 and V1-T4-9.**

Residential Ringless Type Cover, continued

Ampere Rating	Jaws	Service	Bypass	Connections Line	Load	Opening, Hub or Closure Plate	Catalog Number
200	4	OH/UG	Horn	#8-350 kcmil	#8-350 kcmil	Solid top	UHIRS223ACVCH
200	4	OH/UG	Horn	#8-350 kcmil	#8-350 kcmil	3-5/16 hub opening	UHIRS213BCVCH
200	5	OH/UG	—	#6-350 kcmil	#6-350 kcmil	Closure plate	UGTRS213CE
200	5	OH/UG	—	#6-350 kcmil	#6-350 kcmil	Hub opening	UGTRS213BE
200	5	OH/UG	Horn	#6-350 kcmil	#6-350 kcmil	Closure plate	786685217918
200	5	OH/UG	Horn	#6-350 kcmil	#6-350 kcmil	3-5/16 hub opening	UGHTRS213BE
200	5	OH/UG	Horn	#8-250 kcmil	#8-250 kcmil	3-5/16 hub cover plate	UGHRS212CKCCH
200	4	OH	—	#8-250 kcmil	#8-250 kcmil	3-5/16 hub opening	UFTRS202BCH
200	4	OH	Horn	#8-250 kcmil	#8-250 kcmil	3-5/16 hub opening	UFHTRS202BCH
200	4	UG	Horn	#8-350 kcmil	#8-350 kcmil	Solid top	UBHTRS223ARHCH
200	4	UG	Horn	#8-350 kcmil	#8-350 kcmil	Solid top	UBHRS223ACH
200	4	OH	Horn	#8-250 kcmil	#8-250 kcmil	3-5/16 hub cover plate	UBHRS202BCH
200	4	OH/UG	—	#8-350 kcmil	#8-350 kcmil	3-5/16 hub opening	UATRS213CFLCH
200	4	OH/UG	Horn	#8-350 kcmil	#8-350 kcmil	3-5/16 hub cover plate	UAHTRS233CSHCH
200	4	UG	Horn	#8-350 kcmil	#8-350 kcmil	Solid top	UAHTRS223AFLCH
200	4	OH	Horn	#8-250 kcmil	#8-250 kcmil	3-5/16 hub opening	UAHTRS202BFLCH
200	4	OH/UG	—	#8-350 kcmil	#8-350 kcmil	3-5/16 hub closure plate	U92197CCCPLCH
200	4	OH/UG	—	#8-350 kcmil	#8-350 kcmil	3-5/16 hub closure plate	1009928CH
200	4	OH/UG	Horn	#8-250 kcmil	#8-250 kcmil	Solid top	1009874ACH
200	4	UG	—	3/8-inch studs	3/8-inch studs	Solid top	1009046CH
200	4	UG	Horn	#8-350 kcmil	#8-350 kcmil	Solid top	1008941CH
200	4	UG	Horn	#8-350 kcmil	#8-350 kcmil	Solid top	1008940CH
200	4	UG	Horn	#8-350 kcmil	#8-350 kcmil	Solid top	1008827CH
200	4	UG	Horn	#8-350 kcmil	#8-350 kcmil	Solid top	1008819CH
200	4	UG	Horn	#8-350 kcmil	#8-350 kcmil	Solid top	1008717CH
200	4	UG	—	#8-350 kcmil	#8-350 kcmil	Solid top	1008617CH
200	4	OH/UG	Horn	#8-350 kcmil	#8-350 kcmil	3-5/16 hub opening	1007817CH
200	4	OH	Horn	#8-250 kcmil	#8-250 kcmil	3-5/16 hub opening	1007699CH
200	4	OH	Horn	#8-250 kcmil	#8-250 kcmil	3-5/16 hub opening	1007665CH
200	4	UG	Horn	#8-350 kcmil	#8-350 kcmil	Solid top	1007588CH
200	4	OH/UG	—	3/8-inch studs	3/8-inch studs	3-5/16 hub opening	1007448ACH
200	4	UG	Horn	#8-350 kcmil	#8-350 kcmil	Solid top	1004884ARHCH ①
200	4	UG	Horn	#8-350 kcmil	#8-350 kcmil	Solid top	1004884ACH
200	4	OH/UG	—	#8-#250 kcmil	#8-#250 kcmil	3-5/16 hub cover plate	1004710ECH
200	4	OH	—	N/A	N/A	N/A	1004709DCH
200	4	OH	Horn	#8-#250 kcmil	#8-#250 kcmil	2-inch bolt-on hubs	1004455BCH
200	4	OH	Horn	#8-250 kcmil	#8-250 kcmil	3-5/16 hub opening	1004161ACH
200	4	OH/UG	Horn	#8-350 kcmil	#8-350 kcmil	3-5/16 hub opening	1004159ACH
200	4	OH/UG	—	#8-350 kcmil	#8-350 kcmil	Hub closure plate	1008826ACH ②
200	4	OH/UG	Lever	#6-350 kcmil	#6-350 kcmil	Hub closure plate	1006352CCH ②
200	5	OH	Horn	#8-250 kcmil	#8-250 kcmil	3-5/16 hub opening	1003879ACH
200	5	OH/UG	Horn	#8-350 kcmil	#8-350 kcmil	3-5/16 hub opening	1003878ACH

Notes

- ① Right hand incoming.
- ② Austin Energy approved.

For dimensions, see Pages V1-T4-8 and V1-T4-9.

URS101BCH



#### Residential Ringless Type Cover, continued

Ampere Rating	Jaws	Service	Bypass	Connections Line	Load	Opening, Hub or Closure Plate	Catalog Number
150	4	OH/UG	—	#8-2/0 AWG	#8-2/0 AWG	Hub closure plate	1004326DCH <sup>①</sup>
150	4	OH/UG	—	#8-250 kcmil	#8-250 kcmil	Hub opening	UTRS502BCH
150	4	OH	—	#8-250 kcmil	#8-250 kcmil	3-5/16 hub opening	UTRS502BCH
150	4	OH	—	#8-250 kcmil	#8-250 kcmil	3-5/16 hub cover plate	UTRS502CCH
125	4	UG	—	N/A	N/A	N/A	1006385BCH
125	4	OH/UG	—	#8-2/0 cu/al	#8-2/0 cu/al	3-5/16 hub opening	UTRS111BCH
125	4	OH	—	#8-2/0 cu/al	#8-2/0 cu/al	3-5/16 hub opening	UBTRS101BCH
125	4	OH	—	#8-2/0 cu/al	#8-2/0 cu/al	1-1/4-inch bolt-on hub	UTRS101LCH
125	4	OH	—	#8-2/0 cu/al	#8-2/0 cu/al	3-5/16 hub cover plate	UTRS101CE
125	4	OH	—	#8-2/0 cu/al	#8-2/0 cu/al	3-5/16 hub opening	UTRS101BE
125	4	OH	—	#8-2/0	#8-2/0	3-5/16 hub cover plate	URS101CCPLCH
125	4	OH	Horn	cu/al with 1/2-inch hex head wire clamping screw	cu/al with 1/2-inch hex head wire clamping screw	3-5/16 hub cover plate	URS101BDQCH
125	4	OH	—	#8-2/0	#8-2/0	3-5/16 hub opening	URS101BCPLCH
125	4	OH	—	#8-2/0	#8-2/0	3-5/16 hub opening	URS101BCH
125	4	OH	Horn	#8-2/0	#8-2/0	3-5/16 hub opening	UHTRS101BCH
125	4	OH/UG	Horn	#8-250 kcmil	#8-250 kcmil	3-5/16 hub opening	UHTRS111BCH
125	4	OH	Horn	#8-2/0	#8-2/0	1.25-inch hub mounted	UHTRS101LCH
125	4	OH	Horn	#8-2/0	#8-2/0	Closure plate	UHTRS101CE
125	4	OH	Horn	#8-2/0	#8-2/0	3-5/16 hub opening	UHTRS101BE
125	5	OH/UG	—	#8-2/0	#8-2/0	3-5/16 hub cover plate	UGRS10101CKCCH
125	5	OH/UG	—	#8-2/0	#8-2/0	3-5/16 hub cover plate	UGHTRS111CCH
125	5	OH	—	#8-2/0	#8-2/0	3-5/16 hub opening	UGHTRS101BCH
125	4	OH	—	#8-2/0	#8-2/0	3-5/16 hub cover plate	UBHRS101BCH
125	4	OH/UG	—	#8-2/0	#8-2/0	3-5/16 hub cover plate	UATZRS101CFLCH
125	4	OH	—	#8-2/0	#8-2/0	3-5/16 hub cover plate	UATRS101CCH
125	4	OH	—	#8-2/0	#8-2/0	3-5/16 hub opening	1008947CH
125	4	UG	N/A	N/A	N/A	N/A	1005826ACH
125	4	OH	—	#8-2/0	#8-2/0	1-1/4-inch bolt-on hub	1004931BCH
125	4	OH	—	#8-2/0	#8-2/0	3-5/16 hub opening	1004162ACH
125	5	OH	—	#8-2/0	#8-2/0	3-5/16 hub opening	1003880ACH
125	4	OH	—	#8-2/0	#8-2/0	3-5/16 hub opening	UTZRS101BFLCH
125	4	OH	—	#8-2/0	#8-2/0	3-5/16 hub closure plate	UTZRS101CFLCH
125	5	OH	Horn	#8-2/0	#8-2/0	Hub opening	UTRS101CEPSEG <sup>②</sup>
100	4	OH	—	#8-2/0	#8-2/0	3-5/16 hub opening	1009079CH
200	5	OH/UG	Horn	#8-350 kcmil	#8-350 kcmil	Hub closure plate	UTRS213CEPSEG <sup>②</sup>

**Notes**

- ① Austin Energy approved.
- ② PSE&G approved.

For dimensions, see **Pages V1-T4-8 and V1-T4-9.**

Residential Ring Type Cover

Ampere Rating	Jaws	Service	Connections Line	Load	Opening, Hub or Closure Plate	Catalog Number
200	4	UG	#8-350 kcmil	#8-350 kcmil	Solid top	URTRS223ACH
200	4	OH/UG	#8-350 kcmil	#8-350 kcmil	3-5/16 hub cover plate	URRS213CCH
200	4	OH/UG	#8-350 kcmil	#8-350 kcmil	2 inch hub mounted	URTRS213NEUSCH
200	4	OH/UG	#8-350 kcmil	#8-350 kcmil	3-5/16 hub cover plate	URTRS213CEUSCH
200	4	OH/UG	#8-350 kcmil	#8-350 kcmil	3-5/16 hub cover plate	1009424CH
200	4	OH/UG	#8-350 kcmil	#8-350 kcmil	Knockouts	1009449CH
200	4	OH	#8-350 kcmil	#8-350 kcmil	3-5/16 hub opening	URSTRS203BCH
200	4	OH	#8-250 kcmil	#8-250 kcmil	3-5/16 hub cover plate	URS212BCRCH
200	4	OH/UG	#8-250 kcmil	#8-250 kcmil	3-5/16 hub cover plate	URTRS202BCH
200	4	OH	#8-250 kcmil	#8-250 kcmil	3-5/16 hub opening	URTRS213BE
200	4	OH/UG	#6-350 kcmil	#6-350 kcmil	Hub opening	URTRS202BCH
200	4	OH/UG	#6-350 kcmil	#6-350 kcmil	Closure plate	URTRS213CE
200	4	UG	#6-350 kcmil	#6-350 kcmil	3-5/16 hub opening	URTRS213BEUSCH
200	4	OH	#8-250 kcmil	#8-250 kcmil	2-inch hub mounted	URTRS202NEUSCH
200	4	OH	#8-250 kcmil	#8-250 kcmil	3-5/16 hub opening	UNRRS202BEUSCH
200	4	OH/UG	#6-350 kcmil	#6-350 kcmil	Closure plate	UNRRS213CEUSE
200	4	OH	#8-250 kcmil	#8-250 kcmil	Hub opening	UNRRS213BEUSE
200	4	UG	#6-350 kcmil	#6-350 kcmil	Solid top	UNRRS213AEUSE
200	4	OH/UG	#6-250 kcmil	#6-250 kcmil	5x5 hub opening 3-5/16 adapter plate	1009097CH
125	4	OH	#8-2/0 cu/al	#8-2/0 cu/al	3-5/16 hub opening	URS101BCRCH
125	4	OH	#8-2/0 cu/al	#8-2/0 cu/al	1-1/4-inch bolt-on hub	URRS101LCH
125	4	OH	#8-2/0 cu/al	#8-2/0 cu/al	Hub cover plate	URTRS101BE
125	4	OH	#8-2/0 cu/al	#8-2/0 cu/al	Hub cover plate	URTRS101CE
125	4	OH	#8-2/0 cu/al	#8-2/0 cu/al	3-5/16 hub cover plate	UNRRS101BEUSE
125	4	OH	#8-2/0 cu/al	#8-2/0 cu/al	Closure plate	UNRRS101CEUSE
125	4	OH/UG	#8-2/0 cu/al	#8-2/0 cu/al	3-5/16 hub cover plate	UNRRS111BEUSE
125	4	UG	#8-2/0 cu/al	#8-2/0 cu/al	Solid top	UNRRS111AEUSE
125	4	OH	#8-2/0 cu/al	#8-2/0 cu/al	3-5/16 hub opening	URSTRS101BCH

**Note**

For dimensions, see Pages V1-T4-8 and V1-T4-9.

## Dimensions

Approximate Dimensions in Inches (mm)

## Residential Ringless Type Cover

Catalog Number	Height	Width	Depth
UTRS240ACH	18.63 (473.2)	13.00 (330.2)	4.94 (125.5)
UTRS2303CCH	20.00 (508.0)	13.00 (330.2)	4.94 (125.5)
UTRS223ACH	13.00 (330.2)	13.00 (330.2)	4.94 (125.5)
UTRS220ACH	15.13 (384.3)	13.00 (330.2)	4.94 (125.5)
UTRS213CFLCH	15.00 (381.0)	11.00 (279.4)	4.37 (111.0)
UTRS213CEPCH	15.00 (381.0)	11.00 (279.4)	4.37 (111.0)
UGTRS213CE	15.13 (384.3)	11.25 (285.8)	4.50 (114.3)
UTRS213CE	15.13 (384.3)	11.25 (285.8)	4.50 (114.3)
UATRS213BCH	15.13 (384.3)	11.25 (285.8)	4.50 (114.3)
URS213BCH	15.00 (381.0)	11.00 (279.4)	4.36 (110.7)
UTRS213BE	15.13 (384.3)	11.25 (285.8)	4.50 (114.3)
UTRS213AFLCH	15.00 (381.0)	11.00 (279.4)	4.37 (111.0)
UTRS213ACH	15.00 (381.0)	11.00 (279.4)	4.36 (110.7)
UTRS2138BCH	20.00 (508.0)	13.00 (330.2)	4.94 (125.5)
UTRS212ACH	14.00 (355.6)	11.00 (279.4)	4.37 (111.0)
UTRS212CCH	14.00 (355.6)	11.00 (279.4)	4.36 (110.7)
UTRS212CFLCH	14.00 (355.6)	11.00 (279.4)	4.36 (110.7)
UTRS212BCH	14.00 (355.6)	11.00 (279.4)	4.36 (110.7)
UTRS202NCH	14.00 (355.6)	8.00 (203.2)	4.36 (110.7)
UATRS202BFLCH ①	14.00 (355.6)	8.00 (203.2)	4.36 (110.7)
UTRS232CCH	17.12 (434.8)	13.00 (330.2)	4.93 (125.2)
UTRS202BCH	14.00 (355.6)	8.00 (203.2)	4.36 (110.7)
URS212ACH	14.00 (355.6)	11.00 (279.4)	4.38 (111.3)
URS202NCH	14.00 (355.6)	8.00 (203.2)	4.38 (111.3)
URS202BDQCH	14.00 (355.6)	8.00 (203.2)	4.38 (111.3)
UFHTRS213CCH ②	15.00 (381.0)	11.00 (279.4)	4.38 (111.3)
UHTRS213BCH	15.00 (381.0)	11.00 (279.4)	4.38 (111.3)
UHTRS213CCH	15.00 (381.0)	11.00 (279.4)	4.38 (111.3)
UHTRS202BCH	14.00 (355.6)	8.00 (203.2)	4.38 (111.3)
UHTRS233CCH	17.13 (435.1)	13.00 (330.2)	4.94 (125.5)
UHTRS223ARHCH	13.00 (330.2)	13.00 (330.2)	4.94 (125.5)
UFHTRS223ACH	13.00 (330.2)	13.00 (330.2)	4.94 (125.5)
UGHTRS223ACH	13.00 (330.2)	13.00 (330.2)	4.94 (125.5)
UHTRS223ACH	13.00 (330.2)	13.00 (330.2)	4.94 (125.5)
UHTRS213CE	15.00 (381.0)	11.00 (279.4)	4.38 (111.3)
UHTRS213BE	15.00 (381.0)	11.00 (279.4)	4.38 (111.3)
UHTRS213AE	15.00 (381.0)	11.00 (279.4)	4.38 (111.3)
UHTRS203BCH	15.00 (381.0)	8.00 (203.2)	4.38 (111.3)
UHTRS202BCH	14.00 (355.6)	8.00 (203.2)	4.38 (111.3)
UHRS223ACVCH	13.00 (330.2)	13.00 (330.2)	4.94 (125.5)

## Residential Ringless Type Cover, continued

Catalog Number	Height	Width	Depth
UHRS213BCVCH	15.00 (381.0)	11.00 (279.4)	4.38 (111.3)
UGTRS213CE	15.13 (384.3)	11.25 (285.8)	4.50 (114.3)
UGTRS213BE	15.13 (384.3)	11.25 (285.8)	4.50 (114.3)
786685217918	15.13 (384.3)	11.25 (285.8)	4.50 (114.3)
UGHTRS213BE	15.13 (384.3)	11.25 (285.8)	4.50 (114.3)
UGHRS212CKCH	14.00 (355.6)	11.00 (279.4)	4.38 (111.3)
UFTRS202BCH	14.00 (355.6)	8.00 (203.2)	4.38 (111.3)
UFHTRS202BCH	14.00 (355.6)	8.00 (203.2)	4.38 (111.3)
UBHTRS223ARHCH	13.00 (330.2)	13.00 (330.2)	4.94 (125.5)
UBHRS223ACH	13.00 (330.2)	13.00 (330.2)	4.94 (125.5)
UBHRS202BCH	14.00 (355.6)	8.00 (203.2)	4.38 (111.3)
UATRS213CFLCH	15.00 (381.0)	11.00 (279.4)	4.38 (111.3)
UAHTRS233CSHCH	17.13 (435.1)	13.00 (330.2)	4.94 (125.5)
UAHTRS223AFLCH	13.00 (330.2)	13.00 (330.2)	4.94 (125.5)
UAHTRS202BFLCH	14.00 (355.6)	8.00 (203.2)	4.38 (111.3)
U92197CCPLCH	14.13 (358.9)	13.00 (330.2)	4.94 (125.5)
1009928CH	15.00 (381.0)	11.00 (279.4)	4.38 (111.3)
1009874ACH	15.00 (381.0)	13.00 (330.2)	4.94 (125.5)
1009046CH	20.75 (527.1)	9.00 (228.6)	4.94 (125.5)
1008941CH	17.13 (435.1)	13.00 (330.2)	4.94 (125.5)
1008940CH	17.13 (435.1)	13.00 (330.2)	4.94 (125.5)
1008827CH	13.00 (330.2)	13.00 (330.2)	4.94 (125.5)
1008819CH	13.00 (330.2)	13.00 (330.2)	4.94 (125.5)
1008717CH	15.00 (381.0)	13.00 (330.2)	4.94 (125.5)
1008617CH	15.00 (381.0)	13.00 (330.2)	4.94 (125.5)
1007817CH	15.00 (381.0)	11.00 (279.4)	4.38 (111.3)
1007699CH	14.00 (355.6)	8.00 (203.2)	4.38 (111.3)
1007665CH	14.00 (355.6)	8.00 (203.2)	4.38 (111.3)
1007588CH	13.00 (330.2)	13.00 (330.2)	4.94 (125.5)
1007448ACH	19.00 (482.6)	11.00 (279.4)	4.38 (111.3)
1004884ARHCH ③	13.00 (330.2)	13.00 (330.2)	4.93 (125.2)
1004884ACH	13.00 (330.2)	13.00 (330.2)	4.93 (125.2)
1004710ECH	14.00 (355.6)	11.00 (279.4)	4.38 (111.3)
1004709DCH	N/A	N/A	N/A
1004455BCH	15.00 (381.0)	8.00 (203.2)	4.38 (111.3)
1004161ACH	14.00 (355.6)	8.00 (203.2)	4.38 (111.3)
1004159ACH	15.00 (381.0)	11.00 (279.4)	4.38 (111.3)
1003879ACH	15.00 (381.0)	8.00 (203.2)	4.38 (111.3)
1003878ACH	15.00 (381.0)	11.00 (279.4)	4.38 (111.3)
UTRS502BCH	14.00 (355.6)	8.00 (203.2)	4.38 (111.3)

## Notes

- ① Aluminum enclosure.
- ② Barrel lock.
- ③ Right hand incoming.

Approximate Dimensions in Inches (mm)

**Residential Ringless Type Cover, continued**

Catalog Number	Height	Width	Depth
UTRS502BCH	14.00 (355.6)	8.00 (203.2)	4.36 (110.7)
UTRS502CCH	14.00 (355.6)	8.00 (203.2)	4.36 (110.7)
1006385BCH	N/A	N/A	N/A
UTRS111BCH	14.00 (355.6)	11.00 (279.4)	4.36 (110.7)
UBTRS101BCH	10.88 (276.4)	8.00 (203.2)	3.50 (88.9)
UTRS101LCH	10.88 (276.4)	8.00 (203.2)	3.50 (88.9)
UTRS101CE	11.05 (280.7)	8.22 (208.8)	3.61 (91.7)
UTRS101BE	11.05 (280.7)	8.22 (208.8)	3.61 (91.7)
URS101CCPLCH	10.88 (276.4)	8.00 (203.2)	3.50 (88.9)
URS101BDQCH	10.88 (276.4)	8.00 (203.2)	3.50 (88.9)
URS101BCPLCH	10.88 (276.4)	8.00 (203.2)	3.50 (88.9)
URS101BCH	10.88 (276.4)	8.00 (203.2)	3.50 (88.9)
UHTRS101BCH	10.88 (276.4)	8.00 (203.2)	3.50 (88.9)
UHTRS111BCH	14.00 (355.6)	11.00 (279.4)	4.38 (111.3)
UHTRS101LCH	10.88 (276.4)	8.00 (203.2)	3.50 (88.9)
UHTRS101CE	11.05 (280.7)	8.22 (208.8)	3.61 (91.7)
UHTRS101BE	11.05 (280.7)	8.22 (208.8)	3.61 (91.7)
UGRS10101CKCCH	12.00 (304.8)	8.00 (203.2)	3.50 (88.9)
UGHTRS111CCH	14.00 (355.6)	11.00 (279.4)	4.36 (110.7)
UGHTRS101BCH	10.88 (276.4)	8.00 (203.2)	3.50 (88.9)
UBHRS101BCH	10.88 (276.4)	8.00 (203.2)	3.50 (88.9)
UATZRS101CFLCH	10.88 (276.4)	8.00 (203.2)	3.50 (88.9)
UATRS101CCH	10.87 (276.1)	8.00 (203.2)	3.50 (88.9)
1008947CH	10.89 (276.6)	8.00 (203.2)	3.50 (88.9)
1005826ACH	N/A	N/A	N/A
1004931BCH	10.88 (276.4)	8.00 (203.2)	3.50 (88.9)
1004162ACH	10.89 (276.6)	8.00 (203.2)	3.50 (88.9)
1003880ACH	10.89 (276.6)	8.00 (203.2)	3.50 (88.9)
UTZRS101BFLCH	N/A	N/A	N/A
UTZRS101CFLCH	N/A	N/A	N/A
1009079CH	23.75 (603.3)	8.00 (203.2)	3.48 (88.4)

**Residential Ring Type Cover**

Catalog Number	Height	Width	Depth
URTRS223ACH	13.00 (330.2)	13.00 (330.2)	4.93 (125.2)
URRS213CCH	15.00 (381.0)	11.00 (279.4)	4.38 (111.3)
URTRS213NEUSCH	15.00 (381.0)	11.00 (279.4)	4.38 (111.3)
URTRS213CEUSCH	15.00 (381.0)	11.00 (279.4)	4.38 (111.3)
1009424CH	15.00 (381.0)	11.00 (279.4)	4.38 (111.3)
1009449CH	18.31 (465.1)	14.19 (360.4)	5.13 (130.3)
URSTRS203BCH	N/A	N/A	N/A
URS212BCRCH	14.00 (355.6)	8.00 (203.2)	4.38 (111.3)
URTRS202BCH	14.00 (355.6)	11.00 (279.4)	4.38 (111.3)
URTRS213BE	14.00 (355.6)	8.00 (203.2)	4.50 (114.3)
URTRS202BCH	15.13 (384.3)	11.25 (285.8)	4.50 (114.3)
URTRS213CE	15.13 (384.3)	11.25 (285.8)	4.50 (114.3)
URTRS213BEUSCH	15.13 (384.3)	11.25 (285.8)	4.50 (114.3)
URTRS202NEUSCH	14.00 (355.6)	8.00 (203.2)	4.38 (111.3)
UNRRS202BEUSCH	14.00 (355.6)	8.00 (203.2)	4.38 (111.3)
UNRRS213CEUSE	15.13 (384.3)	11.25 (285.8)	4.50 (114.3)
UNRRS213BEUSE	15.13 (384.3)	11.25 (285.8)	4.50 (114.3)
UNRRS213AEUSE	15.13 (384.3)	11.25 (285.8)	4.50 (114.3)
1009097CH	19.00 (482.6)	13.00 (330.2)	5.25 (133.4)
URS101BCRCH	10.88 (276.4)	8.00 (203.2)	3.50 (88.9)
URRS101LCH	10.88 (276.4)	8.00 (203.2)	3.50 (88.9)
URTRS101BE	11.00 (279.4)	8.25 (209.6)	3.63 (92.2)
URTRS101CE	11.00 (279.4)	8.25 (209.6)	3.63 (92.2)
UNRRS101BEUSE	10.88 (276.4)	8.00 (203.2)	3.50 (88.9)
UNRRS101CEUSE	10.88 (276.4)	8.00 (203.2)	3.50 (88.9)
UNRRS111BEUSE	14.00 (355.6)	11.00 (279.4)	4.38 (111.3)
URSTRS101BCH	10.88 (276.4)	8.00 (203.2)	3.50 (88.9)

# 4.1

## Metering Products

### Meter Sockets

4

#### Commercial Lever Bypass Sockets



### Contents

#### Description

Description	Page
Single Meter Sockets	V1-T4-2
Commercial Lever Bypass Sockets	
Product Selection	V1-T4-11
Dimensions	V1-T4-15
Multiple Position Horizontal Ganged Sockets	V1-T4-17
Instrument Rated Sockets	V1-T4-23
Residential Pedestals	V1-T4-28
Meter Socket Accessories	V1-T4-30

### Commercial Lever Bypass Sockets

#### Product Description

- Heavy-duty, lever bypass, jaw clamping ringless meter socket design
- 200 A and 320 A styles available
- Single-phase or three-phase
- 4, 5 or 7 terminal available
- 600 Vac maximum rating
- Multiple service design offerings

#### Standards and Certifications

- UL 414 listed and recognized



### Catalog Number Selection

#### Single Meter Sockets H Group

**Note:** The "U" prefix is always used first followed by other prefixes required in alphabetical order.

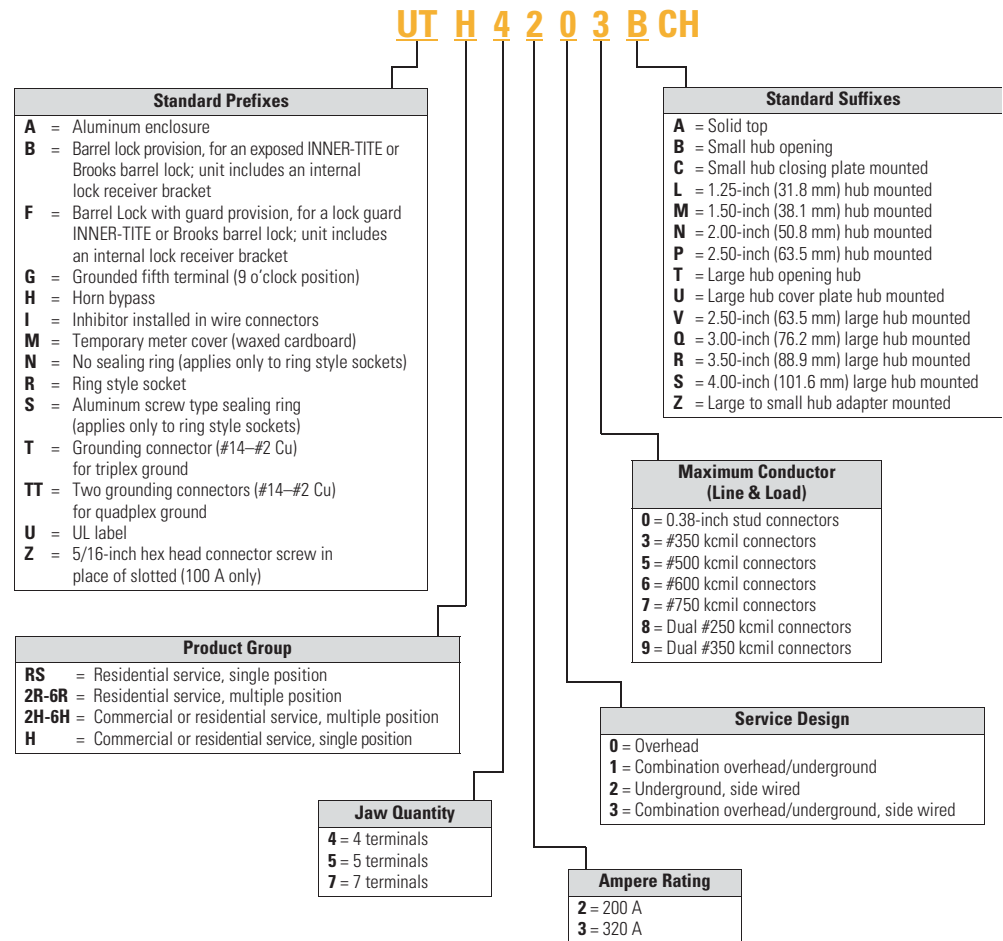

**Product Selection**

**Commercial Lever Bypass**

Ampere Rating	Jaws	Service	Bypass	Connections Line	Load	Opening, Hub or Closure Plate	Catalog Number
320	7	OH/UG	Lever	#4-600 kcmil	#4-600 kcmil	5x5 hub opening	UTTH7336TCH
320	7	OH	Lever	#600 kcmil	Dual #6-350	5x5 hub opening	UTH73069THLCH
320	7	OH/UG	Lever	#14-1/0 cu/al	#6-350 kcmil	5x5 hub cover plate	UTH73369UHLCH
320	7	OH/UG	Lever	#14-1/0 cu/al	#6-350 kcmil	5x5 hub opening	UTH73369THLCH
320	7	OH/UG	Lever	3/8-inch studs	3/8-inch studs	5x5 hub cover plate	UFTH7330UCH
320	7	OH/UG	Lever	#600 kcmil	#600 kcmil	5x5 hub opening	UTH7336TCH
320	7	OH/UG	Lever	3/8-inch studs	3/8-inch studs	5x5 hub cover plate	UTH7330UCH
320	7	OH/UG	Lever	3/8-inch studs	3/8-inch studs	5x5 hub cover plate	UTH7330UFLCH
320	7	OH/UG	Lever	3/8-inch studs	3/8-inch studs	5x5 hub cover plate	UATH7330UFLCH ①
320	7	OH/UG	Lever	3/8-inch studs	3/8-inch studs	5x5 hub opening	UH7330TCPLCH
320	7	OH/UG	Lever	3/8-inch studs	3/8-inch studs	5x5 hub opening	UTH7330TCH
320	7	OH/UG	Lever	3/8-inch studs	3/8-inch studs	5x5 hub-inch opening	UTTH7330TCH
320	7	OH/UG	Lever	3/8-inch studs	3/8-inch studs	5x5 hub cover plate	UH7300UCPLCH
320	7	OH/UG	Lever	3/8-inch studs	3/8-inch studs	5x5 hub cover plate	UTH7300UCH
320	7	OH/UG	Lever	3/8-inch studs	3/8-inch studs	5x5 hub opening	UTH7300TCH
320	7	OH/UG	Lever	#6-350 kcmil	#6-350 kcmil	Hub closure plate	1006353CCH ②
320	5	OH/UG	Lever	3/8-inch studs	3/8-inch studs	5x5 hub cover plate	UTH5330UFLCH
320	5	OH/UG	Lever	3/8-inch studs	3/8-inch studs	5x5 hub cover plate	UTH5330UCH
320	5	OH	Lever	3/8-inch studs	3/8-inch studs	5x5 hub opening	UTH5300TCH
320	5	OH/UG	Lever	3/8-inch studs	3/8-inch studs	5x5 hub cover plate	UATH5330UFLCH
320	4	OH/UG	lever	#4-600 kcmil	#4-600 kcmil	Hub closure plate	1010468CH ②
320	4	UG	Lever	3/8-inch studs	3/8-inch studs	Solid top	UTH4320ACH
320	4	UG	Lever	3/8-inch studs	Dual #6-350	Solid top	UTH43209ACH
320	4	OH/UG	Lever	#6-350 kcmil	#6-350 kcmil	5x5 hub cover plate	UTH4339UCH
320	4	OH/UG	Lever	#6-250 kcmil	#6-250 kcmil	5x5 hub cover plate	UTH4338UCH
320	4	OH/UG	Lever	#4-600 kcmil	#4-600 kcmil	5x5 hub cover plate	UTH4336UCH
320	4	OH/UG	Lever	#4-600 kcmil	#4-600 kcmil	5x5 hub opening	UTH4336TCH
320	4	OH/UG	Lever	#4-600 kcmil	#6-350 kcmil	5x5 hub cover plate	UTH43369UCH
320	4	OH/UG	Lever	#4-600 kcmil	#6-350 kcmil	5x5 hub opening	UTH43369TCH
320	4	OH/UG	Lever	3/8-inch studs	3/8-inch studs	3-5/16 hub cover plate	UTTH4330UCH
320	4	OH/UG	Lever	3/8-inch studs	3/8-inch studs	3-5/16 hub cover plate	UTH4330UCH
320	4	OH/UG	Lever	3/8-inch studs	3/8-inch studs	5x5 hub opening	UBTH4330TCH
320	4	OH/UG	Lever	3/8-inch studs	3/8-inch studs	5x5 hub opening	UTH4330TCH
320	4	OH/UG	Lever	3/8-inch studs	3/8-inch studs	5x5 cover plate	UTH4300UCH
320	4	OH/UG	Lever	3/8-inch studs	3/8-inch studs	5x5 hub opening	UTH4300TCH
320	5	OH/UG	Lever	3/8-inch studs	3/8-inch studs	5x5 hub cover plate	UH5300UKCCH
320	4	OH/UG	Lever	#6-250 kcmil	#4-600 kcmil	5x5 hub cover plate	UH43168UCPLCH
320	4	OH/UG	Lever	#4-600 kcmil	#6-250 kcmil	5x5 hub cover plate	UH43068TCPLCH
320	5	OH/UG	Lever	3/8-inch studs	3/8-inch studs	5x5 hub cover plate	UGTH4330UCH
320	5	OH/UG	Lever	3/8-inch studs	3/8-inch studs	5x5 hub opening	UGTH4330TCH
320	7	OH/UG	Lever	3/8-inch studs	3/8-inch studs	5x5 hub opening	UFTH7330TCH
320	4	OH/UG	Lever	3/8-inch studs	3/8-inch studs	5x5 hub opening	UFTH4330TCH

**Notes**

- ① Aluminum enclosure.
- ② Austin Energy approved.

For dimensions, see **Pages V1-T4-15** and **V1-T4-16**.



# 4.1

## Metering Products

### Meter Sockets

4

#### Commercial Lever Bypass, continued

Ampere Rating	Jaws	Service	Bypass	Connections Line	Load	Opening, Hub or Closure Plate	Catalog Number
320	7	OH/UG	Lever	#4–600 kcmil	#4–600 kcmil	5x5 hub opening	UATH7336TCH
320	5	OH/UG	Lever	3/8-inch studs	3/8-inch studs	5x5 hub cover plate	UATH5330UFLCH
320	4	OH/UG	Lever	#4–600 kcmil	#4–600 kcmil	5x5 hub opening	UATH4336TCH
320	4	OH/UG	Lever	3/8-inch studs	3/8-inch studs	5x5 hub opening	UATH4330TCH
320	4	OH/UG	Lever	3/8-inch studs	3/8-inch studs	5x5 hub cover plate	1009788CH
320	4	OH/UG	Lever	3/8-inch studs	3/8-inch studs	5x5 hub cover plate	1009788ACH <sup>Ⓢ</sup>
320	4	OH/UG	Lever	Dual #6–350	Dual #6–350	(2) 5x5 hub cover plates	1009760ACH
320	4	OH/UG	Lever	Dual #6–350	Dual #6–350	5x5 hub cover plate	1009722CH
320	4	OH/UG	Lever	3/8-inch studs	3/8-inch studs	5x5 hub cover plate	782116975945
320	4	OH/UG	Lever	3/8-inch studs	3/8-inch studs	5x5 hub cover plate	1009260CH
320	7	OH/UG	Lever	#4–600 kcmil/ Dual 1/0–250 kcmil cu/al	#4–600 kcmil/ Dual 1/0–250 kcmil cu/al	5x5 hub opening	1009181CH
320	4	UG	Lever	#6–350 kcmil	#6–350 kcmil	Solid top	1009018CH
320	4	OH/UG	Lever	3/8-inch studs	3/8-inch studs	5x5 hub opening	1008950CH
320	4	OH/UG	Lever	3/8-inch studs	3/8-inch studs	5x5 hub opening	1008948CH
320	4	UG	Lever	3/8-inch studs	3/8-inch studs	Solid top	1008848CH
320	4	OH/UG	Lever	3/8-inch studs	3/8-inch studs	5x5 hub opening	1008837CH
320	4	OH/UG	Lever	3/8-inch studs	3/8-inch studs	5x5 hub opening	1008836CH
320	7	OH/UG	Lever	3/8-inch studs	3/8-inch studs	5x5 hub opening	1008798CH
320	4	OH/UG	Lever	3/8-inch studs	3/8-inch studs	5x5 hub opening	1008793CH
320	5	OH/UG	Lever	3/8-inch studs	3/8-inch studs	5x5 hub opening	1008792CH
320	7	OH/UG	Lever	#4–600 kcmil/ Dual 1/0–250 kcmil cu/al	#4–600 kcmil/ Dual 1/0–250 kcmil cu/al	5x5 hub opening	1008543CH
320	4	OH/UG	Lever	#4–600 kcmil cu/al	#4–600 kcmil cu/al	5x5 hub opening	1008541CH
320	4	UG	Lever	N/A	N/A	Solid top	1008540CH
320	4	OH/UG	Lever	#4–600 kcmil cu/al	#4–600 kcmil cu/al	Solid top	1008435CH
320	4	OH/UG	Lever	3/8-inch studs	3/8-inch studs	5x5 hub opening	1008191CH
320	4	OH/UG	Lever	#6–350 kcmil	#6–350 kcmil	5x5 hub opening	1008068CH
320	4	OH/UG	Lever	N/A	N/A	N/A	1007818CH
320	4	OH/UG	Lever	3/8-inch studs	3/8-inch studs	5x5 hub opening	1007801CH
320	4	OH/UG	Lever	3/8-inch studs	3/8-inch studs	5x5 hub opening	1007672CH
320	4	OH/UG	Lever	#6–350 kcmil	#6–350 kcmil	5x5 hub opening	1006344ACH
320	4	OH/UG	Lever	TBD	TBD	5x5 hub opening	1004984ACH
320	4	OH/UG	N/A	#4–600 kcmil	#4–600 kcmil	3-inch bolt-on hub	1004771BCH
200	7	OH/UG	Lever	3/8-inch studs	3/8-inch studs	N/A	UBTH7230ACH
200	7	OH/UG	Lever	#6–350 kcmil	#6–350 kcmil	5x5 hub cover plate	UTH7233UCH

#### Notes

<sup>Ⓢ</sup> Bolted in shield.

For dimensions, see **Pages V1-T4-15** and **V1-T4-16**.

Commercial Lever Bypass, continued

Ampere Rating	Jaws	Service	Bypass	Connections Line	Load	Opening, Hub or Closure Plate	Catalog Number
200	7	OH/UG	Lever	#6-350 kcmil	#6-350 kcmil	5x5 hub cover plate	UTE7213UFLCH
200	7	OH/UG	Lever	#6-350 kcmil	#6-350 kcmil	3-5/16 hub cover plate	UETH72137UCH
200	7	OH/UG	Lever	#6-350 kcmil	#6-350 kcmil	3-5/16 hub cover plate	UTE7213UCH
200	7	OH/UG	Lever	#6-350 kcmil	#6-350 kcmil	5x5 hub opening	UTE7213THLCH
200	7	OH/UG	Lever	#6-350 kcmil	#6-350 kcmil	5x5 hub opening	UBHRS212BCH
200	7	OH/UG	Lever	#6-350 kcmil	#6-350 kcmil	5x5 hub opening	UBEH7213TCH
200	7	OH/UG	Lever	#6-350 kcmil	#6-350 kcmil	5x5 hub opening	UTFE7213TCH <sup>①</sup>
200	7	OH/UG	Lever	#6-350 kcmil	#6-350 kcmil	Large to small hub adapter	UTE7213ZCH
200	7	OH/UG	Lever	#6-350 kcmil	#6-350 kcmil	5x5 hub opening	UTE7213TCH
200	7	OH/UG	Lever	#6-350 kcmil	#6-350 kcmil	3-5/16 hub cover plate	UTE7213CFLCH
200	7	OH/UG	Lever	#6-350 kcmil	#6-350 kcmil	3-5/16 hub cover plate	UTE7213CCH
200	7	OH/UG	Lever	#6-350 kcmil	#6-350 kcmil	3-5/16 hub opening	UBTE7213BCH
200	7	OH/UG	Lever	#6-350 kcmil	#6-350 kcmil	3-5/16 hub opening	UTE7213BCH
200	7	OH/UG	Lever	3/8-inch studs	3/8-inch studs	5x5 hub cover plate	UTE7210UCH
200	7	OH	Lever	#6-350 kcmil	#6-350 kcmil	5x5 hub opening	UTE7203TCH
200	7	OH	Lever	#6-350 kcmil	#6-350 kcmil	3-5/16 hub opening	UTE7203BCH
200	5	OH/UG	Lever	#6-350 kcmil	#6-350 kcmil	5x5 hub cover plate	UETH5213UCH
200	5	OH/UG	Lever	#6-350 kcmil	#6-350 kcmil	5x5 hub opening	UTE5213TCH
200	5	OH/UG	Lever	#6-350 kcmil	#6-350 kcmil	5x5 hub opening	UTTE5213TCH
200	5	OH/UG	Lever	#6-350 kcmil	#6-350 kcmil	3-5/16 hub cover plate	UTE5213CCH
200	5	OH/UG	Lever	#6-350 kcmil	#6-350 kcmil	3-5/16 hub opening	UTE5213BNDCH
200	5	OH/UG	Lever	#6-350 kcmil	#6-350 kcmil	Large to small hub adapter	UTE5213ZCH
200	5	OH/UG	Lever	#6-350 kcmil	#6-350 kcmil	5x5 hub cover plate	UTE5213UFLCH
200	5	OH/UG	Lever	#6-350 kcmil	#6-350 kcmil	3-5/16 hub cover plate	UTE5213CFLCH
200	5	OH/UG	Lever	#6-350 kcmil	#6-350 kcmil	3-5/16 hub opening	UTE5213BCH
200	5	OH/UG	Lever	3/8-inch studs	3/8-inch studs	3-5/16 hub cover plate	UTE5210CCH
200	5	OH	Lever	#6-350 kcmil	#6-350 kcmil	3-5/16 hub opening	UTE5203BCH
200	4	OH/UG	Lever	#6-350 kcmil	#6-350 kcmil	5x5 hub opening with adapter plate	UTE4213ZCH
200	5	OH/UG	Lever	#6-350 kcmil	#6-350 kcmil	5x5 hub cover plate	UGTE4213CCH
200	4	OH/UG	Lever	#6-350 kcmil	#6-350 kcmil	5x5 hub opening	UTE4213TCH
200	4	OH/UG	Lever	#6-350 kcmil	#6-350 kcmil	5x5 hub cover plate	UTTE4213UCH <sup>②</sup>

Notes

- ① Barrel lock.
- ② TT = quadplex ground.

For dimensions, see Pages V1-T4-15 and V1-T4-16.

# 4.1

## Metering Products

### Meter Sockets

4

#### Commercial Lever Bypass, continued

Ampere Rating	Jaws	Service	Bypass	Connections Line	Load	Opening, Hub or Closure Plate	Catalog Number
200	4	OH/UG	Lever	#6-350 kcmil	#6-350 kcmil	5x5 hub cover plate	UTE4213CCH
200	4	OH/UG	Lever	#6-350 kcmil	#6-350 kcmil	3-5/16 hub opening	UTE4213BCH
200	4	OH	Lever	#6-350 kcmil	#6-350 kcmil	3-5/16 hub opening	UTE4203BCH
200	7	OH/UG	Lever	#6-350 kcmil	#6-350 kcmil	5x5 hub cover plate	UIH7213UCVCH
200	7	OH/UG	Lever	#6-350 kcmil	#6-350 kcmil	3-5/16 hub cover plate	UE7213CCCCH
200	7	OH/UG	Lever	#6-350 kcmil	#6-350 kcmil	3-5/16 hub cover plate	UE7213CCPLCH
200	7	OH/UG	Lever	#6-350 kcmil	#6-350 kcmil	3-5/16 hub opening	UE7213BCPLCH
200	5	OH/UG	Lever	#6-350 kcmil	#6-350 kcmil	3-5/16 hub opening	UGTE4213BCH
200	4	OH/UG	Lever	#6-350 kcmil	#6-350 kcmil	3-5/16 hub cover plate	UGE4213CCCCH
200	7	OH/UG	Lever	#6-350 kcmil	#6-350 kcmil	3-5/16 hub opening	UFTE7213BCH
200	7	OH/UG	Lever	#6-350 kcmil	#6-350 kcmil	5x5 hub opening	UATE7213TCH
200	5	OH/UG	Lever	#6-350 kcmil	#6-350 kcmil	3-5/16 hub cover plate	UATE5213CCH
200	4	OH/UG	Lever	#6-350 kcmil	#6-350 kcmil	5x5 hub cover plate	UATE4213UFLCH
200	5	OH	Lever	#6-350 kcmil	#6-350 kcmil	3-5/16 hub opening	UBGTE4203BCH
200	7	UG	Lever	4/0 compression line	#6-350 kcmil cu/al load	Solid top	1009845ECH
200	5	OH/UG	Lever	#6-350 kcmil	#6-350 kcmil	3-5/16 hub cover plate	1008801ECH
200	5	OH/UG	Lever	3/8-inch studs	3/8-inch studs	3-5/16 hub cover plate	1008832ECH
200	4	UG	Lever	#6-350 kcmil	#6-350 kcmil	Solid top	1007944ECH
200	7	OH/UG	Lever	#6-350 kcmil cu/al	#6-350 kcmil cu/al	5x5 hub opening	1007670ECH
200	7	OH/UG	Lever	#6-350 kcmil	#6-350 kcmil	5x5 hub opening	UTTE7213TCH

**Note**

For dimensions, see **Pages V1-T4-15 and V1-T4-16.**

**Dimensions**

Approximate Dimensions in Inches (mm)

**Commercial Lever Bypass**

Catalog Number	Height	Width	Depth
UTTH7336TCH	39.89 (1013.2)	20.00 (508.0)	6.50 (165.1)
UTH73069THLCH	N/A	N/A	N/A
UTH73369UHLCH	39.89 (1013.2)	20.00 (508.0)	6.50 (165.1)
UTH73369THLCH	39.89 (1013.2)	20.00 (508.0)	6.50 (165.1)
UFTH7330UCH	39.89 (1013.2)	20.00 (508.0)	6.50 (165.1)
UTH7336TCH	39.89 (1013.2)	20.00 (508.0)	6.50 (165.1)
UTH7330UCH	39.89 (1013.2)	20.00 (508.0)	6.50 (165.1)
UTH7330UFLCH	39.89 (1013.2)	20.00 (508.0)	6.50 (165.1)
UATH7330UFLCH ①	39.89 (1013.2)	20.00 (508.0)	6.50 (165.1)
UH7330TCPPLCH	39.89 (1013.2)	20.00 (508.0)	6.50 (165.1)
UTH7330TCH	39.89 (1013.2)	20.00 (508.0)	6.50 (165.1)
UTTH7330TCH	39.89 (1013.2)	20.00 (508.0)	6.50 (165.1)
UH7300UCPLCH	39.89 (1013.2)	20.00 (508.0)	6.50 (165.1)
UTH7300UCH	39.89 (1013.2)	20.00 (508.0)	6.50 (165.1)
UTH7300TCH	34.50 (876.3)	15.00 (381.0)	5.63 (143.0)
UTH5330UFLCH	39.88 (1013.0)	20.00 (508.0)	6.50 (165.1)
UTH5330UCH	39.88 (1013.0)	20.00 (508.0)	6.50 (165.1)
UTH5300TCH	39.88 (1013.0)	20.00 (508.0)	6.50 (165.1)
UATH5330UFLCH	39.88 (1013.0)	20.00 (508.0)	6.50 (165.1)
UTH4320ACH	26.00 (660.4)	15.00 (381.0)	5.68 (144.3)
UTH43209ACH	N/A	N/A	N/A
UTH4339UCH	36.63 (930.4)	15.00 (381.0)	5.69 (144.5)
UTH4338UCH	29.00 (736.6)	15.00 (381.0)	5.69 (144.5)
UTH4336UCH	36.63 (930.4)	15.00 (381.0)	5.69 (144.5)
UTH4336TCH	36.63 (930.4)	15.00 (381.0)	5.69 (144.5)
UTH43369UCH	36.63 (930.4)	15.00 (381.0)	5.69 (144.5)
UTH43369TCH	36.63 (930.4)	15.00 (381.0)	5.69 (144.5)
UTTH4330UCH	36.63 (930.4)	15.00 (381.0)	5.69 (144.5)
UTH4330UCH	36.63 (930.4)	15.00 (381.0)	5.69 (144.5)
UBTH4330TCH	36.63 (930.4)	15.00 (381.0)	5.69 (144.5)
UTH4330TCH	36.63 (930.4)	15.00 (381.0)	5.69 (144.5)
UTH4300UCH	34.50 (876.3)	13.00 (330.2)	4.94 (125.5)
UTH4300TCH	34.50 (876.3)	13.00 (330.2)	4.94 (125.5)
UH5300UKCCH	34.50 (876.3)	13.00 (330.2)	4.94 (125.5)
UH43168UCPLCH	34.50 (876.3)	15.00 (381.0)	5.69 (144.5)
UH43068TCPPLCH	34.50 (876.3)	13.00 (330.2)	4.94 (125.5)
UGTH4330UCH	36.63 (930.4)	15.00 (381.0)	5.69 (144.5)
UGTH4330TCH	36.63 (930.4)	15.00 (381.0)	5.69 (144.5)
UFTH7330TCH	39.88 (1013.0)	20.00 (508.0)	6.50 (165.1)
UFTH4330TCH	36.63 (930.4)	15.00 (381.0)	5.69 (144.5)

**Commercial Lever Bypass, continued**

Catalog Number	Height	Width	Depth
UATH7336TCH	39.88 (1013.0)	20.00 (508.0)	6.50 (165.1)
UATH5330UFLCH	39.88 (1013.0)	20.00 (508.0)	6.50 (165.1)
UATH4336TCH	36.63 (930.4)	15.00 (381.0)	5.69 (144.5)
UATH4330TCH	36.63 (930.4)	15.00 (381.0)	5.69 (144.5)
1009788CH	34.50 (876.3)	13.00 (330.2)	4.94 (125.5)
1009788ACH ②	34.50 (876.3)	13.00 (330.2)	4.94 (125.5)
1009760ACH	36.63 (930.4)	15.00 (381.0)	5.68 (144.3)
1009722CH	36.63 (930.4)	15.00 (381.0)	5.68 (144.3)
782116975945	36.63 (930.4)	15.00 (381.0)	5.69 (144.5)
1009260CH	36.63 (930.4)	15.00 (381.0)	5.69 (144.5)
1009181CH	34.50 (876.3)	15.00 (381.0)	5.69 (144.5)
1009018CH	63.00 (1600.2)	12.97 (329.4)	4.94 (125.5)
1008950CH	39.88 (1013.0)	20.00 (508.0)	6.50 (165.1)
1008948CH	36.63 (930.4)	15.00 (381.0)	5.69 (144.5)
1008848CH	58.00 (1473.2)	12.97 (329.4)	4.94 (125.5)
1008837CH	36.63 (930.4)	15.00 (381.0)	6.50 (165.1)
1008836CH	36.63 (930.4)	15.00 (381.0)	6.50 (165.1)
1008798CH	34.50 (876.3)	15.00 (381.0)	5.69 (144.5)
1008793CH	34.50 (876.3)	13.00 (330.2)	4.94 (125.5)
1008792CH	34.50 (876.3)	13.00 (330.2)	4.94 (125.5)
1008543CH	39.89 (1013.2)	20.00 (508.0)	6.60 (167.6)
1008541CH	36.63 (930.4)	15.00 (381.0)	5.69 (144.5)
1008540CH	N/A	N/A	N/A
1008435CH	26.00 (660.4)	15.00 (381.0)	5.69 (144.5)
1008191CH	36.63 (930.4)	15.00 (381.0)	5.69 (144.5)
1008068CH	34.50 (876.3)	16.44 (417.6)	6.50 (165.1)
1007818CH	N/A	N/A	N/A
1007801CH	28.50 (723.9)	18.00 (457.2)	5.69 (144.5)
1007672CH	36.63 (930.4)	15.00 (381.0)	5.69 (144.5)
1006344ACH	28.50 (723.9)	18.00 (457.2)	5.69 (144.5)
1004984ACH	36.63 (930.4)	15.00 (381.0)	5.69 (144.5)
1004771BCH	36.62 (930.1)	15.00 (381.0)	5.68 (144.3)
UBTH7230ACH	N/A	N/A	N/A
UTH7233UCH	27.00 (685.8)	16.00 (406.4)	5.63 (143.0)

**Notes**

- ① Aluminum enclosure.
- ② Bolted in shield.

Approximate Dimensions in Inches (mm)

## Commercial Lever Bypass, continued

Catalog Number	Height	Width	Depth
UTE7213UFLCH	19.00 (482.6)	13.00 (330.2)	4.94 (125.5)
UETH72137UCH	19.00 (482.6)	13.00 (330.2)	4.94 (125.5)
UTE7213UCH	19.00 (482.6)	13.00 (330.2)	4.94 (125.5)
UTE7213THLCH	19.00 (482.6)	13.00 (330.2)	4.94 (125.5)
UBHRS212BCH	19.00 (482.6)	13.00 (330.2)	4.94 (125.5)
UBEH7213TCH	19.00 (482.6)	13.00 (330.2)	4.94 (125.5)
UFTE7213TCH ①	19.00 (482.6)	13.00 (330.2)	4.94 (125.5)
UTE7213ZCH	19.00 (482.6)	13.00 (330.2)	4.94 (125.5)
UTE7213TCH	19.00 (482.6)	13.00 (330.2)	4.94 (125.5)
UTE7213CFLCH	19.00 (482.6)	13.00 (330.2)	4.94 (125.5)
UTE7213CCH	19.00 (482.6)	13.00 (330.2)	4.94 (125.5)
UBTE7213BCH	19.00 (482.6)	13.00 (330.2)	4.94 (125.5)
UTE7213BCH	19.00 (482.6)	13.00 (330.2)	4.94 (125.5)
UTE7210UCH	24.69 (627.1)	13.00 (330.2)	4.94 (125.5)
UTE7203TCH	19.00 (482.6)	10.50 (266.7)	4.94 (125.5)
UTE7203BCH	19.00 (482.6)	10.50 (266.7)	4.94 (125.5)
UETH5213UCH	19.00 (482.6)	13.00 (330.2)	4.94 (125.5)
UTE5213TCH	19.00 (482.6)	13.00 (330.2)	4.94 (125.5)
UTTE5213TCH	19.00 (482.6)	13.00 (330.2)	4.94 (125.5)
UTE5213CCH	19.00 (482.6)	13.00 (330.2)	4.94 (125.5)
UTE5213BNDCH	19.00 (482.6)	13.00 (330.2)	4.94 (125.5)
UTE5213ZCH	19.00 (482.6)	13.00 (330.2)	4.94 (125.5)
UTE5213UFLCH	19.00 (482.6)	13.00 (330.2)	4.94 (125.5)
UTE5213CFLCH	19.00 (482.6)	13.00 (330.2)	4.94 (125.5)
UTE5213BCH	19.00 (482.6)	13.00 (330.2)	4.94 (125.5)
UTE5210CCH	20.13 (511.3)	13.00 (330.2)	4.94 (125.5)
UTE5203BCH	19.00 (482.6)	10.50 (266.7)	4.94 (125.5)
UTE4213ZCH	19.00 (482.6)	13.00 (330.2)	4.94 (125.5)
UGTE4213CCH	19.00 (482.6)	13.00 (330.2)	4.94 (125.5)
UTE4213TCH	19.00 (482.6)	13.00 (330.2)	4.94 (125.5)
UTTE4213UCH ②	19.00 (482.6)	13.00 (330.2)	4.94 (125.5)
UTE4213CCH	19.00 (482.6)	13.00 (330.2)	4.94 (125.5)
UTE4213BCH	19.00 (482.6)	13.00 (330.2)	4.94 (125.5)
UTE4203BCH	19.00 (482.6)	10.50 (266.7)	4.94 (125.5)
UIH7213UCVCH	19.00 (482.6)	13.00 (330.2)	4.94 (125.5)
UE7213CCCH	19.00 (482.6)	13.00 (330.2)	4.94 (125.5)
UE7213CCPLCH	19.00 (482.6)	13.00 (330.2)	4.94 (125.5)
UE7213BCPLCH	19.00 (482.6)	13.00 (330.2)	4.94 (125.5)

## Commercial Lever Bypass, continued

Catalog Number	Height	Width	Depth
UGTE4213BCH	19.00 (482.6)	13.00 (330.2)	4.94 (125.5)
UGE4213CCCH	19.00 (482.6)	13.00 (330.2)	4.94 (125.5)
UFTE7213BCH	19.00 (482.6)	13.00 (330.2)	4.94 (125.5)
UATE7213TCH	19.00 (482.6)	13.00 (330.2)	4.94 (125.5)
UATE5213CCH	19.00 (482.6)	13.00 (330.2)	4.94 (125.5)
UATE4213UFLCH	19.00 (482.6)	13.00 (330.2)	4.94 (125.5)
UBGTE4203BCH	19.00 (482.6)	10.50 (266.7)	4.94 (125.5)
1009845ECH	64.00 (1625.6)	11.00 (279.4)	6.00 (152.4)
1008801ECH	19.00 (482.6)	13.00 (330.2)	4.94 (125.5)
1008832ECH	24.69 (627.1)	13.00 (330.2)	4.94 (125.5)
1007944ECH	22.00 (558.8)	16.00 (406.4)	5.69 (144.5)
1007670ECH	19.00 (482.6)	13.00 (330.2)	4.94 (125.5)
UTTE7213TCH	19.00 (482.6)	13.00 (330.2)	4.94 (125.5)

**Notes**

① Barrel lock.

② TT = quadplex ground.

Multiple Position Horizontal Ganged Sockets



Contents

Description	Page
Single Meter Sockets	V1-T4-2
Commercial Lever Bypass Sockets	V1-T4-10
Multiple Position Horizontal Ganged Sockets	
Product Selection	V1-T4-18
Dimensions	V1-T4-21
Instrument Rated Sockets	V1-T4-23
Residential Pedestals	V1-T4-28
Meter Socket Accessories	V1-T4-30

Multiple Position Horizontal Ganged Sockets

Product Description

- Available in 100 A and 200 A designs
- Available in 2-position through 6-position designs
- Multiple service design offerings
- Multiple line/load lug configurations
- Residential or lever bypass socket designs

Multiple hub opening and closure plate sizes available

Catalog Number Selection

Single Meter Sockets 2R-6R and 2H-6H Group

Note: The "U" prefix is always used first followed by other prefixes required in alphabetical order.

**UT 2R 1 1 2 1 B CH**

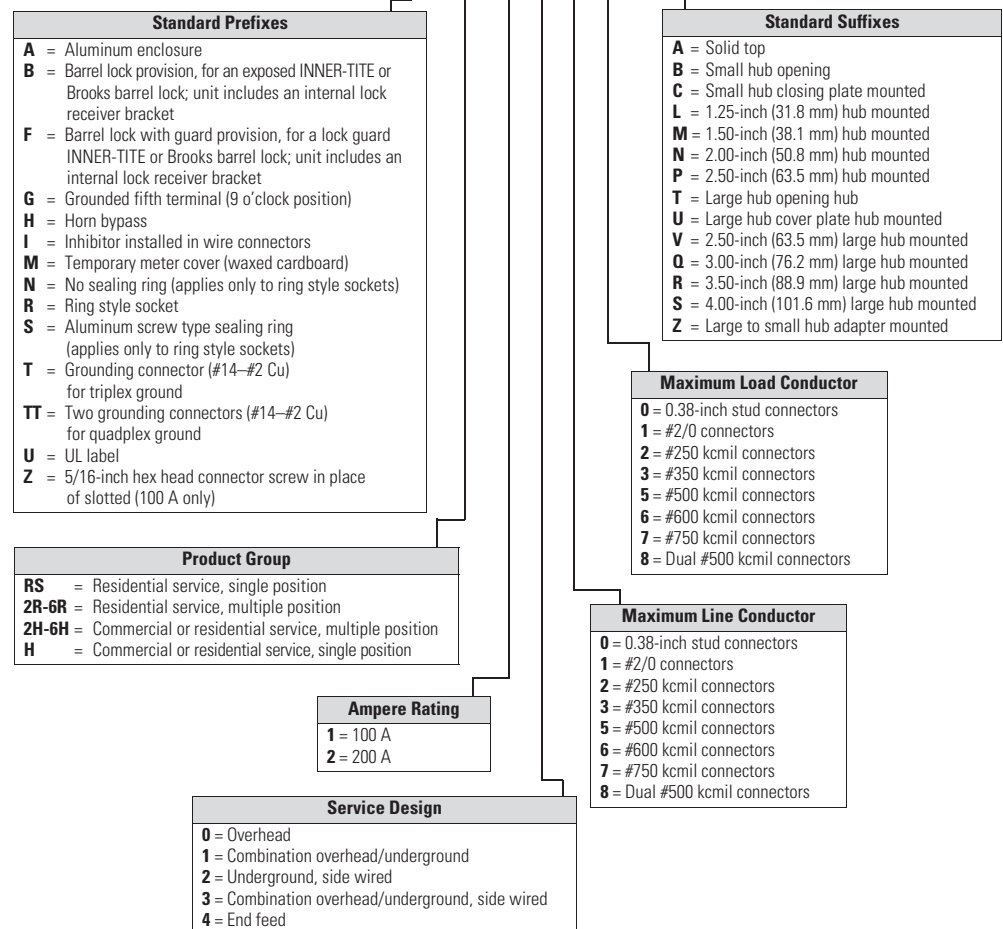

#### Product Selection

UT2R2332BCH



#### Horizontal Design—Multi Position Ringless

Ampere Rating	Jaws	Position	Service	Bypass	Connections Line	Load	Opening, Hub or Closure Plate	Catalog Number
200	4	2	OH/UG	Horn	#6–350 kcmil	#8–250 kcmil	5x5 hub opening	1004401BCH
200	4	3	OH/UG	Horn	#6–350 kcmil	#8–250 kcmil	5x5 hub opening	1004404BCH
200	5	2	OH/UG	Horn	#6–350 kcmil	#8–250 kcmil	5x5 hub opening	1004418ACH
200	4	2	OH/UG	—	3/8-inch stud	#8–250 kcmil	5x5 hub cover plate	1006737BCH
200	4	2	OH/UG	Horn	3/8-inch stud	#8–250 kcmil	5x5 hub opening	1007700CH
200	4	3	OH/UG	Horn	3/8-inch stud	#8–250 kcmil	Hub opening	1007701CH
200	4	2	OH/UG	Horn	#6–350 kcmil	#8–250 kcmil	5x5 hub cover plate	1008842CH
200	4	3	OH/UG	Horn	1/0–500 kcmil cu/al	#8–250 kcmil	5x5 hub cover plate	1008843CH
200	4	4	OH/UG	Horn	1/0–500 kcmil cu/al	#8–250 kcmil	5x5 hub cover plate	1008844CH
200	4	2	OH/UG	Horn	#6–350 kcmil	#8–250 kcmil	5x5 hub cover plate	1008958CH
200	4	3	OH/UG	Horn	1/0–500 kcmil cu/al	#8–250 kcmil	5x5 hub cover plate	1008959CH
200	4	4	OH/UG	Horn	1/0–500 kcmil cu/al	#8–250 kcmil	5x5 hub cover plate	1008960CH
200	4	5	OH/UG	Horn	(2) 1/0–500 kcmil cu/al	#8–250 kcmil	(2) 5x5 hub cover plate	1009579ACH
200	4	4	OH/UG	Horn	1/0–500 kcmil cu/al	#8–250 kcmil	5x5 hub opening	U4R2352TDQCH
200	4	5	OH/UG	Horn	(2) 1/0–500 kcmil cu/al	#8–250 kcmil	(2) 5x5 hub opening	U5R2392TTDQCH
200	4	6	OH/UG	Horn	(2) 1/0–500 kcmil cu/al	#8–250 kcmil	5x5 hub opening (2) places	U6R2392TTDQCH
200	4	4	OH/UG	Horn	1/0–500 kcmil cu/al	#8–250 kcmil	5x5 hub opening	UBH4R2352TCH
200	4	2	OH/UG	Horn	#6–350 kcmil	#8–250 kcmil	5x5 hub opening	UBH2R2332TCH
200	4	3	OH/UG	Horn	#6–350 kcmil	#8–250 kcmil	5x5 hub opening	UBH3R2332TCH
200	4	4	OH/UG	Horn	3/8-inch stud	#8–250 kcmil	5x5 hub cover plate	UEHT4R2302UCH
200	4	3	OH/UG	Horn	3/8-inch stud	#8–250 kcmil	5x5 hub cover plate	UEHT3R2302UCH
200	4	2	OH/UG	Horn	3/8-inch stud	#8–250 kcmil	5x5 hub cover plate	UEHT2R2302UCH
200	4	2	UG	Horn	#6–350 kcmil	#8–250 kcmil	Solid top	UHI2R2332ACVCH
200	4	2	OH/UG	Horn	#6–350 kcmil	#8–250 kcmil	Hub opening	UHI2R2332TCVCH
200	4	4	UG	Horn	1/0–500 kcmil cu/al	#8–250 kcmil	Solid top	UHI4R2352ACVCH
200	4	2	OH/UG	Horn	#6–350 kcmil	#8–250 kcmil	5x5 hub cover plate	UHTT2R2332UCH
200	4	2	OH/UG	Horn	#6–350 kcmil	#8–250 kcmil	5x5 hub opening	UHT2R2332TCH
200	4	3	OH/UG	Horn	#6–350 kcmil	#8–250 kcmil	5x5 hub opening	UHT3R2332TCH
200	4	3	OH/UG	Horn	1/0–500 kcmil cu/al	#8–250 kcmil	5x5 hub cover plate	UHT3R2352UCH
200	4	4	OH/UG	Horn	1/0–500 kcmil cu/al	#8–250 kcmil	5x5 hub opening	UHT4R2352TCH
200	4	4	OH/UG	—	1/0–500 kcmil cu/al	#8–250 kcmil	5x5 hub cover plate	UT4R2352UFLCH
200	4	4	OH/UG	Horn	1/0–500 kcmil cu/al	#8–250 kcmil	5x5 hub cover plate	UHT4R2352UCH
200	5	2	OH/UG	Lever	1/0–500 kcmil cu/al	#6–350 kcmil	5x5 hub opening	UT2H52353TCH
200	4	2	OH/UG	Horn	#6–350 kcmil	#8–250 kcmil	5x5 hub cover plate	UHT2R2332UCH
200	4	2	OH/UG	—	#6–350 kcmil	#8–250 kcmil	3-5/16 hub opening	UT2R2332BCH
200	4	2	OH/UG	—	#6–350 kcmil	#8–250 kcmil	5x5 hub opening	UAT2R2332TCH <sup>①</sup>
200	4	2	OH/UG	—	#6–350 kcmil	#8–250 kcmil	5x5 hub opening	UT2R2332TCH
200	4	2	OH/UG	—	#6–350 kcmil	#8–250 kcmil	5x5 hub opening	U2R2332TCPLCH
200	4	2	OH/UG	—	#6–350 kcmil	#8–250 kcmil	5x5 hub cover plate	U2R2332UCPLCH
200	4	2	OH/UG	Horn	#6–350 kcmil	#8–250 kcmil	5x5 hub opening	U2R2332TDQCH
200	4	2	OH/UG	—	#6–350 kcmil	#8–250 kcmil	5x5 hub cover plate	UT2R2332UCH
200	4	3	OH/UG	Horn	#6–350 kcmil	#8–250 kcmil	Large 5X5 hub opening	U3R2332TDQCH

#### Notes

<sup>①</sup> Aluminum enclosure.

For dimensions, see **Page V1-T4-21**.

UT2R1121BCH



Horizontal Design—Multi Position Ringless, continued

Ampere Rating	Jaws	Position	Service	Bypass	Connections Line	Load	Opening, Hub or Closure Plate	Catalog Number
200	4	3	OH/UG	Lever	1/0–500 kcmil cu/al	#6–350 kcmil	5x5 hub opening	UT3H42353TCH
200	5	3	OH/UG	Lever	1/0–500 kcmil cu/al	#6–350 kcmil	5x5 hub opening	UT3H52353TCH
200	7	3	OH/UG	Lever	1/0–500 kcmil cu/al	#6–350 kcmil	5x5 hub cover plate	UT3H72353UHLCH
200	4	3	OH/UG	—	#6–350 kcmil	#8–250 kcmil	5x5 hub opening	UT3R2332TCH
200	4	3	OH/UG	—	#6–350 kcmil	#8–250 kcmil	5x5 hub cover plate	UT3R2332UCH
200	4	3	OH/UG	—	1/0–500 kcmil cu/al	#8–250 kcmil	5x5 hub opening	UT3R2352TCH
200	4	4	OH/UG	—	1/0–500 kcmil cu/al	#8–250 kcmil	5x5 hub opening	UT4R2352TCH
200	4	5	OH/UG	Horn	(2) 1/0–500 kcmil cu/al	#8–250 kcmil	5x5 hub opening (in two places)	UHT5R2392TTCH
200	4	5	OH/UG	—	(2) 1/0–500 kcmil cu/al	#8–250 kcmil	5x5 hub opening (in two places)	UT5R2392TCH
200	7	5	OH/UG	Lever	Dual 1/0–500 kcmil	#6–350 kcmil	(2) 5X5 hub closure plates	UT5H72393UUHLCH
200	4	6	OH/UG	Horn	(2) 1/0–500 kcmil cu/al	#8–250 kcmil	5x5 hub opening (in two places)	UHT6R2392TTCH
200	4	6	OH/UG	—	(2) 1/0–500 kcmil cu/al	#8–250 kcmil	5x5 hub opening (in two places)	UT6R2392TCH
200	4	6	OH/UG	—	(2) 1/0–500 kcmil cu/al	#8–250 kcmil	5x5 closure plate (in two places)	UT6R2392UFLCH
200	7	6	OH/UG	Lever	Dual 1/0–500 kcmil	#6–350 kcmil	5x5 closure plate (in two places)	UT6H72393UUHLCH
200	4	6	OH/UG	Horn	(2) 1/0–500 kcmil cu/al	#8–250 kcmil	5x5 hub opening (in two places)	UHT6R2392TTCH
150	4	2	OH/UG	Horn	#6–350 kcmil	#8–250 kcmil	3-5/16 hub opening	U2R5432BDQCH
150	4	5	OH/UG	—	#6–350 kcmil	#8–250 kcmil	3-5/16 hub opening (in two places)	UT5R5632BCH
100	4	6	OH/UG	—	#6–350 kcmil	#8–2/0 cu/al	3-5/16 hub opening	UT6R1131BCH
100	4	2	OH/UG	Horn	#6–250 kcmil	#8–2/0 cu/al	5x5 hub opening	1004426ACH
100	4	2	OH/UG	Horn	#6–250 kcmil	#8–2/0 cu/al	3-5/16 hub opening	1008951CH
100	4	3	OH/UG	Horn	#6–250 kcmil	#8–2/0 cu/al	3-5/16 hub opening	1008952CH
100	4	2	OH/UG	Horn	#6–250 kcmil	#8–2/0 cu/al	3-5/16 hub cover plate	1009693CH
100	4	3	OH/UG	Horn	#6–250 kcmil	#8–2/0 cu/al	3-5/16 hub cover plate	1009694CH
100	4	4	OH/UG	Horn	#6–250 kcmil	#8–2/0 cu/al	3-5/16 hub cover plate	1009695CH
100	4	5	OH/UG	Horn	#6–250 kcmil	#8–2/0 cu/al	3-5/16 hub cover plate	1009696CH
100	4	6	OH/UG	—	#6–350 kcmil	#8–2/0 cu/al	3-5/16 hub cover plate	UAT26R1131CFCLCH <sup>①</sup>
100	4	2	OH/UG	Horn	#6–250 kcmil	#8–2/0 cu/al	3-5/16 hub opening	UBH2R1121BCH
100	4	3	OH/UG	Horn	#6–250 kcmil	#8–2/0 cu/al	3-5/16 hub opening	UBH3R1121BCH
100	4	4	OH/UG	Horn	#6–250 kcmil	#8–2/0 cu/al	3-5/16 hub opening	UBH4R1121BCH
100	4	2	OH/UG	Horn	#6–250 kcmil	#8–2/0 cu/al	3-5/16 hub opening	UHT2R1121BCH
100	4	4	OH/UG	—	#6–250 kcmil	#8–2/0 cu/al	3-5/16 hub opening	UT4R1121BCH
100	4	4	OH/UG	—	#6–250 kcmil	#8–2/0 cu/al	3-5/16 closure plate	UT4R1121CCH
100	4	4	OH/UG	Horn	#6–250 kcmil	#8–2/0 cu/al	3-5/16 hub opening	UHT4R1121BCH
100	4	5	OH/UG	Horn	#6–250 kcmil	#8–2/0 cu/al	3-5/16 hub opening	UHT5R1121BCH
100	4	5	OH/UG	—	#6–250 kcmil	#8–2/0 cu/al	3-5/16 hub opening	UT5R1121BCH
100	4	5	OH/UG	—	#6–250 kcmil	#8–2/0 cu/al	3-5/16 closure plate	UT5R1121CCH
100	4	2	OH/UG	—	#6–250 kcmil	#8–2/0 cu/al	3-5/16 hub opening	UT2R1121BCH
100	4	2	OH/UG	—	#6–250 kcmil	#8–2/0 cu/al	3-5/16 closure plate	UT2R1121CCH
100	4	2	OH/UG	Horn	#6–250 kcmil	#8–2/0 cu/al	3-5/16 closure plate	UHT2R1421CCH
100	4	2	OH/UG	—	#6–250 kcmil	#8–2/0 cu/al	3-5/16 hub opening 3-5/16 hub cover plate	UT2R1421BCH
100	4	3	OH/UG	Horn	#6–250 kcmil	#8–2/0 cu/al	3-5/16 hub opening	UHT3R1121BCH
100	4	3	OH/UG	—	#6–250 kcmil	#8–2/0 cu/al	3-5/16 hub opening	UT3R1121BCH

Notes

① Aluminum enclosure.

For dimensions, see Page V1-T4-21.



## Horizontal Design—Multi Position Ring Type

Ampere Rating	Jaws	Position	Service	Bypass	Connections		Opening, Hub or Closure Plate	Catalog Number
					Line	Load		
200	4	2	OH/UG	—	1/0–500 kcmil cu/al	#8–250 kcmil	5x5 hub opening	<b>U2R2352TCRCH</b>
200	4	2	OH/UG	—	#6–350 kcmil	#8–250 kcmil	5x5 hub cover plate	<b>URT2R2332UCH</b>
200	5	4	OH/UG	—	1/0–500 kcmil cu/al	#8–250 kcmil	Large 5x5 hub opening	<b>U4R2352TCRCH</b>
125	5	2	OH	—	#8–350 kcmil	#8–2/0 cu/al	Hub opening	<b>U2V1031BCRCH</b> ①
125	5	3	OH	—	#8–350 kcmil	#8–2/0 cu/al	Hub opening	<b>U3V1031BCRCH</b> ①
100	5	2	OH/UG	—	#6–250 kcmil	#8–2/0 cu/al	3-5/16 opening	<b>U2R1121BCRCH</b>
100	5	3	OH/UG	—	#6–250 kcmil	#8–2/0 cu/al	3-5/16 opening	<b>U3R1121BCRCH</b>
100	5	4	OH/UG	—	#6–250 kcmil	#8–2/0 cu/al	3-5/16 opening	<b>U4R1121BCRCH</b>
100	5	5	OH/UG	—	#6–250 kcmil	#8–2/0 cu/al	3-5/16 opening	<b>U5R1121BCRCH</b>

**Notes**

① Vertical gang.

For dimensions, see **Page V1-T4-22**.

**Dimensions**

Approximate Dimensions in Inches (mm)

**Horizontal Design—Multi Position Ringless**

Catalog Number	Height	Width	Depth
1004401BCH	14.13 (358.9)	24.31 (617.5)	5.38 (136.7)
1004404BCH	14.13 (358.9)	32.47 (824.7)	5.38 (136.7)
1004418ACH	14.13 (358.9)	24.31 (617.5)	5.38 (136.7)
1006737BCH	14.13 (358.9)	24.31 (617.5)	5.38 (136.7)
1007700CH	14.13 (358.9)	24.31 (617.5)	5.38 (136.7)
1007701CH	14.13 (358.9)	32.47 (824.7)	5.38 (136.7)
1008842CH	14.13 (358.9)	24.31 (617.5)	5.38 (136.7)
1008843CH	14.13 (358.9)	32.47 (824.7)	5.38 (136.7)
1008844CH	14.13 (358.9)	40.63 (1032.0)	5.38 (136.7)
1008958CH	14.13 (358.9)	24.31 (617.5)	5.38 (136.7)
1008959CH	14.13 (358.9)	32.47 (824.7)	5.38 (136.7)
1008960CH	14.13 (358.9)	40.63 (1032.0)	5.38 (136.7)
1009579ACH	14.13 (358.9)	54.78 (1391.4)	5.38 (136.7)
U4R2352TDQCH	14.13 (358.9)	40.63 (1032.0)	5.38 (136.7)
U5R2392TTDQCH	14.13 (358.9)	62.94 (1598.7)	5.38 (136.7)
U6R2392TTDQCH	14.13 (358.9)	62.94 (1598.7)	5.38 (136.7)
UBH4R2352TCH	14.13 (358.9)	40.63 (1032.0)	5.38 (136.7)
UBH2R2332TCH	14.13 (358.9)	24.31 (617.5)	5.38 (136.7)
UBH3R2332TCH	14.13 (358.9)	32.47 (824.7)	5.38 (136.7)
UEHT4R2302UCH	14.13 (358.9)	40.63 (1032.0)	5.38 (136.7)
UEHT3R2302UCH	14.13 (358.9)	32.47 (824.7)	5.38 (136.7)
UEHT2R2302UCH	14.13 (358.9)	24.31 (617.5)	5.38 (136.7)
UHI2R2332ACVCH	14.13 (358.9)	24.31 (617.5)	5.38 (136.7)
UHI2R2332TCVCH	14.13 (358.9)	24.31 (617.5)	5.38 (136.7)
UHI4R2352ACVCH	14.13 (358.9)	40.63 (1032.0)	5.38 (136.7)
UHTT2R2332UCH	14.13 (358.9)	24.31 (617.5)	5.38 (136.7)
UHT2R2332TCH	14.13 (358.9)	24.31 (617.5)	5.38 (136.7)
UHT3R2332TCH	14.13 (358.9)	32.94 (836.7)	5.38 (136.7)
UHT3R2352UCH	14.13 (358.9)	32.47 (824.7)	5.38 (136.7)
UHT4R2352TCH	14.13 (358.9)	40.63 (1032.0)	5.38 (136.7)
UT4R2352UFLCH	14.13 (358.9)	40.63 (1032.0)	5.38 (136.7)
UHT4R2352UCH	14.13 (358.9)	40.63 (1032.0)	5.38 (136.7)
UT2H52353TCH	23.56 (598.4)	32.78 (832.6)	6.00 (152.4)
UHT2R2332UCH	14.13 (358.9)	24.31 (617.5)	5.38 (136.7)
UT2R2332BCH	14.13 (358.9)	24.31 (617.5)	5.38 (136.7)
UAT2R2332TCH ①	14.13 (358.9)	24.31 (617.5)	5.38 (136.7)
UT2R2332TCH	14.13 (358.9)	24.31 (617.5)	5.38 (136.7)
U2R2332TCPLCH	14.13 (358.9)	24.31 (617.5)	5.38 (136.7)
U2R2332UCPLCH	14.13 (358.9)	24.31 (617.5)	5.38 (136.7)
U2R2332TDQCH	14.13 (358.9)	24.31 (617.5)	5.38 (136.7)
UT2R2332UCH	14.13 (358.9)	24.31 (617.5)	5.38 (136.7)
U3R2332TDQCH	14.13 (358.9)	32.47 (824.7)	5.38 (136.7)
UT3H42353TCH	23.56 (598.4)	43.91 (1115.3)	6.00 (152.4)
UT3H52353TCH	23.56 (598.4)	43.91 (1115.3)	6.00 (152.4)
UT3H72353UHLCH	23.56 (598.4)	43.91 (1115.3)	5.38 (136.7)

**Horizontal Design—Multi Position Ringless, continued**

Catalog Number	Height	Width	Depth
UT3R2332TCH	14.13 (358.9)	32.47 (824.7)	5.38 (136.7)
UT3R2332UCH	14.13 (358.9)	32.47 (824.7)	5.38 (136.7)
UT3R2352TCH	14.13 (358.9)	40.63 (1032.0)	5.38 (136.7)
UT4R2352TCH	14.13 (358.9)	40.63 (1032.0)	5.38 (136.7)
UHT5R2392TTCH	14.13 (358.9)	54.78 (1391.4)	5.38 (136.7)
UT5R2392TTCH	14.13 (358.9)	54.78 (1391.4)	5.38 (136.7)
UT5H72393UUHLCH	29.56 (750.8)	72.15 (1832.6)	6.00 (152.4)
UHT6R2392TTCH	14.13 (358.9)	62.94 (1598.7)	5.38 (136.7)
UT6R2392TTCH	14.13 (358.9)	62.94 (1598.7)	5.38 (136.7)
UT6R2392UFLCH	14.13 (358.9)	62.94 (1598.7)	5.38 (136.7)
UT6H72393UUHLCH	23.56 (598.4)	83.28 (2115.3)	6.00 (152.4)
UHT6R2392TCH	14.13 (358.9)	62.94 (1598.7)	5.38 (136.7)
U2R5432BDQCH	14.13 (358.9)	20.16 (512.1)	5.38 (136.7)
UT5R5632BCH	14.13 (358.9)	48.63 (1235.2)	5.38 (136.7)
UT6R1131BCH	14.13 (358.9)	56.93 (1446.0)	4.50 (114.3)
1004426ACH	14.13 (358.9)	24.31 (617.5)	4.50 (114.3)
1008951CH	14.13 (358.9)	24.31 (617.5)	4.50 (114.3)
1008952CH	14.13 (358.9)	32.47 (824.7)	4.50 (114.3)
1009693CH	14.13 (358.9)	24.16 (613.7)	5.38 (136.7)
1009694CH	14.13 (358.9)	32.31 (820.7)	5.38 (136.7)
1009695CH	14.13 (358.9)	49.94 (1268.5)	5.38 (136.7)
1009696CH	14.13 (358.9)	48.63 (1235.2)	5.38 (136.7)
UAT26R1131CFLCH	14.13 (358.9)	56.94 (1446.3)	4.50 (114.3)
UBH2R1121BCH	14.13 (358.9)	24.94 (633.5)	4.50 (114.3)
UBH3R1121BCH	14.13 (358.9)	32.47 (824.7)	4.50 (114.3)
UBH4R1121BCH	14.13 (358.9)	40.63 (1032.0)	4.50 (114.3)
UHT2R1121BCH	14.13 (358.9)	24.31 (617.5)	4.50 (114.3)
UT4R1121BCH	14.13 (358.9)	40.63 (1032.0)	4.50 (114.3)
UT4R1121CCH	14.13 (358.9)	40.63 (1032.0)	4.50 (114.3)
UHT4R1121BCH	14.13 (358.9)	40.63 (1032.0)	4.50 (114.3)
UHT5R1121BCH	14.13 (358.9)	48.78 (1239.0)	4.50 (114.3)
UT5R1121BCH	14.13 (358.9)	48.78 (1239.0)	4.50 (114.3)
UT5R1121CCH	14.13 (358.9)	48.78 (1239.0)	4.50 (114.3)
UT2R1121BCH	14.13 (358.9)	24.31 (617.5)	4.50 (114.3)
UT2R1121CCH	14.13 (358.9)	24.31 (617.5)	4.50 (114.3)
UHT2R1421CCH	14.13 (358.9)	20.16 (512.1)	5.38 (136.7)
UT2R1421BCH	14.13 (358.9)	20.16 (512.1)	5.38 (136.7)
UHT3R1121BCH	14.13 (358.9)	32.47 (824.7)	4.50 (114.3)
UT3R1121BCH	14.13 (358.9)	32.47 (824.7)	4.50 (114.3)

**Note**  
 ① Aluminum enclosure.

# 4.1

## Metering Products

### Meter Sockets

Approximate Dimensions in Inches (mm)

#### Horizontal Design—Multi Position Ring Type

Catalog Number	Height	Width	Depth
U2R2352TCRCH	14.13 (358.9)	24.31 (617.5)	5.38 (136.7)
URT2R2332UCH	14.13 (358.9)	24.31 (617.5)	5.38 (136.7)
U4R2352TCRCH	14.13 (358.9)	48.00 (1219.2)	5.38 (136.7)
U2V1031BCRCH ①	8.00 (203.2)	25.63 (650.9)	4.38 (111.1)
U3V1031BCRCH ①	8.00 (203.2)	35.88 (911.2)	4.38 (111.1)
U2R1121BCRCH	14.13 (358.9)	28.00 (711.2)	4.50 (114.3)
U3R1121BCRCH	14.13 (358.9)	38.00 (965.2)	4.50 (114.3)
U4R1121BCRCH	14.13 (358.9)	48.00 (1219.2)	4.50 (114.3)
U5R1121BCRCH	14.13 (358.9)	58.00 (1473.2)	4.50 (114.3)

**Note**

① Vertical gang.

**Instrument Rated Sockets**



**Contents**

<i><b>Description</b></i>	<i><b>Page</b></i>
Single Meter Sockets .....	<b>V1-T4-2</b>
Commercial Lever Bypass Sockets .....	<b>V1-T4-10</b>
Multiple Position Horizontal Ganged Sockets .....	<b>V1-T4-17</b>
Instrument Rated Sockets	
Product Selection .....	<b>V1-T4-24</b>
Cross-Reference .....	<b>V1-T4-25</b>
Dimensions .....	<b>V1-T4-27</b>
Residential Pedestals .....	<b>V1-T4-28</b>
Meter Socket Accessories .....	<b>V1-T4-30</b>

**Instrument Rated Sockets**

**Product Description**

- Available in 6, 7, 8 and 13 terminal designs
- 20 A ratings standard
- Multiple service designs available (overhead, underground, overhead/underground)
- Multiple hub opening and closure plate sizes available
- 600 Vac rated
- Single cover/dual cover availability
- Provisional test switches and factory-installed test switch designs available

# 4.1

## Metering Products

### Meter Sockets

#### Product Selection

USTS132CCH



#### Instrument Rated Sockets

Ampere Rating	Jaws	Service	Opening, Hub or Closure Plate	Catalog Number
20	13 terminal	UG	Solid top	USTH131A123CH
20	13 terminal	OH/UG	3-5/16 hub cover plate	USTS131B102CH
20	13 terminal	OH/UG	3-5/16 hub cover plate	USTS132B101CH
20	13 terminal	OH/UG	3-5/16 hub cover plate	USTS132CCH
20	13 terminal	OH/UG	1-inch bolt-on hub	1008694ACH
20	8 terminal	OH/UG	1-inch bolt-on hub	1008695ACH
20	13 terminal	N/A	N/A	1007003BCH
20	13 terminal	Solid top and bottom	Solid top	1007003CCH
20	13 terminal	OH/UG	3-5/16 hub cover plate	USTL131C207CH
20	13 terminal	OH/UG	Hub opening	USTS131BCH
20	13 terminal	OH/UG	1-1/4-inch bolt-on hub	USTS131L143CH
20	13 terminal	N/A	N/A	USTS132BCH
20	6 terminal	OH/UG	Hub opening	USTS61B138CH
20	6 terminal	OH/UG	Hub opening	UST61BCH
20	8 terminal	OH/UG	Hub opening	USTS82B166CH
20	8 terminal	N/A	Solid top and bottom	1007361BCH
N/A	N/A	N/A	N/A	1008539CH
20	13 terminal	OH/UG	3-5/16 hub cover plate	UASTS131C226CH
20	13 terminal	OH	3-5/16 hub cover plate	1004671CH
20	7 terminal	OH	3-5/16 hub cover plate	ULTS131CCH
20	6 terminal	UG	Solid top	STL61A433CH
20	13 terminal	UG	Solid top	STL131A120CH

**Cross-Reference**

**Meter Sockets**

Description	Manufacturer	
	Eaton Part Number	Milbank Part Number
125 A, OH/UG, ringless, triplex ground, hub opening	UTRS101BE	U7487-RL-TG
125 A, OH/UG, ringless, triplex ground, hub cover plate	UTRS101CE	U7487-XL-TG
125 A, OH/UG, ringless, triplex ground, hub opening, horn bypass	UHTRS101BE	U7487-RL-TG-KK
125 A, OH/UG, ringless, triplex ground, hub cover plate, horn bypass	UHTRS101CE	U7487-XL-TG-KK
125 A, OH/UG, ringless, triplex ground, hub opening, fifth terminal	UTRS101BCH + MSR5TK	U7487-RL-TG-5T
125 A, OH/UG, ringless, triplex ground, hub cover plate, fifth terminal	UTRS101CE + MSR5TK	U7487-XL-TG-5T
125 A, OH/UG, ringless, triplex ground, hub opening, horn bypass, fifth terminal	UHTRS101BCH + MSR5TK	U7487-RL-TG-KK-5T
125 A, OH/UG, ringless, triplex ground, hub cover plate, horn bypass, fifth terminal	UGHTRS101CE + MSR5TK	U7487-XL-TG-KK-5T
200 A, OH, ringless, triplex ground, hub opening	UTRS202BCH	U7021-RL-TG
200 A, OH, ringless, triplex ground, hub cover plate	UTRS202CCH	U7021-XL-TG
200 A, OH, ringless, triplex ground, hub opening, horn bypass	UHTRS202BCH	U7021-RL-TG-KK
200 A, OH, ringless, triplex ground, hub cover plate, horn bypass	UHTRS202CCH	U7021-RL-TG-KK
200 A, OH, ringless, triplex ground, hub opening, fifth terminal	UGTRS202BCH	U7021-RL-TG-5T
200 A, OH, ringless, triplex ground, hub cover plate, fifth terminal	UGTRS202CCH	U7021-XL-TG-5T
200 A, OH, ringless, triplex ground, hub opening, horn bypass, fifth terminal	UGHTRS202BCH	U7021-RL-TG-KK-5T
200 A, OH, ringless, triplex ground, hub cover plate, horn bypass, fifth terminal	UGHTRS202CCH	U7021-RL-TG-KK-5T
200 A, OH/UG, ringless, triplex ground, hub opening, 250 kcmil lugs	UTRS212BCH	No cross (no 250 kcmil lugs)
200 A, OH/UG, ringless, triplex ground, hub cover plate, 250 kcmil lugs	UTRS212CCH	No cross (no 250 kcmil lugs)
200 A, OH/UG, ringless, triplex ground, hub opening, horn bypass, 250 kcmil lugs	UHTRS212BCH	No cross (no 250 kcmil lugs)
200 A, OH/UG, ringless, triplex ground, hub cover plate, horn bypass, 250 kcmil lugs	UHTRS212CCH	No cross (no 250 kcmil lugs)
200 A, OH/UG, ringless, triplex ground, hub opening, fifth terminal, 250 kcmil lugs	UGTRS212BCH	No cross (no 250 kcmil lugs)
200 A, OH/UG, ringless, triplex ground, hub cover plate, fifth terminal, 250 kcmil lugs	UGTRS212CCH	No cross (no 250 kcmil lugs)
200 A, OH/UG, ringless, triplex ground, hub opening, horn bypass, fifth terminal, 250 kcmil lugs	UGHTRS212BCH	No cross (no 250 kcmil lugs)
200 A, OH/UG, ringless, triplex ground, hub cover plate, horn bypass, fifth terminal, 250 kcmil lugs	UGHTRS212CCH	No cross (no 250 kcmil lugs)
200 A, OH/UG, ringless, triplex ground, hub opening, 350 kcmil lugs	UTRS213BE	U7040-RL-TG
200 A, OH/UG, ringless, triplex ground, hub cover plate, 350 kcmil lugs	UTRS213CE	U7040-XL-TG
200 A, OH/UG, ringless, triplex ground, hub opening, horn bypass, 350 kcmil lugs	UHTRS213BE	U7040-RL-TG-KK
200 A, OH/UG, ringless, triplex ground, hub cover plate, horn bypass, 350 kcmil lugs	UHTRS213CE	U7040-XL-TG-KK
200 A, OH/UG, ringless, triplex ground, hub opening, fifth terminal, 350 kcmil lugs	UGTRS213BE	U7040-RL-TG-5T
200 A, OH/UG, ringless, triplex ground, hub cover plate, fifth terminal, 350 kcmil lugs	UGTRS213CE	U7040-XL-TG-5T
200 A, OH/UG, ringless, triplex ground, hub opening, horn bypass, fifth terminal, 350 kcmil lugs	UGHTRS213BE	U7040-RL-TG-KK-5T
200 A, OH/UG, ringless, triplex ground, hub cover plate, horn bypass, fifth terminal, 350 kcmil lugs	UGHTRS213CE	U7040-XL-TG-KK-5T
200 A, UG, ringless, triplex ground, solid top	UTRS223ACH	U1980-0-TG
200 A, UG, ringless, triplex ground, solid top, horn bypass	UHTRS223ACH	U1980-0-TG-KK
200 A, UG, ringless, triplex ground, solid top, fifth terminal	UGTRS223ACH	U1980-0-TG-5T
200 A, UG, ringless, triplex ground, solid top, horn bypass, fifth terminal	UGHTRS223ACH	U1980-0-TG-KK-5T

# 4.1

## Metering Products

### Meter Sockets

#### Lever Bypass

4

Description	Manufacturer	
	Eaton Part Number	Milbank Part Number
200 A, OH, lever bypass, 4 terminal, small hub opening	UTE4203BCH	U9800-RL
200 A, OH, lever bypass, 4 terminal, hub cover plate	UTH4203CCH	U9800-XL
200 A, OH, lever bypass, 4 terminal, large hub opening	UTH4203TCH	U9800-R
200 A, OH, lever bypass, 4 terminal, large hub cover plate	UTH4203UCH	U9800-X
200 A, OH, lever bypass, 5 terminal, small hub opening	UTE5203BCH	U4550-RL
200 A, OH, lever bypass, 5 terminal, hub cover plate	UTH5203CCH	U4550-XL
200 A, OH, lever bypass, 5 terminal, large hub opening	UTH5203TCH	U9559-R
200 A, OH, lever bypass, 5 terminal, large hub cover plate	UTH5203UCH	U9550-X
200 A, OH, lever bypass, 7 terminal, small hub opening	UTE7203BCH	U4701-RL
200 A, OH, lever bypass, 7 terminal, hub cover plate	UTH7203CCH	U4701-XL
200 A, OH, lever bypass, 7 terminal, large hub opening	UTE7203TCH	U4701-R
200 A, OH, lever bypass, 7 terminal, large hub cover plate	UTH7203UCH	U4701-X
200 A, OH/UG, lever bypass, 4 terminal, small hub opening	UTE4213BCH	U9801-RL
200 A, OH/UG, lever bypass, 4 terminal, hub cover plate	UTE4213CCH	U9801-XL
200 A, OH/UG, lever bypass, 4 terminal, large hub opening	UTE4213TCH	U9801-R
200 A, OH/UG, lever bypass, 4 terminal, large hub cover plate	UTH4213UCH	U9801-XL
200 A, OH/UG, lever bypass, 4 terminal, large hub opening with adapter plate	UTE4213ZCH	U9801-RRL
200 A, OH/UG, lever bypass, 4 terminal, large hub opening with adapter and cover plate	UTH4213YCH	U9801-RXL
200 A, OH/UG, lever bypass, 5 terminal, small hub opening	UTE5213BCH	U4551-RL
200 A, OH/UG, lever bypass, 5 terminal, hub cover plate	UTE5213CCH	U4551-XL
200 A, OH/UG, lever bypass, 5 terminal, large hub opening	UTE5213TCH	U9551-R
200 A, OH/UG, lever bypass, 5 terminal, large hub cover plate	UTH5213UCH	U9551-X
200 A, OH/UG, lever bypass, 5 terminal, large hub opening with adapter plate	UTE5213ZCH	U9551-RRL or U4551-RRL
200 A, OH/UG, lever bypass, 5 terminal, large hub opening with adapter and cover plate	UTH5213YCH	U9551-RXL or U4551-RXL
200 A, OH/UG, lever bypass, 7 terminal, small hub opening	UTE7213BCH	U9701-RL or U4701-RL
200 A, OH/UG, lever bypass, 7 terminal, hub cover plate	UTE7213CCH	U9701-XL or U4701-XL
200 A, OH/UG, lever bypass, 7 terminal, large hub opening	UTE7213TCH	U9701-R or U4701-R
200 A, OH/UG, lever bypass, 7 terminal, large hub cover plate	UTE7213UCH	U9701-RX or U4701-RX
200 A, OH/UG, lever bypass, 7 terminal, large hub opening with adapter plate	UTE7213ZCH	U9701-RRL or U4701-RRL
200 A, OH/UG, lever bypass, 7 terminal, large hub opening with adapter and cover plate	UTH7213YCH	U9701-RXL or U4701-RXL
320 A, OH, lever bypass, 4 terminal, large hub opening	UTH4300TCH	U1079-R or U1797-R
320 A, OH, lever bypass, 4 terminal, large hub cover plate	UTH4300UCH	U1079-X or U1797X
320 A, OH/UG, lever bypass, 4 terminal, large hub opening	UTH4330TCH	U2448-R or U2124-R
320 A, OH/UG, lever bypass, 4 terminal, large hub cover plate	UTH4330UCH	U2448-RX or U2124-RX
320 A, OH, lever bypass, 7 terminal, large hub opening	UTH7300TCH	—
320 A, OH, lever bypass, 7 terminal, large hub cover plate	UTH7300UCH	—
320 A, OH/UG, lever bypass, 7 terminal, large hub opening	UTH7330TCH	U2120-R
320 A, OH/UG, lever bypass, 7 terminal, large hub cover plate	UTH7330UCH	U2120-X

**Dimensions**

Approximate Dimensions in Inches (mm)

**Instrument Rated Sockets**

<b>Catalog Number</b>	<b>Height</b>	<b>Width</b>	<b>Depth</b>
<b>USTH131A123CH</b>	20.00 (304.8)	12.00 (304.8)	4.36 (110.7)
<b>USTS131B102CH</b>	20.00 (304.8)	12.00 (304.8)	4.36 (110.7)
<b>USTS132B101CH</b>	20.00 (304.8)	12.00 (304.8)	4.36 (110.7)
<b>USTS132CCH</b>	20.00 (304.8)	12.00 (304.8)	4.36 (110.7)
<b>1008694ACH</b>	20.00 (304.8)	12.00 (304.8)	4.36 (110.7)
<b>1008695ACH</b>	20.00 (304.8)	12.00 (304.8)	4.36 (110.7)
<b>1007003BCH</b>	N/A	N/A	N/A
<b>1007003CCH</b>	16.50 (419.1)	14.00 (355.6)	3.50 (88.9)
<b>USTL131207CH</b>	20.00 (304.8)	12.00 (304.8)	4.35 (110.5)
<b>USTS131BCH</b>	20.00 (304.8)	12.00 (304.8)	4.35 (110.5)
<b>USTS131L143CH</b>	20.00 (304.8)	12.00 (304.8)	4.35 (110.5)
<b>USTS132BCH</b>	N/A	N/A	N/A
<b>USTS61B138CH</b>	20.00 (304.8)	12.00 (304.8)	4.35 (110.5)
<b>UST61BCH</b>	20.00 (304.8)	12.00 (304.8)	4.35 (110.5)
<b>USTS82B166CH</b>	20.00 (304.8)	12.00 (304.8)	4.35 (110.5)
<b>1007361BCH</b>	16.50 (419.1)	14.00 (355.6)	3.50 (88.9)
<b>1008539CH</b>	N/A	N/A	N/A
<b>UASTS131C226CH</b>	20.00 (304.8)	12.00 (304.8)	4.35 (110.5)
<b>1004671CH</b>	17.00 (431.8)	10.00 (254.0)	5.00 (127.0)
<b>ULTS131CCH</b>	22.00 (558.8)	12.00 (304.8)	4.94 (125.5)



#### Residential Pedestals



4

#### Contents

<i>Description</i>	<i>Page</i>
Single Meter Sockets . . . . .	<b>V1-T4-2</b>
Commercial Lever Bypass Sockets . . . . .	<b>V1-T4-10</b>
Multiple Position Horizontal Ganged Sockets . . . . .	<b>V1-T4-17</b>
Instrument Rated Sockets . . . . .	<b>V1-T4-23</b>
Residential Pedestals	
Product Selection . . . . .	<b>V1-T4-29</b>
Dimensions . . . . .	<b>V1-T4-29</b>
Meter Socket Accessories . . . . .	<b>V1-T4-30</b>

#### Residential Pedestals

##### Product Description

- Available in 100 A, 200 A, 300 A and 320 A designs
- Available in 4- or 5-jaw configurations
- Underground service design is standard
- Bypass options (lever, horn) are available
- Solid top designs

Product Selection

UHTRP242363CH



Residential Pedestals

Ampere Rating	Jaws	Service	Bypass	Connections Line	Load	Opening, Hub or Closure Plate	Catalog Number
320	4	UG	—	3/8-inch studs	3/8-inch studs	Solid top	1008847CH
320	4	UG	Lever	#6–350 kcmil line and line neutral	2/0–250 kcmil load and load neutral	Solid top	1009017CH <sup>①</sup>
300	4	UG	Lever	#6–350 kcmil line and line neutral	2/0–250 kcmil load and load neutral	Solid top	—
200	4	UG	Horn	4/0 compression (line) 2/0 compression (neutral)	#6–250 kcmil load and load neutral	Solid top	1006388CH
200	4	UG	Horn	#8–350 kcmil	#8–350 kcmil	Solid top	UHTRP242363CH
200	4	UG	Horn	#6–350 kcmil line and line neutral	#6–250 kcmil load neutral	Solid top	1008846CH
200	4	UG	Horn	#6–350 kcmil line and line neutral	#6–250 kcmil load neutral	N/A	1008961CH
200	5	N/A	N/A	N/A	N/A	N/A	1008966CH
200	4	UG	—	#6–350 kcmil line and line neutral	#6–350 kcmil load and load neutral	Solid top	1009264CH
200	4	UG	—	4/0 compression (line) 2/0 compression (neutral)	#6–350 kcmil load and load neutral	Solid top	1009265CH
100	4	UG	—	#6–350 kcmil line and line neutral	#6–250 kcmil load neutral	Solid top	1009078CH

Dimensions

Approximate Dimensions in Inches (mm)

Residential Pedestals

Catalog Number	Height	Width	Depth
1008847CH	58.00 (1473.2)	12.97 (329.4)	4.93 (125.2)
1009017CH <sup>①</sup>	63.00 (1600.2)	12.96 (329.2)	4.93 (125.2)
1006388CH	61.00 (1549.4)	8.96 (227.6)	4.93 (125.2)
UHTRP242363CH	62.63 (1590.8)	8.97 (227.8)	4.94 (125.5)
1008846CH	70.00 (1778.0)	11.00 (279.4)	6.00 (152.4)
1008961CH	69.93 (1776.2)	N/A	6.00 (152.4)
1008966CH	N/A	N/A	N/A
1009264CH	74.00 (1879.6)	8.96 (227.6)	4.93 (125.2)
1009265CH	74.00 (1879.6)	8.97 (227.8)	4.94 (125.5)
1009078CH	69.93 (1776.2)	11.00 (279.4)	6.00 (152.4)

Note

<sup>①</sup> 200 A breakers.

# 4.1

## Metering Products

### Meter Sockets

4

#### Meter Socket Accessories



#### Contents

<i>Description</i>	<i>Page</i>
Single Meter Sockets .....	<b>V1-T4-2</b>
Commercial Lever Bypass Sockets .....	<b>V1-T4-10</b>
Multiple Position Horizontal Ganged Sockets .....	<b>V1-T4-17</b>
Instrument Rated Sockets .....	<b>V1-T4-23</b>
Residential Pedestals .....	<b>V1-T4-28</b>
Meter Socket Accessories	
Cross-Reference .....	<b>V1-T4-25</b>
Product Selection .....	<b>V1-T4-31</b>
Mechanical Lugs .....	<b>V1-T4-33</b>
Communications Grounding Device (NEC 250.94) .....	<b>V1-T4-34</b>
Wiring Diagram .....	<b>V1-T4-34</b>

#### Meter Socket Accessories

##### Features and Benefits

##### Construction Features



1. High strength, glass-filled meter block assembly, lay-in connectors with captive slide nut and screw.



2. 100% plated copper alloy meter jaw with reinforcing spring clip and meter guide.



3. Extruded neutral lug with integral triplex ground and quadplex ground provision.

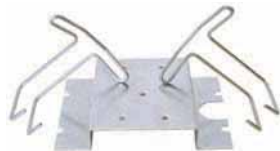

4. Bridge and meter supports are 100% zinc chromate plated.

#### 200 A Ringless Block Assembly With Horn Bypass

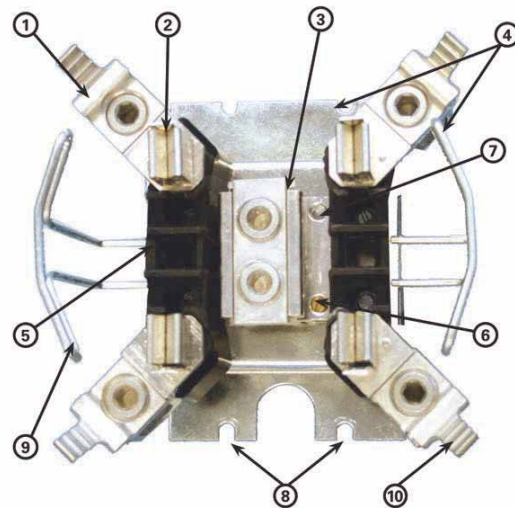

5. Fifth terminal locating hole in 9 o'clock position.
6. Triplex ground is a standard feature.
7. Quadplex ground provision.
8. Durable "four-point" bridge mounting (2 top, 2 bottom).
9. Extra rigid meter support for ringless sockets.
10. Optional, integral horn bypass extruded on slide nut. Horn is ribbed for secure attachment to utility bypass jumpers. Field-installable horn bypass kit available.

## Product Selection

### Meter Socket Accessories

Description	Part Number
<b>Hub Closure Plates</b>	
Hub closure plate meter socket accessories	ARP00002CHB
Clam shell hub closure plate meter socket accessories	ARP00002CHBCS
1-inch hub closure plate meter socket accessories	ARP00003CH1
Clam shell 1-inch hub closure plate—small opening	ARP00003CH1CS
1-1/4-inch hub closure plate meter socket accessories	ARP00004CH12
Clam shell 1-1/4-inch hub closure plate—small opening	ARP00004CH12CS
1-1/2-inch hub closure plate meter socket accessories	ARP00005CH15
Clam shell 1-1/2-inch hub closure plate—small opening	ARP00005CH15CS
2-inch hub closure plate meter socket accessories	ARP00006CH2
Aluminum hub closure plate for single sockets	ARP00008CH
Large hub cover plate	ARP00016CHB
<b>Hubs</b>	
2-inch hub with large diameter opening	ARP00017CH2
2-1/2-inch hub for meter socket accessories	ARP00007CH25
Clam shell 2-1/2-inch hub for meter socket accessories	ARP00007CH25CS
2.5-inch hub with large diameter opening	ARP00018CH25
3-inch hub	ARP00019CH3
3-1/2-inch hub for meter sockets	ARP00020CH35
4-inch hub	ARP00021CH4
Hub adapter from large opening to small opening	ARP00015CHAP
<b>Lug Kits</b>	
(2) #6–250 kcmil, double barrel lug for 4, 5 and 7 terminal 3/8-inch stud sockets	ARP00118CH
#4–600 or (2) 1/0–250 kcmil, single barrel lug for 4, 5 and 7 terminal 3/8-inch stud sockets	ARP00429CH
#6–350 kcmil, single barrel lug for 4, 5 and 7 terminal 3/8-inch stud sockets	ARP00119CH
#4–600 kcmil, single barrel lug for 4, 5 and 7 terminal 3/8-inch stud sockets	ARP00129CH
(2) #6–350 kcmil, double barrel lug for 4 terminal 3/8-inch stud sockets	ARP00427CH
<b>Miscellaneous</b>	
Screw sealing ring for single meter sockets	ARP00027CH
Fifth jaw kit	ARP00035CHJ
Fifth jaw for bolt on meter	ARP00326CH
Neutral insulating kit for lever bypass sockets only	ARP00759CH
100 A meter socket horn cap assembly kit	ARP00777CH
Fifth jaw kit for 320 A offset socket	ARP00862CH
HQ anti-inversion clip for single meter sockets	ARP00984CH
Fifth jaw for Chicago and Wisconsin pedestal	ARP01085CH
350 kcmil BNS cap assembly kit for meter sockets	ARP01226CH
Right hand block assembly with Z Bar	ARP01258CH
Left hand block assembly with Z Bar	ARP01414CH
Meter pack trough closure plate kit	ARP01565CH
2/0 connector kit for MBB and MBP socket breaker	ARP01612CH

## Hub Accessories

Description	Manufacturer	
	Eaton Part Number	Milbank Part Number
Small hub cover plate	ARP00002CHB	A7551
1-inch hub	ARP00003CH1	A7514
1-1/4-inch hub	ARP00004CH12	A7515
1-1/2-inch hub	ARP00005CH15	A7516
2-inch hub	ARP00006CH2	A7517
2-1/2-inch hub	ARP00007CH25	A7518
3-inch hub	ARP00019CH3	A8110
3-1/2-inch hub	ARP00020CH35	A8111
4-inch hub	ARP00021CH4	A8112
Large to small hub opening adapter plate	ARP00015CHAP	S8324
Large hub cover plate	ARP00016CHB	S9064

## Residential Pedestal Extension Kits

Connections			Approximate Dimensions in Inches (mm)		
Line	Load	Catalog Number	Height	Width	Depth
Pedestal extension kit for 1008846CH	Pedestal extension kit for 1008846CH	1009021CH	18.00 (457.2)	11.00 (279.4)	6.00 (152.4)
		1009022CH	18.00 (457.2)	12.96 (329.2)	4.93 (125.2)
		1009026CH	30.00 (762.0)	12.96 (329.2)	4.93 (125.2)

## Mechanical Lugs



### Product Description

- Single lug
- Extended tang single lug
- Extended tang triple lug
- Double lug
- Extended tang double lug
- Extended tang quadruple lug

### Product Selection

#### Mechanical Lugs

Description	Style Number
Single #14–#6 mechanical lug	<b>ESL146</b>
Single #14–2/0 mechanical lug	<b>ESL1420</b>
Single #6–250 kcmil mechanical lug	<b>ESL6250</b>
Single #4–500 kcmil mechanical lug	<b>ESL4500</b>
Double #14–2/0 mechanical lug	<b>EDL1420</b>
Double #6–250 kcmil mechanical lug	<b>EDL6250</b>
Extended tang single lug #6–350 kcmil	<b>EPBSL6350</b>
Extended tang single lug 300–800 kcmil	<b>EPBSL300800</b>
Extended tang double lug #6–350 kcmil	<b>EPBDL6350</b>
Extended tang double lug 300–800 kcmil	<b>EPBDL300800</b>
Extended tang triple lug #6–350 kcmil	<b>EPBTL6350</b>
Extended tang triple lug 300–800 kcmil	<b>EPBTL300800</b>
Extended tang quadruple lug #6–350 kcmil	<b>EPBQL6350</b>
Extended tang quadruple lug 300–750 kcmil	<b>EPBQL300800</b>
Extended tang single lug #2–600 kcmil	<b>EPBSL2600</b>
Extended tang single lug 500–1000 kcmil	<b>EPBSL5001000</b>
Extended tang triple lug #2–600 kcmil	<b>EPBTL2600</b>

### Dimensions

#### Mechanical Lugs

##### Approximate Dimensions in Inches (mm)

Style Number	Height	Width	Length
<b>ESL146</b>	2.50 (63.5)	8.25 (82.6)	3.50 (88.9)
<b>ESL1420</b>	2.50 (63.5)	10.50 (266.7)	3.50 (88.9)
<b>ESL6250</b>	2.50 (63.5)	10.50 (266.7)	3.50 (88.9)
<b>ESL4500</b>	2.50 (63.5)	10.50 (266.7)	3.50 (88.9)
<b>EDL1420</b>	3.50 (88.9)	4.00 (101.6)	3.50 (88.9)
<b>EDL6250</b>	3.50 (88.9)	3.75 (95.3)	4.50 (114.3)
<b>EPBSL6350</b>	2.50 (63.5)	8.25 (82.6)	3.50 (88.9)
<b>EPBSL300800</b>	2.50 (63.5)	10.50 (266.7)	3.50 (88.9)
<b>EPBDL6350</b>	3.50 (88.9)	4.50 (114.3)	5.50 (139.7)
<b>EPBDL300800</b>	3.00 (76.2)	10.50 (266.7)	5.50 (139.7)
<b>EPBTL6350</b>	3.50 (88.9)	4.50 (114.3)	5.50 (139.7)
<b>EPBTL300800</b>	2.50 (63.5)	10.00 (254.0)	5.75 (146.0)
<b>EPBQL6350</b>	2.25 (57.2)	6.50 (165.1)	6.00 (152.4)
<b>EPBQL300800</b>	4.25 (108.0)	8.50 (215.9)	8.50 (215.9)
<b>EPBSL2600</b>	2.50 (63.5)	8.25 (82.6)	3.50 (88.9)
<b>EPBSL5001000</b>	2.50 (63.5)	10.50 (266.7)	3.50 (88.9)
<b>EPBTL2600</b>	2.25 (57.2)	6.50 (165.1)	6.00 (152.4)

# 4.1

## Metering Products

### Meter Sockets

4

#### Communications Grounding Device (NEC 250.94)



#### Features, Benefits and Functions

##### Communication Grounding Device Features

- Lay-in lug for ease of installation
- Four bonding terminals
- Heavy-duty zinc-plated steel screws included
- Two mounting holes to securely hold device into place
- For use with copper and aluminum conductors

##### Cover Features

- Outdoor rated reinforced glass polyester compound
- Suitable for UV exposure
- Paintable exterior, allowing for matching of exterior of home

#### Product Description

This product is required per the 2008 NEC Article 250.94 "Bonding for Other Systems."

This product is applied externally to residential homes, so that communications systems devices such as satellite, TV, cable and CATV can be properly bonded at a single point. This device has two mounting holes that can be used for easy installation.

#### Standards and Certifications

- ETL listed

#### Product Selection

##### Communication Grounding Device

##### Wire Range

Bonding Conductor	Ground Electrode	Quantity	Catalog Number
#14-#2-STR-SOL-CU #12-#2-SRT-SOL-AL	#8-1/0-STR-SOL-CU/AL	(1) Clamshell	<b>MSEGR2CS</b>
#14-#2-STR-SOL-CU #12-#2-SRT-SOL-AL	#8-1/0-STR-SOL-CU/AL	(10) Bulk pack	<b>MSEGR2</b>

#### Dimensions

Approximate Dimensions in Inches (mm)

##### Communication Grounding Device

Catalog Number	Length	Width	Height
<b>MSEGR2CS</b>	0.75 (19.1)	3.90 (99.1)	1.20 (30.5)
<b>MSEGR2</b>	0.75 (19.1)	3.90 (99.1)	1.20 (30.5)

#### Wiring Diagram

##### Installation and Configuration

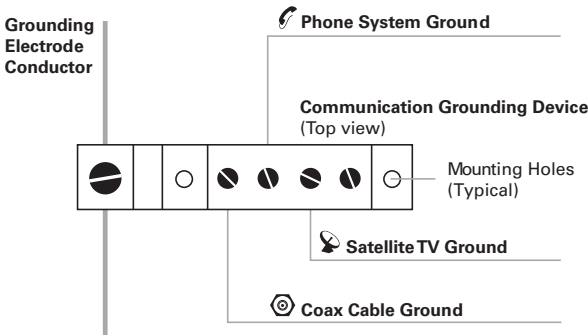
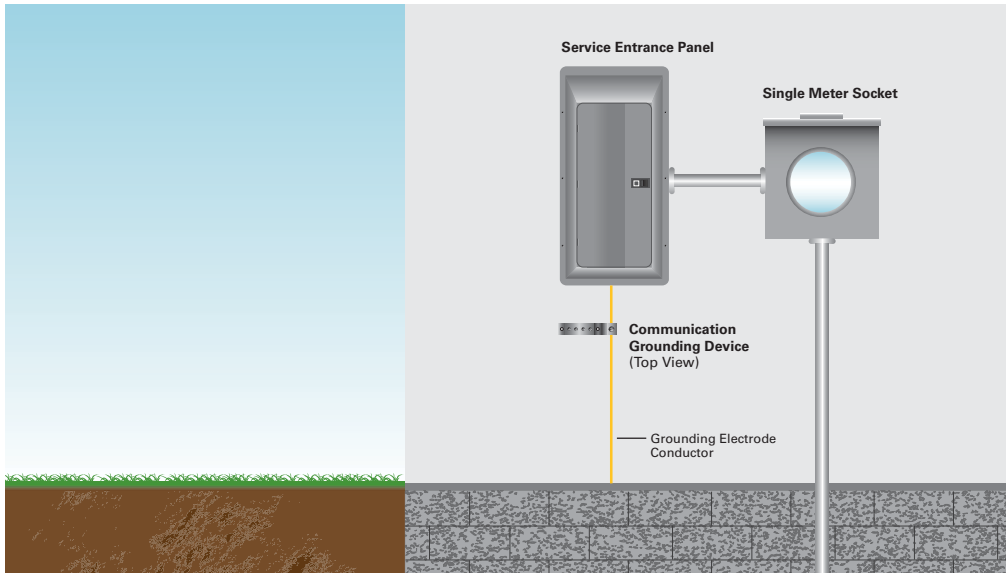

Residential Meter Breakers



Contents

<i>Description</i>	<i>Page</i>
Residential Meter Breakers	
Standards and Certifications . . . . .	<b>V1-T4-36</b>
Technical Data and Specifications . . . . .	<b>V1-T4-36</b>
Non-EUSERC Combination Service Entrance Devices 100–200 A Styles . . . . .	<b>V1-T4-37</b>
EUSERC Required Service Entrance Devices 100–225 A . . . . .	<b>V1-T4-41</b>
West Coast All-In-One Design . . . . .	<b>V1-T4-44</b>
House Panels . . . . .	<b>V1-T4-48</b>
Aluminum Meter Breakers . . . . .	<b>V1-T4-53</b>
CH Style Renovation Solutions . . . . .	<b>V1-T4-54</b>
Commercial Safety Sockets . . . . .	<b>V1-T4-55</b>
Meter Breakers Accessories . . . . .	<b>V1-T4-58</b>

Residential Meter Breakers

Product Description

A meter breaker is service entrance equipment that consists of a single meter socket and loadcenter (circuit breaker distribution section) or meter socket and main breaker combined in one enclosure. Sometimes called Combos, All-in-Ones, Meter Centers or Meter Mains, these units are increasing in popularity as the socket and loadcenter or main breaker are located in one location, thus providing the contractor with a labor and material savings when installing.

Application Description

In addition to residential installations, meter breakers are equally applicable for rural service entrance, mobile homes and construction site temporary power. Meter breakers are most often sold in the western, southwestern and southeastern United States. The popularity of meter breakers is continuing to increase as more utilities deregulate and pass the responsibility of supplying wathour meter sockets on to the electrical contractor.

Application Considerations

Eaton has the meter breaker to meet your application, offering:

- Non-EUSERC
- EUSERC/West Coast
- House panels
- Commercial safety socket

Non-EUSERC (Page V1-T4-37)

Eaton’s line of non-EUSERC meter breakers are designed for customers served by utilities that are not members of EUSERC.

EUSERC/West Coast (Page V1-T4-44)

Eaton’s line of EUSERC required devices adhere to the agreed upon standards. EUSERC utilities are predominately located in the western United States, but some eastern and midwestern utilities are also members. These units can also be used in many Non-EUSERC areas.

House Panels (Page V1-T4-48)

CH and BR Styles (Page V1-T4-49).

Meter breaker device rated at 300–400 A. Applied in EUSERC and non-EUSERC areas.

Commercial Safety Sockets (Page V1-T4-55)

Applied in EUSERC and non-EUSERC service areas and used in commercial applications.

Features, Benefits and Functions

- Both Type BR and CH branch circuit breaker styles available
- Meets latest NEC wire bending space requirements
- Slotted sealing screws at hub with sealing provision provided
- Surface units are supplied with mounting tabs
- Semi-flush units are supplied with stucco flange
- Meter socket ring landing will accept locking security rings
- Overhead or underground service
- Fifth jaw can be installed in the 3 o’clock or 9 o’clock position
- Semi-flush with nail flange or surface mounting
- Meter mounting and underground pull sections are utility sealable
- Units are rated a minimum of 10 kAIC; some units are 22 kAIC
- Numerous units supplied with center keyhole for ease of mounting
- NEMA 3R rainproof construction



**Standards and Certifications**

- UL Specification 414 (socket)
- UL File Number E52977
- AEIC-EEI-NEMA Standards (MSJ-7)
- Meet EUSERC utility requirements where noted
- Documented seismic qualified—UBC and CBC Title 24
- UL Specification 67 (panel)

**Technical Data and Specifications**

- Ratings single-phase, three-wire, 120/240 Vac
- 100–225 A main breaker and main lug types
- 10,000 A rms symmetrical short-circuit rating
- Available kAIC ratings: 10 k with BW breaker, 22 k with CSR breaker and 35 k with CSH breaker

Consult TD.31F.01.T.E for dimensions, wiring diagrams and knockouts.

Non-EUSERC Combination Service Entrance Devices



Standard Design Non-EUSERC Panel

Compact Design

Non-EUSERC Combination Service Entrance Devices

Product Description

A device that may include a meter socket, main breaker and loadcenter section within the same enclosure.

- Meter main = meter socket and main breaker
- Meter breaker = meter socket, main breaker and loadcenter section

Application Description

Eaton’s line of non-EUSERC meter breakers are designed for customers served by utilities that are not members of EUSERC.

Contents

<i>Description</i>	<i>Page</i>
Residential Meter Breakers .....	V1-T4-35
Non-EUSERC Combination Service Entrance Devices 100–200 A Styles	
Catalog Number Selection .....	V1-T4-38
Product Selection .....	V1-T4-38
EUSERC Required Service Entrance Devices 100–225 A .....	V1-T4-41
West Coast All-In-One Design .....	V1-T4-44
House Panels .....	V1-T4-48
Aluminum Meter Breakers .....	V1-T4-53
CH Style Renovation Solutions .....	V1-T4-54
Commercial Safety Sockets .....	V1-T4-55
Meter Breakers Accessories .....	V1-T4-58

Features, Benefits and Functions

**Meter Mains and All-in-Ones**

- Single-phase, three-wire, 120/240 Vac, 10 kAIC
- Larger lay-in lugs and 3-inch (76.2 mm) knockouts for ease of installation
- Box-type main lugs included
- Factory-installed neutral
- Hub provisions on top endwall. If hubs are required, order “DS” style
- Ring, ringless and ringless with horn bypass styles available
- Ringless style, provided with embossed covers and security latch for utility company lock
- Padlockable device covers provide additional measure of safety and help prevent tampering
- NEMA 3R rainproof construction

**Meter Mains**

- Meter socket and main breaker
- Stainless steel latches on meter compartments in MBP types
- No distribution section included

**All-in-Ones**

- Meter socket and loadcenter distribution section
- Stainless steel latches on meter compartments
- Several designs with horn bypass and fifth jaw
- Center-fed main breaker, lugs or provision
- Uses Type BR 1-inch (25.4 mm) wide branch breakers
- Special channel for top exit

# 4.2

## Metering Products

### Meter Breakers

4

#### Catalog Number Selection

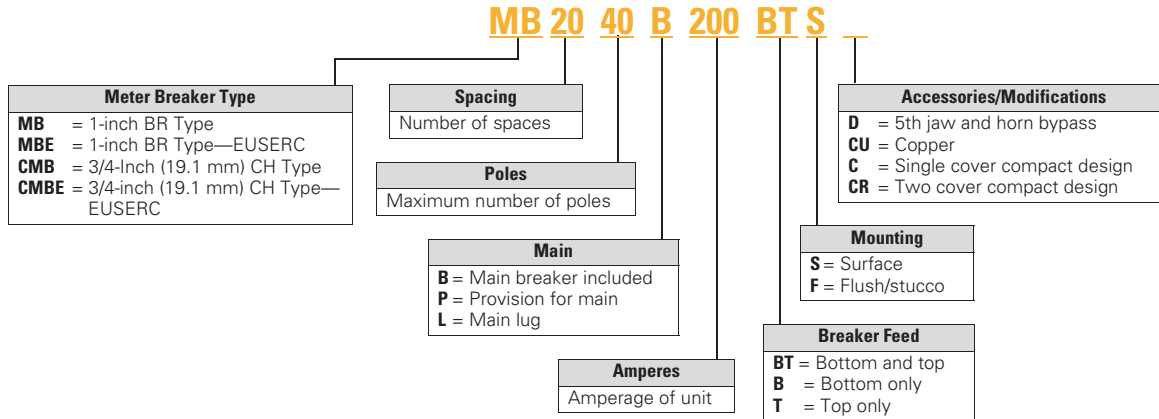

#### Product Selection

##### Main Breaker Selection Chart

Maximum Ampere Rating	Two-Pole Breaker Catalog Numbers			
	10 kAIC	25 kAIC	25 kAIC	35 kAIC
100	<b>BW2100</b>	<b>CSR2100</b>	<b>CSR2100N</b>	<b>CSH2100N</b>
125	<b>BW2125</b>	<b>CSR2125</b>	<b>CSR2125N</b>	<b>CSH2125N</b>
150	<b>BW2150</b>	<b>CSR2150</b>	<b>CSR2150N</b>	<b>CSH2150N</b>
200	<b>BW2200</b>	<b>CSR2200</b>	<b>CSR2200N</b>	<b>CSH2200N</b>
Load Side Lug Kit for BW and CSR Breakers ①			<b>MCBK225</b>	

Note: See knockout drawings on Pages V1-T4-61 through V1-T4-67 for hub information.

Ring Style Meter Mains



Combination Service Entrance Devices—Non-EUSERC

Ampere Rating	Bypass	Service	kAIC	Jaws	Distribution	Main	Branch Breaker Type	Dimensions and Enclosure Shape ①	Page Numbers Knockout ①	Catalog Number
<b>Ring Style Meter Mains (no distribution section included)</b>										
150	None	OH/UG	10	4	None	CSR2150	None	13	V1-T4-67	MBB150BTSCR
150	None	OH/UG	22	4	None	CSR2150	None	3	V1-T4-62	CMBB150BTS ⑥⑥
200	None	OH/UG	10	4	None	CSR2200	None	13	V1-T4-67	MBB200BTSCR
200	None	OH/UG	②	4	None	Provision ③	None	3	V1-T4-62	CMBP200BTS ⑥⑥
200	None	OH/UG	22	4	None	CSR2200	None	3	V1-T4-62	CMBB200BTS ⑥⑥
<b>Ringless Meter Mains (no distribution section included)</b>										
150	None	OH/UG	10	4	None	CSR2150	None	13	V1-T4-67	MBB150BTSC ⑥
200	None	OH/UG	10	4	None	CSR2200	None	9	V1-T4-67	MBB200BTS ⑦
200	None	OH/UG	10	4	None	CSR2200	None	13	V1-T4-67	MBB200BTSC ⑥
150	None	OH/UG	10	4	None	CSR2125	None	9	V1-T4-67	MBB150BTS
200	None	OH/UG	②	4	None	Provision ④	None	9	V1-T4-67	MBP200BTS ⑥
200	Horn	OH/UG	②	5	None	Provision ④	None	11	V1-T4-67	MBP200SD
200	Horn	OH/UG	②	5	None	Provision ④	None	9	V1-T4-67	MBP200BTSD
100	Horn	OH/UG	10	5	None	Provision	None	15	V1-T4-67	CHMMB100BTS
150	Horn	OH/UG	10	5	None	CSR2150	None	16	V1-T4-67	CHMMB150BTS
200	Horn	OH/UG	10	5	None	CSR2200	None	16	V1-T4-67	CHMMB200BTS
150	None	OH/UG	10	4	4/8	CSR	BR	—	—	MB48B150TSG
200	None	OH/UG	10	4	4/8	CSR	BR	—	—	MB48B200BTSG
200	Lever	OH/UG	22	4	8/16	CSR	BR	—	—	MBX816B200BTS ⑥
200	Lever	OH/UG	22	4	20/40	CSR	BR	—	—	MBX2040B200BTS ⑥

Ringless Meter Mains



Notes

- ① See Page V1-T4-61 for box details.
- ② Per installed main breaker rating.
- ③ When a provision for main is provided, order one of the main breakers listed in this table. Panels are labeled to accept Type CSR Main Breakers.
- ④ When a provision for main is provided, order one of the main breakers listed in Page V1-T4-38. Panels are dual labeled to accept Types BW, CSR or CSH Main Breakers.
- ⑥ Copper bus.
- ⑦ One-piece cover on utility side, Florida approved.
- ⑧ Single cover design.
- ⑨ Approved by Xcel Energy Inc.

Note: See knockout drawings on Pages V1-T4-61 through V1-T4-67 for hub information.

#### Ring Style All-in-Ones



4

#### Combination Service Entrance Devices—Non-EUSERC, continued

Ampere Rating	Bypass	Service	kAIC	Jaws	Distribution	Main	Branch Breaker Type	Dimensions and Enclosure Shape ①	Page Numbers	Knockout ①	Catalog Number
<b>Ring Style All-in-Ones (includes distribution section)</b>											
125	None	OH/UG	②	4	2/4	None—refer to Distribution CSR2150	CH	2	V1-T4-62	CMB24L125BTS ④⑤	
150	None	OH/UG	22	4	8		CH	3			V1-T4-62
200	None	OH/UG	10	4	4/8	CSR2200	BR	3	V1-T4-62	MB48B200BTS ⑤⑥	
200	None	OH/UG	22	4	8	CSR2200	CH	3	V1-T4-62	CMB88B200BTS ④⑤⑥	
200	None	UG	22	4	32/42	CSR2200	CH	7	V1-T4-61	CMB3242B200BS ④⑤	
200	None	OH/UG	22	—	42/42	—	CH	—	—	CMB4242B200BTS ④	
<b>Ringless All-in-Ones (includes distribution section)</b>											
125	None	OH/UG	22	4	4/8	CSR2125	BR	21	V1-T4-64	MBT48B125BTS	
150	None	OH/UG	22	4	4/8	CSR2150	BR	21	V1-T4-64	MBT48B150BTS	
150	Horn	OH/UG	10	5	8/16	BW2150	BR	11	—	MB816B150STD	
150	Horn	OH/UG	10	5	20/40	BW2150	BR	11	V1-T4-66	MB2040B150SD	
200	None	OH/UG	10	4	8/16	CSR2200	BR	10	V1-T4-66	MB816B200BTS ⑤⑥	
200	None	OH/UG	10	4	8/16	CSR2200	BR	10	V1-T4-66	MB816B200BTSCU ④⑤⑥	
200	Horn	OH/UG	10	5	8/16	BW2200	BR	11	—	MB816B200STD	
200	None	OH/UG	②	4	8/16	Provision ③	BR	10	V1-T4-66	MB816P200BTS ⑤⑥	
200	None	OH/UG	②	4	8/16	Provision ③	BR	10	V1-T4-66	MB816P200BTSCU ④⑤⑥	
200	Horn	OH/UG	②	5	8/16	Provision ③	BR	11	V1-T4-66	MB816P200STD ⑥	
200	Horn	OH/UG	②	5	8/16	Provision ③	BR	10	V1-T4-66	MB816P200STD ⑥	
200	None	OH/UG	10	4	12/12	CSR2200	CH	10	V1-T4-62	CMB1212B200BTS ④⑤⑥	
200	None	OH/UG	②	4	6–2 Pole	Main lugs	CH	9	V1-T4-63	CMB1212L200BTS ④⑥	
200	None	OH/UG	②	4	12/12	Provision ③	CH	10	V1-T4-63	CMB1212P200BTS ④⑤⑥	
200	None	OH/UG	②	4	6–2 Pole	Main lugs	BR	9	V1-T4-63	MB1212L200BTS ⑥	
200	None	OH/UG	22	4	24/24	CSR2200	CH	10	V1-T4-66	CMB2424B200BTS ④⑤	
200	None	OH/UG	22	4	24/36	CSR2200	CH	10	V1-T4-66	CMB2436B200BTS ④	
200	None	OH/UG	10	4	20/40	CSR2200	BR	10	V1-T4-66	MB2040B200BTS ④	
200	None	OH/UG	②	4	20/40	Provision ③	BR	10	V1-T4-66	MB2040P200BTS ⑤	
200	Horn	OH/UG	②	5	20/40	Provision ③	BR	11	V1-T4-66	MB2040P200SD	
200	Horn	OH/UG	10	5	20/40	CSR2200	BR	10	V1-T4-66	MB2040B200SD	
200	Lever	OH/UG	10	5	None	CSR2200	None	14	V1-T4-65	CMBXB200BTS ④⑦	
200	Lever	OH/UG	10	5	12/12	CSR2200	CH	14	V1-T4-65	CMBX1212B200BTS ④⑥⑦	
200	Lever	OH/UG	10	5	32/42	CSR2200	CH	14	V1-T4-65	CMBX3242B200BTS ④⑦	
200	Lever	OH/UG	10	5	None	Provision	None	14	V1-T4-65	CMBXP200BTS ④⑦	
200	Lever	OH/UG	10	5	12/12	Provision	CH	14	V1-T4-65	CMBX1212P200BTS ④⑥⑦	
200	Lever	OH/UG	10	5	32/42	Provision	CH	14	V1-T4-65	CMBX3242P200BTS ④⑦	
200	None	OH/UG	②	4	4/8	Provision	BR	21	V1-T4-65	MBT48P200BTS ⑥	
200	None	OH/UG	22	4	4/8	CSR2200	BR	21	V1-T4-65	MBT48B200BTS ⑥	

#### Notes

- ① See Page V1-T4-61 for box details.
- ② Per installed main breaker rating.
- ③ When a provision for main is provided, order one of the main breakers listed on Page V1-T4-38. All panels are dual labeled to accept Types BW, CSR, CSH Main Breakers.
- ④ Copper bus.
- ⑤ One-piece cover on utility side, Florida approved.
- ⑥ Units come with feed-through lugs.
- ⑦ Approved by Xcel Energy Inc.

**EUSERC Required Service Entrance Devices**



*Meets EUSERC Requirements Service Entrance Devices 100–225 A*

**Contents**

<i>Description</i>	<i>Page</i>
Residential Meter Breakers .....	<b>V1-T4-35</b>
Non-EUSERC Combination Service Entrance Devices 100–200 A Styles .....	<b>V1-T4-37</b>
EUSERC Required Service Entrance Devices 100–225 A	
Catalog Number Selection .....	<b>V1-T4-42</b>
Product Selection .....	<b>V1-T4-42</b>
West Coast All-In-One Design .....	<b>V1-T4-44</b>
House Panels .....	<b>V1-T4-48</b>
Aluminum Meter Breakers .....	<b>V1-T4-53</b>
CH Style Renovation Solutions .....	<b>V1-T4-54</b>
Commercial Safety Sockets .....	<b>V1-T4-55</b>
Meter Breakers Accessories .....	<b>V1-T4-58</b>

**EUSERC Required Service Entrance Devices**

**Product Description**

Eaton is proud to introduce a new line of West Coast/EUSERC Meter Breaker units. The new EUSERC devices complement the existing standard meter breaker devices. Customers who are interested in the complete meter breaker line of products can refer to Technical Data TD.31F.01.T.E.

**Application Description**

Eaton’s line of EUSERC required devices adhere to the agreed upon standards. EUSERC utilities are predominately located in the western United States, but some eastern and midwestern utilities are also members. **These units can also be used in many Non-EUSERC areas.**

**Features, Benefits and Functions**

- Single-phase, three-wire, 120/240 V, 10 kAIC
- Larger 250 kcmil lugs and additional knockouts for ease of installation
- Box type main lugs are included
- Factory-installed neutrals
- Hub provisions on top endwall. If hubs are required, order “DS” type hubs
- Ring type sockets are provided with a sealing ring
- Padlockable device covers provide an additional measure of security and help prevent tampering
- Most units have center keyhole for easy one-person installation
- NEMA 3R rainproof construction

### Catalog Number Selection

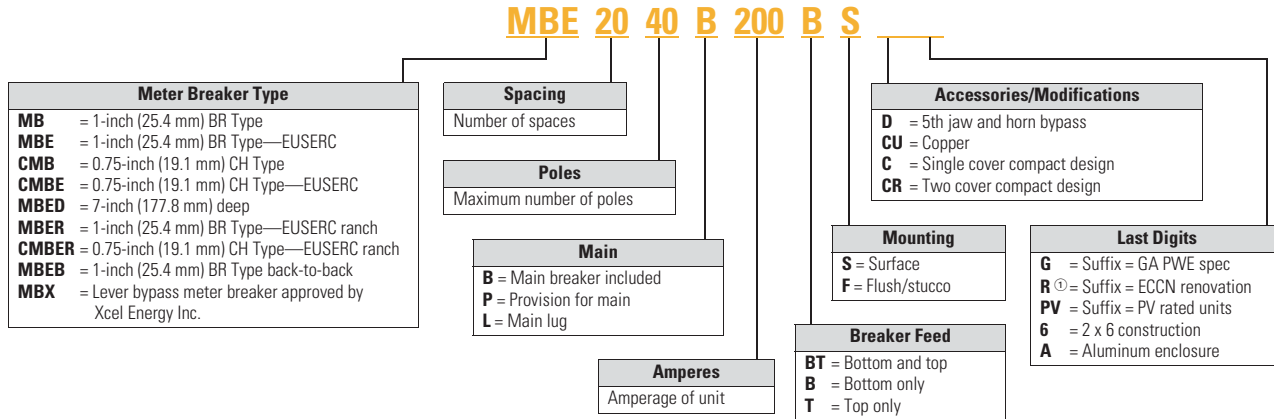

### Product Selection

**Note:** See knockout drawings on **Pages V1-T4-61 through V1-T4-67** for hub information.

### Combination Service Entrance Devices—EUSERC

Ampere Rating	By-pass	Service	kAIC	Jaws	Distribution	Main	Branch Breaker Type	Dimensions and Enclosure Shape <sup>②</sup>	Page Numbers	Catalog Number—Surface	Catalog Number—Flush
<b>Ring Style Meter Mains (no distribution section included)</b>											
125	None	OH/UG	③	4	2/4	MLO	BR	2	<b>V1-T4-62</b>	<b>MBE24L125BTS</b> <sup>④</sup>	<b>MBE24L125BTF</b>
125	None	OH/UG	③	4	2/4	MLO	CH	2	<b>V1-T4-62</b>	<b>CMBE24L125BTS</b> <sup>④⑤</sup>	—
150	None	OH/UG	22	4	None	CSR2150N	None	3	<b>V1-T4-62</b>	<b>CMBE8150BTS</b> <sup>④⑤</sup>	—
200	None	OH/UG	10	4	None	CSR2200	None	3	<b>V1-T4-62</b>	<b>MBE200BTS</b> <sup>④</sup>	<b>MBE200BTF</b>
200	None	OH/UG	22	4	None	CSR2200N	None	3	<b>V1-T4-62</b>	<b>CMBE200BTS</b> <sup>④⑤</sup>	—
200	None	OH/UG	③	4	2/4	MLO	BR	3	<b>V1-T4-62</b>	<b>MBE24L200BTS</b> <sup>④</sup>	<b>MBE24L200BTF</b>
200	None	OH/UG	③	4	2/4	MLO	CH	3	<b>V1-T4-62</b>	<b>CMBE24L200BTS</b> <sup>④⑤</sup>	—
<b>Ring Style All-in-Ones (includes distribution section)</b>											
100	None	OH/UG	10	4	12/24	BR2100	BR	2	<b>V1-T4-62</b>	<b>MBE1224B100BTS</b>	<b>MBE1224B100BTF</b>
100	None	UG	10	4	14/28	BR2100	BR	4	<b>V1-T4-61</b>	<b>MBE1428B100BS</b> <sup>⑥</sup>	<b>MBE1428B100BF</b> <sup>⑥</sup>
100	None	OH	10	4	12/24	BR2100	BR	9	<b>V1-T4-63</b>	<b>MBE1224B100TS</b>	—
125	None	OH/UG	10	4	12/24	BR2125	BR	2	<b>V1-T4-62</b>	<b>MBE1224B125BTS</b>	<b>MBE1224B125BTF</b>
125	None	OH	10	4	12/24	BR2125	BR	9	<b>V1-T4-63</b>	<b>MBE1224B125TS</b>	—
125	None	UG	10	4	18/36	BR2125	BR	5	<b>V1-T4-61</b>	—	<b>MBE1836B125BF</b> <sup>⑥</sup>
150	None	OH/UG	10	4	4/8	CSR2150	BR	19	—	<b>MBER48B150BTS</b> <sup>⑦⑧</sup>	—
150	None	OH/UG	22	4	8/8	CSR2150N	CH	19	—	<b>CMBER88B150BTS</b> <sup>⑤⑦⑧</sup>	—
150	None	OH/UG	22	4	8	CSR2150N	CH	3	<b>V1-T4-62</b>	<b>CMBE88B150BTS</b> <sup>⑤⑦</sup>	<b>CMBE88B150BTF</b> <sup>⑤⑦</sup>
150	None	UG	22	4	32/42	CSR2150N	CH	7	<b>V1-T4-61</b>	<b>CMBE3242B150BS</b> <sup>⑤⑥</sup>	—
150	None	UG	10	4	20/40	CSR2150	BR	6	<b>V1-T4-61</b>	—	<b>MBE2040B150BF</b> <sup>⑥⑨</sup>

#### Notes

- ① Not available in CR.
- ② See **Page V1-T4-61** for box details.
- ③ Interrupting rating is dependent on the main breaker that is installed.
- ④ Reference drawing EUSERC DWG-301, G1.
- ⑤ Unit has copper bus.
- ⑥ Reference drawing EUSERC DWG-301/301A.
- ⑦ Units come with feed-through lugs.
- ⑧ Units include a two-pole provision for secondary main 70 A max. Type BR, BRH, BRHH.
- ⑨ Please use RH-Type hubs on top end wall for overhead feed.

**Note:** See knockout drawings on **Pages V1-T4-61 through V1-T4-67** for hub information.

**Combination Service Entrance Devices—EUSERC, continued**

Ampere Rating	By-pass	Service	kAIC	Jaws	Distribution	Main	Branch Breaker Type	Dimensions and Enclosure Shape <sup>②</sup>	Page Numbers Knockout <sup>②</sup>	Catalog Number—Surface	Catalog Number—Flush
<b>Ring Style All-in-Ones (includes distribution section), continued</b>											
150	None	OH/UG	22	4	20/40	CSR2150	BR	—	—	MBE2040B150BTS <sup>③</sup>	—
150	None	OH/UG	10	4	4/8	CSR2150	BR	3	V1-T4-62	MBE48B150BTS	—
200	None	OH/UG	10	4	4/8	CSR2200	BR	3	V1-T4-62	MBE48B200BTS <sup>④</sup>	MBE48B200BTF <sup>④</sup>
200	None	OH/UG	22	4	8	CSR2200N	CH	3	V1-T4-62	CMBE88B200BTS <sup>④⑤</sup>	CMBE88B200BTF <sup>④⑤</sup>
200	None	OH/UG	10	4	8	CSR2200	BR	3	V1-T4-62	MBE88B200BTS	—
200	None	OH/UG	10	4	4/8	CSR2200	BR	19	V1-T4-65	MBER48B200BTS <sup>④⑥</sup>	—
200	None	OH/UG	10	4	4/8	CSR2200	BR	19	V1-T4-65	MBER48B200BTS <sup>④⑥</sup>	—
200	None	OH/UG	②	4	8/16	Provision	BR	10	V1-T4-63	MBE816P200TSCU <sup>③⑤</sup>	—
200	None	OH	②	4	8/16	Provision	BR	10	V1-T4-63	MBE816P200TS <sup>③④</sup>	—
200	None	UG	②	4	6–2 Pole	Main Lug	CH	5	V1-T4-61	CMBE1212L200BS <sup>⑥⑦</sup>	MBE1212L200BTF <sup>⑦</sup>
200	None	OH/UG	②	4	6–2 Pole	Main Lug	BR	9	V1-T4-61	MBE1212L200BTS	—
200	None	OH	10	4	20/40	CSR2200	BR	10	V1-T4-63	MBE2040B200TS <sup>③</sup>	MBE2040B200TF <sup>⑧</sup>
200	None	UG	10	4	20/40	CSR2200	BR	6	V1-T4-61	MBE2040B200BS <sup>③</sup>	MBE2040B200BF <sup>⑧</sup>
200	None	OH/UG	22	4	20/40	CSR2200	BR	—	—	MBE2040BH200BTS <sup>③</sup>	—
200	None	OH/UG	22	4	20/40	CSR2200	BR	—	—	MBE2040BH200BTF <sup>③</sup>	—
200	None	UG	22	4	30/42	CSR2200	BR	7	—	—	MBE3042B200BF
200	None	UG	22	4	32/42	CSR2200N	CH	7	V1-T4-61	CMBE3242B200BS <sup>⑥⑦</sup>	CMBE3242B200BF <sup>⑥⑦</sup>
200	None	UG	22	4	40	CSR2200	BR	12	—	MBE4040B200BSH <sup>⑥⑦</sup>	—
200	None	OH/UG	22	4	40	CSR2200	BR	12	—	MBE4040B200BTS	MBE4040B200BTF <sup>⑨</sup>
200	None	OH/UG	22	4	42	CSR2200N	CH	12	—	CMBE4242B200BTS <sup>⑤</sup>	—
200	None	OH/UG	10	4	20/40	CSR2200	BR	18	V1-T4-65	MBE2040B200BTS <sup>③</sup>	MBE2040B200BTF <sup>③</sup>
225	None	OH/UG	10	4	20/40	CSR2225	BR	18	V1-T4-65	MBE2040B225BTS <sup>③</sup>	MBE2040B225BTF <sup>③</sup>
225	None	UG	22	4	30/42	CSR2225	BR	7	—	—	MBE3042B225BF <sup>⑦</sup>
225	None	UG	22	4	32/42	CSR2225N	CH	7	V1-T4-61	CMBE3242B225BS <sup>⑥⑦</sup>	CMBE3242B225BF <sup>⑥⑦</sup>

**Notes**

- ① See **Page V1-T4-61** for box details.
- ② Interrupting rating is dependent on the main breaker that is installed.
- ③ Please use RH-Type hubs on top end wall for overhead feed.
- ④ Units come with feed-through lugs.
- ⑤ Unit has copper bus.
- ⑥ Semi-flush flange, not full stucco flange.
- ⑦ Reference drawing EUSERC DWG-301/301A.
- ⑧ When a provision for main is provided, order one of the main breakers listed on **Page V1-T4-61**. All panels are dual labeled to accept Types BW or CSR Main Breakers.
- ⑨ Includes factory-mounted 2.50-inch hub on bottom endwall. UG feed only.



West Coast All-In-One Design



### Contents

<b>Description</b>	<b>Page</b>
Residential Meter Breakers .....	<b>V1-T4-35</b>
Non-EUSERC Combination Service Entrance Devices 100–200 A Styles .....	<b>V1-T4-37</b>
EUSERC Required Service Entrance Devices 100–225 A .....	<b>V1-T4-41</b>
West Coast All-In-One Design Product Selection .....	<b>V1-T4-45</b>
Dimensions and Knockouts .....	<b>V1-T4-45</b>
House Panels .....	<b>V1-T4-48</b>
Aluminum Meter Breakers .....	<b>V1-T4-53</b>
CH Style Renovation Solutions .....	<b>V1-T4-54</b>
Commercial Safety Sockets .....	<b>V1-T4-55</b>
Meter Breakers Accessories .....	<b>V1-T4-58</b>

### West Coast All-In-One Design

#### Product Description

A metering device that may contain a meter socket, main breaker and distribution section within the same enclosure.

#### Features, Benefits and Functions

- Semi-flush mounting. 7-inch design ideal for stucco homes
- Endwall knockouts are easily accessible for future wiring without damaging stucco
- Knockout in back of case for mounting car-charging receptacle in garage (meets future electric car requirements)
- Outboard split neutral for easy wiring
- Commercial grade main breaker
- Value-added kits available: Hub adapter plate

Product Selection

MBED3042B200BF



7-Inch Deep Meter Breaker—Standard Design OH/NG ①

Ampere Rating	Bypass	Service	kAIC	Jaws	Distribution	Main	Branch Breaker Type	Catalog Number—Flush	Factory-Installed Kits
100	None	UG	10	4	18/36	CCVH2100	BR	MBED1836B100BF	—
125	None	UG	10	4	18/36	CCVH2125	BR	MBED1836B125BF	—
200	None	UG	10	4	20/40	CCVH2200	BR	MBED2040B200BF	—
200 ②	None	UG	10	4	20/40	CCVH2200	BR	MBED2040B200BFN	—
200	None	UG	10	4	30/42	CCVH2200	BR	MBED3042B200BF	—
225	None	UG	10	4	20/40	CCVH2225	BR	MBED2040B225BF	—
225 ②	None	UG	10	4	20/40	CCVH2225	BR	MBED2040B225BFN	—
225	None	UG	10	4	30/42	CCVH2225	BR	MBED3042B225BF	—

Dimensions and Knockouts

Approximate Dimensions in Inches (mm)

7-Inch Deep Meter Breaker

Catalog Number—Flush	Height	Width	Depth
MBED1836B100BF	38.00 (965.2)	14.19 (360.4)	7.00 (177.8)
MBED1836B125BF	38.00 (965.2)	14.19 (360.4)	7.00 (177.8)
MBED2040B200BF	38.00 (965.2)	14.19 (360.4)	7.00 (177.8)
MBED2040B200BFN	42.50 (1079.5)	14.19 (360.4)	7.00 (177.8)
MBED3042B200BF	42.50 (1079.5)	14.19 (360.4)	7.00 (177.8)
MBED2040B225BF	38.00 (965.2)	14.19 (360.4)	7.00 (177.8)
MBED2040B225BFN	42.50 (1079.5)	14.19 (360.4)	7.00 (177.8)
MBED3042B225BF	42.50 (1079.5)	14.19 (360.4)	7.00 (177.8)

Notes

- ① Reference drawing EUSERC DWG-301A, G1
- ② Main Breaker Bus connected to 20/40 distribution. Main and Disconnect in same compartment.

# 4.2

## Metering Products

### Meter Breakers

4

Approximate Dimensions in Inches (mm)

Catalog Numbers MBED2040B200BFN, MBED20408225BFN, MBED3042B200BF, MBED3042B225BF, MBED2040B200BF, MBED2040B225BF, MBED1836B100BF, MBED1836B125BF

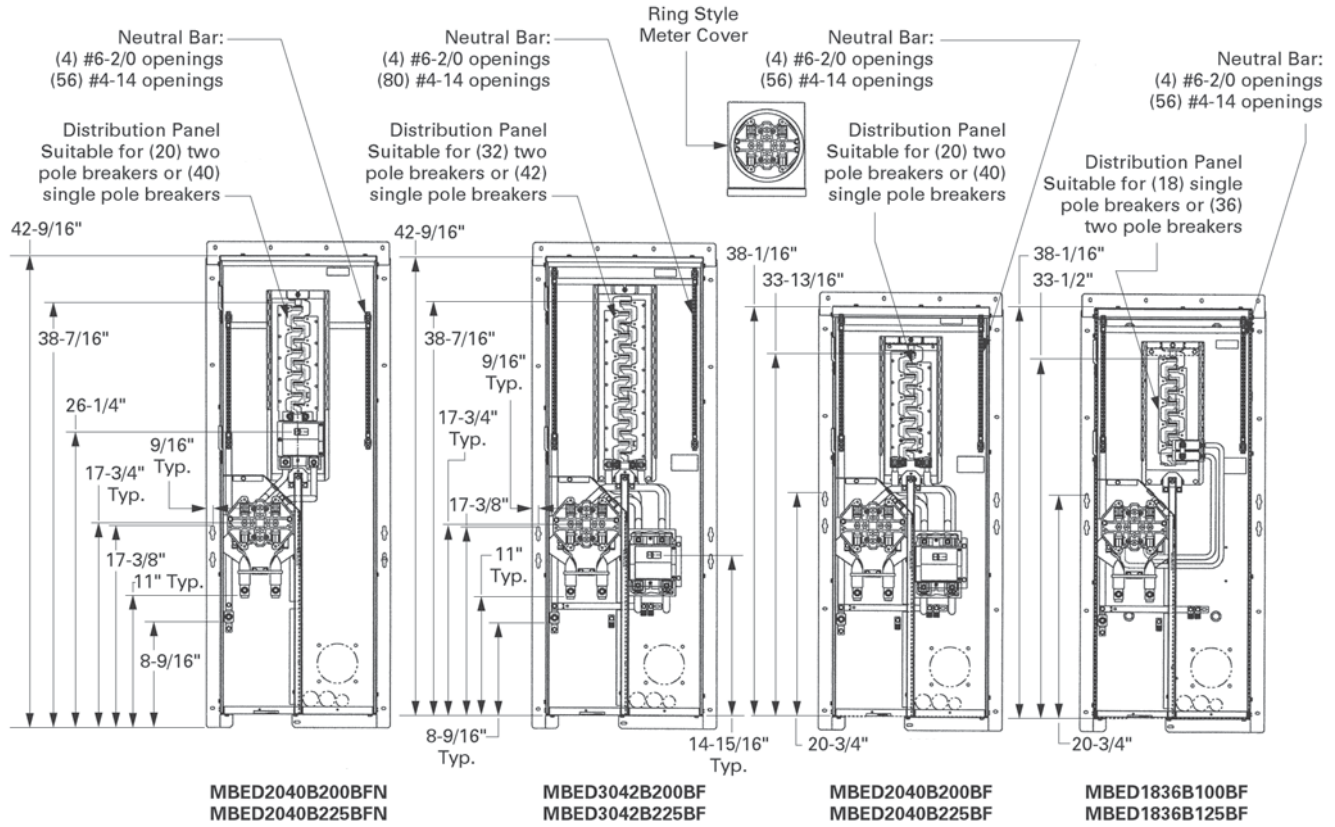

Knockout Configurations and Dimensions for MBED2040B200BFN, MBED20408225BFN, MBED3042B200BF, MBED3042B225BF, MBED2040B200BF, MBED2040B225BF, MBED1836B100BF, MBED1836B125BF

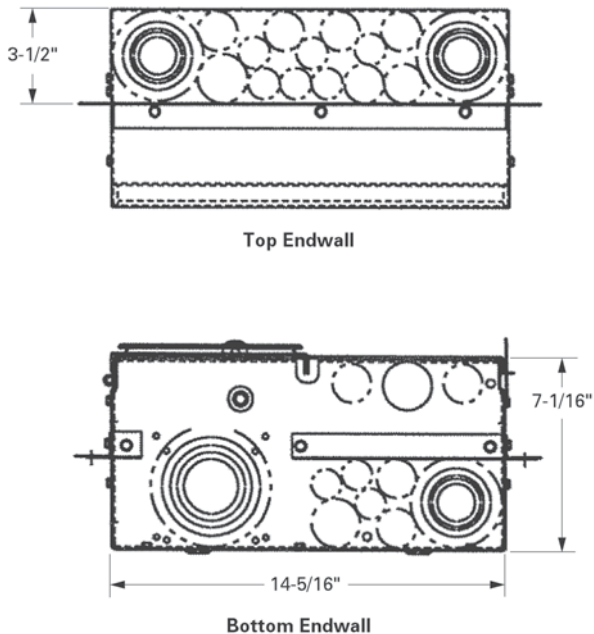

Approximate Dimensions in Inches (mm)

Catalog Numbers MBEB2003040BB, MBEB2253040BB

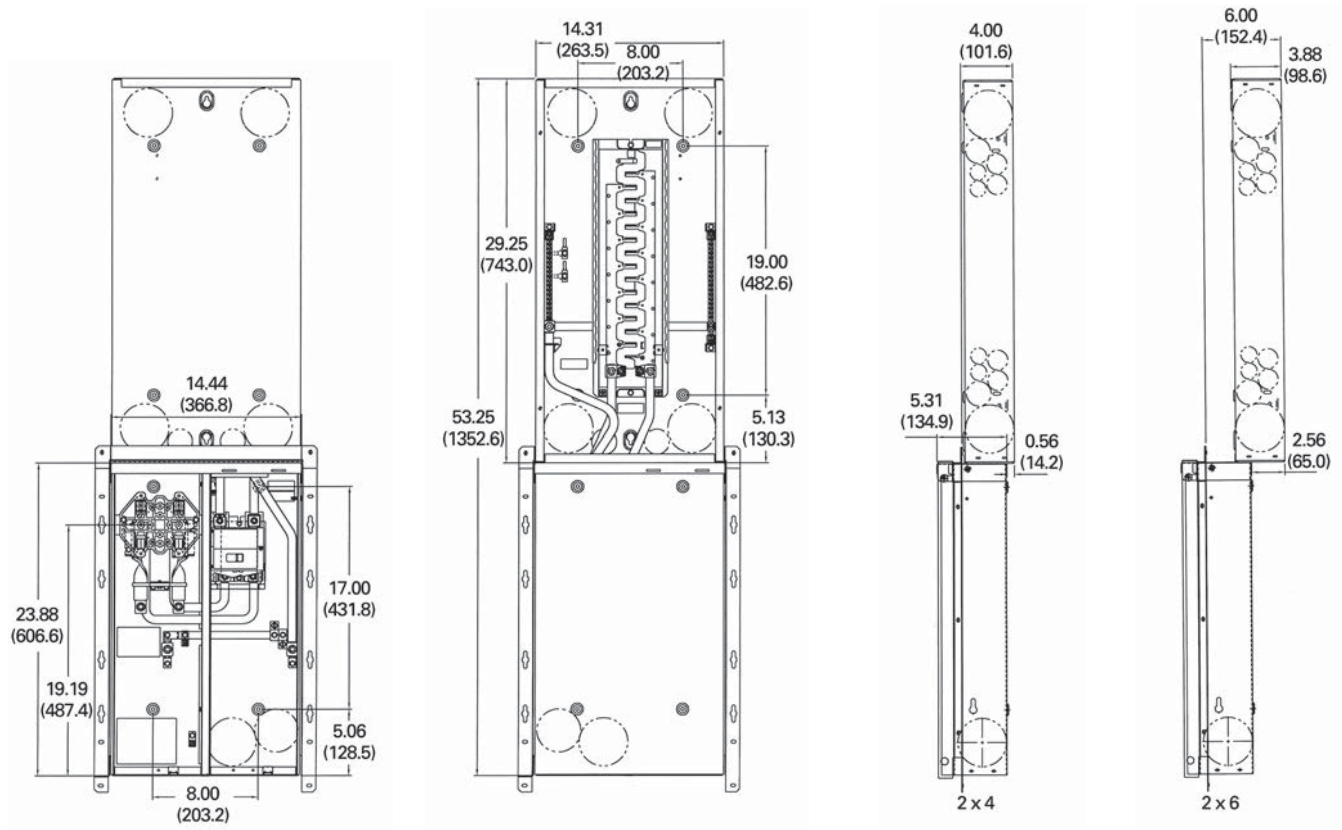

Knockout Configurations for MBEB2003040BB, MBEB2253040BB

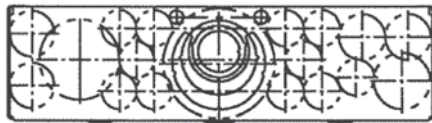

Top Endwall

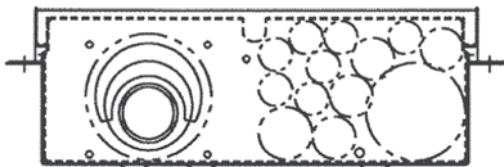

Bottom Endwall

#### House Panels



4

#### Contents

<i><b>Description</b></i>	<i><b>Page</b></i>
Residential Meter Breakers .....	<b>V1-T4-35</b>
Non-EUSERC Combination Service Entrance Devices 100–200 A Styles .....	<b>V1-T4-37</b>
EUSERC Required Service Entrance Devices 100–225 A .....	<b>V1-T4-41</b>
West Coast All-In-One Design .....	<b>V1-T4-44</b>
House Panels	
Product Selection .....	<b>V1-T4-49</b>
Accessories .....	<b>V1-T4-50</b>
Dimensions and Knockouts .....	<b>V1-T4-51</b>
Aluminum Meter Breakers .....	<b>V1-T4-53</b>
CH Style Renovation Solutions .....	<b>V1-T4-54</b>
Commercial Safety Sockets .....	<b>V1-T4-55</b>
Meter Breakers Accessories .....	<b>V1-T4-58</b>

#### House Panels

##### Product Description

Eaton’s House Panels offer a faster, easier and safer installation. These 400 A units are ideal for larger homes in North America that require meter breakers. Available in both CH and BR styles, these service entrance devices consist of a meter socket and a distribution section. In response to contractor feedback, these panels have been redesigned with a focus on flexibility, simplified wiring, and an overall ease of installation. All units come standard with a 22 kAIC main breaker. The load conductors can exit the top, bottom, side or back for greater application and installation flexibility.

##### Application Description

Additionally, Eaton’s House Panels can be used for apartments, condominiums, clubhouses or common areas.

##### Features, Benefits and Functions

- NEMA 3R rainproof
- Rated for service entrance equipment
- Lever bypass socket available on certain catalog numbers
- Pin type door hinges
- Socket to distribution section is connected via insulated cable for safety
- Second main space can accept 100–200 A BW, CSR or CSR breakers

##### Standards and Certifications

- Ring style units meet EUSERC requirements
- UL listed



Product Selection

House Panels

400 A "House Panels"



Ampere Rating	Security ①	Bypass ②	Main Breaker	Optional Secondary Main Breaker (Not Included)	Service Type	kAIC	Dist.	Line Side Main Lugs and Neutral (Lugs Not Included)	Semi-Flush Catalog Number ③④	Surface Catalog Number ④
300	Ringless	Lever	CSR2150	BW/CSR	OH/UG	22	8/16	Lug landings for compression	—	HP816P300BSL
300	Ringless	Lever	CSR2150	BW/CSR	UG	22	None		—	HPC30SHL
400	Ring	None	CSR2200N	CSH	UG	22	32/42	Lug landings for compression	—	CG403242SH ⑥
400	Ring	None	CSR2200N	CSH	UG	22	12/12		—	CG1212P400BS ⑥⑦
400	Ring	Manual / TEST ⑤	CSR2200	BRH/CSR	UG	22	None	Lug landings for compression	—	HP40SHA ⑧
400	Ring	Manual / TEST ⑤	CSR2200	BRH/CSR	UG	22	40/40		—	HP404040SHA ⑧⑨
400	Ring	None	DK2400	None	UG	22	None	Lug landings for compression	—	HP40 ⑤
400	Ring	None	CSR2200	BRH/CSR	UG	22	None		—	HP40SH ⑥⑧
400	Ring	None	DK2400	None	UG	22	24/42	Lug landings for compression	—	HP402442 ⑥
400	Ring	None	CSR220	BRH/CSR	UG	22	40/40		—	HP404040SHF ⑥ HP404040SH ⑥⑧
400	Ring	Manual / TEST ⑤	CSR2200	BRH/CSR	UG	22	40/40	Lug landings for compression	—	HP404040SHFA ⑥ —
400	Ring	None	CSR2200	BRH/CSR	UG	22	8/16		—	HP816P400BS ⑥⑦⑩
400	Ringless	Lever	CSR2200N	CSH	UG	22	12/12	Lug landings for compression	—	CG1212P400BSL ⑦
400	Ringless	Lever	CSR2200N	CSH	UG	22	42/42		—	CG404242SHL
400	Ringless	Lever	CSR2200	BRH/CSR	UG	22	None	Lug landings for compression	—	HP40SHL ⑧
400	Ringless	Lever	CSR2200	BRH/CSR	OH/UG	22	None		—	HPC40SHL ⑧
400	Ringless	Lever	CSR2200	BRH/CSR	UG	22	40/40	Lug landings for compression	—	HP404040SHL ⑧
400	Ringless	Lever	CSR2200	BRH/CSR	UG	22	8/16		—	HP816P400BSL ⑦⑧⑩
400	Ringless	Lever	CSR2200	BRH/CSR	OH/UG	22	4/6	Lug landings for compression	—	HPC4046SHLG ⑪
400	Ringless	Lever	CSR2200	BRH/CSR	OH/UG	22	4/6		—	HPC4046SHLX ⑫
<b>Bolt-On Socket</b>										
400	Ringless	None	DK2400	None	UG	22	24/40	Lug landings for compression	—	HP402440B ⑬
400	Ringless	None	CSR2200	BRH/CSR	UG	22	24/40		—	HP402440SBH ⑬⑭





Notes

- ① Confirm security type for individual EUSERC utility requirements.
- ② Included in all of the following devices.
- ③ If unit needs to be semi-flush, order accessory item catalog number **HPPR** to convert **all** surface mounting devices to semi-flush mounting.
- ④ BR style has **HP** prefix. CH style has **CG** prefix.
- ⑤ "Test" or "Manual" bypass allows utility capability to bypass the meter socket during service operations. The terms are specific to meeting utility requirements but function identically.
- ⑥ Reference drawing EUSERC DWG-302A, G1.
- ⑦ Feed-through lugs included.
- ⑧ For 10 kAIC, use BR or BW breakers as secondary main.
- ⑨ Includes manual bypass and additional ground lug to meet Nevada Power requirements.
- ⑩ To order a 5th Jaw Kit, please order MSL5TK.
- ⑪ Georgia Power approved.
- ⑫ Xcel approved.
- ⑬ Bolt-on meter socket.

#### Accessories

- Top-feed gutter kit to ease top-fed installation
- Re-engineered, adjustable flush mount kit for a cleaner installation
- 100 A second main breaker kit
- New 750 kcmil box type lug kit

#### Accessories

	Description	Catalog Number
	Top feed kit to convert surface mount house panel for overhead service	HP40TFKIT
	750 kcmil lug kit	HPBLK750
	Manual bypass kit	HPBPK
	Flushmount kit	HPPR
	100 A 2nd main kit (Type BR branch)	HP2NDMNKIT
	100 A 2nd main kit (Type CH branch)	CH2NDMNKIT
	5th jaw for lever bypass house panels	ARP00326CH
	Locates 3-inch (only) incoming conduit to back of can by utilizing the 4-inch knockout useful in semi-flush applications	HP40HUBPLATE

**Dimensions and Knockouts**

Approximate Dimensions in Inches (mm)

Catalog Numbers HPC40SHL and HPC30SHL

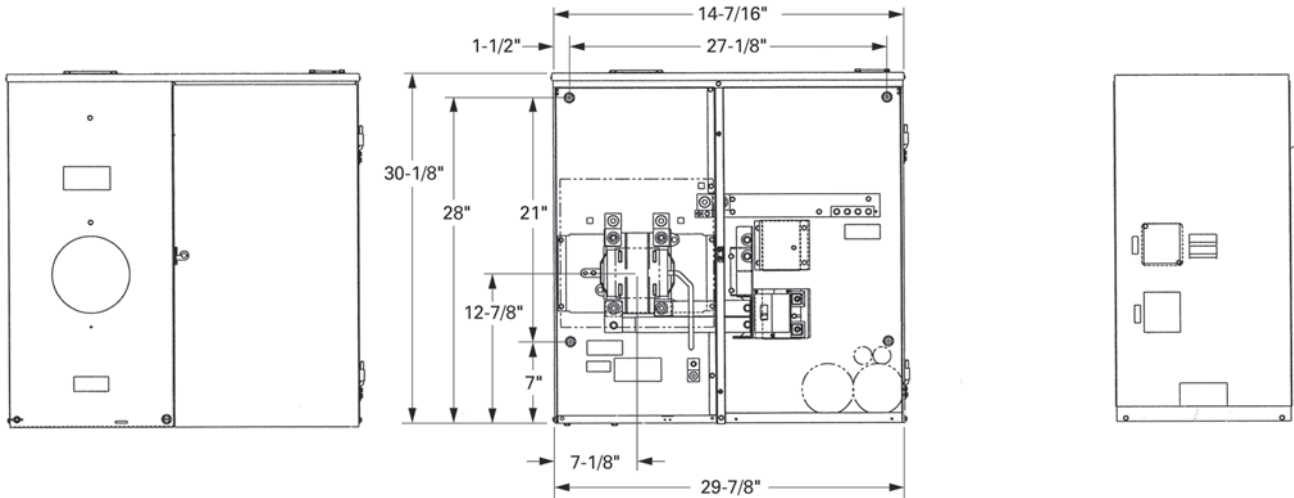

**Knockout Configurations and Dimensions for HPC40SHL and HPC30SHL**

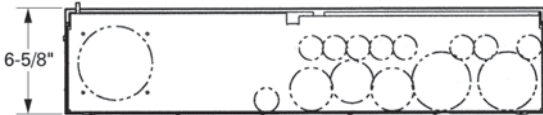



# 4.2

## Metering Products

### Meter Breakers

Approximate Dimensions in Inches (mm)

#### House Panel Dimensions and Knockouts—For All House Panels Except Those With HPCPREFIX

4

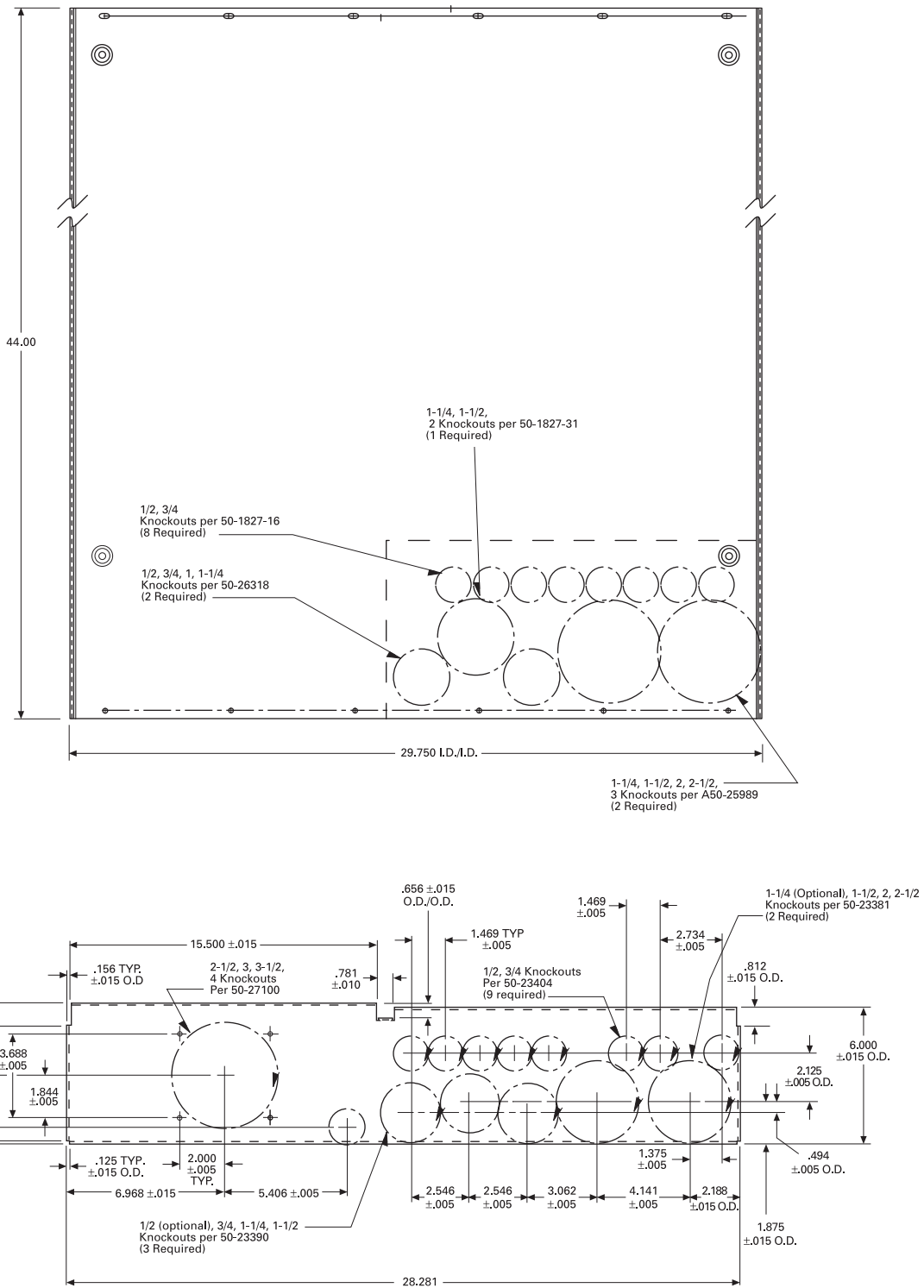

Aluminum Meter Breakers

Contents

<i>Description</i>	<i>Page</i>
Residential Meter Breakers . . . . .	<b>V1-T4-35</b>
Non-EUSERC Combination Service Entrance Devices 100–200 A Styles . . . . .	<b>V1-T4-37</b>
EUSERC Required Service Entrance Devices 100–225 A . . . . .	<b>V1-T4-41</b>
West Coast All-In-One Design . . . . .	<b>V1-T4-44</b>
House Panels . . . . .	<b>V1-T4-48</b>
Aluminum Meter Breakers	
CH Style Renovation Solutions . . . . .	<b>V1-T4-54</b>
Commercial Safety Sockets . . . . .	<b>V1-T4-55</b>
Meter Breakers Accessories . . . . .	<b>V1-T4-58</b>

Aluminum Meter Breakers

Product Description

Eaton’s Aluminum Meter Breaker enclosure and external cover offers excellent corrosion resistance in the harshest coastal environments. The meter breaker’s light weight and overhead/underground design offers flexibility and ease of installation.

Features and Benefits

- Overhead/underground design provides flexibility with wiring options
- Steel meter guides are standard, which provides a means of easy installation of the utility glass bulb meter into the meter’s jaws
- Main Lug Only design includes six two-pole breaker locations, which complies with National Electrical Code 225.33 (maximum number of disconnects)
- Distribution section accepts BR branch breakers
- Single-phase, three-wire 120/240 Vac applications
- Hub closure plate is provided, attached to the top of the device
- Optional fifth jaw can be applied to 3 o’clock or 9 o’clock meter socket position
- 10-year warranty
- For customer support, contact Eaton’s Technical Resource Center at 1-877-ETN-CARE
- For additional information or to place an order, contact your local Eaton representative or visit us at [www.eaton.com](http://www.eaton.com)

Catalog Number Selection

Aluminum Meter Breakers

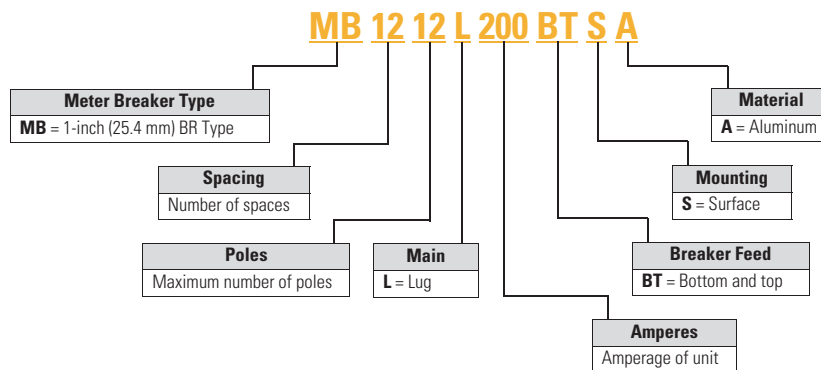

**CH Style Renovation Solutions**



**Contents**

<i>Description</i>	<i>Page</i>
Residential Meter Breakers . . . . .	<b>V1-T4-35</b>
Non-EUSERC Combination Service Entrance Devices 100–200 A Styles . . . . .	<b>V1-T4-37</b>
EUSERC Required Service Entrance Devices 100–225 A . . . . .	<b>V1-T4-41</b>
West Coast All-In-One Design . . . . .	<b>V1-T4-44</b>
House Panels . . . . .	<b>V1-T4-48</b>
Aluminum Meter Breakers . . . . .	<b>V1-T4-53</b>
CH Style Renovation Solutions Commercial Safety Sockets . . . . .	<b>V1-T4-55</b>
Meter Breakers Accessories . . . . .	<b>V1-T4-58</b>

**CH Style Renovation Solutions**

**Product Description**

- Ring style meter socket design
- Provisional main breaker or factory main breaker available
- Center top feed design
- Exit bottom or top design
- 100 A, 125 A or 200 A ratings available

**Product Selection**

**CH Style Retrofit Solutions** ①

Ampere Rating	Description	Catalog Number
100	CH, 22 circuit, provision, center top feed, exit top or bottom, flush, OH/UG	<b>CMBE22P100BTFR</b>
125	CH, 22 circuit, provision, center top feed, exit top or bottom, surface, OH/UG	<b>CMBE22P125BTSR</b>
125	CH, 22 circuit, provision, center top feed, exit top or bottom, flush, OH/UG	<b>CMBE22P125BTFR</b>
200	CH, 32/42 circuit, 200 A main breaker, center top feed, exit top or bottom, semi-flush, OH/UG	<b>CMBE3242B200BTS</b>
200	CH, 32/42 circuit, 200 A main breaker, center top feed, exit top or bottom, flush, OH/UG	<b>CMBE3242B200BTFR</b>

**Note**

① Reference drawing EUSERC DWG-308, G1.

**Commercial Safety Sockets**



**Contents**

<i>Description</i>	<i>Page</i>
Residential Meter Breakers . . . . .	<b>V1-T4-35</b>
Non-EUSERC Combination Service Entrance Devices 100–200 A Styles . . . . .	<b>V1-T4-37</b>
EUSERC Required Service Entrance Devices 100–225 A . . . . .	<b>V1-T4-41</b>
West Coast All-In-One Design . . . . .	<b>V1-T4-44</b>
House Panels . . . . .	<b>V1-T4-48</b>
Aluminum Meter Breakers . . . . .	<b>V1-T4-53</b>
CH Style Renovation Solutions . . . . .	<b>V1-T4-54</b>
Commercial Safety Sockets Product Selection . . . . .	<b>V1-T4-56</b>
Meter Breakers Accessories . . . . .	<b>V1-T4-58</b>

**Commercial Safety Sockets**

**Product Description**

A Commercial Safety Socket is service entrance equipment that consists of a commercial meter socket with a test block, and may come with or without a loadcenter type distribution section.

**Application Description**

Eaton's Commercial Safety Sockets are typically used where a single meter socket or single meter socket with a distribution section are needed. These areas could include a commercial business, commercial office building, individual retail facilities and signs and street lighting. Commercial Safety Sockets are typically used in EUSERC utility regions.

**Features, Benefits and Functions**

**Commercial Safety Sockets with No Secondary Feeder**



- Ring type continuous duty meter socket. 600 Vac maximum, single- or three-phase
- 100 and 200 A units
- Bussed connection from meter socket to test block
- For use with self-contained watt-hour meter
- Conform with EUSERC standards
- NEMA 3R construction for indoor/outdoor applications
- Units can be individually mounted with provisions for hub kits and pole mounting

**Overhead Combination Units**



- NEMA 3R construction for indoor/outdoor applications
- T-fuse protection, 480 Vac maximum
- Line at top, load at bottom
- 100 and 200 A units available up to 480 Vac maximum
- Circuit breaker protection to 480 Vac maximum in 10, 22, 42 and 100 kAIC ratings
- Factory-cabled connection from test block to line side of tenant main

**Underground Combination Units**



- 100 and 200 A units
- 480 Vac maximum
- NEMA 3R construction for indoor/outdoor applications
- Underground or overhead feed
- Provisions for self-contained watt-hour meter
- Bussed connection from meter socket to test block
- Tenant main disconnects are available with circuit breakers up to 480 Vac maximum and T-fuse mains, 240 Vac maximum
- Load wires can exit top or bottom

## Product Selection

## Overhead and Underground Combination Units and Individual Units

CH127TB



4

Individual Safety Sockets—600 V Maximum—No Secondary Feeder Devices <sup>①</sup>

Ampere Rating	No. of Jaws	AC Voltage	Service	Phase, Wire	Maximum Interrupting Rating	Wire Size	Catalog Number
125	4	600	OH/UG	Single-phase, three-wire	②	#14–2/0	CH114TB
125	5	600	OH/UG	Three-phase, three-wire	②	#14–2/0	CH115TB
125	7	600	OH/UG	Three-phase, four-wire	②	#14–2/0	CH117TB
200	4	600	OH/UG	Single-phase, three-wire	②	#6–250 kcmil	CH124TB
200	5	600	OH/UG	Three-phase, three-wire	②	#6–250 kcmil	CH125TB
200	7	600	OH/UG	Three-phase, four-wire	②	#6–250 kcmil	CH127TB

Commercial Safety Sockets with Provision for Main Circuit Breaker <sup>③</sup>

Ampere Rating	No. of Jaws	AC Voltage	Service	Phase, Wire	Feeder Circuit Breaker	Maximum Interrupting Rating	Wire Size	Catalog Number
125	4	240	OH	Single-phase, three-wire	Provision <sup>④</sup>	⑥	#14–2/0	CH214MTBLB
125	7	208/120	OH	Three-phase, four-wire	Provision <sup>④</sup>	⑥	#14–2/0	CH217MTBLB
125	4	240	UG	Single-phase, three-wire	Provision <sup>④</sup>	⑥	#14–2/0	CHU214MTBLB
125	7	208/120	UG	Three-phase, four-wire	Provision <sup>④</sup>	⑥	#14–2/0	CHU217MTBLB
200	4	120/240	OH	Single-phase, three-wire	Provision <sup>⑤</sup>	⑦	#6–250 kcmil	CH224MTBLB
200	7	208/120	OH	Three-phase, four-wire	Provision <sup>⑤</sup>	⑦	#6–250 kcmil	CH227MTBLB
200	4	120/240	UG	Single-phase, three-wire	Provision <sup>⑤</sup>	⑦	#6–250 kcmil	CHU224MTBLB
200	7	208/120	UG	Three-phase, four-wire	Provision <sup>⑤</sup>	⑦	#6–250 kcmil	CHU227MTBLB

Commercial Safety Sockets with Main Circuit Breaker Included <sup>③</sup>

Ampere Rating	No. of Jaws	AC Voltage	Service	Phase, Wire	Feeder Circuit Breaker	Maximum Interrupting Rating	Wire Size	Catalog Number
100	7	480/277	OH	Three-phase, four-wire	EHD3100	14 kA	#14–2/0	CH217MTBM515
100	7	480/277	UG	Three-phase, four-wire	EHD3100	14 kA	#14–2/0	CHU217MTBMS15
200	7	480/277	OH	Three-phase, four-wire	JD3200	25 kA	#6–250 kcmil	CH227MTBHMS15
200	7	480/277	UG	Three-phase, four-wire	JD3200	25 kA	#6–250 kcmil	CHU227MTBHMS15

## Notes

- ① Reference drawing EUSERC DWG-305, G1.
- ② If being protected by a fuse, the interrupting rating of the unit is limited to the fuse AIC rating. If being protected by a single- or three-phase, 600 V breaker, the AIC is 14 kA; by a maximum 400 A, single-phase, 240 V breaker, the AIC is 18 kA; by a maximum 200 A, single- or three-phase, 240 V breaker, the AIC is 18 kA; by a maximum 125 A, single-phase, 240 V breaker, the AIC is 22 kA.
- ③ Reference drawing EUSERC DWG-305A, G1.
- ④ Order plug-on Type BR, BRH or BRHH circuit breaker separately.
- ⑤ Order Type CC breaker or CCH breaker separately.
- ⑥ Type BR = 10 kA; Type BRH = 22 kA; Type BRHH = 42 kA.
- ⑦ Type CCV = 10 kA; Type CCVH = 25 kA.

**Underground Combination Units and Safety Sockets**

CHU227MTBP

**Commercial Safety Sockets with T-Fuse Switch** ①



Ampere Rating	No. of Jaws	AC Voltage	Service	Phase, Wire	Feeder Circuit Breaker	Maximum Interrupting Rating	Wire Size
100	4	120/240	OH	Single-phase, three-wire	200 kA	#14-2/0	CH214MTBP
100	7	208/120	OH	Three-phase, four-wire	200 kA	#14-2/0	CH217MTBP
100	4	120/240	UG	Single-phase, three-wire	200 kA	#14-2/0	CHU214MTBP
100	7	208/120	UG	Three-phase, four-wire	200 kA	#14-2/0	CHU217MTBP
200	4	120/240	OH	Single-phase, three-wire	200 kA	#6-250 kcmil	CH224MTBP
200	7	208/120	OH	Three-phase, four-wire	200 kA	#6-250 kcmil	CH227MTBP
200	4	120/240	UG	Single-phase, three-wire	200 kA	#6-250 kcmil	CHU224MTBP
200	7	208/120	UG	Three-phase, four-wire	200 kA	#6-250 kcmil	CHU227MTBP

**Notes**

① Reference drawing EUSERC DWG-305A, G1.

Order Type CC or CHH breaker separately.

#### Meter Breakers Accessories



Meter Breaker with Interlock Cover

#### Meter Breakers Accessories

##### Underground Combination Units and Safety Socket Accessories

###### Hubs

Description	Carton Weight Lbs (kg)	Catalog Number
Hub closure plate	3 (1.4)	ARP00002CHB
1.00-inch (25.4 mm) hub	3 (1.4)	ARP00003CH1
1.25-inch (31.8 mm) hub	3 (1.4)	ARP00004CH12
1.50-inch (38.1 mm) hub	3 (1.4)	ARP00005CH15
2.00-inch (50.8 mm) hub	3 (1.4)	ARP00006CH2
2.50-inch (63.5 mm) hub	3 (1.4)	ARP00007CH25

###### Hub Adapter Plate

Description	Catalog Number
Hub adapter plate	MBEDADPT

###### Top Endwall (Surface) Hub Provision Selection Chart

Description	Catalog Number
1.00 (25.4)	DS100H2
1.25 (31.8)	DS125H2
1.50 (38.1)	DS150H2
2.00 (50.8)	DS200H2
2.50 (63.5)	DS250H2
3.00 (76.2)	DS300H2
Adapter Plate if using DS ___ H1 hubs only) ③	DS900AP

#### Contents

Description	Page
Residential Meter Breakers . . . . .	V1-T4-35
Non-EUSERC Combination Service Entrance Devices 100–200 A Styles . . . . .	V1-T4-37
EUSERC Required Service Entrance Devices 100–225 A . . . . .	V1-T4-41
West Coast All-In-One Design . . . . .	V1-T4-44
House Panels . . . . .	V1-T4-48
Aluminum Meter Breakers . . . . .	V1-T4-53
CH Style Renovation Solutions . . . . .	V1-T4-54
Commercial Safety Sockets . . . . .	V1-T4-55
Meter Breakers Accessories	
Mechanical Interlock Cover . . . . .	V1-T4-59
Technical Data and Specifications . . . . .	V1-T4-60
Dimensions and Knockouts . . . . .	V1-T4-61

#### Other Accessories for Meter Breakers

##### Meter Breaker Parts ①

Description	Catalog Number
<b>5th Jaw Kits</b>	
Compact and standard styles (MB and CMB)	MB5JAWKIT
EUSERC style	IMM5JKOP ②
<b>Horn Bypass Kits</b>	
Ringless Style units only (MB and CMB)	MBHBPKIT

##### Jaws

Description	Part Number
5th jaw kit	CH50371

##### Notes

- ① For breakers under 70 A used in backfed applications, add “B” to the end of the catalog string to get the appropriate “hold-down” version.
  - ② Reference drawing EUSERC DWG-G1.
  - ③ Use when DS H1 Type 1, 1.25 and 1.50-inch hubs are needed.
- Use DS...H2 hubs for bottom endwalls (for all units). Use RH hubs for top endwalls on semi-flush units. Use DS...H2 hubs for top endwalls on surface devices.

**Mechanical Interlock Cover**

Covers mechanically interlock two breakers. Covers interlock main breaker with two-pole breaker mounted in the distribution section of the meter breakers.

**Meter Breaker with Interlock Cover**



**Mechanical Interlock Cover**

Mechanical Interlock Deadfront	Meter Breaker Catalog Number
MBDF1M	CMB1212B200BTS
	CMB1212B200BTSD
	CMB1212P200BTS
	CMB1212P200BTSD
MBDF2M	MB816B200BTS
	MB816B200BTSCU
	MB816P200BTS
	MB816P200BTSCU
MBDF3M	MB816P200STD
	MB2040B200BTS
	MB2040P200BTS
MBDF4M	MB2040P200SD
	MBE816P200TS
	MBE816P200TSCU
MBDF5M	MBE2040B150BF
	MBE2040B150BS
	MBE2040B200BF
	MBE2040B200BS
MBDF6M	MBE2040B200TF
	MBE2040B200TS
	MBE2040P200TF
	MBE2040P200TS
MBDF7M	CMBE3242B150BF
	CMBE3242B150BS
	CMBE3242B200BF
	CMBE3242B200BS
	CMB3242B150BS
MBDF8M	CMB3242B200BS
	CMBE4242B200BSH
	CMBE4242B200BTF
MBDF9M	CMBE4242B200BTS
	MBE4040B200BSH
	MBE4040B200BSHH
	MBE4040B200BTF
	MBE4040B200BTS

Mechanical Interlock Deadfront	Meter Breaker Catalog Number
MBDF1AM	CMB2424B200BTS
MBDF10M	CMB24B200TFR
	CMB24B200TSR
MBDF12M	CMBX3242B200BTS
	CMBX3242P200BTS
MBDF13M	MBE3042B200BF
	MBE3042B225BF
MBDF14M	CMBE88B150BTF
	CMBE88B150BTS
	CMBE88B200BTF
	CMBE88B200BTS
MBDF15M	CMB88B150BTS
	CMB88B200BTS
	MBE48B150BTF
	MBE48B150BTS
MBDF16M	MBE48B200BTF
	MBE48B200BTS
	MBE88B150BTF
MBDF17M	MBE88B150BTS
	MBE88B200BTF
	MBE88B200BTS
	MBE2040BC200BTS
	MBE2040BH200BTF
	MBE2040BH200BTS
	MBE2040B150BTF
	MBE2040B150BTS
	MBE2040B200BTF
	MBE2040B200BTS
	MBE2040B200BTSV
	MBE2040B225BTF
	MBE2040B225BTS



## Technical Data and Specifications

### Wire Size Chart

Main	Wire Size Range Cu/Al 60 °C
	or 75 °C for Line Terminals
BR250	#14–4 kcmil
BR260	#4–1/0 kcmil
BR270	#4–1/0 kcmil
BR280	#4–1/0 kcmil
BR290	#4–1/0 kcmil
BR2100	#4–1/0 kcmil
BW2125	#2–300 kcmil
BW2150	#2–300 kcmil
BW2200	#2–300 kcmil
CSR2125	#2–300 kcmil
CSR2150	#2–300 kcmil
CSR2200	#2–300 kcmil
CSR2125N	#1/0–250 kcmil
CSR2150N	#1/0–250 kcmil
CSR2200N	#1/0–250 kcmil
125 A main lugs	—
200 A main lugs	—
MCBK225	#2–300 kcmil

### Wire Size is Determined by the Circuit Breaker Installed in the Enclosure

Wire/Application	Maximum	
	Wire Size	Ampere Rating
Aluminum—Standard	250 kcmil	200
Aluminum—Service Entrance	250 kcmil	225
Copper—Standard and Service Entrance	250 kcmil	225

#### Notes

- ① For breakers under 70 A used in backfed applications, add “B” to the end of the catalog string to get the appropriate “hold-down” version.
- ② Reference drawing EUSERC DWG-G1.
- ③ Use when DS H1 Type 1, 1.25 and 1.50-inch hubs are needed.

Use DS...H2 hubs for bottom endwalls (for all units). Use RH hubs for top endwalls on semi-flush units. Use DS...H2 hubs for top endwalls on surface devices.

**Dimensions and Knockouts**

Approximate Dimensions in Inches (mm)

**Box Styles—Five Different Styles (Shapes) of Product**

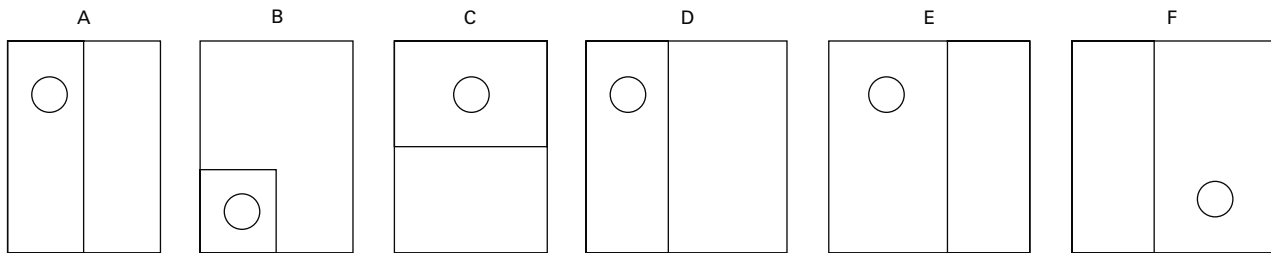

**Box Dimensions**

Box Number	Height	Width	Depth	Box Style
1	12.50 (317.5)	14.44 (366.7)	4.00 (101.6)	A
2	23.88 (606.4)	14.44 (366.7)	5.38 (136.5)	A
3	28.38 (720.7)	14.44 (366.7)	5.38 (136.5)	A
4	34.13 (866.8)	14.44 (366.7)	5.38 (136.5)	B
5	36.13 (917.6)	14.44 (366.7)	5.38 (136.5)	B
6	43.38 (1101.7)	14.44 (366.7)	5.38 (136.5)	B
7	46.88 (1190.6)	14.44 (366.7)	5.38 (136.5)	B
8	19.75 (501.7)	7.50 (190.5)	4.00 (101.6)	C
9	25.00 (635.0)	14.44 (366.7)	5.38 (136.5)	C
10	32.38 (822.3)	14.44 (366.7)	5.38 (136.5)	C
11	36.63 (930.3)	14.44 (366.7)	5.38 (136.5)	C
12	34.38 (873.1)	22.00 (558.8)	5.38 (136.5)	D
13	19.75 (501.7)	14.44 (366.7)	5.38 (136.5)	E
14	39.91 (1013.7)	14.44 (366.7)	5.38 (136.5)	C
15	23.88 (606.6)	13.00 (330.2)	4.94 (125.5)	F
16	28.38 (720.9)	13.00 (330.2)	4.94 (125.5)	F
17	34.19 (868.4)	22.13 (562.1)	5.00 (127.0)	D
18	36.06 (915.9)	16.63 (422.4)	5.50 (139.7)	A
19	28.38 (720.9)	14.44 (366.8)	4.94 (125.5)	A
20	32.06 (814.3)	14.44 (366.8)	4.94 (125.5)	C
21	25.50 (647.7)	14.44 (366.8)	4.94 (125.5)	C

# 4.2

## Metering Products

### Meter Breakers

Approximate Dimensions in Inches (mm)

**Knockouts for Stucco and Surface Units Catalog Numbers—  
CMBE3242B200BF, CMBE3242B225BF, MBE2040B200BF,  
MBE2040B150BF, MBE1428B100BF, MBE1212L200BTF,  
MBE1836B125BF and MBE1212L200BTS**

4

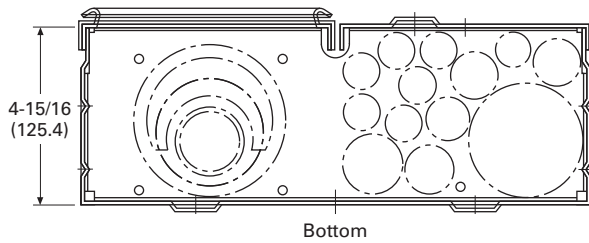
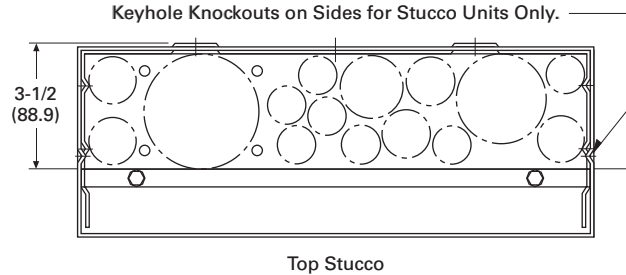

**Knockouts for Stucco and Surface Units Catalog Numbers—  
CMBE3242B150BS, CMBE3242B200BS, CMBE3242B225BS,  
CMBE1212L200BS, MBE2040B200BS, MBE1428B100BS,  
MBE1212L200BTS, CMB3242B150BS and CMB3242B200BS**

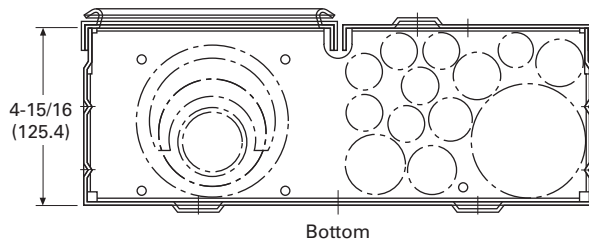
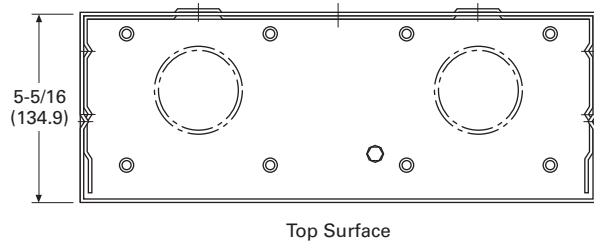

#### Top Endwall (Surface)

Hub Provision Catalog Number	Quantity
DS100H2	①
DS125H2	①
DS150H2	①
DS200H2	①
DS250H2	①
DS300H2	①
DS900AP (Adapter Plate if using DS___H1 hubs only) ②	①

#### Top Endwall (Stucco) ③

Knockout Size Dimensions in Inches (mm)	Quantity
1.25, 1.50, 2.00, 2.50 (31.8, 38.1, 50.8, 63.5)	1
1.00, 1.25, 1.50 (25.4, 31.8, 38.1)	1
0.50, 0.75, 1.00 (12.7, 19.1, 25.4)	1
0.50, 0.75 (12.7, 19.1)	3
0.50 (12.7)	3

#### Bottom Endwall

Knockout Size Dimensions in Inches (mm)	Quantity
0.50 (12.7)	7
0.50, 0.75 (12.7, 19.1)	4
0.50, 0.75, 1.00 (12.7, 19.1, 25.4)	1
1.00, 1.25, 1.50, 2.00 (25.4, 31.8, 38.1, 50.8)	1
1.25, 1.50, 2.00, 2.50, 3.00 (31.8, 38.1, 50.8, 63.5, 76.2)	1

#### Notes

- ① For details regarding quantities, please contact the Technical Resource Center (TRC) at 1-877-ETN-CARE.
- ② Use when DS H1 Type 1, 1.25 and 1.50-inch hubs are needed.
- ③ RH hubs are to be used for Top Endwall (Stucco) endwalls.

Approximate Dimensions in Inches (mm)

**Knockouts for Stucco and Surface Units Catalog Numbers—  
CMBE88B150BTF, CMBE88B200BTF, MBE24L125BTF,  
MBE24L200BTF, MBE48B200BTF, MBEB200BTF,  
MBE1224B100BTF and MBE1224B125BTF**

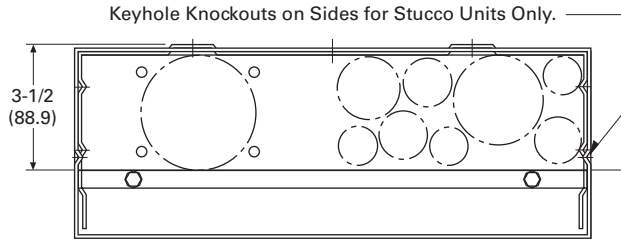

Top Stucco

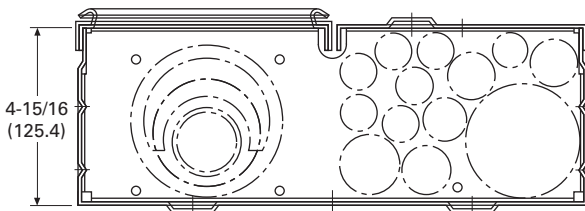

Bottom

**Knockouts for Stucco and Surface Units Catalog Numbers—  
CMBB150BTS, CMBB200BTS, CMBP200BTS,  
CMBE24L125BTS, CMB24L125BTS, CMBE24L200BTS,  
CMBEB200BTS, CMBEB150BTS, CMBE88B150BTS,  
CMBP200BTS, CMBE88B200BTS, MBE24L125BTS,  
MBE24L200BTS, MBE48B150BTS, MBE48B200BTS,  
MBE88B200BTS, MBEB200BTS, MBE1224B100BTS,  
MBE1224B125BTS, CMB88B150BTS, CMB88B200BTS  
and MB48B200BTS**

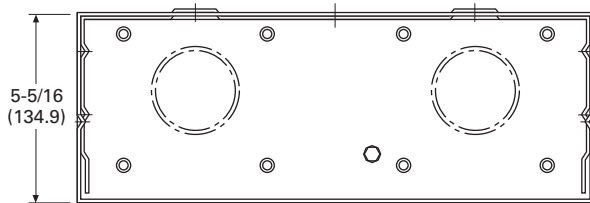

Top Surface

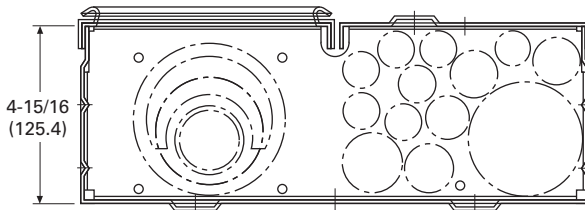

Bottom

**Top Endwall (Surface)**

Hub Provision Catalog Number	Quantity
DS100H2	①
DS125H2	①
DS150H2	①
DS200H2	①
DS250H2	①
DS300H2	①
DS900AP (Adapter Plate if using DS___H1 hubs only) ②	①

**Top Endwall (Stucco) ③**

Knockout Size Dimensions in Inches (mm)	Quantity
1.25, 1.50, 2.00, 2.50 (31.8, 38.1, 50.8, 63.5)	1
1.00, 1.25, 1.50 (25.4, 31.8, 38.1)	1
0.50, 0.75, 1.00 (12.7, 19.1, 25.4)	1
0.50, 0.75 (12.7, 19.1)	3
0.50 (12.7)	3

**Bottom Endwall**

Knockout Size Dimensions in Inches (mm)	Quantity
0.50 (12.7)	7
0.50, 0.75 (12.7, 19.1)	4
0.50, 0.75, 1.00 (12.7, 19.1, 25.4)	1
1.00, 1.25, 1.50, 2.00 (25.4, 31.8, 38.1, 50.8)	1
1.25, 1.50, 2.00, 2.50, 3.00 (31.8, 38.1, 50.8, 63.5, 76.2)	1

**Notes**

- ① For details regarding quantities, please contact the Technical Resource Center (TRC) at 1-877-ETN-CARE.
- ② Use when DS H1 Type 1, 1.25 and 1.50-inch hubs are needed.
- ③ RH hubs are to be used for Top Endwall (Stucco) endwalls.

# 4.2

## Metering Products

### Meter Breakers

4

Approximate Dimensions in Inches (mm)

#### Knockouts for Stucco and Surface Units Catalog Number—MMBE2040B200TF

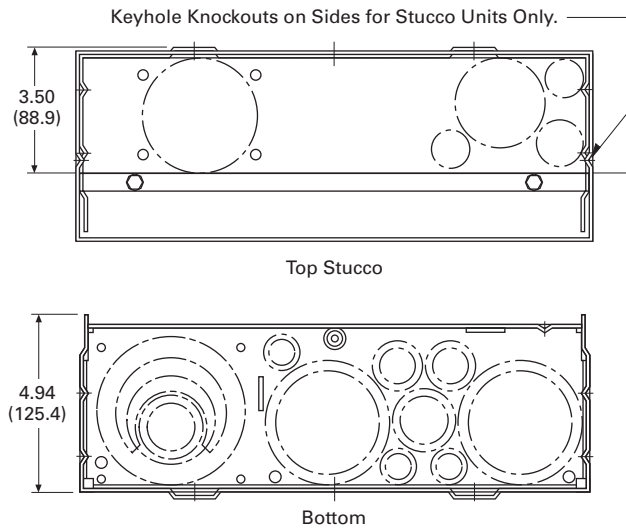

#### Knockouts for Stucco and Surface Units Catalog Numbers—MBE1224B100TS, MBE1224B125TS, MBE816P200TS, MBE816P200TSCU, MBE2040B200TS, CMB1212P200BTS, CMB1212P200BTSD, CMB1212B200BTS, MB1212L200BTS and CMB1212L200BTS

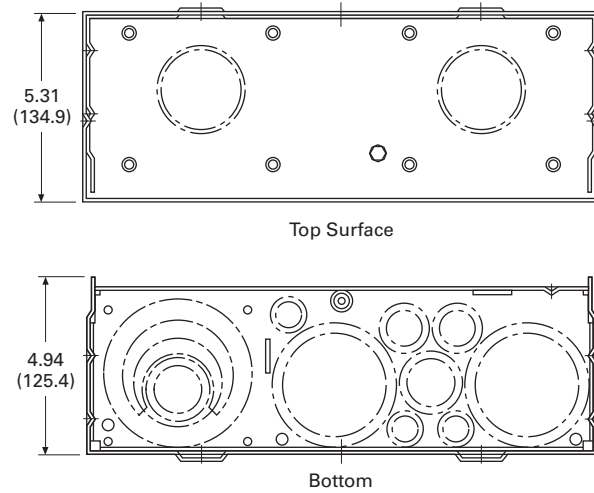

#### Top Endwall (Surface)

Hub Provision Catalog Number	Quantity
DS100H2	①
DS125H2	①
DS150H2	①
DS200H2	①
DS250H2	①
DS300H2	①
DS900AP (Adapter Plate) ②	①

#### Top Endwall (Stucco) ③

Knockout Size Dimensions in Inches (mm)	Quantity
1.25, 1.50, 2.00, 2.50 (31.8, 38.1, 50.8, 63.5)	1
1.00, 1.25, 1.50 (25.4, 31.8, 38.1)	1
0.50, 0.75, 1.00 (12.7, 19.1, 25.4)	1
0.50, 0.75 (12.7, 19.1)	3
0.50 (12.7)	3

#### Bottom Endwall

Knockout Size Dimensions in Inches (mm)	Quantity
0.50 (12.7)	7
0.50, 0.75 (12.7, 19.1)	4
0.50, 0.75, 1.00 (12.7, 19.1, 25.4)	1
1.00, 1.25, 1.50, 2.00 (25.4, 31.8, 38.1, 50.8)	1
1.25, 1.50, 2.00, 2.50, 3.00 (31.8, 38.1, 50.8, 63.5, 76.2)	1

#### Notes

- ① For details regarding quantities, please contact the Technical Resource Center (TRC) at 1-877-ETN-CARE.
- ② Use when DS H1 Type 1, 1.25 and 1.50-inch hubs are needed.
- ③ RH hubs are to be used for Top Endwall (Stucco) endwalls.

Approximate Dimensions in Inches (mm)

**Knockouts for Stucco and Surface Units**

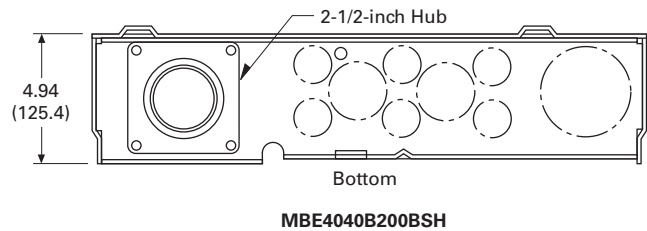
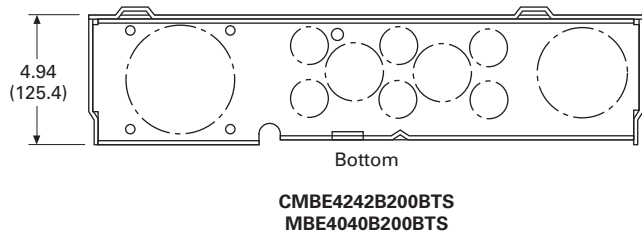
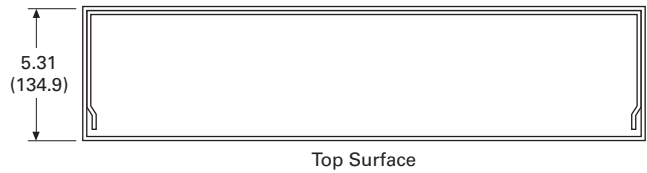
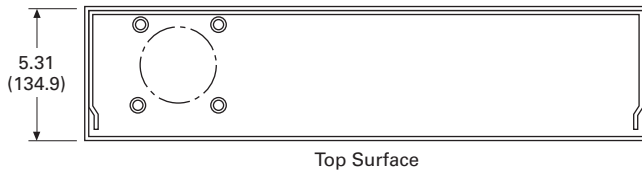
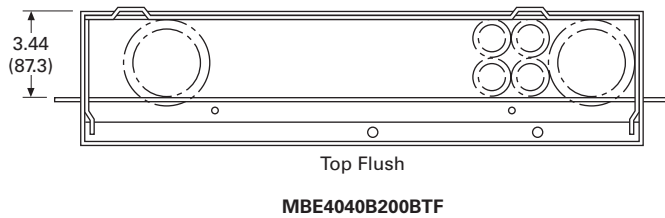

**Top Endwall (Surface)**

Hub Provision Catalog Number	Quantity
<b>DS100H2</b>	①
<b>DS125H2</b>	①
<b>DS150H2</b>	①
<b>DS200H2</b>	①
<b>DS250H2</b>	①
<b>DS300H2</b>	①
<b>DS900AP</b> (Adapter Plate) ②	①

**Top Endwall (Stucco) ③**

Knockout Size Dimensions in Inches (mm)	Quantity
1.25, 1.50, 2.00, 2.50 (31.8, 38.1, 50.8, 63.5)	2
0.50, 0.75 (12.7, 19.1)	3

**Bottom Endwall**

Knockout Size Dimensions in Inches (mm)	Quantity
0.50, 0.75 (12.7, 19.1)	6
0.50, 0.75, 1, 1.25 (12.7, 19.1, 25.4, 31.8)	2
1.00, 1.25, 1.50, 2.00, 2.50 (25.4, 31.8, 38.1, 50.8, 63.5)	1
1.00, 1.25, 1.50, 2.00, 2.50, 3.00 (25.4, 31.8, 38.1, 50.8, 63.5, 76.2)	1

**Notes**

- ① For details regarding quantities, please contact the Technical Resource Center (TRC) at 1-877-ETN-CARE.
- ② Use when DS H1 Type 1, 1.25 and 1.50-inch hubs are needed.
- ③ RH hubs are to be used for Top Endwall (Stucco) endwalls.

# 4.2

## Metering Products

### Meter Breakers

4

Approximate Dimensions in Inches (mm)

#### Knockout Configurations and Dimensions for Catalog Numbers MBER48B200BTS and CMBER88B200BTS

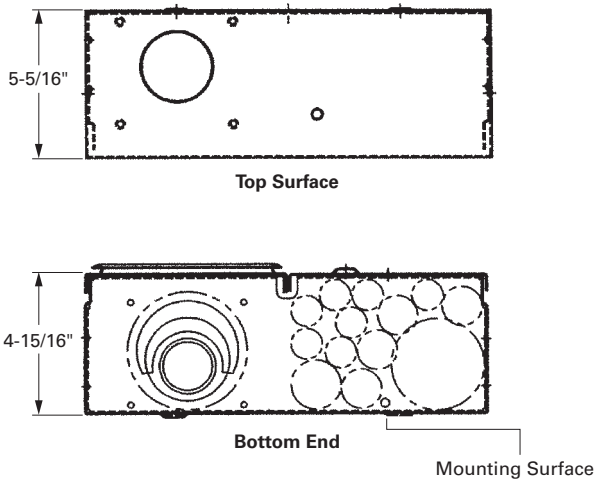

#### Semi-Flush Stucco Unit Knockout Configurations and Dimensions for MBE2040B200BTS, MBE2040B225BTS, MBE2040B200BTF and MBE2040B225BTF

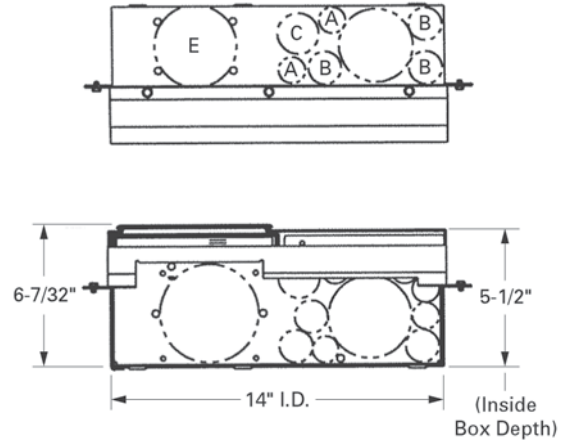

#### Knockout Configurations and Dimensions for Catalog Numbers CMBXP200BTS, CMBXB200BTS, CMBX1212P200BTS and CMBX3242P200BTS, CMBX3242B200BTS, CMBX1212B200BTS

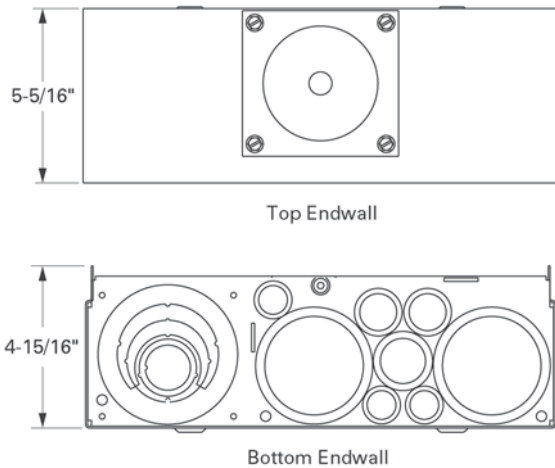

#### Knockout Configurations and Dimensions for Catalog Numbers MBT48B125BTS, MBT48B150BTS, MBT48B200BTS and MBT48P200BTS

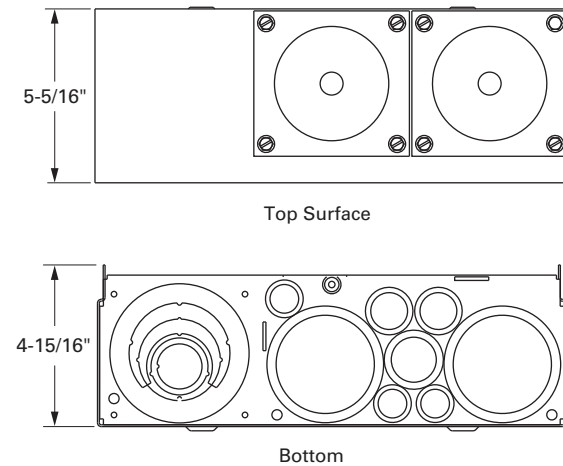

#### Surface Unit Knockout Configurations and Dimensions for MBE2040B200BTS, MBE2040B225BTS, MBE2040B200BTF and MBE2040B225BTF

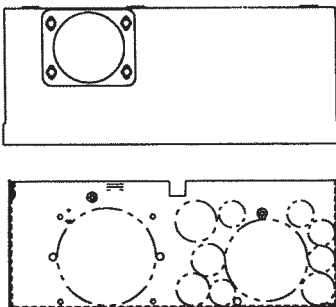

Approximate Dimensions in Inches (mm)

**Knockouts for Non-EUSERC Units Catalog Numbers—**  
**MBB150BTS, MBB200BTS, MBP200BTS, MB816P200BTS,**  
**MB816P200BTSCU, MB816P200BTSD, MB816B200BTS,**  
**MB816B200BTSCU, MB2040P200BTS, MB2040B200BTS,**  
**MBP200BTSD, MBP200SD, MB816P200STD,**  
**MB2040B150SD, MB2040B200SD and MB2040P200SD**

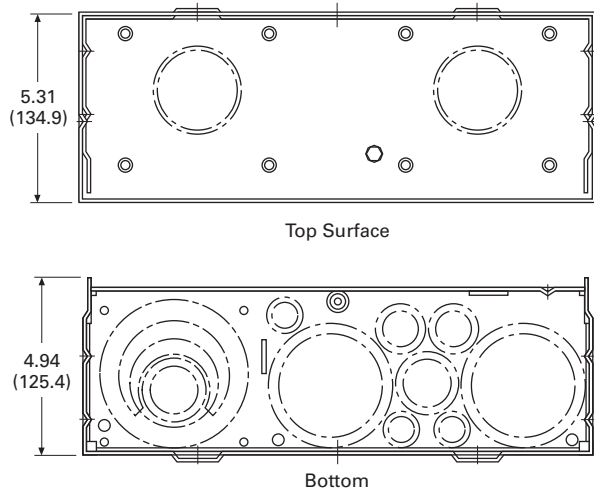

**Knockouts for Non-EUSERC Units Catalog Numbers—**  
**CMB2424B200BTS, MBB150BTSCR, MBB200BTSCR,**  
**MBB150BTSC, MBB200BTSC and CMB2436B200BTS**

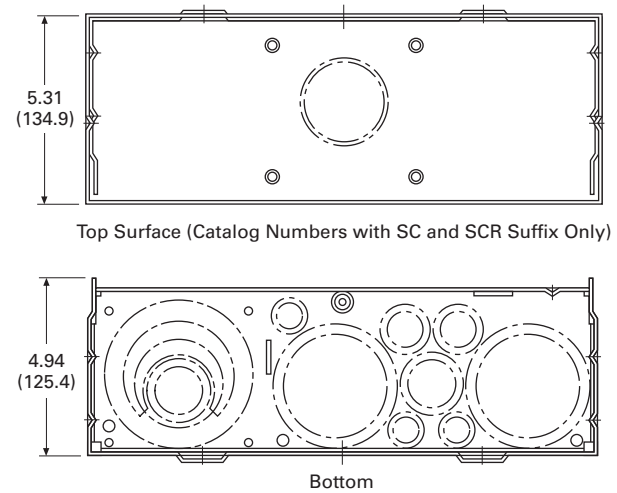

**Top Endwall (Surface)**

Hub Provision Catalog Number	Quantity
DS100H2	①
DS125H2	①
DS150H2	①
DS200H2	①
DS250H2	①
DS300H2	①
DS900AP (Adapter Plate) ②	①

**Bottom Endwall**

Knockout Size Dimensions in Inches (mm)	Quantity
0.31 (7.9)	3
0.50 (12.7)	3
0.50, 0.75 (12.7, 19.1)	2
0.75, 1.00 (12.7, 25.4)	1
1.25, 1.50, 2.00, 2.50 (19.1, 38.1, 50.8, 63.5)	2
1.50, 2.00, 2.50, 3.00 (38.1, 50.8, 63.5, 76.2)	1

**Knockouts for Non-EUSERC Units Catalog Number—**  
**CHMMB100BTS**

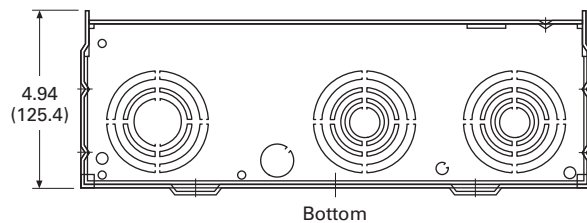

**Knockouts for Non-EUSERC Units Catalog Numbers—**  
**CHMMB150BTS and CHMMB200BTS**

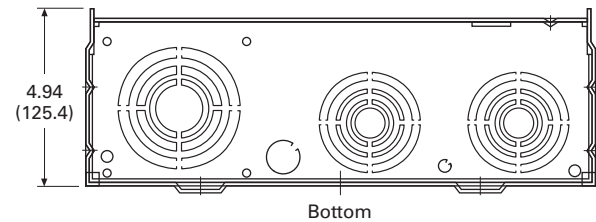

**Bottom Endwall**

Knockout Size Dimensions in Inches (mm)	Quantity
0.31 (7.9)	1
0.50 (12.7)	1
0.50, 0.75, 1.00, 1.25, 1.50, 2.00, 2.50 (12.7, 19.1, 25.4, 31.8, 38.1, 50.8, 63.5)	2
1.00, 1.25, 1.50, 2.00, 2.50 (25.4, 31.8, 38.1, 50.8, 63.5)	1

**Bottom Endwall**

Knockout Size Dimensions in Inches (mm)	Quantity
0.31 (7.9)	1
0.50 (12.7)	1
0.50, 0.75, 1.00, 1.25, 1.50, 2.00, 2.50 (12.7, 19.1, 25.4, 31.8, 38.1, 50.8, 63.5)	2
1.00, 1.25, 1.50, 2.00, 2.50, 3.00 (25.4, 31.8, 38.1, 50.8, 63.5, 76.2)	1

**Notes**

- ① For details regarding quantities, please contact the Technical Resource Center (TRC) at 1-877-ETN-CARE.
- ② Use when DS H1 Type 1, 1.25 and 1.50-inch hubs are needed.



Systems for Residential and Commercial Applications



### Systems for Residential and Commercial Applications

#### Product Description

Group metering is a service entrance product line that consists of a main device and multiple meter sockets in one enclosure or several connected enclosures. Group metering allows the customer to install a multiple tenant-metering device in one location while providing a space and installation cost savings.

#### Application Description

Eaton’s Electrical Sector offers two group metering designs—Meter Packs and Gangable Metering. Meter Packs, also called All-in-Ones, consist of main lugs and up to six meter sockets in one enclosure. Meter Packs are supplied as one complete unit and the user cannot “add” additional meter sockets to the unit in the future. The most common application for Meter Packs is garden apartments, small condominiums and townhouses where six or less units are metered through one centrally located Meter Pack.

### Contents

<i>Description</i>	<i>Page</i>
Systems for Residential and Commercial Applications	
Features, Benefits and Functions . . . . .	<b>V1-T4-69</b>
Dimensions . . . . .	<b>V1-T4-75</b>
Meter Packs . . . . .	<b>V1-T4-76</b>
Meter Packs—Tenant Circuit Breakers . . . . .	<b>V1-T4-88</b>
Main Service Modules . . . . .	<b>V1-T4-89</b>
Residential Meter Stacks . . . . .	<b>V1-T4-108</b>
Commercial Meter Stack Modules . . . . .	<b>V1-T4-123</b>
35MM, 37MM, 35SS and 37SS Tenant Main Circuit Breakers . . . . .	<b>V1-T4-130</b>
Phase Balanced Stack . . . . .	<b>V1-T4-132</b>
Group Metering Inline Current Transformer Cabinets . . . . .	<b>V1-T4-133</b>
Surge Metering . . . . .	<b>V1-T4-134</b>
Group Metering Accessories . . . . .	<b>V1-T4-135</b>

#### Standards and Certifications

- UL listed



#### ***Gangable Metering (Main Service Modules and Meter Stacks)***

The second type of group metering is Gangable Metering, which consists of a Main Service Module used in conjunction with a Meter Stack to make a custom metering lineup. The Main Service Module can be main lug, main circuit breaker, main fusible switch or bolted pressure switch. The Meter Stack is offered with various meter sockets and bus ratings. This type of custom lineup allows the owner to add/remove meter sockets and main devices to meet future need. Gangable Metering is often used in large condominiums, strip malls and light commercial applications where more than six units are metered, or there will be a future need to add more units.

**Features, Benefits and Functions**

**Bypass Mechanisms**

**Cotter Pin**



Eaton’s metering socket for 1MP, 1MM, 3MM metering devices employ cotter pins on the front and back of the socket jaws for increased durability during performed maintenance on the meters. This component uses jaws on both sides of the base eliminating the need for self-tapping screw connections to vertical busbars.

**Horn and Manual Bypass**



With an increasing demand for uninterrupted power, Eaton’s series of 1MP, 1MM and 3MM meter sockets offer horn (ringless style) and manual (ring style) field-installable bypass accessories. These accessories provide uninterrupted tenant service if a meter is pulled for inspection or replacement.

Horn bypass kits are compatible with ring-less meter sockets for type MB and CMB units and are ANSI/UL Listed.

**Lever Bypass**



Due to commercial requirements, Eaton offers a lever bypass (as standard) on all 35MM and 37MM devices. Each socket base consists of a lever bypass, which also releases the jaws (when lever is engaged in bypass position), enabling utility company mechanics to easily remove and/or insert utility meter.

**Test Bypass Disconnects**



Eaton also provides commercial meter stacks with EUSERC required test-bypass disconnects (35SS and 37SS). This bypass is used in the same applications as the lever bypass and it is required by EUSERC utilities.

**Busing and Meter Socket Field Phase Balancing**



Due to popular incoming three-phase voltage systems and single-phase outgoing loads, installers have the option to field phase balance on the individual stack (A-B, B-C, A-C). This feature eliminates the chance of installing an incorrectly phased device due to its versatility.

**One-Piece Vertical Busbar**



Eaton’s series of 1MP, 1MM, 3MM meter stacks embody a one-piece busbar construction to each socket, as well as a one-piece cross bus to each tenant main. Because the Eaton design uses the Clip-Tight meter socket and does not have busbar joints, the chance of hot spots occurring is virtually eliminated.

**Mounting and Security**

**Main Tenant Breaker Cover**



Each tenant circuit breaker is protected by a lockable raintight cover that secures the breaker against unauthorized operation. The tenant breaker cover is a high impact plastic to resist wear, rusting and corrosion.

**Mounting Features**



A standard mounting rail and factory-installed swing away feet speed up and simplify installation.

#### General

When tenant breakers are installed in Eaton’s metering modules per the short-circuit current ratings below, the branch breakers installed in downstream panel rated 10 kAIC or greater are protected to the listed series AIC rating. Refer to the downstream panel marking for the proper series combination short-circuit ratings. These ratings apply to both loadcenter Types BR and CH.

The short-circuit rating is limited to the lowest interrupting rating of any tenant breaker installed or to the lowest marked interrupting rating of the main switch, main breaker or main lug modules.

Replacement or additional breakers shall be of the same type and manufacturer, and shall have an interrupting rating equal to or greater than the interrupting rating of any tenant breaker presently installed in the meter module.

#### 1MM, 3MM 125 A Meter Module

When used with main switch, main breaker or main lug modules, this meter module is UL listed for the short-circuit rating at 240 Vac maximum in rms symmetrical amperes per table below.

#### 1MM, 3MM 125 A Meter Module

Tenant Breaker Catalog Number Two-Pole	Amperes Maximum	UL Listed Series Short-Circuit Rating
BRX_____	125	65 kAIC
BRHH_____	125	42 kAIC
BRH_____	125	22 kAIC
BR_____	125	10 kAIC

When Type BRX, BRHH or BRH tenant breakers are installed in this meter module, then breakers rated 10 kAIC or greater installed on the load side of this meter module may be protected for short circuits up to 22 kAIC with Type BRH breakers, 42 kAIC with Type BRHH or 65 kAIC with Type BRX breakers.

See load side breaker panel marking for proper short-circuit current rating.

#### 1MM, 3MM 125 A Meter Module

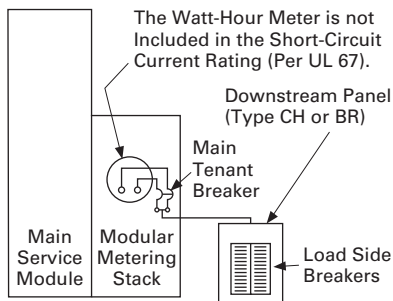

#### 1MM, 3MM, 200 A Meter Modules; 35MM, 37MM, 35SS and 37SS 225 A Meter Modules

When used with main switch, main breaker or main lug modules, these meter modules are UL listed for the short-circuit rating at 240 Vac maximum in rms symmetrical amperes per table below.

#### 1MM, 3MM, 200 A Meter Modules; 35MM, 37MM, 35SS and 37SS 225 A Meter Modules

Tenant Breaker Catalog Number Two- or Three-Pole	Amperes Maximum		
	1MM 3MM 200 A	35MM, 37MM, 35SS, 37SS 225 A	UL Listed Series Short-Circuit Rating
CVH_XMM	200	225	100 kAIC
CV_XMM	200	225	65 kAIC
CVS_XMM	200	225	42 kAIC
CCVH_X	200	225	25 kAIC
CCV_X	200	225	10 kAIC
CC_X	200	225	10 kAIC

When Type CV tenant breakers are installed in these meter modules, then Eaton’s breakers rated 10 kAIC or greater installed on the load side of these meter modules may be protected for short circuits up to 100 kAIC.

See load side breaker panel marking for proper short-circuit current rating.

#### 1MM, 3MM, 200 A Meter Modules; 35MM, 37MM, 35SS and 37SS 225 A Meter Modules

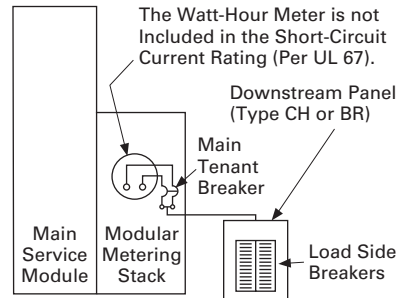

**1MP 125 A Meter Module**

This All-in-One Meter Module is UL listed for the short-circuit rating at 240 Vac maximum in rms symmetrical amperes per table below.

**1MP 125 A Meter Module**

Tenant Breaker Catalog Number Two-Pole	Maximum Ampere Rating	UL Listed Series Short-Circuit Rating
BRX_____	125	65 kAIC
BRHH_____	125	42 kAIC
BRH_____	125	22 kAIC
BR_____	125	10 kAIC

When Type BRX, BRHH or BRH tenant breakers are installed in this meter module, then Eaton’s breakers rated 10 kAIC or greater installed on the load side of this meter module may be protected for short circuits up to 22 kAIC with Type BRH breakers, 42 kAIC with Type BRHH or 65 kAIC with Type BRX breakers.

See load side breaker panel marking for proper short-circuit current rating.

**1MP 125 A Meter Module**

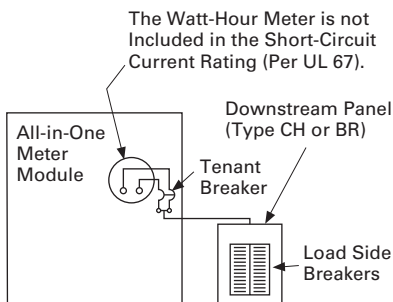

**Note:** The ratings for both 125 and 200 A tenant positions apply to both Type BR and CH loadcenters and 10 kAIC branch breakers.

**1MP 200 A Meter Module**

This All-in-One Meter Module is UL listed for the short-circuit rating at 240 Vac maximum in rms symmetrical amperes per table below.

**1MP 200 A Meter Module**

Tenant Breaker Catalog Number Two- or Three-Pole	Maximum Ampere Rating	UL Listed Series Short-Circuit Rating
CVH_XMM	200	100 kAIC
CV_XMM	200	65 kAIC
CVS_XMM	200	42 kAIC
CCVH_XMM	200	25 kAIC
CCV_X	200	10 kAIC

When Type CV tenant breakers are installed in this meter module, then breakers rated 10 kAIC or greater installed on the load side of this meter module may be protected for short circuits up to 100 kAIC.

See load side breaker panel marking for proper short-circuit current rating.

**1MP 200 A Meter Module**

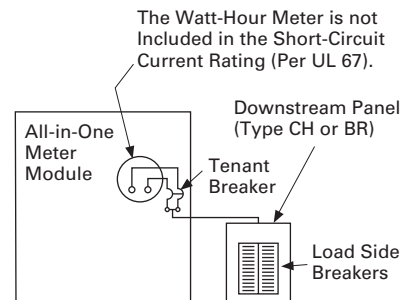

**Ratings**

- A. The assembly shall be rated to withstand mechanical forces exerted during short-circuit conditions when connected directly to a power source having available fault current [22,000] [42,000] [65,000] [100,000] amperes symmetrical at rated voltage.
- C. All hardware used for busbar connections shall be high-tensile strength, zinc-plated. Provide Belleville-type spring washers for all bus joints.
- D. Circuit breakers [250-] [400-] [600-] [1200-] ampere frame and below shall be manufactured by Eaton with thermal-magnetic or electronic trip units having inverse time-current characteristics.

**Construction**

- A. The entire assembly shall be front accessible and shall include [main lugs] [a main disconnect device].
- B. Tenant disconnects shall be wired for cold sequence and shall be molded case circuit breakers.
- C. The meter sockets shall be (ring-) (ringless-) type rated (125 A) (200 A) (as shown on the plans) and a bypass (shall be) (shall not be) required. If required, the bypass shall be a (slider-) (horn-) (lever-) (disconnect block-) type. The meter sockets and associated branch protective device positions shall be completely prewired and shipped ready for installation of the meters and tenant main breakers. Meter sockets shall include covers with sealing positions.

**Bus**

- A. All busbars shall be [tin-plated aluminum or copper]. Main horizontal busbars shall be mounted with all three phases arranged in the same vertical plane. Bus sizing shall be based on UL standard temperature rise criteria for multiple metering equipment.
- B. Provide a full capacity neutral bus where a neutral bus is indicated on the drawings.
- C. All hardware used for busbar connections shall be high-tensile strength, zinc-plated. Provide Belleville-type spring washers for all bus joints.

**Wiring/Terminations**

- A. [Mechanical-type terminals] [Crimp-type termination provisions] shall be provided for all line terminations suitable for copper or aluminum cable and rated at 75 °C.
- B. Lugs shall be provided in the incoming line section for connection of the main grounding conductor.

**Main Circuit Protective Devices**

- A. Main protective devices shall be [molded case circuit breakers] [bolted pressure switches] [quick-make/quick-break fusible switches].

**Molded Case Circuit Breakers**

- A. [Main] [Feeder] [All] protective devices shall be molded case circuit breakers with inverse time and instantaneous tripping characteristics.
- B. Circuit breakers shall be operated by a toggle-type handle and shall have a quick-make/quick-break over-center switching mechanism that is mechanically trip-free. Automatic tripping of the breaker shall be clearly indicated by the handle position. Contacts shall be nonwelding silver alloy and arc extension shall be accomplished by means of DE-ION® arc chutes.
- C. Circuit breakers shall have a minimum symmetrical interrupting capacity as indicated on the drawings.

**Bolted Pressure Switches**

- A. Main protective devices shall be bolted pressure contact type and shall be UL listed.
- B. Fusible switches shall be furnished with Class L fuse clips. Switch contact interrupting capacity shall be 12 times the continuous rating of the switch.
- C. Fuse access door s shall be mechanically interlocked with the operating handle and shall have provisions for padlocking the switch in the OPEN position.
- D. The switch shall use a stored energy deadfront operating mechanism compressed and released by the operating handle, to provide quick positive switching action, independent of the operating handle.
- E. Switches shall be manually operated.

**Quick-Make/Quick-Break Fusible Switches**

- A. Fusible switches 30 A through 1200 A frames shall be furnished with 300 V Class T-type fuse clips unless otherwise scheduled.
- B. Switches shall incorporate safety cover interlocks to prevent opening the cover with the switch in the ON position.
- C. Provide defeater for authorized personnel.

- D. Handles shall have provisions for padlocking and shall clearly indicate the ON or OFF position.
- E. Front cover doors shall be padlockable in the CLOSED position.
- F. Main protective devices shall be quick-make/quick-break fusible switches as manufactured by Eaton.

**Tenant Utility Metering**

- A. For EUSERC serviced areas, meter centers shall incorporate metering sections with tenant feeder circuits using ring-type meter sockets rated [125] [200] amperes to meet local utility and/or customer requirements.
- B. The self-contained meter sockets shall include a test bypass/disconnect block per EUSERC requirements,
  - OR –
- A. For non-EUSERC serviced areas, meter centers shall incorporate metering sections with tenant feeder circuits using [ring-] [ringless-] type meter sockets rated [125] [200] [320] amperes to meet local utility or customer requirements. Provide meter sockets with individual covers having sealing provisions.
- B. Meter sockets shall have manual bypass and optional internal barriers.

**Enclosures**

- A. NEMA 1 Enclosure
  - OR –
- A. Outdoor NEMA 3R Surface-Mounted Enclosure

**Finish**

- A. Boxes and trims shall be bonderized and finished with ANSI 61 light gray enamel.

**Series Combination Short-Circuit Ratings**

When main tenant breakers are installed in Eaton’s modular metering stack, the branch breakers installed in downstream panel rated 10 kAIC or greater are protected to the listed series AIC rating. Refer to the downstream panel marking for the proper series combination short-circuit ratings.

Replacement or additional breakers shall be of the same manufacture and type, and shall have an interrupting rating equal to or greater than the interrupting rating of any main tenant breaker installed.

**Series Combination Short-Circuit Ratings**

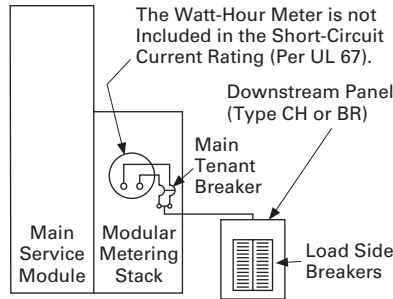

**Series Combination Short-Circuit Ratings—240 Vac**

Main Module Overcurrent Device Breaker Type or Class Fuse	System AIC Rating 120/240 Vac Maximum	Meter Module Tenant Feeder Breaker Type 1MM, 3MM, 35MM, 37MM, 35SS, 37SS or Loadcenter Main Breaker	Tenant Feeder Breaker Short-Circuit Rating	Loadcenter Branch Breaker (Single-, Two- or Three-Pole)
None	10,000	None	—	BD, BR, BRD, BQ, BQC, BRCAF, GFTCB
Without main disconnect. Cable tap box Type 1MTB_, 3MTB_	10,000 22,000	BR, CC, BW, CCV BRH	10,000 22,000	
Main switch module, Type 1MFS, 3MFS and 1BPS, 3BPS	25,000 42,000	CSR, CCVH BRHH, CVS	25,000 42,000	
Main breaker module, Type 1MCB, 3MCB	65,000 100,000	BRX, CV, KD, HKD CVH, KDC	65,000 100,000	
Without main disconnect. Cable tap box Type 1MTB_, 3MTB_	10,000 22,000	BR, CC, BW, CCV BRH	10,000 22,000	BD, BR, BRD, BQ, BQC, CH, CHT, BRCAF, CHFCAF, CHF, CH-GFCI, GFTCB
Main switch module, Type 1MFS, 3MFS and 1BPS, 3BPS	25,000 42,000	CSR, CCVH BRHH, CVS	25,000 42,000	
Main breaker module, Type 1MCB, 3MCB	65,000	BRX, CV, KD, HKD	65,000	
Main breaker module Type 1MCB_, 3MCB_ 2000 A maximum	65,000	BRHX	22,000	BR, BRAFGF
Main switch module Type 1MFS_, 3MFS_ with Class T fuse, 600 A maximum	100,000	BRH	22,000	BD, BR, BRD, BQ, BQC, GFCB, GFTCB
Main switch module Type 1MFS_, 3MFS_ with Class T fuse, 1200 A maximum	100,000	BRHH	42,000	BD, BR, BRD, BQ, BQC, CH, CHT, BRCAF, CHFCAF, CHF, GFTCB

### Phase Balancing

4

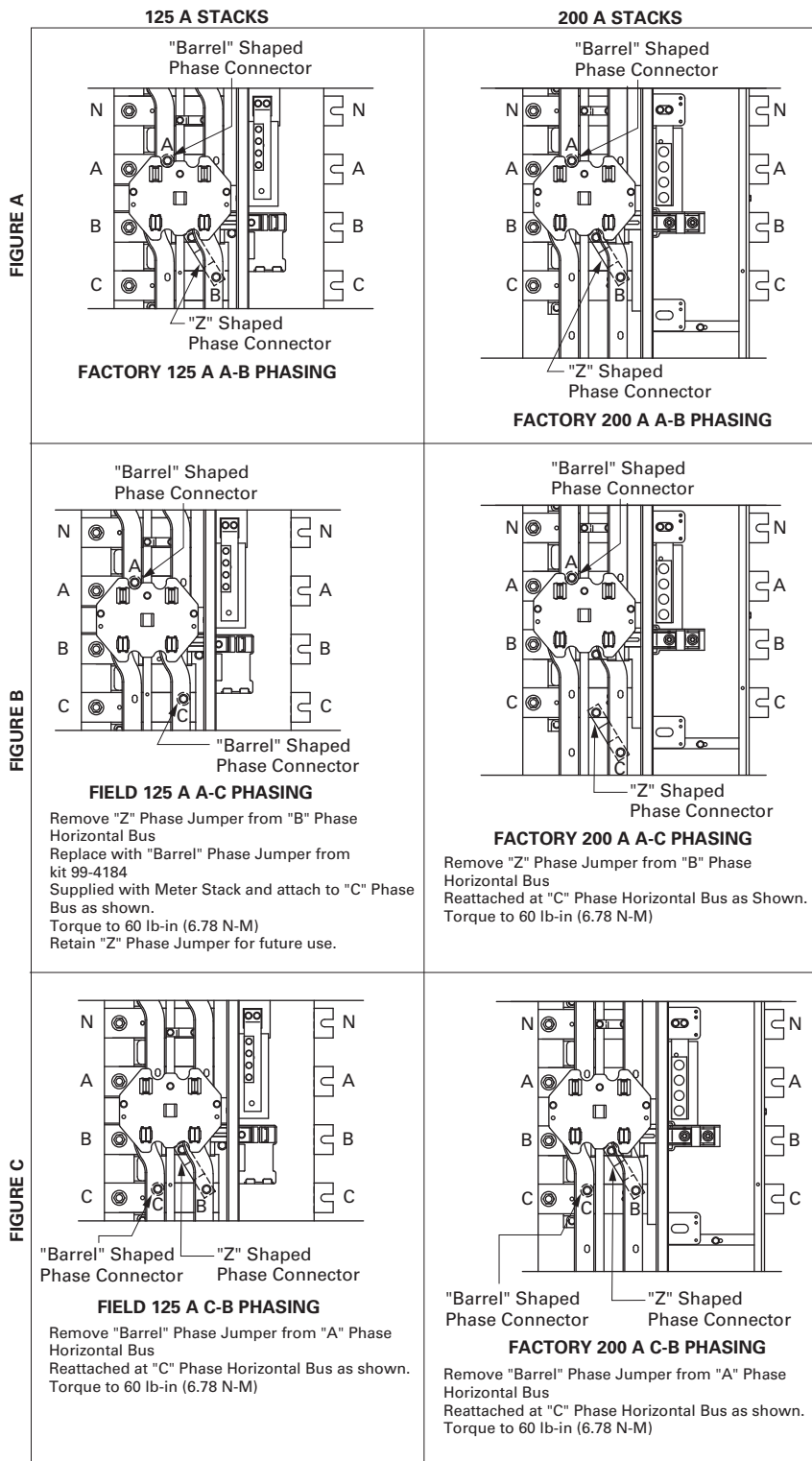

**Dimensions**

Approximate Dimensions in Inches (mm)

**General Layout**

Minimum and maximum height of single-phase and three-phase meter sockets above typical ground level.

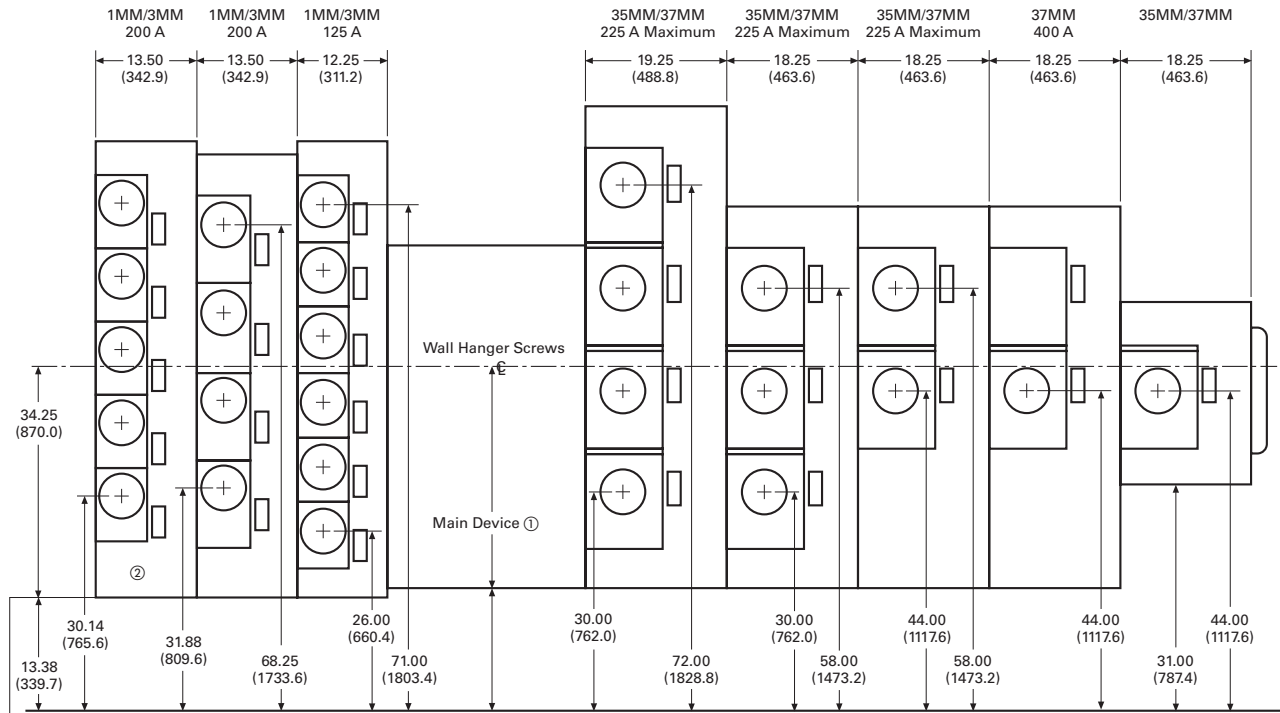

Typical Height Above Ground or Floor Level

**Mounting Features**



**Mounting Features**

A standard mounting rail and factory-installed swing away feet, speed up and simplify installation.

**Notes**

- ① Not a constant value. Dimension changes depending on main device chosen. See **Page V1-T4-103** for specific dimensions.
- ② Residential device.



Meter Pack



### Contents

<b>Description</b>	<b>Page</b>
Systems for Residential and Commercial Applications . . . . .	<b>V1-T4-68</b>
Meter Packs	
Catalog Number Selection . . . . .	<b>V1-T4-77</b>
Product Selection . . . . .	<b>V1-T4-78</b>
Dimensions and Knockouts . . . . .	<b>V1-T4-80</b>
Meter Packs—Tenant Circuit Breakers . . . . .	<b>V1-T4-88</b>
Main Service Modules . . . . .	<b>V1-T4-89</b>
Residential Meter Stacks . . . . .	<b>V1-T4-108</b>
Commercial Meter Stack Modules . . . . .	<b>V1-T4-123</b>
35MM, 37MM, 35SS and 37SS Tenant Main Circuit Breakers . . . . .	<b>V1-T4-130</b>
Phase Balanced Stack . . . . .	<b>V1-T4-132</b>
Group Metering Inline Current Transformer Cabinets . . . . .	<b>V1-T4-133</b>
Surge Metering . . . . .	<b>V1-T4-134</b>
Group Metering Accessories . . . . .	<b>V1-T4-135</b>

### Meter Packs

#### Product Overview

- Eaton's 1MP units are self-contained (main terminal box included) for installations requiring up to six meter socket positions in a single enclosure
- Units are not gangable with any other metering device
- Approved by major power companies, UL listed, suitable as service equipment and meet the service and electrical requirements of EUSERC and CECHA
- Series rating up to 100 kAIC
- All ringless cover devices include fifth jaw as standard
- Ring type devices do not include fifth jaw as standard. Order 1MM5JK if needed
- Bondable neutral
- 120/240 Vac, single-phase three-wire metering device
- Up to 600 A maximum horizontal bus rating
- Incoming lugs not included (phase A, phase B and neutral)
- Indoor/outdoor construction
- Provision for two-pole breaker (plug-on type for 125 A sockets and bolt-on type for 200 A sockets)—circuit breakers not included
- Underground incoming feed
- Aluminum or copper bus

**Catalog Number Selection**

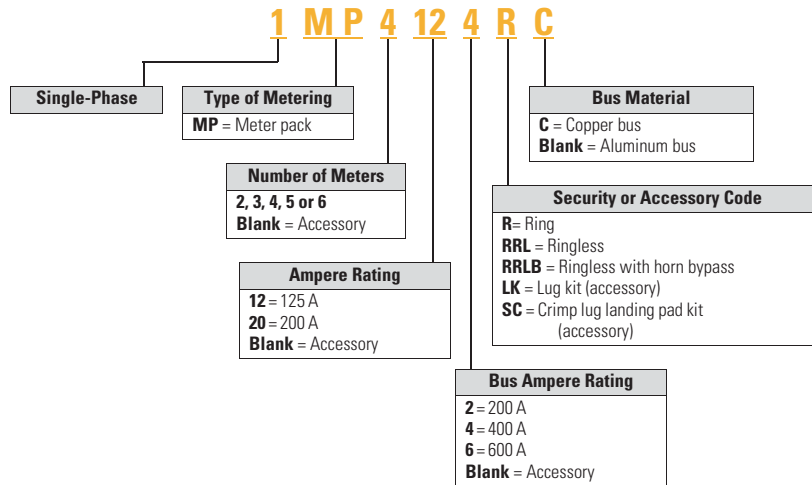

**When Ordering:**

1. Determine catalog number of the basic device.
2. Include Lug Kit for incoming section. See **Page V1-T4-141**.
3. Find quantity and catalog numbers for tenant circuit breakers. (Order one breaker per socket.) See **Page V1-T4-141**.
4. Select required accessories. See **Page V1-T4-136**.

#### Product Selection

##### Meter Packs

##### Aluminum Bus—Main Lugs Not Included—See Page V1-T4-141

Socket Ampere Rating	Number of Meter Sockets	Bus Ampere Rating	Main Tenant Breaker Type (See Page V1-T4-141)	Catalog Number	Semi-Flush Flange Kit Catalog Number
<b>Ring Style Meter Socket Covers <sup>①②</sup></b>					
125 <sup>③</sup>	2 <sup>⑤</sup>	200	Plug-on type BR2_	<b>1MP2122R</b> <sup>⑥⑨</sup>	<b>1MP5FK1</b>
125 <sup>③</sup>	3	400	BRH2_	<b>1MP3124R</b> <sup>⑦</sup>	<b>1MP5FK2</b>
125 <sup>③</sup>	4	400	BRHH2_	<b>1MP4124R</b> <sup>⑦</sup>	<b>1MP5FK2</b>
125 <sup>③</sup>	5 <sup>⑤</sup>	600	BRX2_	<b>1MP5126R</b> <sup>⑦</sup>	<b>1MP5FK3</b>
125 <sup>③</sup>	6 <sup>⑤</sup>	600		<b>1MP6126R</b> <sup>⑦</sup>	<b>1MP5FK3</b>
200 <sup>④</sup>	2	400	Bolt-on type CCV2_X	<b>1MP2204R</b> <sup>⑦</sup>	<b>1MP5FK4</b>
200 <sup>④</sup>	3	600	CCVH2_X	<b>1MP3206R</b> <sup>⑦</sup>	<b>1MP5FK5</b>
200 <sup>④</sup>	4	600	CVS2_XMM	<b>1MP4206R</b> <sup>⑦</sup>	<b>1MP5FK5</b>
200 <sup>④</sup>	5	600	CV2_XMM	<b>1MP5206R</b> <sup>⑦</sup>	<b>1MP5FK6</b>
200 <sup>④</sup>	6	600	CVH2_XMM	<b>1MP6206R</b> <sup>⑦</sup>	<b>1MP5FK6</b>
<b>Ringless Style Meter Socket Covers <sup>⑧</sup></b>					
125	2	200	Plug-on type BR2_	<b>1MP2122RRL</b> <sup>⑥⑨</sup>	<b>1MP5FK1</b>
125	3	400	BRH2_	<b>1MP3124RRL</b> <sup>⑦</sup>	<b>1MP5FK2</b>
125	4	400	BRHH2_	<b>1MP4124RRL</b> <sup>⑦</sup>	<b>1MP5FK2</b>
125	5	600	BRX2_	<b>1MP5126RRL</b> <sup>⑦</sup>	<b>1MP5FK3</b>
125	6	600		<b>1MP6126RRL</b> <sup>⑦</sup>	<b>1MP5FK3</b>
200	2	400	Bolt-on type CCV2_X	<b>1MP2204RRL</b> <sup>⑦</sup>	<b>1MP5FK4</b>
200	3	600	CCVH2_X	<b>1MP3206RRL</b> <sup>⑦</sup>	<b>1MP5FK5</b>
200	4	600	CVS2_XMM	<b>1MP4206RRL</b> <sup>⑦</sup>	<b>1MP5FK5</b>
200	5	600	CV2_XMM	<b>1MP5206RRL</b> <sup>⑦</sup>	<b>1MP5FK6</b>
200	6	600	CVH2_XMM	<b>1MP6206RRL</b> <sup>⑦</sup>	<b>1MP5FK6</b>
<b>Ringless Style Covers with Horn Bypass <sup>⑩</sup></b>					
125	2	200	Plug-on type BR2_	<b>1MP2122RRLB</b> <sup>⑥⑦</sup>	<b>1MP5FK1</b>
125	3	400	BRH2_	<b>1MP3124RRLB</b> <sup>⑨⑩</sup>	<b>1MP5FK2</b>
125	4	400	BRHH2_	<b>1MP4124RRLB</b> <sup>⑨⑩</sup>	<b>1MP5FK2</b>
125	5	600	BRX2_	<b>1MP5126RRLB</b> <sup>⑨⑩</sup>	<b>1MP5FK3</b>
125	6	600		<b>1MP6126RRLB</b> <sup>⑨⑩</sup>	<b>1MP5FK3</b>
200	2	400	Bolt-on type CCV2_X	<b>1MP2204RRLB</b> <sup>⑨⑩</sup>	<b>1MP5FK4</b>
200	3	600	CCVH2_X	<b>1MP3206RRLB</b> <sup>⑨⑩</sup>	<b>1MP5FK5</b>
200	4	600	CVS2_XMM	<b>1MP4206RRLB</b> <sup>⑨⑩</sup>	<b>1MP5FK5</b>
200	5	600	CV2_XMM	<b>1MP5206RRLB</b> <sup>⑨⑩</sup>	<b>1MP5FK6</b>
200	6	600	CVH2_XMM	<b>1MP6206RRLB</b> <sup>⑨⑩</sup>	<b>1MP5FK6</b>

#### Notes

- ① Ring Style Meter Packs do not come with fifth jaw. Order **1MM5JK** if needed.
- ② Reference drawing EUSERC DWG-342, G1.
- ③ To change in field from ring to ringless—order **1MMRC125**.
- ④ To change in field from ring to ringless—order **1MMRC200**.
- ⑤ To change from ring to ringless covers, the top socket only in 2, 5 and 6 socket designs—order **1MMRC125T**. Top socket only.
- ⑥ Main lugs included. #6–300 kcmil. (Optional lugs are not available.)
- ⑦ For overhead use, order DS\_H2 type hub.
- ⑧ Fifth jaw factory installed at 9 o'clock position.
- ⑨ For overhead use, order DS\_MH type hub.
- ⑩ To order with raceway provision in bottom endwall, add "T" suffix to the catalog number. Trough accessory catalog number is **1008934CH**.

See **Page V1-T4-141** for Main Lug Kit selection and Wire Sizes.

**Copper Bus—Main Lugs Not Included—See Page V1-T4-141**

Socket Ampere Rating	Number of Meter Sockets	Bus Ampere Rating	Main Tenant Breaker Type (See Page V1-T4-141)	Catalog Number	Semi-Flush Flange Kit Catalog Number
<b>Ring Style Meter Socket Covers <sup>①②</sup></b>					
125 <sup>③</sup>	2 <sup>④</sup>	200	Plug-on type BR2_	<b>1MP2122RC <sup>⑦</sup></b>	<b>1MPSFK1</b>
125 <sup>③</sup>	3	400	BRH2_	<b>1MP3124RC <sup>⑧</sup></b>	<b>1MPSFK2</b>
125 <sup>③</sup>	4	400	BRHH2_	<b>1MP4124RC <sup>⑧</sup></b>	<b>1MPSFK2</b>
125 <sup>③</sup>	5 <sup>⑤</sup>	600	BRX2_	<b>1MP5126RC <sup>⑧</sup></b>	<b>1MPSFK3</b>
125 <sup>③</sup>	6 <sup>⑤</sup>	600		<b>1MP6126RC <sup>⑧</sup></b>	<b>1MPSFK3</b>
200 <sup>④</sup>	2	400	Bolt-on type CCV2_X	<b>1MP2204RC <sup>⑧</sup></b>	<b>1MPSFK4</b>
200 <sup>④</sup>	3	600	CCVH2_X	<b>1MP3206RC <sup>⑧</sup></b>	<b>1MPSFK5</b>
200 <sup>④</sup>	4	600	CVS2_XMM	<b>1MP4206RC <sup>⑧</sup></b>	<b>1MPSFK5</b>
200 <sup>④</sup>	5	600	CV2_XMM	<b>1MP5206RC <sup>⑧</sup></b>	<b>1MPSFK6</b>
200 <sup>④</sup>	6	600	CVH2_XMM	<b>1MP6206RC <sup>⑧</sup></b>	<b>1MPSFK6</b>
<b>Ringless Style Meter Socket Covers <sup>⑥</sup></b>					
125	2	200	Plug-on type BR2_	<b>1MP2122RRLC <sup>⑧</sup></b>	<b>1MPSFK1</b>
125	3	400	BRH2_	<b>1MP3124RRLC <sup>⑧</sup></b>	<b>1MPSFK2</b>
125	4	400	BRHH2_	<b>1MP4124RRLC <sup>⑧</sup></b>	<b>1MPSFK2</b>
125	5	600	BRX2_	<b>1MP5126RRLC <sup>⑧</sup></b>	<b>1MPSFK3</b>
125	6	600		<b>1MP6126RRLC <sup>⑧</sup></b>	<b>1MPSFK3</b>
200	2	400	Bolt-on type CCV2_X	<b>1MP2204RRLC <sup>⑧</sup></b>	<b>1MPSFK4</b>
200	3	600	CCVH2_X	<b>1MP3206RRLC <sup>⑧</sup></b>	<b>1MPSFK5</b>
200	4	600	CVS2_XMM	<b>1MP4206RRLC <sup>⑧</sup></b>	<b>1MPSFK5</b>
200	5	600	CV2_XMM	<b>1MP5206RRLC <sup>⑧</sup></b>	<b>1MPSFK6</b>
200	6	600	CVH2_XMM	<b>1MP6206RRLC <sup>⑧</sup></b>	<b>1MPSFK6</b>
<b>Ringless Style Covers with Horn Bypass <sup>⑥</sup></b>					
125	2	200	Plug-on type BR2_	<b>1MP2122RRLBC <sup>⑧</sup></b>	<b>1MPSFK1</b>
125	3	400	BRH2_	<b>1MP3124RRLBC <sup>⑧</sup></b>	<b>1MPSFK2</b>
125	4	400	BRHH2_	<b>1MP4124RRLBC <sup>⑧</sup></b>	<b>1MPSFK2</b>
125	5	600	BRX2_	<b>1MP5126RRLBC <sup>⑧</sup></b>	<b>1MPSFK3</b>
125	6	600		<b>1MP6126RRLBC <sup>⑧</sup></b>	<b>1MPSFK3</b>
200	2	400	Bolt-on type CCV2_X	<b>1MP2204RRLBC <sup>⑧</sup></b>	<b>1MPSFK4</b>
200	3	600	CCVH2_X	<b>1MP3206RRLBC <sup>⑧</sup></b>	<b>1MPSFK5</b>
200	4	600	CVS2_XMM	<b>1MP4206RRLBC <sup>⑧</sup></b>	<b>1MPSFK5</b>
200	5	600	CV2_XMM	<b>1MP5206RRLBC <sup>⑧</sup></b>	<b>1MPSFK6</b>
200	6	600	CVH2_XMM	<b>1MP6206RRLBC <sup>⑧</sup></b>	<b>1MPSFK6</b>

**Notes**

- ① Ring Style Meter Packs do not come with fifth jaw. Order **1MM5JK** if needed.
- ② Reference drawing EUSERC DWG-342, G1.
- ③ To change in field from ring to ringless—order **1MMRC125**.
- ④ To change in field from ring to ringless—order **1MMRC200**.
- ⑤ To change in field from ring to ringless covers, the top socket only in 5 to 6 socket design—order **1MMRC125T**. Top socket only—other sockets see ③.
- ⑥ Fifth jaw factory installed at 9 o'clock position.
- ⑦ For overhead use, order DS\_H2 type hub.
- ⑧ For overhead use, order DS\_MH type hub.

# 4.3

## Metering Products

### Group Metering

#### Dimensions and Knockouts

Approximate Dimensions in Inches (mm)

#### 1MP, 125 Ampere Meter Packs—Aluminum and Copper Bus (1 of 2)

4

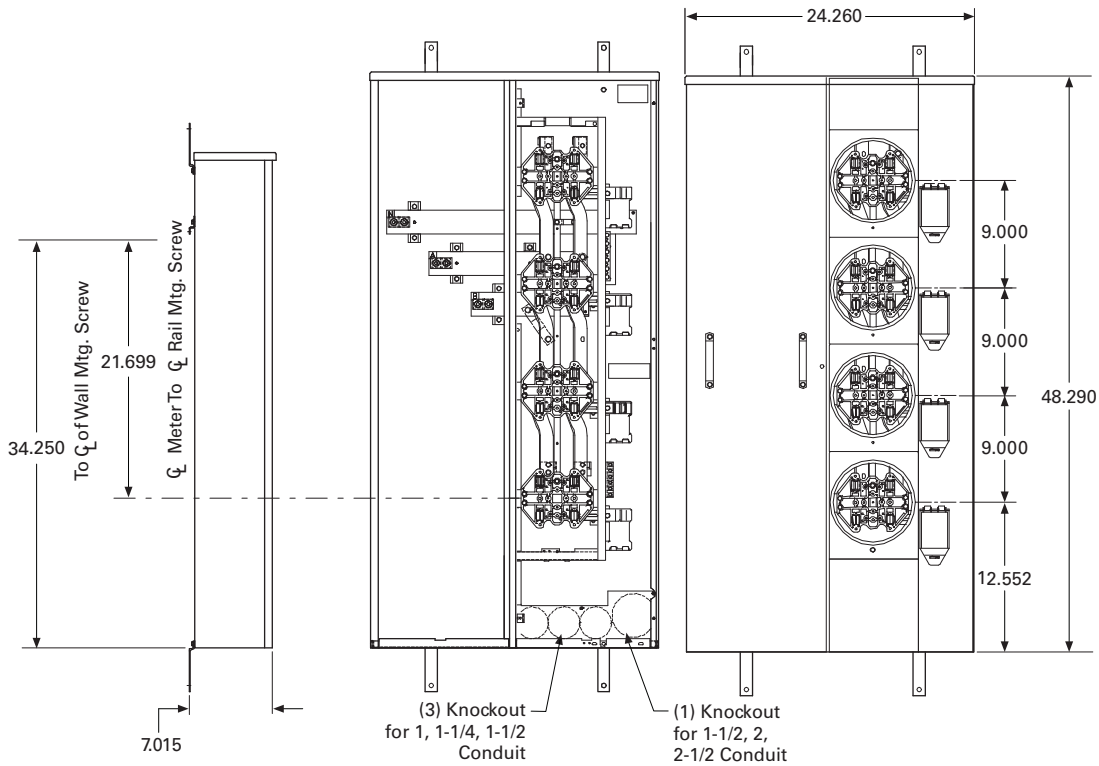

3, 4 Meter Device

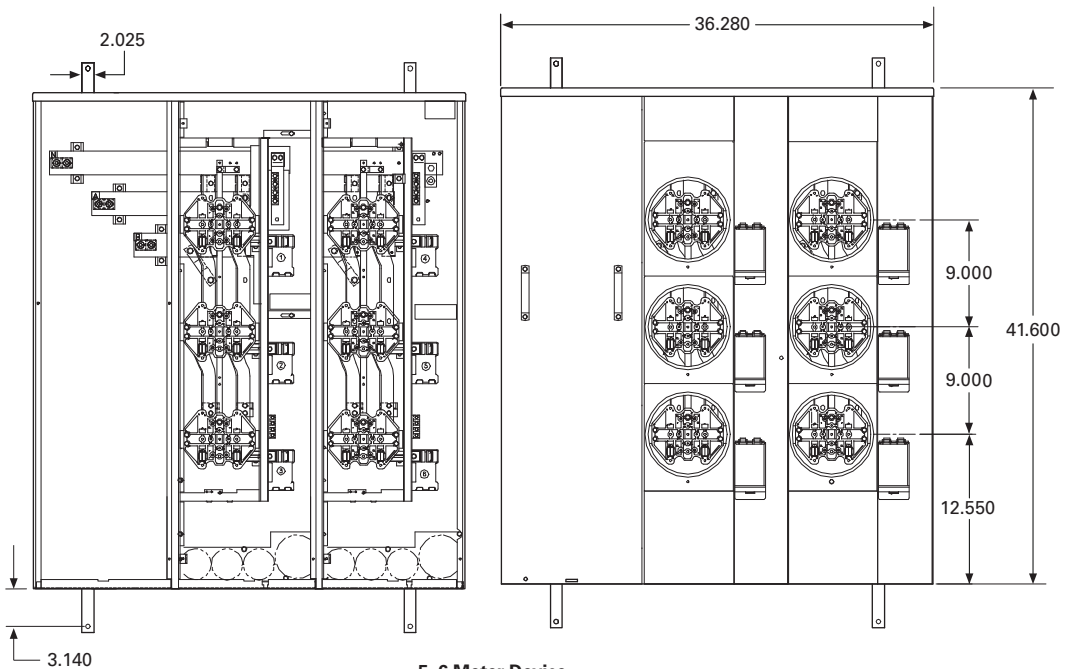

5, 6 Meter Device

Approximate Dimensions in Inches (mm)

1MP, 125 Ampere Meter Packs—Aluminum and Copper Bus (2 of 2)

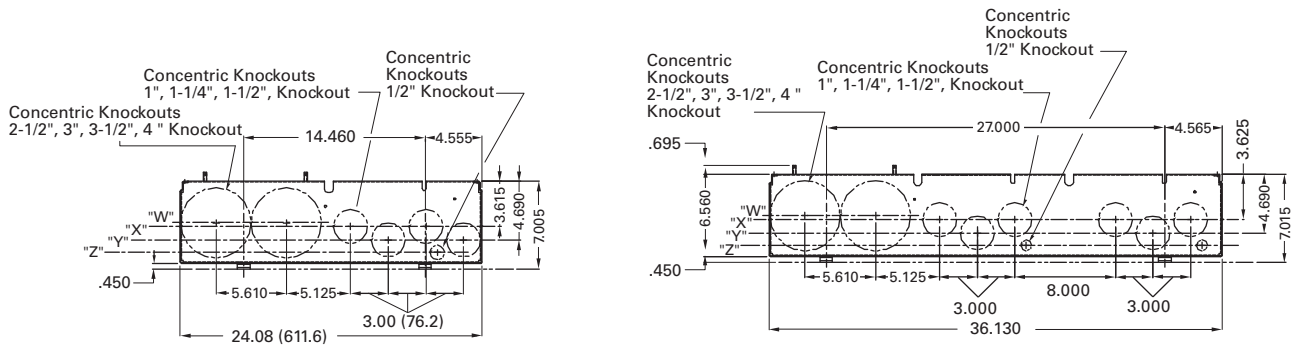

"Z" =  $\text{C}$  of 1/2" Ring  
 "Y" =  $\text{C}$  of 1-1/2" Ring  
 "X" =  $\text{C}$  of 1-1/2" Ring  
 "W" =  $\text{C}$  of 4" Ring

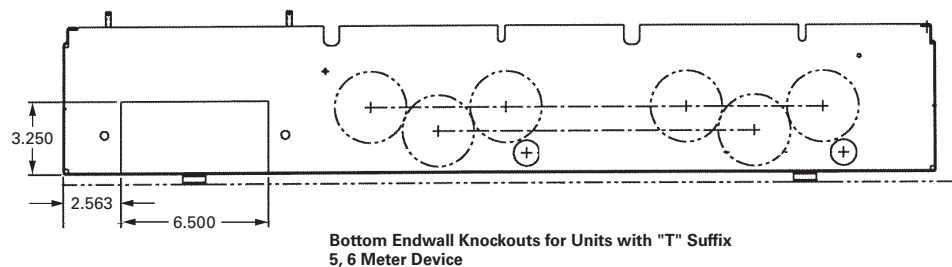
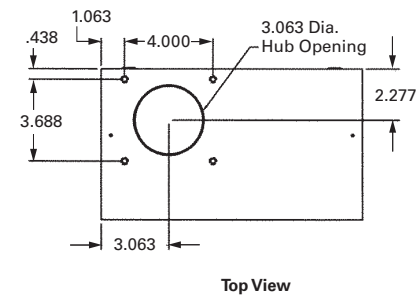
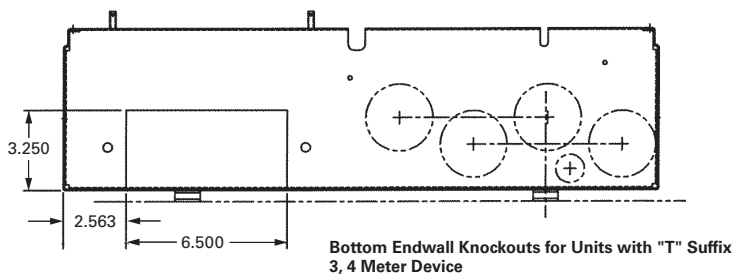
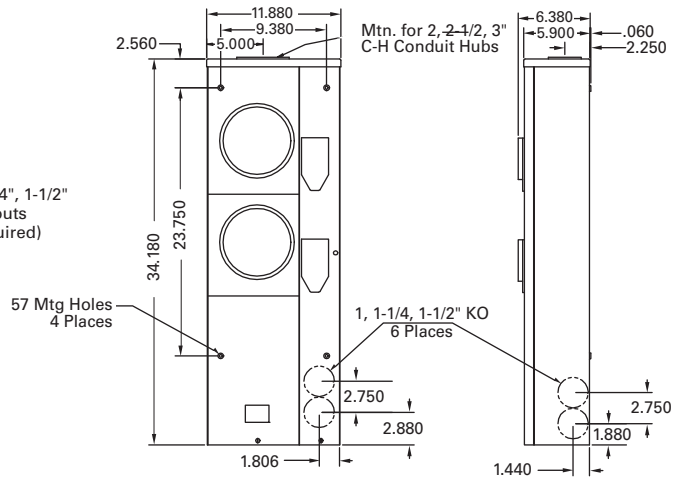
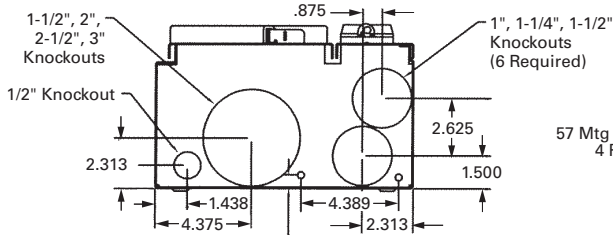

# 4.3

## Metering Products

### Group Metering

Approximate Dimensions in Inches (mm)

#### 1MP, 200 Ampere Meter Packs—Aluminum and Copper Bus (1 of 2)

4

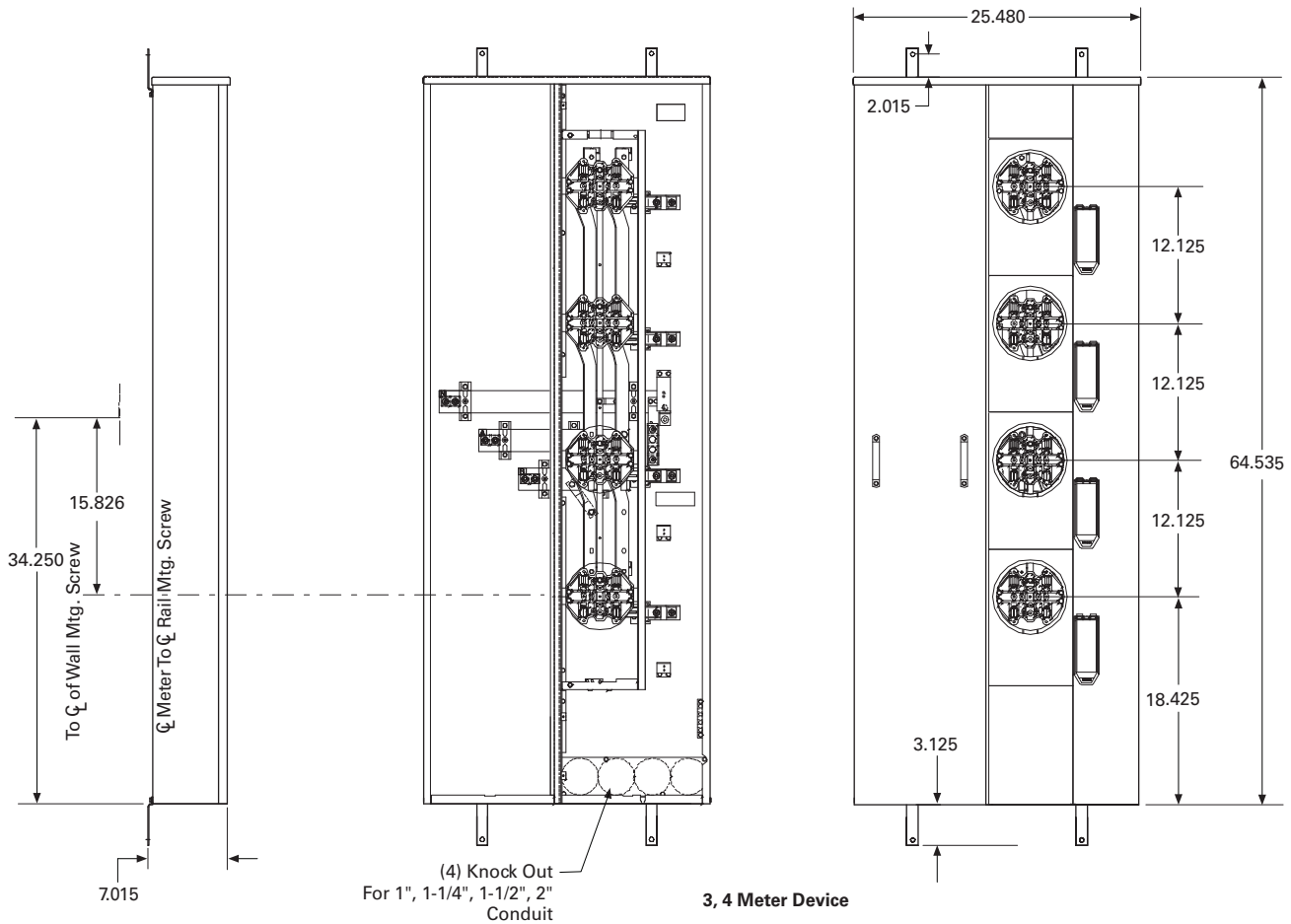
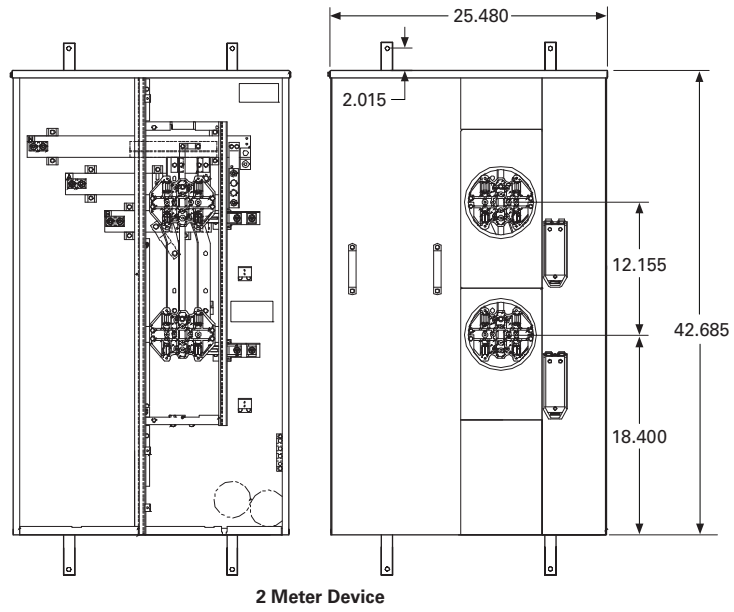

Approximate Dimensions in Inches (mm)

1MP, 200 Ampere Meter Packs—Aluminum and Copper Bus (2 of 2)

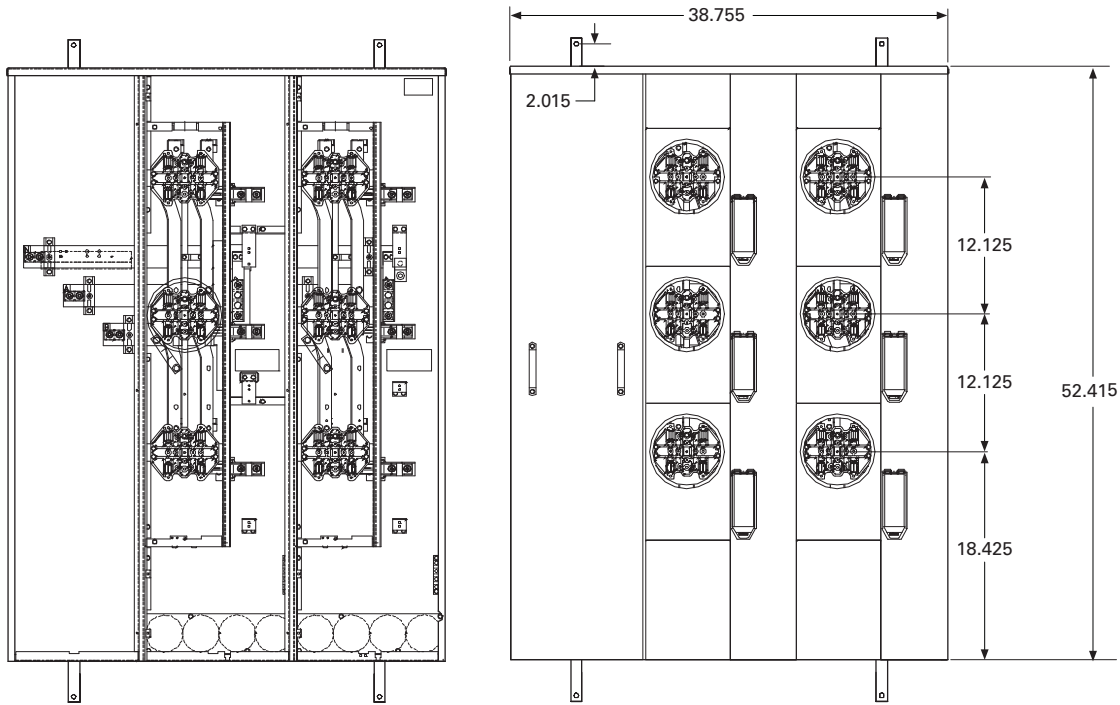

5, 6 Meter Device

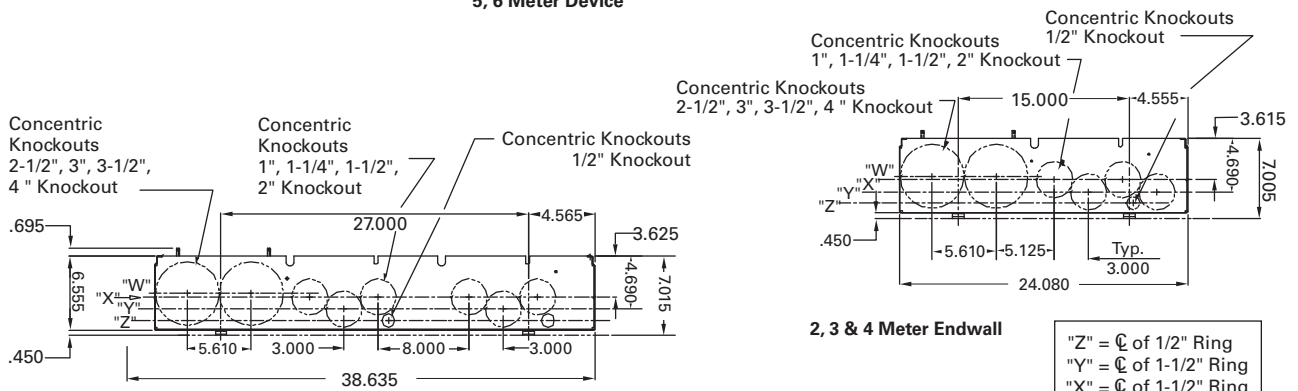

2, 3 & 4 Meter Endwall

"Z" =  $\text{C}$  of 1/2" Ring  
 "Y" =  $\text{C}$  of 1-1/2" Ring  
 "X" =  $\text{C}$  of 1-1/2" Ring  
 "W" =  $\text{C}$  of 4" Ring

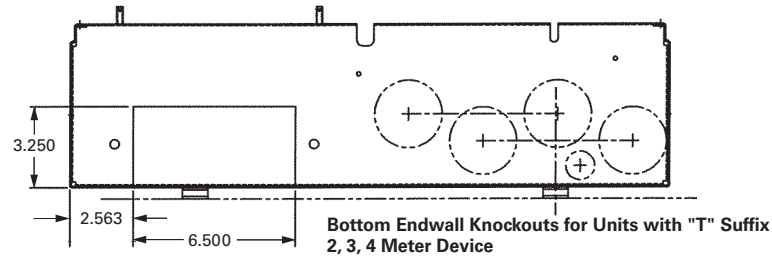

Bottom Endwall Knockouts for Units with "T" Suffix  
 2, 3, 4 Meter Device

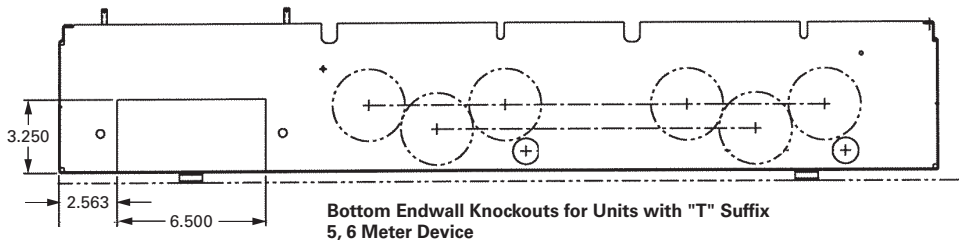

Bottom Endwall Knockouts for Units with "T" Suffix  
 5, 6 Meter Device



# 4.3

## Metering Products

### Group Metering

Approximate Dimensions in Inches (mm)

#### 1MP, 200 Ampere Meter Packs—Aluminum and Copper Bus (2 Meter Device)

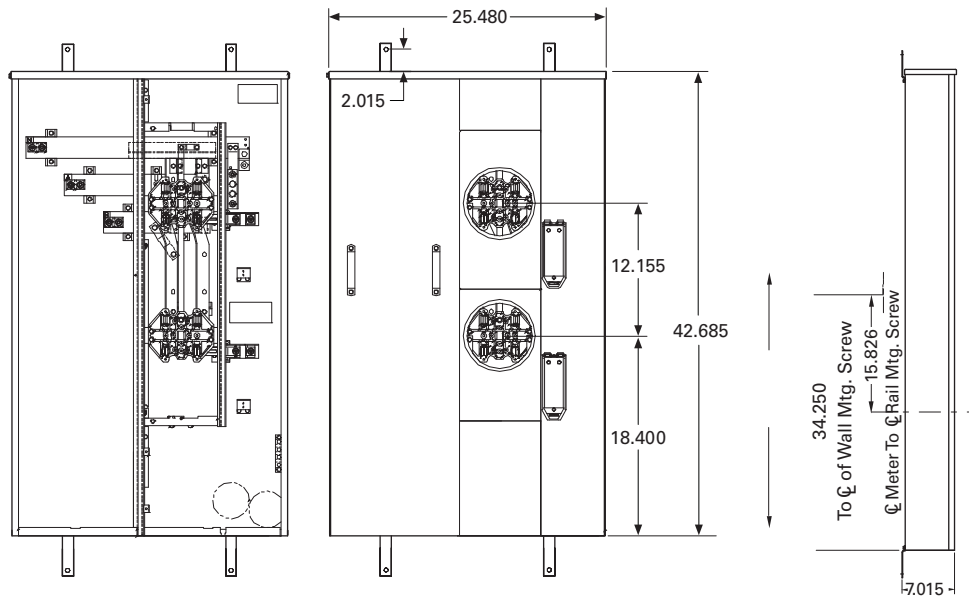

2 Meter Device

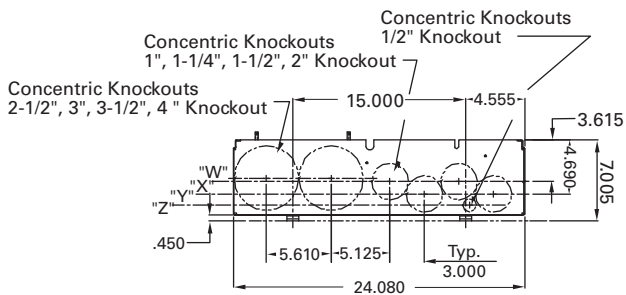

2, 3 & 4 Meter Endwall

"Z" =  $\phi$  of 1/2" Ring  
 "Y" =  $\phi$  of 1-1/2" Ring  
 "X" =  $\phi$  of 1-1/2" Ring  
 "W" =  $\phi$  of 4" Ring

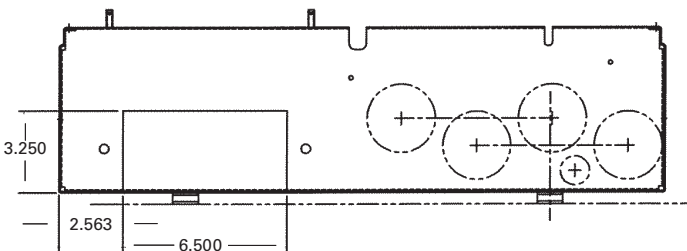
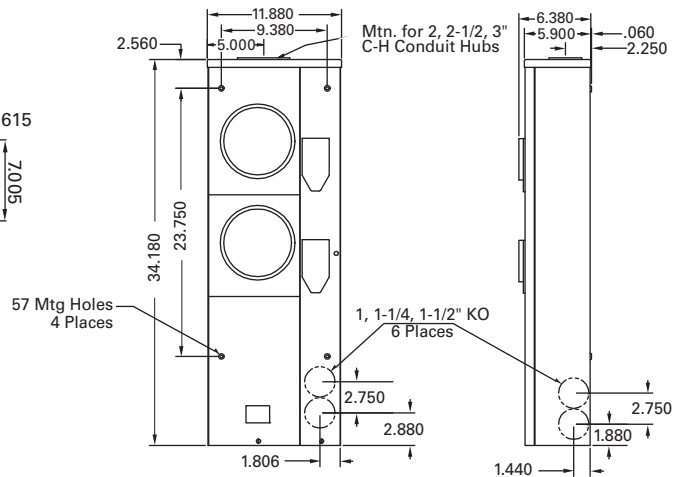

Bottom Endwall Knockouts  
 for Units with "T" Suffix  
 2, 3, 4 Meter Device

Approximate Dimensions in Inches (mm)

### 1MP, 200 Ampere Meter Packs—Aluminum and Copper Bus (3 and 4 Meter Device)

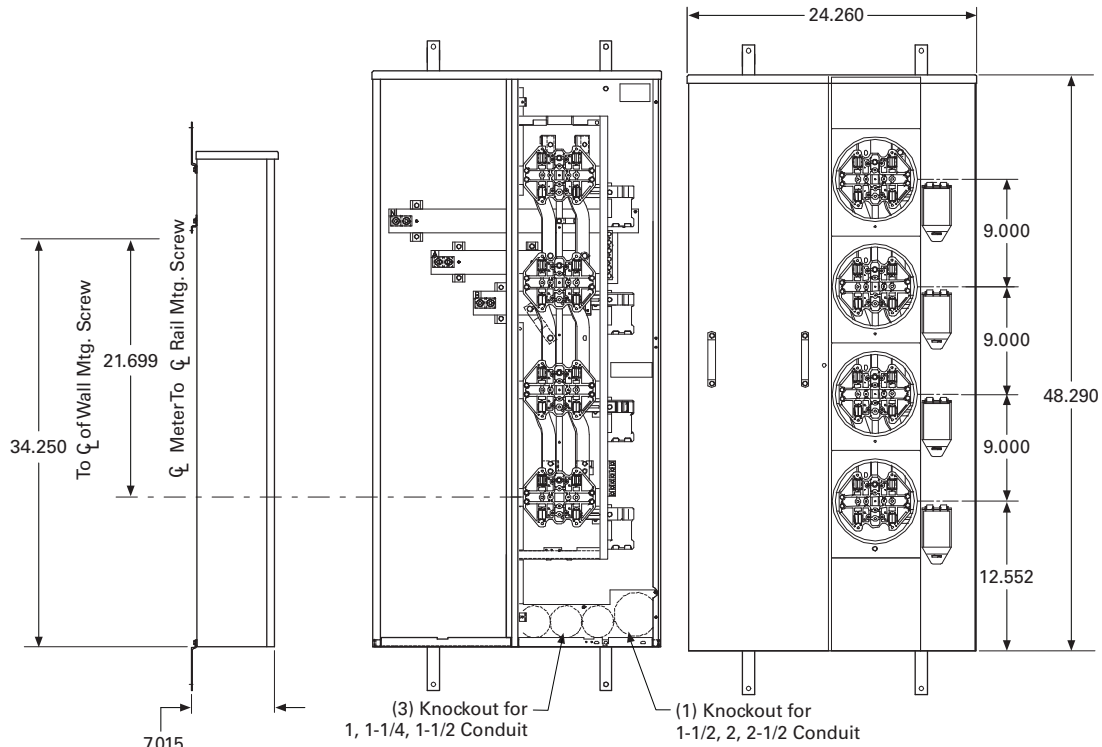

3 and 4 Meter Device

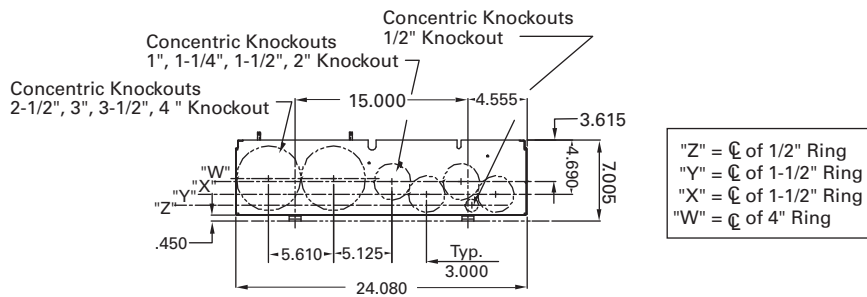

2, 3 & 4 Meter Endwall

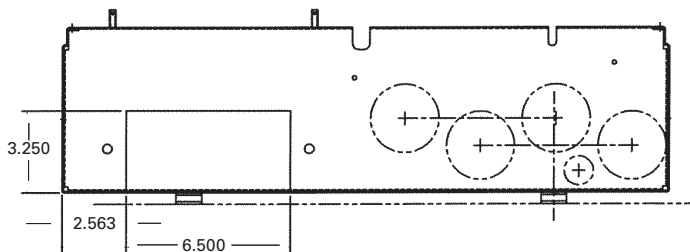

Bottom Endwall Knockouts for Units with "T" Suffix  
2, 3, 4 Meter Device

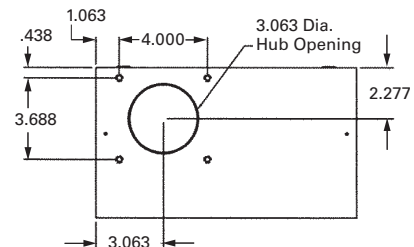

Top View

# 4.3

## Metering Products

### Group Metering

Approximate Dimensions in Inches (mm)

#### 1MP, 200 Ampere Meter Packs—Aluminum and Copper Bus (5 and 6 Meter Device) 1 of 2

4

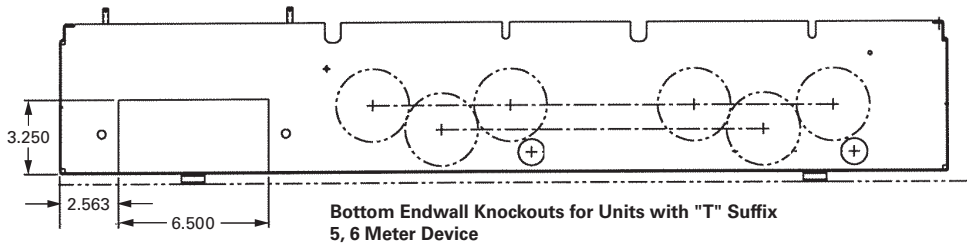
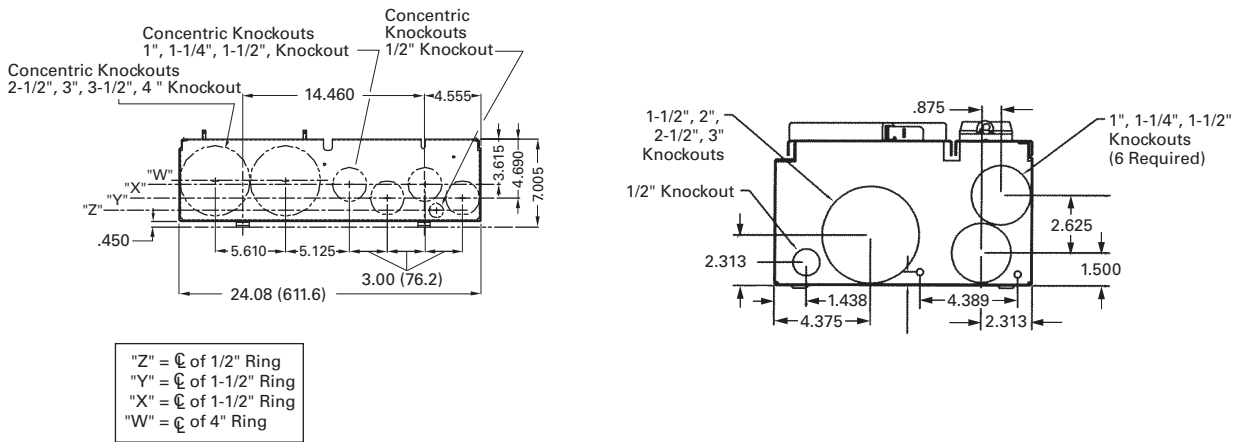
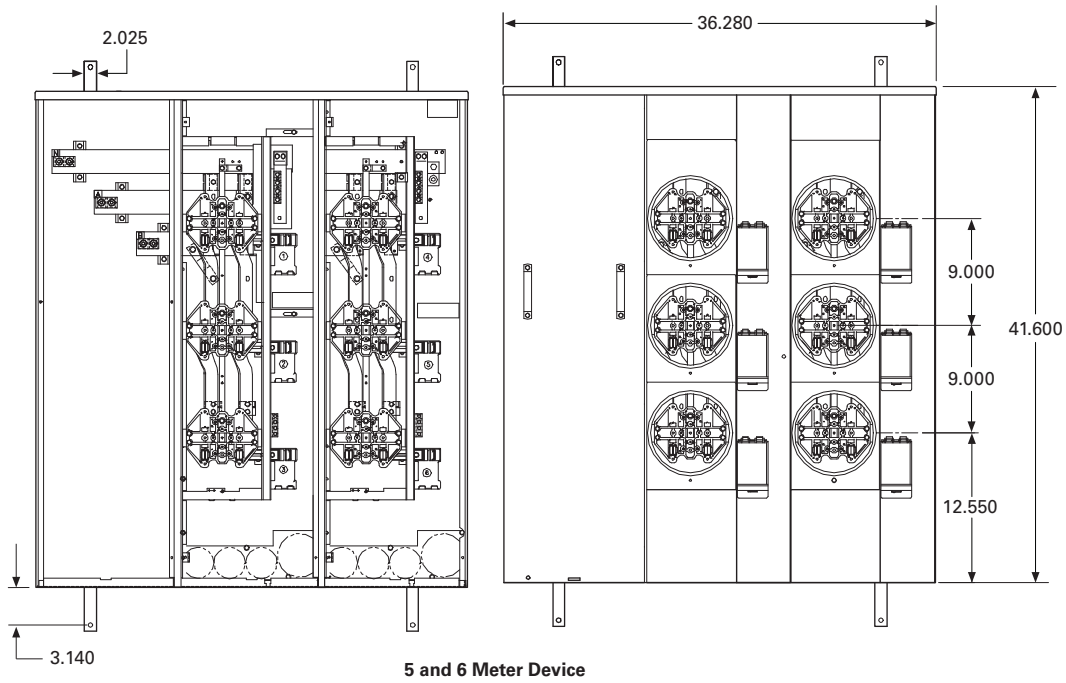

Approximate Dimensions in Inches (mm)

**1MP, 200 Ampere Meter Packs—Aluminum and Copper Bus (5 and 6 Meter Device) 2 of 2**

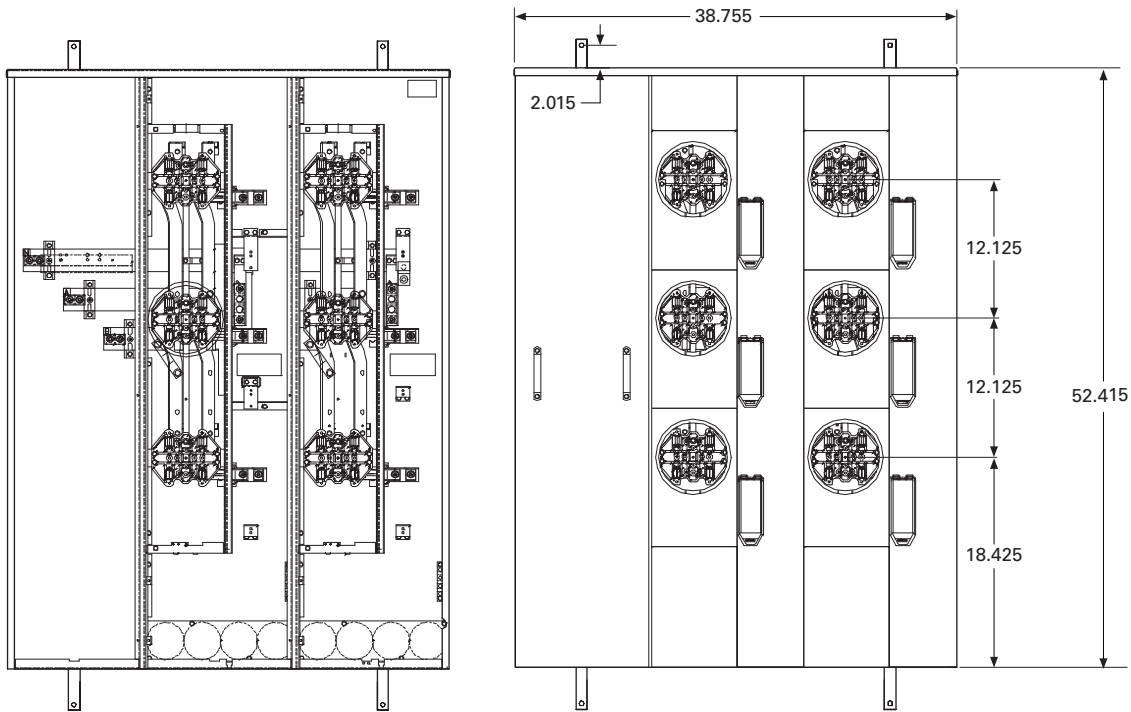

5 and 6 Meter Device

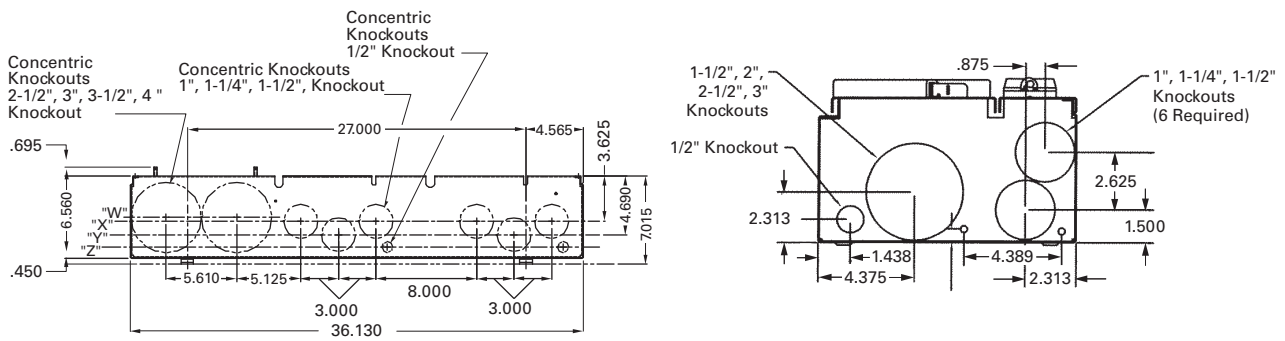

"Z" =  $\text{C}$  of 1/2" Ring  
 "Y" =  $\text{C}$  of 1-1/2" Ring  
 "X" =  $\text{C}$  of 1-1/2" Ring  
 "W" =  $\text{C}$  of 4" Ring

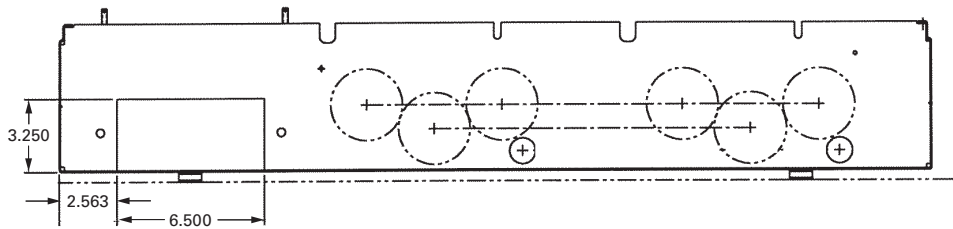

Bottom Endwall Knockouts for Units with "T" Suffix  
 5, 6 Meter Device

#### Main Tenant Circuit Breakers



#### Contents

<i>Description</i>	<i>Page</i>
Systems for Residential and Commercial Applications . . . . .	<b>V1-T4-68</b>
Meter Packs . . . . .	<b>V1-T4-76</b>
Meter Packs—Tenant Circuit Breakers . . . . .	<b>V1-T4-88</b>
Main Service Modules . . . . .	<b>V1-T4-89</b>
Residential Meter Stacks . . . . .	<b>V1-T4-108</b>
Commercial Meter Stack Modules . . . . .	<b>V1-T4-123</b>
35MM, 37MM, 35SS and 37SS Tenant Main Circuit Breakers . . . . .	<b>V1-T4-130</b>
Phase Balanced Stack . . . . .	<b>V1-T4-132</b>
Group Metering Inline Current Transformer Cabinets . . . . .	<b>V1-T4-133</b>
Surge Metering . . . . .	<b>V1-T4-134</b>
Group Metering Accessories . . . . .	<b>V1-T4-135</b>

### Meter Packs—1MP, 1MM and 3MM Main Tenant Circuit Breakers

#### Product Description

Specific main tenant circuit breakers that are to be used in meter packs (1MP), residential meter stacks (1MM) and three-phase in single-phase out meter stacks (3MM).

#### Product Selection

#### Meter Packs—1MP, 1MM and 3MM Main Tenant Circuit Breakers

Description	Number of Poles	Main Tenant Circuit Breaker Ampere Rating	10 kAIC Catalog Number ①	22 kAIC Catalog Number	25 kAIC Catalog Number ①②③④	42 kAIC Catalog Number ②③④	65 kAIC Catalog Number ②③④	100 kAIC Catalog Number ②③④
<b>Plug-On Type</b>								
Plug-on type circuit breakers used with 1MP, 1MM, and 3MM 125 A modular metering stacks	2	60	BR260	BRH260	—	BRHH260	BRX260	—
	2	70	BR270	BRH270	—	BRHH270	BRX270	—
	2	80	BR280	BRH280	—	BRHH280	BRX280	—
	2	90	BR290	BRH290	—	BRHH290	BRX290	—
	2	100	BR2100	BRH2100	—	BRHH2100	BRX2100	—
	2	110	BR2110	BRH2110	—	BRHH2110	BRX2110	—
	2	125	BR2125	BRH2125	—	BRHH2125	BRX2125	—
	<b>Bolt-On Type</b>							
Bolt-on type circuit breakers used with 1MP, 1MM, and 3MM 200 A modular metering stacks	2	60	CCV2060X	—	CCVH2060X	CVS2060XMM	CV2060XMM	CVH2060XMM
	2	70	CCV2070X	—	CCVH2070X	CVS2070XMM	CV2070XMM	CVH2070XMM
	2	80	CCV2080X	—	CCVH2080X	CVS2080XMM	CV2080XMM	CVH2080XMM
	2	90	CCV2090X	—	CCVH2090X	CVS2090XMM	CV2090XMM	CVH2090XMM
	2	100	CCV2100X	—	CCVH2100X	CVS2100XMM	CV2100XMM	CVH2100XMM
	2	125	CCV2125X	—	CCVH2125X	CVS2125XMM	CV2125XMM	CVH2125XMM
	2	150	CCV2150X	—	CCVH2150X	CVS2150XMM	CV2150XMM	CVH2150XMM
	2	175	CCV2175X	—	CCVH2175X	CVS2175XMM	CV2175XMM	CVH2175XMM
2	200	CCV2200X	—	CCVH2200X	CVS2200XMM	CV2200XMM	CVH2200XMM	

#### Notes

- ① #2–300 kcmil wire size range for CCV and CCVH tenant main circuit breakers.
- ② “MM” suffix indicates mounting hardware kit is included as standard with tenant main breaker.
- ③ 1MMCBK replacement mounting hardware kit. One kit is needed per breaker. Mounting hardware kit ships standard with breaker “MM” suffix offering.
- ④ #6–4/0 kcmil wire size range for CVS, CV and CVH tenant main circuit breakers. If #2–300 kcmil is needed, order 2TA225CVK. One kit needed per breaker.

Main Service Modules

Main Service Modules

Product Description

- Main terminal box
- Main circuit breaker
- Main bolted pressure switch
- Main fusible switch
- Main fusible switch with pull box
- Underground pull box

Application Description

Main Circuit Breakers with Busway Connections

The Service Entrance Product Team announces the availability of both main fusible switch and main circuit breaker group metering mains with busway connections. This offering provides us with the ability to offer multiple tenant metering in high rise apartment buildings where riser busway is used.

Features, Benefits and Functions

Eaton's Main Service Module

- Offering: main terminal/lug compartment, main circuit breaker, main fusible switch, main bolted pressure switch, main fusible switch with pull box (meets EUSERC electrical requirements), underground pull box termination compartment without cross bus (meets EUSERC electrical requirements)
- Mechanically and electrically built for use with 1MM, 3MM, 35MM, 37MM, 35SS and 37SS modular metering stacks
- For integrated system short-circuit ratings with main devices, see series ratings on **Page V1-T4-73**
- All main service modules include both left and right horizontal bus closure plates

Contents

<i>Description</i>	<i>Page</i>
Systems for Residential and Commercial Applications . . . . .	<b>V1-T4-68</b>
Meter Packs . . . . .	<b>V1-T4-76</b>
Meter Packs—Tenant Circuit Breakers . . . . .	<b>V1-T4-88</b>
Main Service Modules	
Catalog Number Selection . . . . .	<b>V1-T4-90</b>
Product Selection . . . . .	<b>V1-T4-91</b>
Dimensions . . . . .	<b>V1-T4-103</b>
Residential Meter Stacks . . . . .	<b>V1-T4-108</b>
Commercial Meter Stack Modules . . . . .	<b>V1-T4-123</b>
35MM, 37MM, 35SS and 37SS Tenant Main Circuit Breakers . . . . .	<b>V1-T4-130</b>
Phase Balanced Stack . . . . .	<b>V1-T4-132</b>
Group Metering Inline Current Transformer Cabinets . . . . .	<b>V1-T4-133</b>
Surge Metering . . . . .	<b>V1-T4-134</b>
Group Metering Accessories . . . . .	<b>V1-T4-135</b>

Main Circuit Breakers with Busway Connections

- Two-pole devices are applied to single-phase, three-wire, 120/240 V or 208Y/120 V systems, three-pole devices to 208Y/240 V or 120/240 V delta systems
  - Single-phase mains couple to any modular metering stack (1MM, 3MM, 35MM, 37MM, 35SS and 37SS)
  - Three-phase mains require three-phase bussed stacks. These modular metering stacks are 3MM, 35MM, 37MM, 35SS and 37SS
  - If the ampere rating of the main service module is greater than the horizontal bus rating of the meter stack (residential or commercial), the main service module must be center fed. Examples: 1200 A Main Circuit Breaker (**1MCB1200R**) with an 800 A residential stack (**1MM512R**). 1600 A Main Terminal Box (**3MTB1600R**) with a 1200 A residential stack (**3MM212R12**)
  - Most main service modules are available with aluminum or copper bus
- Three-phase, 400–200 A main circuit breakers
  - Three-phase, 400–800 A main fusible switches
  - Simple bridge joint connection
  - Variety of options:
    - Right or left mounting
    - Internal ground or housing ground
  - The MFS/MCB and busway connector are supplied completely assembled

# 4.3

## Metering Products

### Group Metering

#### Catalog Number Selection

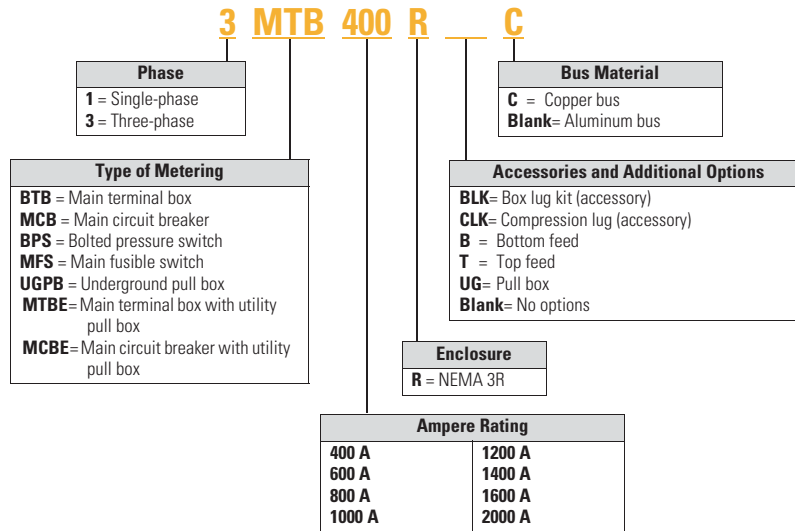

#### When Ordering:

1. Determine catalog number of Main Service Module.
2. Determine catalog number of Meter Stack (Residential or Commercial).
3. Find quantity and catalog numbers for tenant circuit breakers (found on **Page V1-T4-125** or **V1-T4-131**). Order one breaker per socket.
4. If any accessories are needed, order from **Pages V1-T4-136** and **V1-T4-137**.

**Product Selection**

**Main Terminal Box**

- Phase and neutral lugs are included
- Top or bottom feed:
  - For top feed, use Myer type hub
- Indoor or outdoor
- Terminal box UL listed short-circuit rating is the least AIC rating of any installed main tenant breaker—to a maximum of 100,000 rms symmetrical amperes

**Main Terminal Box**



**Main Terminal Box**

Ampere Rating	Line Side Lug and Wire Sizes—Included	System Voltage	
		120/240 Vac Single-Phase, Three-Wire Catalog Number	120/208 Vac Three-Phase, Four-Wire Catalog Number
<b>Aluminum Bus (Standard Offering)</b>			
400	(1) #6–600 or (2) 1/0–250 kcmil ②	Use three-phase	<b>3MTB400R</b>
600	(2) 250–500 kcmil ③	Use three-phase	<b>3MTB600R</b>
800	(4) 250–500 kcmil ④⑤	<b>1MTB800R</b>	<b>3MTB800R</b>
1200 ①	(4) 250–500 kcmil ⑥⑥	<b>1MTB1200R</b>	<b>3MTB1200R</b>
<b>Aluminum Bus (EUSERC)</b>			
400	Crimp lug landing pads (no lugs included)	<b>1MTBE400R</b> ⑦	<b>3MTBE400R</b> ⑦
800	Crimp lug landing pads (no lugs included)	<b>1MTBE800R</b> ⑦	<b>3MTBE800R</b> ⑦
<b>Copper Bus (Premium Offering)</b>			
400	(1) #6–600 or (2) 1/0–250 kcmil ②	Use three-phase	<b>3MTB400RC</b>
600	(2) 250–500 kcmil ③	Use three-phase	<b>3MTB600RC</b>
800	(4) 250–500 kcmil ④⑤	<b>1MTB800RC</b>	<b>3MTB800RC</b>
1200 ①	(4) 250–500 kcmil ⑥⑥	<b>1MTB1200RC</b>	<b>3MTB1200RC</b>
1400	(6) #2–600 kcmil	<b>1MCB1400RBC-600</b>	<b>3MCB1400RBC-600</b>
1400	(6) #2–600 kcmil	<b>1MCB1400RT-600</b>	<b>3MCB1400RT-600</b>
1600 ①	(6) 250–500 kcmil	<b>1MTB1600RC</b>	<b>3MTB1600RC</b>
2000 ①	(8) 1/0–750 kcmil or (16) 1/0–300 kcmil	<b>1MTB2000RC</b>	<b>3MTB2000RC</b>

**Main Terminal Box Riser Panel**

Eaton’s Main Terminal Box Riser Panel is a main terminal box with offset lugs on each

phase to allow riser cables to pass through the main service module.

These panels are used in the construction of assisted living homes, dormitories, public housing complexes and apartments.

**Main Terminal Box Riser Panel**

Ampere Rating	Line and Load Side Lug and Wire Sizes Included	System Voltage	
		120/240 Vac Single-Phase, Three-Wire Catalog Number	120/208 Vac Three-Phase, Four-Wire Catalog Number
<b>Copper Bus (Standard Offering)</b>			
1200	#2–750 kcmil ①⑥	Use three-phase	<b>3MTB1200RCRIS</b>
1600	#2–750 kcmil ①⑥	Use three-phase	<b>3MTB1600RCRIS</b>
2000	#2–750 kcmil ①⑥	<b>1MTB2000RCRIS</b>	<b>3MTB2000RCRIS</b>

**Notes**

- ① 1200 A main devices must be center fed when installing 800 A residential meter stacks. 1600 A and 2000 A main devices must be center fed when installing 800–1200 A residential and commercial meter stacks.
- ② For 400 A units, to obtain (4) 750 kcmil cables per phase—order quantity 4 **1MPLK2**. Kit contains one lug.
- ③ For compression lug landing kits for 600 A units, order **3MTB600CLK**. Kit includes lug landings for three phases and neutral.
- ④ For 800 A units, to obtain (4) 1/0–300 kcmil or (2) 1/0–750 kcmil cables per phase—order catalog number **3MTB800BLK**, one lug kit per main terminal box ordered (neutral and ground included in kit).
- ⑤ For 800 A and 1200 A units, for compression lug landing kits, order **3MTB1200CLK**. Kit includes lug landings for three-phase and neutral.
- ⑥ For 1200 A units, to obtain (6) 1/0–300 kcmil or (3) 750 kcmil cables per phase—order catalog number **3MTB1200BLK**, one lug kit per main terminal box ordered (neutral and ground included in kit).
- ⑦ Meets EUSERC electrical requirements and eliminates the need to add additional pull box section. Reference drawing EUSERC DWG-343.
- ⑧ Quantity (10) lugs per phase—quantity (5) lugs incoming and quantity (5) lugs outgoing per phase.
- ⑨ Quantity (16) lugs per phase—quantity (8) lugs incoming and quantity (8) lugs outgoing per phase.



#### Aluminum Bus—Standard Offering

##### Main Circuit Breaker

- Phase and neutral lugs included. If additional neutral lugs are needed, order 1MCB1200NLK for (3) 1/0–750 or (6) 1/0–300 kcmil
- For shunt trip mains, order the field-installable shunt trip kit in this volume, Tab 1, section 1.1
- For overhead feed, use Myer type hub. Verify local utility approval
- For compression lugs on 400, 600, 800, 1000 and 1200 A units, add CL to the end of the part number (includes copper lug pads for lines and neutral)
- 1200 A or greater main devices must be center fed when installing 800 A residential meter stacks
- 1400, 1600 and 2000 A main devices must be center fed when installing 800 and 1200 A residential and commercial meter stacks

Main Circuit Breaker



#### Main Circuit Breaker

Main Ampere Rating	Main Circuit Breaker Type	Feed	kAIC	Line Side Lug and Wire Sizes (Lugs Included with Main Breaker) ①	System Voltage	
					120/240 Vac Single-Phase, Three-Wire Catalog Number	120/208 Vac Three-Phase, Four-Wire Catalog Number
<b>Aluminum Bus (Standard Offering)</b>						
250	KD	Bottom/top	65	(2) 3/0–250 kcmil or (1) 2/0–500 kcmil	<b>1MCB250R</b>	<b>3MCB250R</b>
250	HKD	Bottom/top	100	(2) 3/0–250 kcmil or (1) 2/0–500 kcmil	<b>1MHCB250R</b>	<b>3MHCB250R</b>
300	KD	Bottom/top	65	(2) 3/0–250 kcmil or (1) 2/0–500 kcmil	<b>1MCB300R</b>	<b>3MCB300R</b>
300	HKD	Bottom/top	100	(2) 3/0–250 kcmil or (1) 2/0–500 kcmil	<b>1MHCB300R</b>	<b>3MHCB300R</b>
350	KD	Bottom/top	65	(2) 3/0–250 kcmil or (1) 2/0–500 kcmil	<b>1MCB350R</b>	<b>3MCB350R</b>
350	HKD	Bottom/top	100	(2) 3/0–250 kcmil or (1) 2/0–500 kcmil	<b>1MHCB350R</b>	<b>3MHCB350R</b>
400	KD	Bottom/top	65	(2) 3/0–250 kcmil or (1) 2/0–500 kcmil	<b>1MCB400R</b> ②	<b>3MCB400R</b> ②
400	HKD	Bottom/top	100	(2) 3/0–250 kcmil or (1) 2/0–500 kcmil	<b>1MHCB400R</b> ②	<b>3MHCB400R</b> ②
500	LD	Bottom/top	65	(2) 400–500 kcmil	<b>1MCB500R</b>	<b>3MCB500R</b>
500	HLD	Bottom/top	100	(2) 400–500 kcmil	<b>1MHCB500R</b>	<b>3MHCB500R</b>
600	LD	Bottom/top	65	(2) 400–500 kcmil	<b>1MCB600R</b> ②	<b>3MCB600R</b> ②
600	HLD	Bottom/top	100	(2) 400–500 kcmil	<b>1MHCB600R</b> ②	<b>3MHCB600R</b> ②
700	HMDL	Bottom/top	100	(3) 3/0–400 kcmil	<b>1MHCB700R</b>	<b>3MHCB700R</b>
700	MDL	Bottom/top	65	(3) 3/0–400 kcmil	<b>1MCB700R</b>	<b>3MCB700R</b>
800	MDL	Bottom/top	65	(3) 3/0–400 kcmil	<b>1MCB800R</b> ②	<b>3MCB800R</b> ②
800	MDL	Bottom/top	65	(2) 500–750 kcmil	<b>1MCB800R750</b>	<b>3MCB800R750</b>
800	HMDL	Bottom/top	100	(3) 3/0–400 kcmil	<b>1MHCB800R</b> ②	<b>3MHCB800R</b> ②
900	NGS	Bottom/top	65	(4) 4/0–500 kcmil ③	<b>1MCB900R</b> ④	<b>3MCB900R</b> ④
900	NGH	Bottom/top	100	(4) 4/0–500 kcmil ③	<b>1MHCB900R</b> ④	<b>3MHCB900R</b> ④
1000	NGS	Bottom/top	65	(4) 4/0–500 kcmil ③	<b>1MCB1000R</b> ②④	<b>3MCB1000R</b> ②④
1000	NGS	Bottom/top	65	(3) 500–750 kcmil	<b>1MCB1000R750</b>	<b>3MCB1000R750</b>
1000	NGH	Bottom/top	100	(4) 4/0–500 kcmil ③	<b>1MHCB1000R</b> ②④	<b>3MHCB1000R</b> ②④
1200	NGS	Bottom/top	65	(4) 4/0–500 kcmil ③	<b>1MCB1200R</b> ②④	<b>3MCB1200R</b> ②④
1200	NGH	Bottom/top	100	(4) 4/0–500 kcmil ③	<b>1MHCB1200R</b> ②④	<b>3MHCB1200R</b> ②④
1200	NGS	Bottom/top	65	(3) 500–750 kcmil	Use three-phase	<b>3MCB1200R750</b>

**Notes**

- ① If additional neutral lugs are needed, order **1MCB1200NLK** [(3) 1/0–750 kcmil or (6) 1/0–300 kcmil].
- ② Add CL to end of catalog number for compression lug pads (includes lug pads for lines and neutral).
- ③ If (3) 500–750 kcmil are needed, order **TA1201NB1**. Order one kit per pole.
- ④ Main devices with a rating greater than 800 A can be used with 800 A residential modular stacks, but only as a center fed main.

Copper Bus—Premium Offering

Main Circuit Breaker

Main Circuit Breaker



Main Ampere Rating	Main Circuit Breaker Type	Feed	kAIC	Line Side Lug and Wire Sizes (Lugs Included with Main Breaker) ①	System Voltage 120/240 Vac Single-Phase, Three-Wire Catalog Number	120/208 Vac Three-Phase, Four-Wire Catalog Number
<b>Copper Bus (Premium Offering)</b>						
400	KD	Bottom/top	65	(2) 3/0–250 kcmil or (1) 2/0-500 kcmil	<b>1MCB400RC</b> ②	<b>3MCB400RC</b> ②
400	HKD	Bottom/top	100	2/0–500 kcmil	<b>1MHCB400RC</b> ②	<b>3MHCB400RC</b> ②
600	LD	Bottom/top	65	(2) 300–500 kcmil	<b>1MCB600RC</b> ②	<b>3MCB600RC</b> ②
600	HLD	Bottom/top	100	(2) 300–500 kcmil	<b>1MHCB600RC</b> ②	<b>3MHCB600RC</b> ②
800	MDL	Bottom/top	65	(3) 3/0–400 kcmil	<b>1MCB800RC</b> ②	<b>3MCB800RC</b> ②
800	HMDL	Bottom/top	100	(3) 3/0–400 kcmil	<b>1MHCB800RC</b> ②	<b>3MHCB800RC</b> ②
900	NGS	Bottom/top	65	(4) 4/0–500 kcmil ③	<b>1MCB900RC</b> ④	<b>3MCB900RC</b> ④
900	NGH	Bottom/top	100	(4) 4/0–500 kcmil ③	<b>1MHCB900RC</b> ④	<b>3MHCB900RC</b> ④
1000	NGS	Bottom/top	65	(3) 500–750 kcmil	<b>1MCB1000R750C</b>	<b>3MCB1000R750C</b>
1000	NGS	Bottom/top	65	(4) 4/0–500 kcmil ③	<b>1MCB1000RC</b> ②④	<b>3MCB1000RC</b> ②④
1000	NGH	Bottom/top	100	(4) 4/0–500 kcmil ③	<b>1MHCB1000RC</b> ②④	<b>3MHCB1000RC</b> ②④
1200	NGS	Bottom	65	(3) 500–750 kcmil	Use three-phase	<b>3MCB1200R750C</b>
1200	NGS	Bottom	65	(4) 4/0–500 kcmil ③	<b>1MCB1200RC</b> ②④	<b>3MCB1200RC</b> ②④
1200	NGH	Bottom	100	(4) 4/0–500 kcmil ③	<b>1MHCB1200RC</b> ②④	<b>3MHCB1200RC</b> ②④
1400	RGH	Bottom	100	(4) 500–1000 kcmil ⑤	<b>1MCB1400RBC</b> ④	<b>3MCB1400RBC</b> ④
1400	RGH	Top	100	(4) 500–1000 kcmil ⑤	<b>1MCB1400RT</b> ⑥	<b>3MCB1400RT</b> ⑥
1400	RGH	Bottom	100	(6) #2–600 kcmil	<b>1MCB1400RBC-600</b> ④	<b>3MCB1400RBC-600</b> ④
1400	RGH	Top	100	(6) #2–600 kcmil	<b>1MCB1400RT-600</b> ④	<b>3MCB1400RT-600</b> ④
1600	RGH	Bottom	100	(4) 500–1000 kcmil ⑤	<b>1MCB1600RBC</b> ⑦	<b>3MCB1600RBC</b> ⑦
1600	RGH	Top	100	(4) 500–1000 kcmil ⑤	<b>1MCB1600RT</b> ⑦	<b>3MCB1600RT</b> ⑦
1600	RGH	Bottom	100	(6) #2–600 kcmil	<b>1MCB1600RBC-600</b> ④	<b>3MCB1600RBC-600</b> ④
1600	RGH	Top	100	(6) #2–600 kcmil	<b>1MCB1600RT-600</b> ④	<b>3MCB1600RT-600</b> ④
2000	RGH	Bottom	100	(6) #2–600 kcmil	<b>1MCB2000RBC</b> ⑦	<b>3MCB2000RBC</b> ⑦
2000	RGH	Top	100	(6) #2–600 kcmil	<b>1MCB2000RT</b> ⑦	<b>3MCB2000RT</b> ⑦

Notes

- ① If additional neutral lugs are needed, order **1MCB1200NLK** [(3) 1/0–750 kcmil or (6) 1/0–300 kcmil].
- ② Add CL to end of catalog number for compression lug pads (includes lug pads for lines and neutral).
- ③ If (3) 500–750 kcmil are needed, order **TA1201NB1**. Order one kit per pole.
- ④ Main devices with a rating greater than 800 A can be used with 800 A residential modular stacks but only as a center fed main.
- ⑤ If (6) #2–600 kcmil lugs are needed, order **TA2000RD**. Catalog number includes terminals and hardware for three poles. If neutral is needed, order **TA2000N**.
- ⑥ Main devices with a rating greater than 1200 A can be used with residential and commercial modular metering stacks but only as a center fed main.
- ⑦ Only to be used in center feed applications with 1200 A meter stacks. Not to be used with 800 A stacks.

#### Aluminum Bus—EUSERC

Main Circuit Breaker

#### Main Circuit Breaker, EUSERC



4

Main Ampere Rating	Main Circuit Breaker Type	Feed	KAIC	Line Side Lug and Wire Sizes (Lugs Included with Main Breaker) ①	System Voltage	
					120/240 Vac Single-Phase, Three-Wire Catalog Number	120/208 Vac Three-Phase, Four-Wire Catalog Number
<b>Aluminum Bus (EUSERC) ②</b>						
300	KD	Bottom	65	Crimp lug landing pads (no lugs included)	<b>1MCBE300R</b>	<b>3MCBE300R</b>
350	KD	Bottom	65	Crimp lug landing pads (no lugs included)	<b>1MCBE350R</b>	<b>3MCBE350R</b>
400	KD	Bottom	65	Crimp lug landing pads (no lugs included)	<b>1MCBE400R</b>	<b>3MCBE400R</b>
400	HKD	Bottom	100	Crimp lug landing pads (no lugs included)	<b>1MHCBE400R</b>	<b>3MHCBE400R</b>
500	LD	Bottom	65	Crimp lug landing pads (no lugs included)	<b>1MCBE500R</b>	<b>3MCBE500R</b>
600	LD	Bottom	65	Crimp lug landing pads (no lugs included)	<b>1MCBE600R</b>	<b>3MCBE600R</b>
600	HLD	Bottom	100	Crimp lug landing pads (no lugs included)	<b>1MHCBE600R</b>	<b>3MHCBE600R</b>
800	MDL	Bottom	65	Crimp lug landing pads (no lugs included)	<b>1MCBE800R</b>	<b>3MCBE800R</b>
800	HMDL	Bottom	100	Crimp lug landing pads (no lugs included)	<b>1MHCBE800R</b>	<b>3MHCBE800R</b>
1000	NGS	Bottom	65	Crimp lug landing pads (no lugs included)	<b>1MCBE1000R</b>	<b>3MCBE1000R</b>
1200	NGS	Bottom	65	Crimp lug landing pads (no lugs included)	<b>1MCBE1200R</b>	<b>3MCBE1200R</b>
1200	NGH	Bottom	100	Crimp lug landing pads (no lugs included)	<b>1MHCBE1200R</b>	<b>3MHCBE1200R</b>

#### Copper Bus—EUSERC

Main Circuit Breaker

#### Main Circuit Breaker



Main Ampere Rating	Main Circuit Breaker Type	Feed	KAIC	Line Side Lug and Wire Sizes (Lugs Included with Main Breaker) ①	System Voltage	
					120/240 Vac Single-Phase, Three-Wire Catalog Number	120/208 Vac Three-Phase, Four-Wire Catalog Number
<b>Copper Bus (EUSERC) ②</b>						
1000	NGS	Bottom	65	Crimp lug landing pads (no lugs included)	<b>1MCBE1000RC</b>	<b>3MCBE1000RC</b>
1200	NGS	Bottom	65	Crimp lug landing pads (no lugs included)	<b>1MCBE1200RC</b>	<b>3MCBE1200RC</b>
1200	NGH	Bottom	100	Crimp lug landing pads (no lugs included)	<b>1MHCBE1200RC</b>	<b>3MHCBE1200RC</b>

**Notes**

- ① If additional neutral lugs are needed, order **1MCB1200NLK** [(3) 1/0–750 kcmil or (6) 1/0–300 kcmil].
- ② Main devices with a rating greater than 1200 A can be used with residential and commercial modular metering stacks but only as a center fed main.

**Arcflash Reduction Maintenance System™ for group metering mains**

Eaton’s Arcflash Reduction Maintenance System (ARMS) for group metering main breakers enhances worker safety in multi-tenant residential and light commercial applications by reducing the arc flash potential while performing maintenance. With a reduction in arc flash hazard risk, workers can operate with improved mobility without sacrificing safety. ARMS provides accelerated instantaneous trip, reducing potential arc flash. 310+ trip unit provides the fastest clearing times in the industry, with less arc energy.

**Services**

Eaton can offer a higher degree of application knowledge and technical support, along with reduced complexity. To further support utility teams, Eaton offers comprehensive, tailored training, offered both virtually and onsite.

**Training**

- Intro to Eaton  
Learn more about our company and our history of innovation
- Meter Products Overview  
Comprehensive overview of Eaton’s metering product line, available configurations and features
- Technical Metering  
A deeper dive into complex metering issues, such as phase balancing or the Arcflash Reduction Maintenance System
- Codes and Standards  
Discussion of increasingly complex federal and state regulations to decrease burdens on utility staff, and reduce operations at risk

**Support**

With a strong presence and local sales offices throughout the U.S., Eaton’s national footprint and extensive utility presence allows us to connect with your business—wherever it operates—offering local engineering, project management and service providers for immediate support to improve uptime, increase safety and reduce costs. Eaton’s team includes utility application-specific experts with a track record of solving unique problems and managing complex, integrated solutions and turnkey projects.

Main Circuit Breaker



**Main Circuit Breaker with Arcflash Reduction Maintenance Switch**

Main Ampere Rating	Main Circuit Breaker Type	Feed	kAIC	Line Side Lug and Wire Sizes (Lugs Included with Main Breaker)	System Voltage 120/240 Vac	System Voltage 120/208 Vac
					Single-Phase, Three-Wire	Three-Phase, Four-Wire
					Catalog Number	Catalog Number
<b>Aluminum Bus (Standard Offering)</b>						
900	NGS	Top	65	(4) 4/0–500 kcmil	1MCB900RA	3MCB900RA
1000	NGS	Bottom/top	65	(4) 4/0–500 kcmil	1MCB1000RA	3MCB1000RA
1000	NGS	Bottom/top	65	(3) 500–750 kcmil	1MCB1000RA750	3MCB1000RA750
1000	NGS	Bottom	65	Crimp lug landing pads (no lugs included)	1MCBE1000RA	3MCBE1000RA
1000	NGH	Bottom/top	100	(4) 4/0–500 kcmil	1MHCB1000RA	3MHCB1000RA
1200	NGS	Bottom/top	65	(4) 4/0–500 kcmil	1MCB1200RA	3MCB1200RA
1200	NGS	Bottom	65	Crimp lug landing pads (no lugs included)	1MCBE1200RA	3MCBE1200RA
1200	NGH	Bottom/top	100	(4) 4/0–500 kcmil	1MHCB1200RA	3MHCB1200RA
1200	NGH	Bottom	100	Crimp lug landing pads (no lugs included)	1MHCE1200RA	3MHCE1200RA
1400	RGH	Top	100	(4) #500–1000 kcmil	1MCB1400RTA	3MCB1400RTA
1600	RGH	Top	100	(6) #2–600 kcmil	1MCB1600RTA600	3MCB1600RTA600
1600	RGH	Top	100	(4) #500–1000 kcmil	—	3MCB1600RTA
2000	RGH	Top	100	(6) #2–600 kcmil	1MCB2000RTA	3MCB2000RTA

#### Main Circuit Breaker with Arcflash Reduction Maintenance Switch

Main Ampere Rating	Main Circuit Breaker Type	Feed	kAIC	Line Side Lug and Wire Sizes (Lugs Included with Main Breaker) ①	System Voltage 120/240 Vac	System Voltage 120/208 Vac
					Single-Phase, Three-Wire	Three-Phase, Four-Wire
					Catalog Number	Catalog Number
<b>Copper Bus (Premium Offering) ②</b>						
1000	NGS	Bottom/top	65	(4) 4/0–500 kcmil	<b>1MCB1000RCA</b>	<b>3MCB1000RCA</b>
1000	NGS	Bottom	65	Compression lug pads	<b>1MCB1000RCCLA</b>	<b>3MCB1000RCCLA</b>
1000	NGH	Bottom	100	Compression lug pads	<b>1MHCB1000RCCLA</b>	<b>3MHCB1000RCCLA</b>
1000	NGH	Bottom/top	100	(4) 4/0–500 kcmil	—	<b>3MCBE1000RCA</b>
1000	NGH	Bottom	100	(4) 4/0–500 kcmil	—	<b>3MHCB1000RCA</b>
1200	NGS	Bottom/top	65	(2) 500–750 kcmil	<b>1MCB1200RCA</b>	<b>3MCB1200RCA</b>
1200	NGS	Bottom	65	Compression lug pads	<b>1MCB1200RCCLA</b>	<b>3MCB1200RCCLA</b>
1200	NGS	Bottom/top	65	(3) 500–750 kcmil	—	<b>3MCB1200RA750C</b>
1200	NGH	Bottom/top	100	(4) 4/0–500 kcmil	<b>1MHCB1200RCA</b>	<b>3MHCB1200RCA</b>
1200	NGH	Bottom	100	Compression lug pads	—	<b>3MHCB1200RCCLA</b>
1400	RGH	Bottom/top	100	(4) #500–1000 kcmil	<b>1MCB1400RBCA</b>	<b>3MCB1400RBCA</b>
1400	RGH	Bottom/top	100	(6) #2–600 kcmil	<b>1MCB1400RBCA600</b>	<b>3MCB1400RBCA600</b>
1400	RGH	Bottom	100	Compression lug pads	<b>1MCB1400RUGCCLA</b>	<b>3MCB1400RUGCCLA</b>
1600	RGH	Bottom/top	100	(4) #500–1000 kcmil	<b>1MCB1600RBCA</b>	<b>3MCB1600RBCA</b>
1600	RGH	Bottom/top	100	(6) #2–600 kcmil	<b>1MCB1600RBCA600</b>	<b>3MCB1600RBCA600</b>
1600	RGH	Bottom	100	Compression lug pads	<b>1MCB1600RUGCCLA</b>	<b>3MCB1600RUGCCLA</b>
2000	RGH	Bottom/top	100	(6) #2–600 kcmil	<b>1MCB2000RBCA</b>	<b>3MCB2000RBCA</b>
2000	RGH	Bottom	100	Compression lug pads	<b>1MCB2000RUGCCLA</b>	<b>3MCB2000RUGCCLA</b>

**Main Circuit Breaker with Utility Pull Box**

- These main circuit breakers are not suitable for EUSERC territories

**Main Circuit Breaker with Utility Pull Box**

Ampere Rating	Main Circuit Breaker Type	Feed	kAIC	Line Side Lug and Wire Sizes	System Voltage	
					120/240 Vac, Single-Phase, Three-Wire	120/208 Vac, Three-Phase, Four-Wire
<b>Aluminum Bus (Standard Offering)</b>						
1400	RGH	Bottom/Top	65	Crimp lug landing pads (lugs not included)	<b>1MCB1400RUGCCL</b>	<b>3MCB1400RUGCCL</b>
1600	RGH	Bottom/Top	65	Crimp lug landing pads (lugs not included)	<b>1MCB1600RUGCCL</b>	<b>3MCB1600RUGCCL</b>
2000	RGH	Bottom/Top	65	Crimp lug landing pads (lugs not included)	<b>1MCB2000RUGCCL</b>	<b>3MCB2000RUGCCL</b>
<b>Copper Bus (Premium)</b>						
1600	RGH	Bottom/Top	100	Crimp lug landing pads (lugs not included)	<b>1MHCB1600RUGCCL</b>	<b>3MHCB1600RUGCCL</b>
2000	RGH	Bottom/Top	100	Crimp lug landing pads (lugs not included)	<b>1MHCB2000RUGCCL</b>	<b>3MHCB2000RUGCCL</b>

**Main Fusible Switch with Utility Pull Box**

- Fuses not included
- Includes lug landing pads on line side and neutral
- Complies with EUSERC requirements as long as spacer kit 3MMBSK is used
- 100 kAIC rating on switches with Class T fuse clips installed

**Main Fusible Switch with Utility Pull Box ①**

**Main Fusible Switch with Utility Pull Box**



Ampere Rating	Feed	Class Fuse Clips (Fuses Not Included)	Line Side Box Lugs and Wire Sizes (Included with Switch)	System Voltage	
				120/240 Vac Single-Phase, Three-Wire Catalog Number	120/208 Vac Three-Phase, Four-Wire Catalog Number
<b>Aluminum Bus (Standard Offering)</b>					
400	Bottom	T	②	<b>1MFS400RUG</b>	<b>3MFS400RUG</b>
600	Bottom	T	②	<b>1MFS600RUG</b>	<b>3MFS600RUG</b>
800	Bottom	T, L	②	<b>1MFS800RUG</b>	<b>3MFS800RUG</b>
1200	Bottom	T	②	<b>1MFS1200RUG</b>	<b>3MFS1200RUG</b>
<b>Copper Bus (Premium Offering)</b>					
400	Bottom	T	②	<b>1MFS400RUGC</b>	<b>3MFS400RUGC</b>
600	Bottom	T	②	<b>1MFS600RUGC</b>	<b>3MFS600RUGC</b>
800	Bottom	T, L	②	<b>1MFS800RUGC</b>	<b>3MFS800RUGC</b>
1200	Bottom	T	②	<b>1MFS1200RUGC</b>	<b>3MFS1200RUGC</b>

**Notes**

- ① Reference drawing EUSERC DWG-315.
- ② Pull box section includes landing studs for line side compression lugs. Wire sizes refer to load side connection.
- ③ Reference drawing EUSERC DWG-343.

#### Main Fusible Switches

- Fuses not included
- Main lugs and neutral included with device
- 100 kAIC rating on switches with Class T fuses installed. If converting to Class H, the kAIC rating is 10 and if converted to Class R, the kAIC rating is 200
- 800 A top and bottom fed units are supplied with Class T fuse clips as standard. The Class T fuse clips are field convertible to Class L by repositioning. No kit is needed
- Barrier kits available for 400–800 A fusible switches:  
Bottom feed—**3MFSBBK**,  
Top feed—**3MFSBTK**

**Note:** This is the fuse rating, switch still rated at 100 kAIC.

#### Main Fusible Switches

#### Main Fusible Switches



Ampere Rating	Feed	Class Fuse Clips (Fuses Not Included)	Line Side Box Lugs and Wire Sizes (Included with Switch)	System Voltage 120/240 Vac Single-Phase, Three-Wire Catalog Number	120/208 Vac Three-Phase, Four-Wire Catalog Number
<b>Aluminum Bus (Standard Offering)</b>					
400	Bottom	T ①	(2) 1/0–300 kcmil or (1) 750 kcmil ④⑤	<b>1MFS400RB</b>	<b>3MFS400RB</b>
400	Top	T ①	(2) 1/0–300 kcmil or (1) 750 kcmil ④⑥	<b>1MFS400RT</b>	<b>3MFS400RT</b>
600	Bottom	T ②	(2) #2–600 kcmil ④⑤	<b>1MFS600RB</b>	<b>3MFS600RB</b>
600	Top	T ②	(2) #2–600 kcmil ④⑥	<b>1MFS600RT</b>	<b>3MFS600RT</b>
800	Bottom	T, L ③	(4) 3/0–750 kcmil ④	<b>1MFS800RB</b>	<b>3MFS800RB</b>
800	Top	T, L ③	(4) 3/0–750 kcmil ④	<b>1MFS800RT</b>	<b>3MFS800RT</b>
1200	Bottom	T, L ③	(4) #2–600 kcmil ⑦	<b>1MFS1200RB</b>	<b>3MFS1200RB</b>
<b>Copper Bus (Premium Offering)</b>					
400	Bottom	T ①	(2) 1/0–300 kcmil or (1) 750 kcmil ④⑤	<b>1MFS400RBC</b>	<b>3MFS400RBC</b>
400	Top	T ①	(2) 1/0–300 kcmil or (1) 750 kcmil ④⑥	<b>1MFS400RTC</b>	<b>3MFS400RTC</b>
600	Bottom	T ②	(2) #2–600 kcmil ④⑤	<b>1MFS600RBC</b>	<b>3MFS600RBC</b>
600	Top	T ②	(2) #2–600 kcmil ④⑥	<b>1MFS600RTC</b>	<b>3MFS600RTC</b>
800	Bottom	T, L ③	(4) 3/0–750 kcmil ④	<b>1MFS800RBC</b>	<b>3MFS800RBC</b>
800	Top	T, L ③	(4) 3/0–750 kcmil ④	<b>1MFS800RTC</b>	<b>3MFS800RTC</b>
1200	Bottom	T, L ③	(4) #2–600 kcmil ⑦	<b>1MFS1200RBC</b>	<b>3MFS1200RBC</b>

#### Notes

- ① If Class H fuse clips are needed, use catalog number **WCG3HK400** (order 1) per phase.  
If Class R fuse clips are needed, order catalog number **DS56FK** in addition to **WCG3HK400**.  
In order to go from T to R, the device must first be converted to H.  
All kits are field installable and each **DS56FK** kit will convert three poles.
- ② If Class H fuse clips are needed, use catalog number **WCG3HK600** (order 1) per phase.  
If Class R fuse clips are needed, order catalog number **DS66FK** in addition to **WCG3HK600**.  
In order to go from T to R, the device must first be converted to H.  
All kits are field installable and each **DS66FK** kit will convert three poles.
- ③ Class T fuse clips provided are field convertible to Class L by repositioning. No kit is needed.
- ④ If compression lugs are being used, order **3MFS800CLK**. This compression lug kit includes four pads (three poles and neutral).
- ⑤ 1MFS600BLK (4) 3/0–750 kcmil/phase (one kit/phase and one kit/neutral).
- ⑥ If compression lugs are being used, order **3MFS800CLKT**. This compression lug kit includes four pads (three poles and neutral).
- ⑦ IMFS1200LK (3) 750 kcmil/phase (one kit/phase). IMFS1200LKN (3) 750 kcmil (neutral).

**Utility Pull Box**

- Includes lug landing pads on line side and neutral
- Requires cable connection in field to main device; does not include horizontal cross bus

**Utility Pull Box** ①

Ampere Rating	Feed	Line Side Lug Information	Load Side Lug Information for Cable Connection to Main Disconnect	System Voltage	
				120/240 Vac Single-Phase, Three-Wire Catalog Number	120/208 Vac Three-Phase, Four-Wire Catalog Number
<b>Aluminum Bus (Standard Offering)</b>					
400	Bottom	Crimp lug landing pads (no lugs included)	1/0–750 kcmil or (2) 1/0–300 kcmil	<b>1UGPB400R</b>	<b>3UGPB400R</b>
800	Bottom	Crimp lug landing pads (no lugs included)	(2) 1/0–750 kcmil or (4) 1/0–300 kcmil	<b>1UGPB800R</b>	<b>3UGPB800R</b>
1200	Bottom	Crimp lug landing pads (no lugs included)	(4) #2–600 kcmil	<b>1UGPB1200R</b>	<b>3UGPB1200R</b>
<b>Copper Bus (Premium Offering)</b>					
400	Bottom	Crimp lug landing pads (no lugs included)	1/0–750 kcmil or (2) 1/0–300 kcmil	<b>1UGPB400RC</b>	<b>3UGPB400RC</b>
800	Bottom	Crimp lug landing pads (no lugs included)	(2) 1/0–750 kcmil or (4) 1/0–300 kcmil	<b>1UGPB800RC</b>	<b>3UGPB800RC</b>
1200	Bottom	Crimp lug landing pads (no lugs included)	(4) #2–600 kcmil	<b>1UGPB1200RC</b>	<b>3UGPB1200RC</b>

**Main Bolted Pressure Contact Switches**

- Add suffix ST to catalog number for shunt trip
- Fuses not included
- 100 kAIC rating on switches with Class L fuses installed

**Main Bolted Pressure Contact Switches**

Rating	Feed	Class Fuse Clips	Single-Phase, Three-Wire Catalog Number	Three-Phase, Four-Wire Catalog Number	Line Side Lugs and Wire Sizes Minimum or Maximum Wire Size ②
<b>Copper Bus</b>					
1200	Bottom	L	<b>1BPS1200RB</b>	<b>3BPS1200RB</b>	(4) 1/0–750 kcmil or (8) 1/0–300 kcmil
1200	Top	L	<b>1BPS1200RT</b>	<b>3BPS1200RT</b>	(4) 1/0–750 kcmil or (8) 1/0–300 kcmil
1600	Bottom	L	Use three-phase	<b>3BPS1600RB</b>	(6) 1/0–750 kcmil or (12) 1/0–300 kcmil
1600	Top	L	Use three-phase	<b>3BPS1600RT</b>	(6) 1/0–750 kcmil or (12) 1/0–300 kcmil
2000	Bottom	L	Use three-phase	<b>3BPS2000RB</b>	(8) 1/0–750 kcmil or (16) 1/0–300 kcmil
2000	Top	L	Use three-phase	<b>3BPS2000RT</b>	(8) 1/0–750 kcmil or (16) 1/0–300 kcmil
Ground lug			—	—	(5) #6–250 kcmil

**Notes**

- ① Pull box section includes landing studs for line side compression lugs. Wire sizes refer to load side connection.
- ② Lugs included.



# 4.3

## Metering Products

### Group Metering

#### Main Fusible Switch with Busway Connection

Verify proper left/right–bus/main phasing.

**Note:** “Right” means that the bus duct is to the right of the main and “left” means that the bus duct is to the left of the main. (See Dimension/Layout section for clarification.)

Using this information, select the correct main device catalog number per the selection chart.

#### 4 Main Fusible Switch with Busway Connection (3MFS...)

Ampere Rating	Internal Ground or Housing Ground	Standard T or TO Opposite Phasing	Right or Left Side	System Voltage 120/208 Vac Three-Phase, Four-Wire Catalog Number
400	Internal	TO	Right	<b>3MFS400BCRGTO</b>
600	Internal	TO	Right	<b>3MFS600BCRGTO</b>
800	Internal	TO	Right	<b>3MFS800BCRGTO</b>
400	Internal	TO	Left	<b>3MFS400BCLGTO</b>
600	Internal	TO	Left	<b>3MFS600BCLGTO</b>
800	Internal	TO	Left	<b>3MFS800BCLGTO</b>
400	Internal	T	Right	<b>3MFS400BCRGT</b>
600	Internal	T	Right	<b>3MFS600BCRGT</b>
800	Internal	T	Right	<b>3MFS800BCRGT</b>
400	Internal	T	Left	<b>3MFS400BCLGT</b>
600	Internal	T	Left	<b>3MFS600BCLGT</b>
800	Internal	T	Left	<b>3MFS800BCLGT</b>
400	Housing	TO	Right	<b>3MFS400BCRNTO</b>
600	Housing	TO	Right	<b>3MFS600BCRNTO</b>
800	Housing	TO	Right	<b>3MFS800BCRNTO</b>
400	Housing	TO	Left	<b>3MFS400BCLNTO</b>
600	Housing	TO	Left	<b>3MFS600BCLNTO</b>
800	Housing	TO	Left	<b>3MFS800BCLNTO</b>
400	Housing	T	Right	<b>3MFS400BCRNT</b>
600	Housing	T	Right	<b>3MFS600BCRNT</b>
800	Housing	T	Right	<b>3MFS800BCRNT</b>
400	Housing	T	Left	<b>3MFS400BCLNT</b>
600	Housing	T	Left	<b>3MFS600BCLNT</b>
800	Housing	T	Left	<b>3MFS800BCLNT</b>

**Main Fusible Switch with Busway Connection (3MCB... and 3HMCB...)**

<b>Ampere Rating</b>	<b>Internal Ground or Housing Ground</b>	<b>Standard T or TO Opposite Phasing</b>	<b>Right or Left Side</b>	<b>System Voltage 120/208 Vac Three-Phase, Four-Wire Catalog Number</b>
400	Internal	T	Right	<b>3MCB400BCRGT</b>
400	Internal	T	Right	<b>3HMCB400BCRGT</b>
600	Internal	T	Right	<b>3MCB600BCRGT</b>
600	Internal	T	Right	<b>3HMCB600BCRGT</b>
800	Internal	T	Right	<b>3MCB800BCRGT</b>
800	Internal	T	Right	<b>3HMCB800BCRGT</b>
1000	Internal	T	Right	<b>3MCB1000BCRGT</b>
1000	Internal	T	Right	<b>3HMCB1000BCRGT</b>
1200	Internal	T	Right	<b>3MCB1200BCRGT</b>
1200	Internal	T	Right	<b>3HMCB1200BCRGT</b>
400	Internal	T	Left	<b>3MCB400BCLGT</b>
400	Internal	T	Left	<b>3HMCB400BCLGT</b>
600	Internal	T	Left	<b>3MCB600BCLGT</b>
600	Internal	T	Left	<b>3HMCB600BCLGT</b>
800	Internal	T	Left	<b>3MCB800BCLGT</b>
800	Internal	T	Left	<b>3HMCB800BCLGT</b>
1000	Internal	T	Left	<b>3MCB1000BCLGT</b>
1000	Internal	T	Left	<b>3HMCB1000BCLGT</b>
1200	Internal	T	Left	<b>3MCB1200BCLGT</b>
1200	Internal	T	Left	<b>3HMCB1200BCLGT</b>
400	Housing	T	Right	<b>3MCB400BCRNT</b>
400	Housing	T	Right	<b>3HMCB400BCRNT</b>
600	Housing	T	Right	<b>3MCB600BCRNT</b>
600	Housing	T	Right	<b>3HMCB600BCRNT</b>
800	Housing	T	Right	<b>3MCB800BCRNT</b>
800	Housing	T	Right	<b>3HMCB800BCRNT</b>
1000	Housing	T	Right	<b>3MCB1000BCRNT</b>
1000	Housing	T	Right	<b>3HMCB1000BCRNT</b>
1200	Housing	T	Right	<b>3MCB1200BCRNT</b>
1200	Housing	T	Right	<b>3HMCB1200BCRNT</b>
400	Housing	T	Left	<b>3MCB400BCLNT</b>
400	Housing	T	Left	<b>3HMCB400BCLNT</b>
600	Housing	T	Left	<b>3MCB600BCLNT</b>
600	Housing	T	Left	<b>3HMCB600BCLNT</b>
800	Housing	T	Left	<b>3MCB800BCLNT</b>
800	Housing	T	Left	<b>3HMCB800BCLNT</b>
1000	Housing	T	Left	<b>3MCB1000BCLNT</b>
1000	Housing	T	Left	<b>3HMCB1000BCLNT</b>
1200	Housing	T	Left	<b>3MCB1200BCLNT</b>
1200	Housing	T	Left	<b>3HMCB1200BCLNT</b>
400	Internal	TO	Right	<b>3MCB400BCRGTO</b>
400	Internal	TO	Right	<b>3HMCB400BCRGTO</b>
600	Internal	TO	Right	<b>3MCB600BCRGTO</b>
600	Internal	TO	Right	<b>3HMCB600BCRGTO</b>
800	Internal	TO	Right	<b>3MCB800BCRGTO</b>
800	Internal	TO	Right	<b>3HMCB800BCRGTO</b>

#### Main Fusible Switch with Busway Connection (3MCB... and 3HMCB...), continued

Ampere Rating	Internal Ground or Housing Ground	Standard T or TO Opposite Phasing	Right or Left Side	System Voltage 120/208 Vac Three-Phase, Four-Wire Catalog Number
1000	Internal	TO	Right	<b>3MCB1000BCRGTO</b>
1000	Internal	TO	Right	<b>3HMCB1000BCRGTO</b>
1200	Internal	TO	Right	<b>3MCB1200BCRGTO</b>
1200	Internal	TO	Right	<b>3HMCB1200BCRGTO</b>
400	Internal	TO	Left	<b>3MCB400BCLGTO</b>
400	Internal	TO	Left	<b>3HMCB400BCLGTO</b>
600	Internal	TO	Left	<b>3MCB600BCLGTO</b>
600	Internal	TO	Left	<b>3HMCB600BCLGTO</b>
800	Internal	TO	Left	<b>3MCB800BCLGTO</b>
800	Internal	TO	Left	<b>3HMCB800BCLGTO</b>
1000	Internal	TO	Left	<b>3MCB1000BCLGTO</b>
1000	Internal	TO	Left	<b>3HMCB1000BCLGTO</b>
1200	Internal	TO	Left	<b>3MCB1200BCLGTO</b>
1200	Internal	TO	Left	<b>3HMCB1200BCLGTO</b>
400	Housing	TO	Right	<b>3MCB400BCRNTO</b>
400	Housing	TO	Right	<b>3HMCB400BCRNTO</b>
600	Housing	TO	Right	<b>3MCB600BCRNTO</b>
600	Housing	TO	Right	<b>3HMCB600BCRNTO</b>
800	Housing	TO	Right	<b>3MCB800BCRNTO</b>
800	Housing	TO	Right	<b>3HMCB800BCRNTO</b>
1000	Housing	TO	Right	<b>3MCB1000BCRNTO</b>
1000	Housing	TO	Right	<b>3HMCB1000BCRNTO</b>
1200	Housing	TO	Right	<b>3MCB1200BCRNTO</b>
1200	Housing	TO	Right	<b>3HMCB1200BCRNTO</b>
400	Housing	TO	Left	<b>3MCB400BCLNTO</b>
400	Housing	TO	Left	<b>3HMCB400BCLNTO</b>
600	Housing	TO	Left	<b>3MCB600BCLNTO</b>
600	Housing	TO	Left	<b>3HMCB600BCLNTO</b>
800	Housing	TO	Left	<b>3HMCB800BCLNTO</b>
800	Housing	TO	Left	<b>3HMCB800BCLNTO</b>
1000	Housing	TO	Left	<b>3MCB1000BCLNTO</b>
1000	Housing	TO	Left	<b>3HMCB1000BCLNTO</b>
1200	Housing	TO	Left	<b>3MCB1200BCLNTO</b>
1200	Housing	TO	Left	<b>3HMCB1200BCLNTO</b>

**Dimensions**

Approximate Dimensions in Inches (mm)

**Dimensions (Not to be Used for Construction Purposes)**

Main Device	Width A	Height B	Depth C	Mounting D	E	Center Line of Wall Mounting Bracket F	Knockouts in Bottom Endwalls and Top Feed Switch or Bolted Pressure Switch Conduit Diameter		KO Dwg
							Inches	mm	
<b>Terminal Box</b>									
400 and 600 A	13.50 (342.9)	48.75 (1238.3)	7.00 (177.8)	—	54.00 (1371.6)	30.63 (777.9)	(1) 2.50, 3.00, 3.50, 4.00 (1) 0.50	(1) 63.5, 76.2, 88.9, 101.6 (1) 12.7	1
800 and 1200 A	20.00 (508.0)	47.63 (1209.8)	11.75 (298.5)	12.00 (304.8)	51.50 (1308.1)	30.63 (777.9)	(2) 0.50, 0.75, 1.00	(2) 12.1, 19.1, 25.4	8
1600 A	32.88 (835.2)	60.13 (1527.3)	11.44 (290.6)	16.00 (406.4)	64.13 (1628.9)	38.59 (980.2)	(1) 0.75, 1.00, 1.25, 1.50 (5) 3.00, 3.50, 4.00, 5.00	(1) 19.1, 25.4, 31.8, 38.1 (5) 76.2, 88.9, 101.6, 127.0	3
<b>Main Circuit Breaker with Box Lugs</b>									
400–1200 A	20.00 (508.0)	47.63 (1209.8)	11.75 (298.5)	12.00 (304.8)	51.50 (1308.1)	30.63 (777.9)	(2) 0.50, 0.75, 1.00	(2) 12.7, 19.1, 25.4	8
1400–2000 A	24.88 (632.0)	57.13 (1451.0)	14.88 (378.0)	16.00 (406.4)	57.13 (1451.0)	44.00 (1117.6)	—	—	—
<b>Main Circuit Breaker with Compression Lugs</b>									
400–1200 A	20.00 (508.0)	61.00 (1549.4)	11.75 (298.5)	12.00 (304.8)	65.00 (1651.0)	44.00 (1117.6)	(2) 0.50, 0.75, 1.00	(2) 12.7, 19.1, 25.4	8
<b>Main Fusible Switch</b>									
Bottom feed 400–800 A	20.00 (508.0)	47.63 (1209.8)	11.75 (298.5)	12.00 (304.8)	51.50 (1308.1)	30.63 (777.9)	(2) 0.50, 0.75, 1.00	(2) 12.7, 19.1, 25.4	8
Top feed 400–800 A	20.00 (508.0)	47.63 (1209.8)	11.75 (298.5)	12.00 (304.8)	51.50 (1308.1)	18.13 (460.4)	(2) 0.50, 0.75, 1.00	(2) 12.7, 19.1, 25.4	8
1200 A	33.50 (850.9)	52.75 (1339.9)	11.88 (301.8)	16.00 (406.4)	56.25 (1428.8)	30.75 (781.1)	(5) 3.50, 4.00, 5.00 (1) 0.75, 1.00, 1.25, 1.50	(5) 88.9, 101.6, 127.0 (1) 19.1, 25.4, 31.8, 38.1	2
<b>Bolted Pressure Switch</b>									
	36.50 (927.1)	66.50 (1689.1)	19.50 (495.3)	28.00 (711.2)	60.00 (1524.0)	30.63 (777.9)	—	—	—
<b>Main Fusible Switch with Pull Box</b>									
400 A	20.00 (508.0)	61.00 (1549.4)	11.75 (298.5)	12.00 (304.8)	65.00 (1651.0)	44.00 (1117.6)	(2) 0.50, 0.75, 1.00 (4) 2.00, 2.50, 3.00, 3.50, 4.00	(2) 12.7, 19.1, 25.4 (4) 50.8, 63.5, 76.2, 88.9, 101.6	2
600 and 800 A (single-phase)	20.00 (508.0)	61.00 (1549.4)	11.75 (298.5)	12.00 (304.8)	65.00 (1651.0)	44.00 (1117.6)	(2) 0.50, 0.75, 1.00 (4) 2.00, 2.50, 3.00, 3.50, 4.00	(2) 12.7, 19.1, 25.4 (4) 50.8, 63.5, 76.2, 88.9, 101.6	2
600 and 800 A (three-phase)	25.06 (636.5)	61.00 (1549.4)	11.75 (298.5)	17.00 (431.8)	65.00 (1651.0)	44.00 (1117.6)	(2) 0.50, 0.75, 1.00 (4) 2.00, 2.50, 3.00, 3.50, 4.00	(2) 12.7, 19.1, 25.4 (4) 50.8, 63.5, 76.2, 88.9, 101.6	2
1200 A	33.50 (850.9)	61.50 (1562.1)	11.88 (301.8)	16.00 (406.4)	65.25 (1657.4)	48.00 (1219.2)	(5) 3.50, 4.00, 5.00 (1) 0.75, 1.00, 1.25, 1.50	(5) 88.9, 101.6, 127.0 (1) 19.1, 25.4, 31.8, 38.1	2
<b>Main Circuit Breaker with Pull Box (EUSERC)</b>									
400 A	20.01 (508.2)	60.44 (1535.2)	11.14 (283.0)	12.00 (304.8)	65.11 (1653.8)	39.75 (1009.6)	(4) 2.50, 3.00, 3.50, 4.00	(4) 63.5, 76.2, 88.9, 101.6	2
800 A	24.88 (632.0)	60.94 (1547.9)	11.14 (283.0)	17.00 (431.8)	64.88 (1648.0)	39.81 (1011.2)	(4) 2.50, 3.00, 3.50, 4.00	(4) 63.5, 76.2, 88.9, 101.6	2
1200 A	33.00 (838.2)	61.14 (1553.0)	11.32 (287.5)	16.00 (406.4)	65.25 (1657.4)	43.56 (1106.4)	(4) 2.50, 3.00, 3.50, 4.00	(4) 63.5, 76.2, 88.9, 101.6	2
<b>Pull Box</b>									
400 A	16.38 (416.1)	44.88 (1140.0)	7.88 (200.2)	8.00 (203.2)	45.75 (1162.1)	28.63 (727.2)	(2) 4.00	101.6	4
800 A	24.38 (619.3)	46.88 (1190.8)	11.88 (301.8)	12.00 (304.8)	47.75 (1212.9)	32.25 (819.2)	(3) 4.00	101.6	5
1200 A	32.50 (825.5)	56.88 (1444.8)	12.00 (304.8)	17.75 (450.9)	57.75 (1466.9)	42.25 (1073.2)	(4) 5.00	127.0	6
<b>EUSERC Bussed Pull Section</b>									
Single-phase 400 and 800 A	20.13 (511.3)	61.00 (1549.4)	11.25 (285.8)	12.00 (304.8)	64.88 (1648.0)	44.00 (1117.6)	(4) 2.50, 3.00, 3.50, 4.00	(4) 63.5, 76.2, 88.9, 101.6	4
Three-phase 400 and 800 A	25.13 (638.3)	61.00 (1549.4)	11.88 (301.8)	17.00 (431.8)	64.88 (1648.0)	44.00 (1117.6)	(4) 2.50, 3.00, 3.50, 4.00	(4) 63.5, 76.2, 88.9, 101.6	5
<b>EUSERC Main Terminal Box</b>									
Single-phase 400 and 800 A	20.13 (511.3)	61.00 (1549.4)	11.88 (301.8)	12.00 (304.8)	64.88 (1648.0)	44.00 (1117.6)	(2) 0.50, 0.75, 1.00	(2) 12.7, 19.1, 25.4	2
Three-phase 400 A	20.13 (511.3)	61.00 (1549.4)	11.88 (301.8)	12.00 (304.8)	64.88 (1648.0)	44.00 (1117.6)	(4) 2.00, 2.50, 3.00, 3.50, 4.00	(4) 50.8, 63.5, 76.2, 88.9, 101.6	2
Three-phase 800 A	25.13 (638.3)	61.00 (1549.4)	11.88 (301.8)	17.00 (431.8)	64.88 (1648.0)	44.00 (1117.6)	(4) 2.00, 2.50, 3.00, 3.50, 4.00	(4) 50.8, 63.5, 76.2, 88.9, 101.6	2

# 4.3

## Metering Products

### Group Metering

4

Approximate Dimensions in Inches (mm)

#### Main Circuit Breakers, Terminal Boxes and Pull Boxes

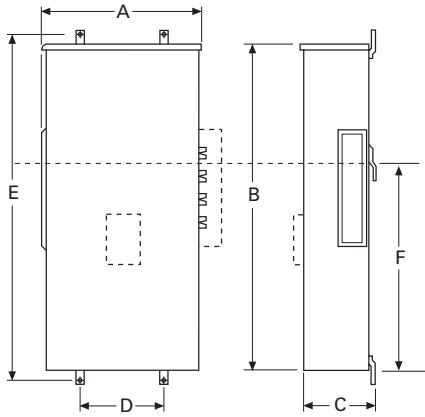

Main CB, Non-Euserc Terminal Box and Pullboxes

#### Bolted Pressure Switch

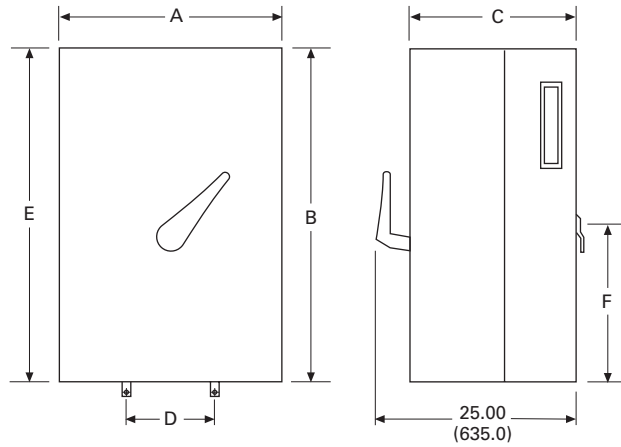

#### Top Feed Fusible Switch

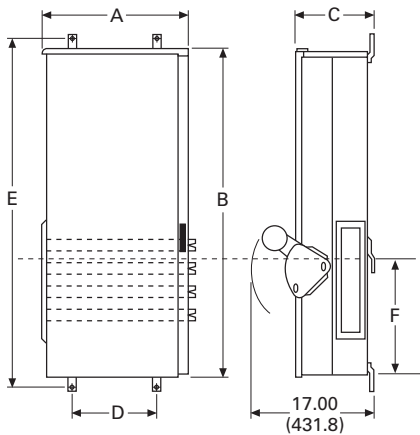

Top Feed Switch (No Knockouts)

#### EUSERC Main Terminal Box

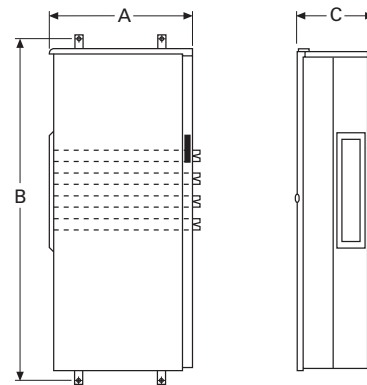

#### Bottom Feed Fusible Switch and Combination Fusible Switch with Pull Box

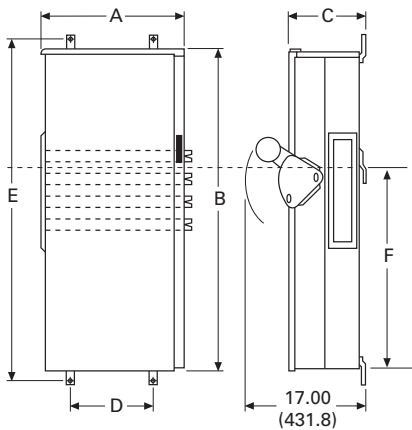

Bottom Feed Switch and Combination Switch/Pullbox

Approximate Dimensions in Inches (mm)

Knockout 1

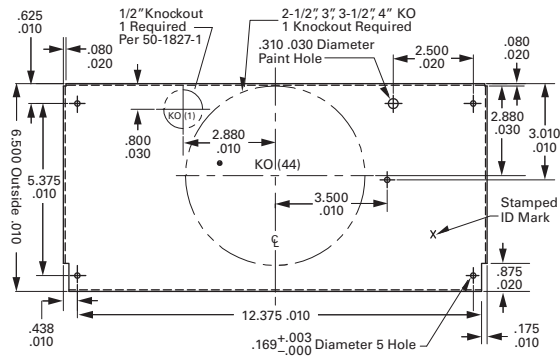

Knockout 2

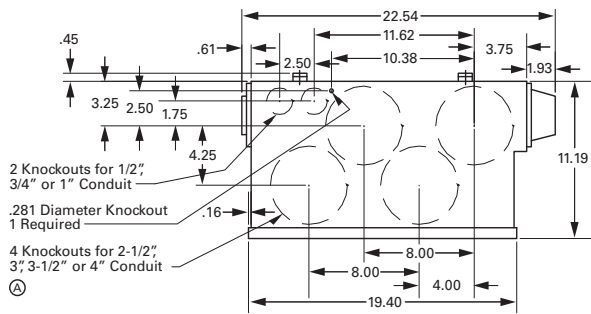

Knockout 3

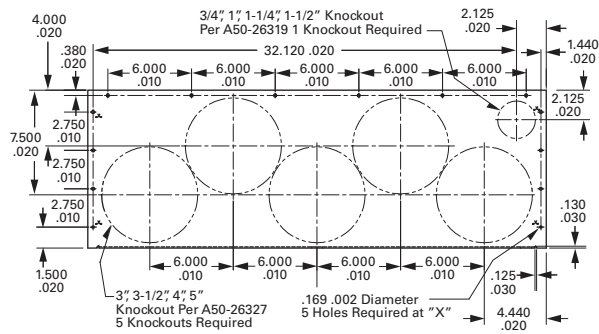

Knockout 4

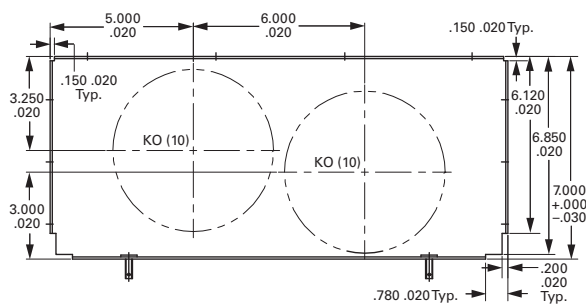

Knockout 5

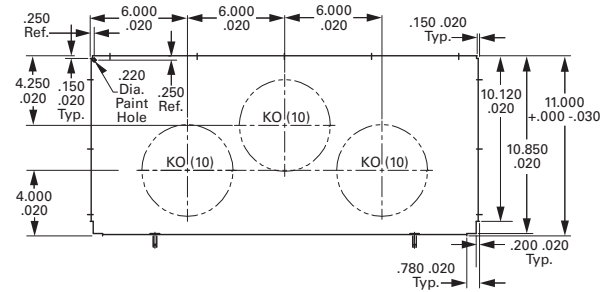

Knockout 6

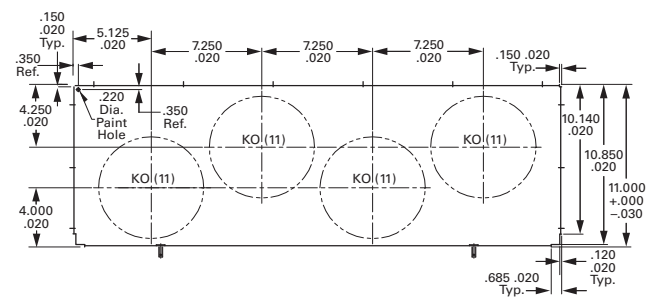

Knockout 7

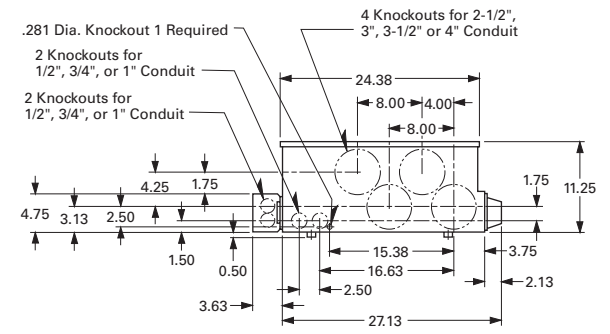

Knockout 8

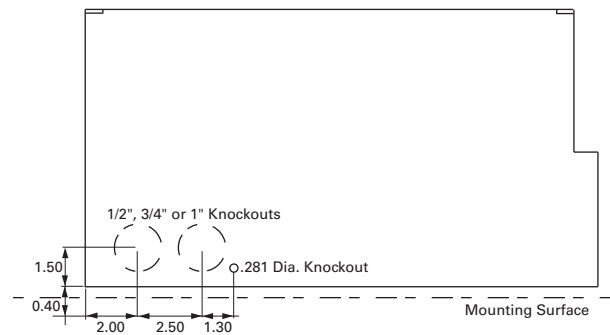

# 4.3

## Metering Products

### Group Metering

Approximate Dimensions in Inches (mm)

#### Layout—Main Fusible Switch

4

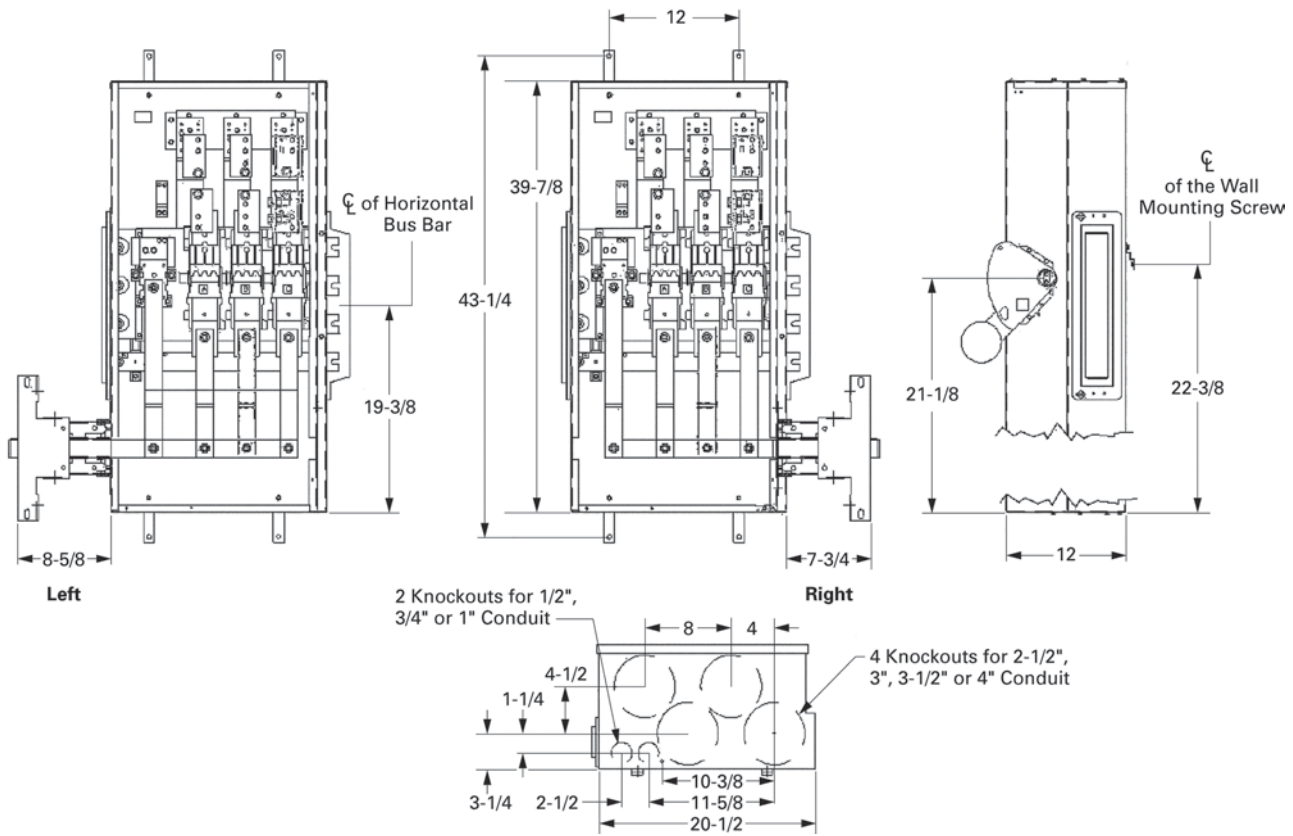

Approximate Dimensions in Inches (mm)

Main Circuit Breaker—“T-Opposite” Phasing Right

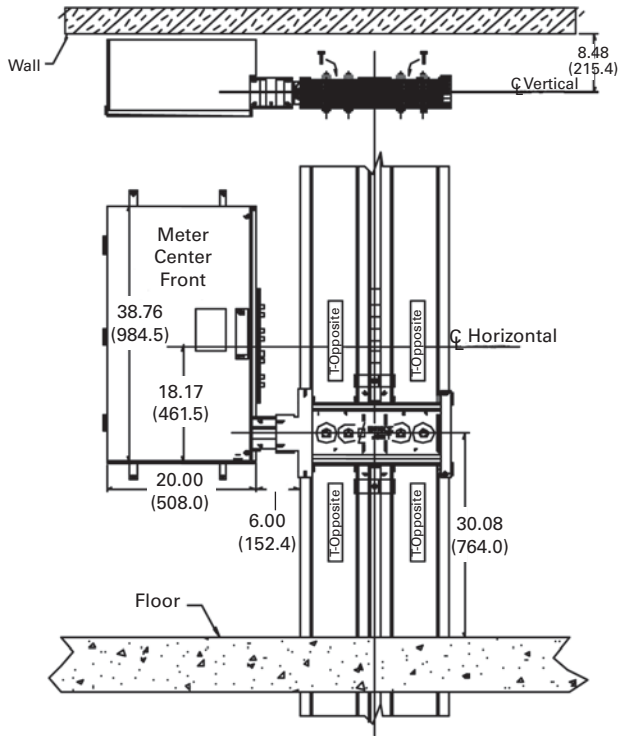

Main Circuit Breaker—“Standard T” Phasing Right

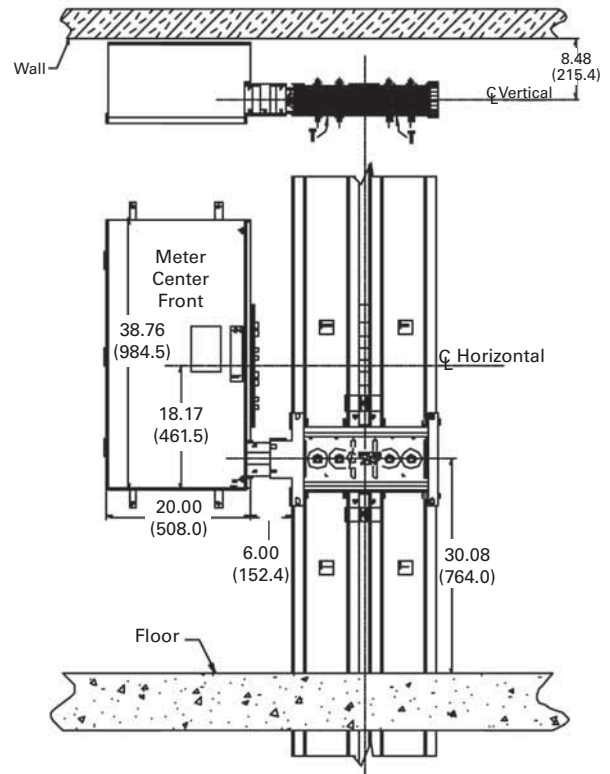

Main Circuit Breaker—“T-Opposite” Phasing Left

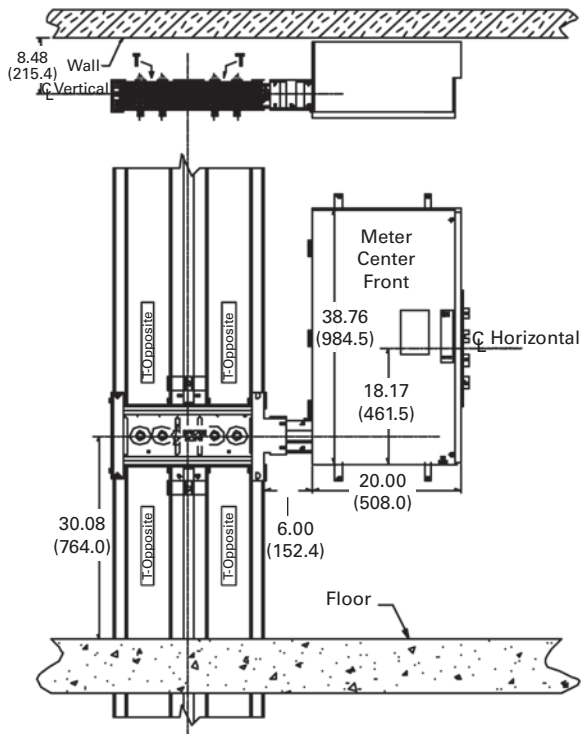

Main Circuit Breaker—“Standard T” Phasing Left

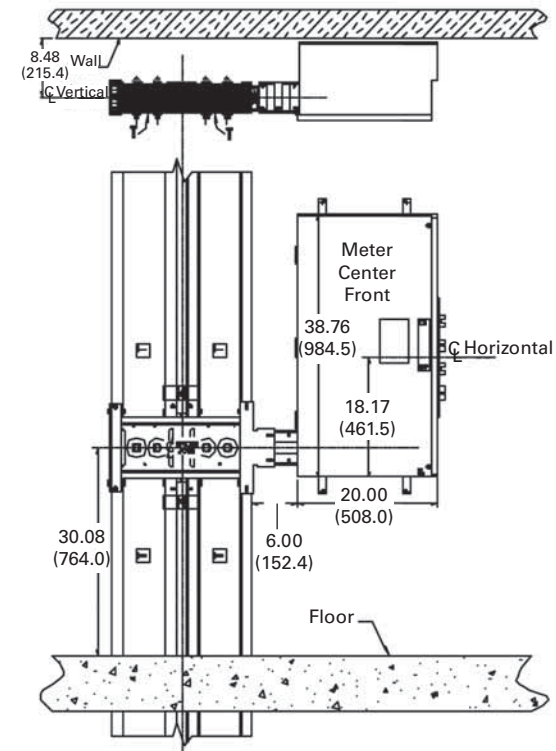



#### 1MM and 3MM Metering Stack Modules



#### Contents

<i>Description</i>	<i>Page</i>
Systems for Residential and Commercial Applications . . . . .	<b>V1-T4-68</b>
Meter Packs . . . . .	<b>V1-T4-76</b>
Meter Packs—Tenant Circuit Breakers . . . . .	<b>V1-T4-88</b>
Main Service Modules . . . . .	<b>V1-T4-89</b>
Residential Meter Stacks	
Catalog Number Selection . . . . .	<b>V1-T4-109</b>
Product Selection . . . . .	<b>V1-T4-110</b>
Technical Data and Specifications . . . . .	<b>V1-T4-114</b>
Dimensions . . . . .	<b>V1-T4-115</b>
Commercial Meter Stack Modules . . . . .	<b>V1-T4-123</b>
35MM, 37MM, 35SS and 37SS Tenant Main Circuit Breakers . . . . .	<b>V1-T4-130</b>
Phase Balanced Stack . . . . .	<b>V1-T4-132</b>
Group Metering Inline Current Transformer Cabinets . . . . .	<b>V1-T4-133</b>
Surge Metering . . . . .	<b>V1-T4-134</b>
Group Metering Accessories . . . . .	<b>V1-T4-135</b>

### Residential Meter Stacks—(1MP, 1MM and 3MM Tenant Main Circuit Breakers)

#### Features, Benefits and Functions

##### A. Barrier

Meter socket and tenant main breaker/wireway sections are separated by a solid metal barrier to guard un-metered bus against power theft.

##### B. Tenant Breaker

Reliable busbar-to-busbar connection. 200 A modules accept bolt-on breakers 60–200 A. 125 A modules accept 15–125 A plug-on breakers.

##### C. Moveable Phase Connector

Four-wire horizontal bus lets you use any 3MM module for single- or three-phase incoming service. Shipped with A and B phase connection, phase balancing is easily accomplished in the field by moving one, front-accessible phase connector post per module.

##### D. Neutral Assembly

A convenient termination for neutral conductors is in the wireway of each module.

##### E. Enclosed Horizontal Bus

Added security because a non-removable barrier encloses the 800 or 1200 A horizontal bus passing through tenant breaker section.

##### F. Equipment Ground Bar

Factory installed in side gutter, a standard feature that's moveable to the top or bottom gutter.

##### G. Raintight Cap

Shipped on each outdoor meter module and main device.

##### H. Knockouts

Tangential in bottom endwall.

##### I. Superior Finish

Rust inhibiting phosphate primer and gray baked enamel is standard. All outdoor enclosures are of galvanized steel construction.

##### J. Meter Socket

Our unique meter socket base is installed without any fasteners—reducing chances for hot spots, easily replaceable, and improves connection to vertical bus.

##### K. Bus Connection

Mains and modules slip together quickly and smoothly with front-accessible captive bolts securing the juncture without removing socket interiors or bus access plate. Main bus joint bolts torque to 25 foot pounds.

##### L. Separate Wireway Cover

Separate covers allow easy access to tenant breaker and wireway section, permit work on breakers or in wireway without disturbing meters or meter covers. (Not shown.)

##### M. Vertical Busbar

One-piece vertical busbar from phase balancing joints to meter socket eliminating any chance for hot spots.

#### 1MM Meter Stack Module

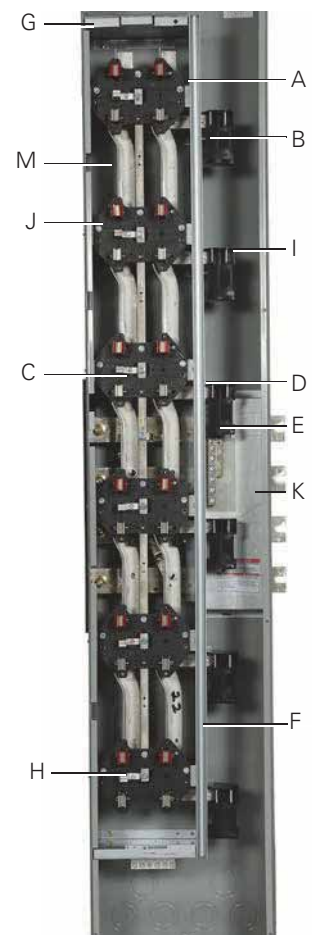

- Eaton's 1MM stacks are single-phase in, single-phase out design
- Eaton's 3MM stacks are three-phase in, single-phase out design
- Stacks with single-phase horizontal bus are rated 240/120 V, single-phase, three-wire. Stacks with three-phase horizontal bus are rated 208Y/120 V, three-phase, four-wire, but can be used on 240/120 V, three-phase, four-wire delta systems
- All three-phase horizontal bus modules have four-wire cross bus, connected A-B phase to vertical bus, readily reconnectable for phase balance on installation
- Note:** Individual sockets cannot be phase balanced, only each stack.
- Short-circuit ratings up to 100,000 A rms symmetrical depending upon AIC rating of installed main tenant circuit breakers and main device
- Main tenant feeders can exit bottom or back. Knockouts are available at all exit locations
- If being used in outdoor application and exiting the top, mount Myer type hubs on rainproof cap
- Provision for two-pole breaker (plug-on type for 125 A sockets and bolt-on type for 200 A sockets)—circuit breakers not included
- Mechanically and electrically built to bolt-up with main service modules and commercial modular metering stacks
- Aluminum or copper bus
- 800 or 1200 A horizontal bus
- All 3MM stacks include fifth jaw at 9 o'clock position
- All 1MM stacks do not include fifth jaw. Order 1MM5JK if needed

### Catalog Number Selection

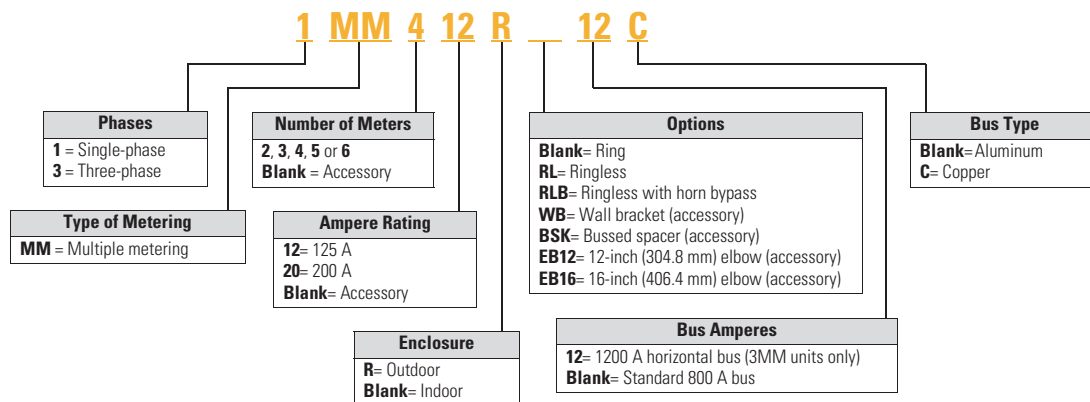

### When Ordering:

- Determine catalog number of Main Service Module.
- Determine catalog number of Meter Stack (Residential or Commercial).
- Find quantity and catalog numbers for tenant circuit breakers (found on **Page V1-T4-125** or **V1-T4-131**). Order one breaker per socket.
- If any accessories are needed, order from **Pages V1-T4-136** and **V1-T4-137**.

#### Product Selection

1MM and 3MM  
Metering Stack  
Modules



4

#### 800 A Horizontal Aluminum Bus—Standard Offering

Amperes Per Meter Socket	Number of Meter Sockets	Bus Ampacity	Enclosure Type <sup>①</sup>	Main Tenant Breaker Type (For Specific Catalog Numbers, Refer to Page V1-T4-125)	Single-Phase In, Single-Phase Out	Three-Phase In, Single-Phase Out
					Single-Phase Horizontal Bus (Three Horizontal Busbars—A, B and Neutral) <sup>②</sup> Catalog Number	Three-Phase Horizontal Bus (Four Horizontal Busbars—A, B, C and Neutral) Catalog Number
<b>Ring Style Meter Socket Covers <sup>③</sup></b>						
125 <sup>④</sup>	2 <sup>⑤</sup>	800	Indoor/outdoor	Plug-on type	Use three-phase	<b>3MM212R</b>
	3 <sup>⑤</sup>	800	Indoor/outdoor	BR2_ BRH2_	<b>1MM312R</b>	<b>3MM312R</b>
	4	800	Indoor/outdoor	BRHH2_ BRX2_	<b>1MM412R</b>	<b>3MM412R</b>
	5	800	Indoor/outdoor		<b>1MM512R</b>	<b>3MM512R</b>
	6	800	Indoor/outdoor		<b>1MM612R</b>	<b>3MM612R</b>
	200 <sup>⑥</sup>	2	800	Outdoor	Bolt-on type	Use three-phase
3		800	Outdoor	CCV2_X CCVH2_X	<b>1MM320R</b>	<b>3MM320R</b>
4		800	Outdoor	CVS2_XMM CV2_XMM	<b>1MM420R</b>	<b>3MM420R</b>
5		800	Outdoor	CVH2_XMM	<b>1MM520R</b> <sup>⑦</sup>	<b>3MM520R</b> <sup>⑧</sup>
<b>Ringless Style Meter Socket Covers</b>						
125	2	800	Outdoor	Plug-on type	Use three-phase	<b>3MM212RRL</b>
	3	800	Outdoor	BR2_ BRH2_	<b>1MM312RRL</b>	<b>3MM312RRL</b>
	4	800	Outdoor	BRHH2_ BRX2_	<b>1MM412RRL</b>	<b>3MM412RRL</b>
	5	800	Outdoor		<b>1MM512RRL</b>	<b>3MM512RRL</b>
	6	800	Outdoor		<b>1MM612RRL</b>	<b>3MM612RRL</b>
	200	2	800	Outdoor	Bolt-on type	Use three-phase
3		800	Outdoor	CCV2_X CCVH2_X	<b>1MM320RRL</b>	<b>3MM320RRL</b>
4		800	Outdoor	CVS2_XMM CV2_XMM	<b>1MM420RRL</b>	<b>3MM420RRL</b>
5		800	Outdoor	CVH2_XMM	<b>1MM520RRL</b> <sup>⑦</sup>	<b>3MM520RRL</b> <sup>⑧</sup>
<b>Ringless Style Covers with Horn Bypass</b>						
125	2	800	Outdoor	Plug-on type	Use three-phase	<b>3MM212RRLB</b>
	3	800	Outdoor	BR2_ BRH2_	<b>1MM312RRLB</b>	<b>3MM312RRLB</b>
	4	800	Outdoor	BRHH2_ BRX2_	<b>1MM412RRLB</b>	<b>3MM412RRLB</b>
	5	800	Outdoor		<b>1MM512RRLB</b>	<b>3MM512RRLB</b>
	6	800	Outdoor		<b>1MM612RRLB</b>	<b>3MM612RRLB</b>
	200	2	800	Outdoor	Bolt-on type	Use three-phase
3		800	Outdoor	CCV2_X CCVH2_X	<b>1MM320RRLB</b>	<b>3MM320RRLB</b>
4		800	Outdoor	CVS2_XMM CV2_XMM	<b>1MM420RRLB</b>	<b>3MM420RRLB</b>
5		800	Outdoor	CVH2_XMM	<b>1MM520RRLB</b> <sup>⑦</sup>	<b>3MM520RRLB</b> <sup>⑧</sup>

**Notes**

- ① For indoor applications where a top endwall with knockouts is needed, order one of part number **MM12N1WLK** for each 125 A stack or **MM20N1WLK** for each 200 A stack.
- ② 1MM units do not come with 5th jaw.
- ③ Reference drawing EUSERC DWG-G1, G2, G3.
- ④ To change in field from ring to ringless—order **1MMRC125**.
- ⑤ To change in field from ring to ringless, the top socket in 125 A, two- and three-high stacks use **1MMRC125T**. Top socket only—other sockets see ④.
- ⑥ To change in field from ring to ringless—order **1MMRC200**.
- ⑦ Check with local utility for height requirements or restrictions.

800 A Horizontal Copper Bus—Premium Offering

Amperes Per Meter Socket	Number of Meter Sockets	Bus Ampacity	Enclosure Type ①	Main Tenant Breaker Type (For Specific Catalog Numbers, Refer to Page V1-T4-125)	Single-Phase In, Single-Phase Out Single-Phase Horizontal Bus (Three Horizontal Busbars—A, B, C and Neutral) ② Catalog Number	Three-Phase In, Single-Phase Out Three-Phase Horizontal Bus (Four Horizontal Busbars—A, B, C and Neutral) Catalog Number
<b>Ring Style Meter Socket Covers ③</b>						
125 ④	2 ⑤	800	Outdoor	Plug-on type BR2_	Use three-phase	3MM212RC
	3 ⑤	800	Outdoor	BRH2_	1MM312RC	3MM312RC
	4	800	Outdoor	BRHH2_	1MM412RC	3MM412RC
	5	800	Outdoor	BRX2_	1MM512RC	3MM512RC
	6	800	Outdoor		1MM612RC	3MM612RC
200 ⑥	2	800	Outdoor	Bolt-on type CCV2_X	Use three-phase	3MM220RC
	3	800	Outdoor	CCVH2_X	1MM320RC	3MM320RC
	4	800	Outdoor	CVS2_XMM	1MM420RC	3MM420RC
	5	800	Outdoor	CV2_XMM CVH2_XMM	1MM520RC ⑦	3MM520RC ⑥
<b>Ringless Style Meter Socket Covers</b>						
125	2	800	Outdoor	Plug-on type BR2_	Use three-phase	3MM212RRLC
	3	800	Outdoor	BRH2_	1MM312RRLC	3MM312RRLC
	4	800	Outdoor	BRHH2_	1MM412RRLC	3MM412RRLC
	5	800	Outdoor	BRX2_	1MM512RRLC	3MM512RRLC
	6	800	Outdoor		1MM612RRLC	3MM612RRLC
200	2	800	Outdoor	Bolt-on type CCV2_X	Use three-phase	3MM220RRLC
	3	800	Outdoor	CCVH2_X	1MM320RRLC	3MM320RRLC
	4	800	Outdoor	CVS2_XMM	1MM420RRLC	3MM420RRLC
	5	800	Outdoor	CV2_XMM CVH2_XMM	1MM520RRLC ⑦	3MM520RRLC ⑥
<b>Ringless Style Covers with Horn Bypass</b>						
125	2	800	Outdoor	Plug-on type BR2_	Use three-phase	3MM212RRLBC
	3	800	Outdoor	BRH2_	1MM312RRLBC	3MM312RRLBC
	4	800	Outdoor	BRHH2_	1MM412RRLBC	3MM412RRLBC
	5	800	Outdoor	BRX2_	1MM512RRLBC	3MM512RRLBC
	6	800	Outdoor		1MM612RRLBC	3MM612RRLBC
200	2	800	Outdoor	Bolt-on type CCV2_X	Use three-phase	3MM220RRLBC
	3	800	Outdoor	CCVH2_X	1MM320RRLBC	3MM320RRLBC
	4	800	Outdoor	CVS2_XMM	1MM420RRLBC	3MM420RRLBC
	5	800	Outdoor	CV2_XMM CVH2_XMM	1MM520RRLBC ⑦	3MM520RRLBC ⑥

Notes

- ① For indoor applications where a top endwall with knockouts is needed, order (1) of part number **MM12N1WLK** for each 125 A stack or **MM20N1WLK** for each 200 A stack.
- ② 1MM units do not come with 5th jaw.
- ③ Reference drawing EUSERC DWG-G1, G2, G3.
- ④ To change in field from ring to ringless—order **1MMRC125**.
- ⑤ To change in field from ring to ringless, the top socket in 125 A, two- and three-high stacks use **1MMRC125T**. Top socket only—other sockets see ④.
- ⑥ To change in field from ring to ringless—order **1MMRC200**.
- ⑦ Check with local utility for height requirements or restrictions.

1MM and 3MM Metering Stack Modules



4

#### 1200 A Horizontal Aluminum Bus—Standard Offering

Amperes Per Meter Socket	Number of Meter Sockets	Bus Ampacity	Enclosure Type ①	Main Tenant Breaker Type (For Specific Catalog Numbers, Refer to Page V1-T4-118)	Three-Phase In, Single-Phase Out Three-Phase Horizontal Bus (Four Horizontal Busbars—A, B, C and Neutral) Catalog Number
<b>Ring Style Meter Socket Covers ②</b>					
125 ③	2 ④	1200	Indoor/outdoor	Plug-on type	<b>3MM212R12</b>
	3 ④	1200	Indoor/outdoor	BR2_	<b>3MM312R12</b>
	4	1200	Indoor/outdoor	BRH2_	<b>3MM412R12</b>
	5	1200	Indoor/outdoor	BRHH2_	<b>3MM512R12</b>
	6	1200	Indoor/outdoor	BRX2_	<b>3MM612R12</b>
	200 ⑤	2	1200	Outdoor	Bolt-on type
3		1200	Outdoor	CCV2_X	<b>3MM320R12</b>
4		1200	Outdoor	CCVH2_X	<b>3MM420R12</b>
5		1200	Indoor/outdoor	CVS2_XMM	<b>3MM520R12</b>
				CV2_XMM	<b>3MM620R12</b>
<b>Ringless Style Meter Socket Covers (5th Jaw at 9 o'Clock Standard—Field Adjustable to 3 or 6 o'Clock)</b>					
125	2	1200	Outdoor	Plug-on type	<b>3MM212R12RL</b>
	3	1200	Outdoor	BR2_	<b>3MM312R12RL</b>
	4	1200	Outdoor	BRH2_	<b>3MM412R12RL</b>
	5	1200	Outdoor	BRHH2_	<b>3MM512R12RL</b>
	6	1200	Outdoor	BRX2_	<b>3MM612R12RL</b>
	200	2	1200	Outdoor	Bolt-on type
3		1200	Outdoor	CCV2_X	<b>3MM320R12RL</b>
4		1200	Outdoor	CCVH2_X	<b>3MM420R12RL</b>
5		1200	Outdoor	CVS2_XMM	<b>3MM520R12RL</b>
				CV2_XMM	<b>3MM620R12RL</b>
<b>Ringless Style Covers with Horn Bypass (5th Jaw at 9 o'Clock Standard—Field Adjustable to 3 or 6 o'Clock)</b>					
125	2	1200	Outdoor	Plug-on type	<b>3MM212R12RLB</b>
	3	1200	Outdoor	BR2_	<b>3MM312R12RLB</b>
	4	1200	Outdoor	BRH2_	<b>3MM412R12RLB</b>
	5	1200	Outdoor	BRHH2_	<b>3MM512R12RLB</b>
	6	1200	Outdoor	BRX2_	<b>3MM612R12RLB</b>
	200	2	1200	Outdoor	Bolt-on type
3		1200	Outdoor	CCV2_X	<b>3MM320R12RLB</b>
4		1200	Outdoor	CCVH2_X	<b>3MM420R12RLB</b>
5		1200	Outdoor	CVS2_XMM	<b>3MM520R12RLB</b>
				CV2_XMM	<b>3MM620R12RLB</b>

**Notes**

- ① For indoor applications where a top endwall with knockouts is needed, order (one) of part number **MM12N1WLK** for each 125 A stack or **MM20N1WLK** for each 200 A stack.
- ② Reference drawing EUSERC DWG-G1, G2, G3.
- ③ To change in field from ring to ringless—order **1MMRC125**.
- ④ To change in field from ring to ringless, the top socket in 125 A, two- and three-high stacks use **1MMRC125T**. Top socket only—other sockets see ③.
- ⑤ To change in field from ring to ringless—order **1MMRC200**.

1200 A Horizontal Copper Bus—Premium Offering

Three-Phase In, Single-Phase Out  
Three-Phase Horizontal Bus  
(Four Horizontal Busbars—  
A, B, C and Neutral)  
Catalog Number

Amperes Per Meter Socket	Number of Meter Sockets	Bus Ampacity	Enclosure Type ①	Main Tenant Breaker Type (For Specific Catalog Numbers, Refer to Page V1-T4-118)	
<b>Ring Style Meter Socket Covers ②</b>					
125 ③	2 ④	1200	Indoor/outdoor	Plug-on type	3MM212R12C
	3 ④	1200	Indoor/outdoor	BR2_ BRH2_	3MM312R12C
	4	1200	Indoor/outdoor	BRHH2_	3MM412R12C
	5	1200	Indoor/outdoor	BRX2_ BRHX2_	3MM512R12C
	6	1200	Indoor/outdoor		3MM612R12C
	200 ⑤	2	1200	Outdoor	Bolt-on type
3		1200	Outdoor	CCV2_X CCVH2_X	3MM320R12C
4		1200	Outdoor	CVS2_XMM	3MM420R12C
5		1200	Outdoor	CV2_XMM CVH2_XMM	3MM520R12C
<b>Ringless Style Meter Socket Covers (5th Jaw at 9 o’Clock Standard—Field Adjustable to 3 or 6 o’Clock)</b>					
125	2	1200	Outdoor	Plug-on type	3MM212R12RLC
	3	1200	Outdoor	BR2_ BRH2_	3MM312R12RLC
	4	1200	Outdoor	BRHH2_	3MM412R12RLC
	5	1200	Outdoor	BRX2_ BRHX2_	3MM512R12RLC
	6	1200	Outdoor		3MM612R12RLC
	200	2	1200	Outdoor	Bolt-on type
3		1200	Outdoor	CCV2_X CCVH2_X	3MM320R12RLC
4		1200	Outdoor	CVS2_XMM	3MM420R12RLC
5		1200	Outdoor	CV2_XMM CVH2_XMM	3MM520R12RLC
<b>Ringless Style Covers with Horn Bypass (5th Jaw at 9 o’Clock Standard—Field Adjustable to 3 or 6 o’Clock)</b>					
125	2	1200	Outdoor	Plug-on type	3MM212R12RLBC
	3	1200	Outdoor	BR2_ BRH2_	3MM312R12RLBC
	4	1200	Outdoor	BRHH2_	3MM412R12RLBC
	5	1200	Outdoor	BRX2_ BRHX2_	3MM512R12RLBC
	6	1200	Outdoor		3MM612R12RLBC
	200	2	1200	Outdoor	Bolt-on type
3		1200	Outdoor	CCV2_X CCVH2_X	3MM320R12RLBC
4		1200	Outdoor	CVS2_XMM	3MM420R12RLBC
5		1200	Outdoor	CV2_XMM CVH2_XMM	3MM520R12RLBC

Notes

- ① For indoor applications where a top endwall with knockouts is needed, order (one) of part number **MM12N1WLK** for each 125 A stack or **MM20N1WLK** for each 200 A stack.
- ② Reference drawing EUSERC DWG-G1, G2, G3.
- ③ To change in field from ring to ringless—order **1MMRC125**.
- ④ To change in field from ring to ringless, the top socket in 125 A, two- and three-high stacks use **1MMRC125T**. Top socket only—other sockets see ③.
- ⑤ To change in field from ring to ringless—order **1MMRC200**.

#### Technical Data and Specifications

##### Wire Sizes—Neutral and Ground Lugs

- Each stack includes a neutral and ground bar
- If an extra ground bar is needed, order **1MMGBK**

##### Wire Sizes—Neutral and Ground Lugs

Lugs in Meter Socket Modules	Wire Size, Al/Cu
Branch neutral—125 A socket module	#6–2/0 kcmil
Branch neutral—200 A socket module	#1/0–300 kcmil
Equipment ground bar—125 A socket module	#14–#2 kcmil
Equipment ground bar—200 A socket module	#14–2/0 kcmil
Optional ground bar ( <b>1MMGBK</b> )	#6–2/0 kcmil

##### Notes

- ① For indoor applications where a top endwall with knockouts is needed, order (one) of part number **MM12N1WLK** for each 125 A stack or **MM20N1WLK** for each 200 A stack.
- ② Reference drawing EUSERC DWG-G1, G2, G3.
- ③ To change in field from ring to ringless—order **1MMRC125**.
- ④ To change in field from ring to ringless, the top socket in 125 A, two- and three-high stacks use **1MMRC125T**. Top socket only—other sockets see ③.
- ⑤ To change in field from ring to ringless—order **1MMRC200**.

#### Phase Balancing

All 3MM meter modules come factory connected to phase A and B, per Figure A. When connected to a 208Y/120 Vac three-phase, four-wire system, field phase balancing of two out of every three stacks is required. One of every three stacks should be phased AC, per Figure B, and one of every three stacks should be phased CB, per Figure C.

#### Examples:

**Nine Total Positions**—use (three) three-position stacks and phase one per Figure B (A-C phasing) and one per Figure C (C-B phasing).

**16 Total Positions**—use (two) five-position and (two) three-position stacks. Phase balance (one) five-position per Figure B (A-C phasing) and (one) five-position per Figure C (C-B phasing).

**19 Total Positions**—where four-position maximum height is allowed by utility. Use (one) four-position and (five) three-position stacks. Phase balance (two) three-position stacks per Figure B (A-C phasing) and (two) three-position stacks per Figure C (C-B phasing).

#### "Z" Shaped and "Barrel" Shaped Phase Connector

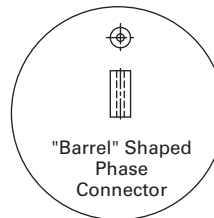
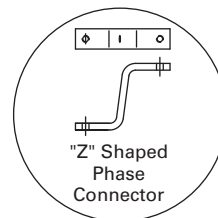

**Dimensions**

Approximate Dimensions in Inches (mm)

**Modular Metering Stacks—Aluminum and Copper**

**3-High, 4-High, 5-High and 6-High, 125 Amperes, 1MM, 3MM**

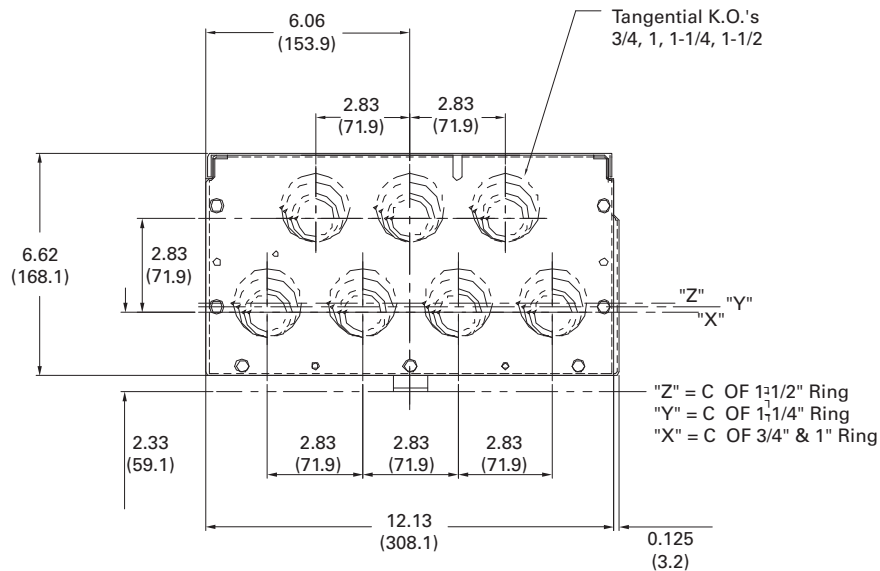
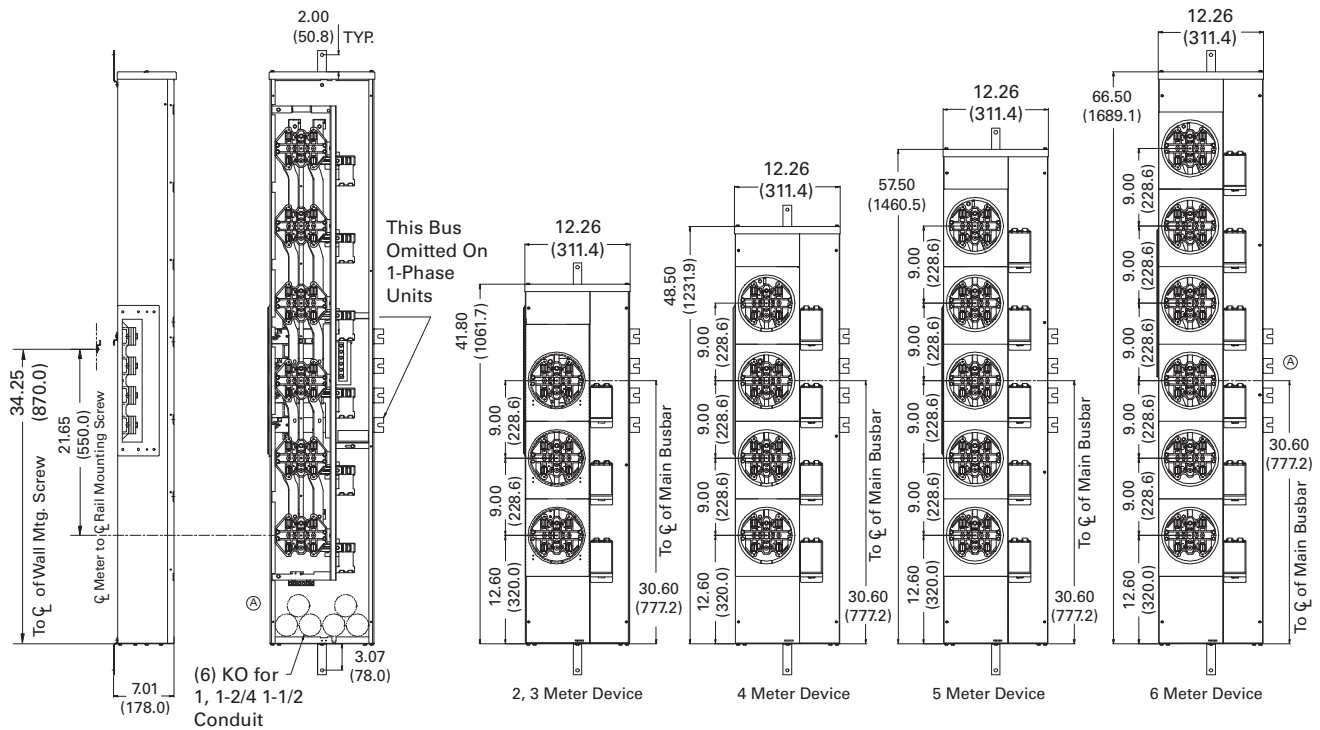

Top End & Bottom End View for NEMA 1;  
Bottom End View for NEMA 3R

**Note:** Dimensions Apply to 800 and 1200 Ampere Horizontal Bus.



# 4.3

## Metering Products

### Group Metering

Approximate Dimensions in Inches (mm)

#### Modular Metering Stacks—Aluminum and Copper

#### 3-High and 4-High, 200 Amperes, 1MM, 3MM

4

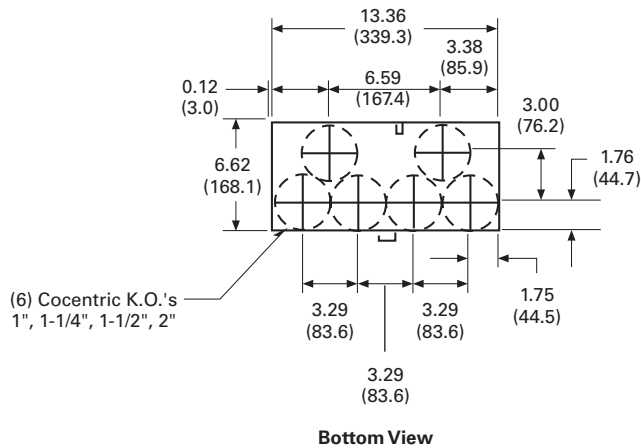
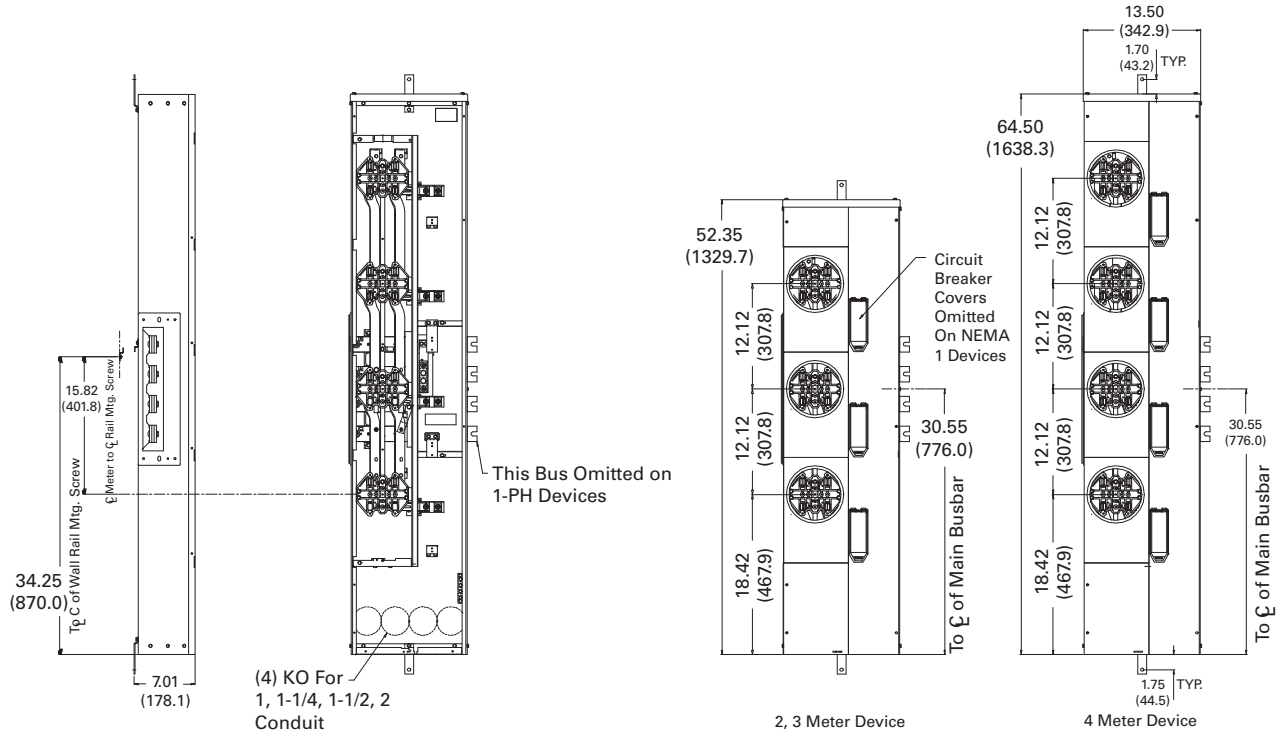

**Note:** Dimensions Apply to 800 and 1200 Ampere Horizontal Bus.

Approximate Dimensions in Inches (mm)

5-High, 200 Amperes, 1MM and 3MM Metering

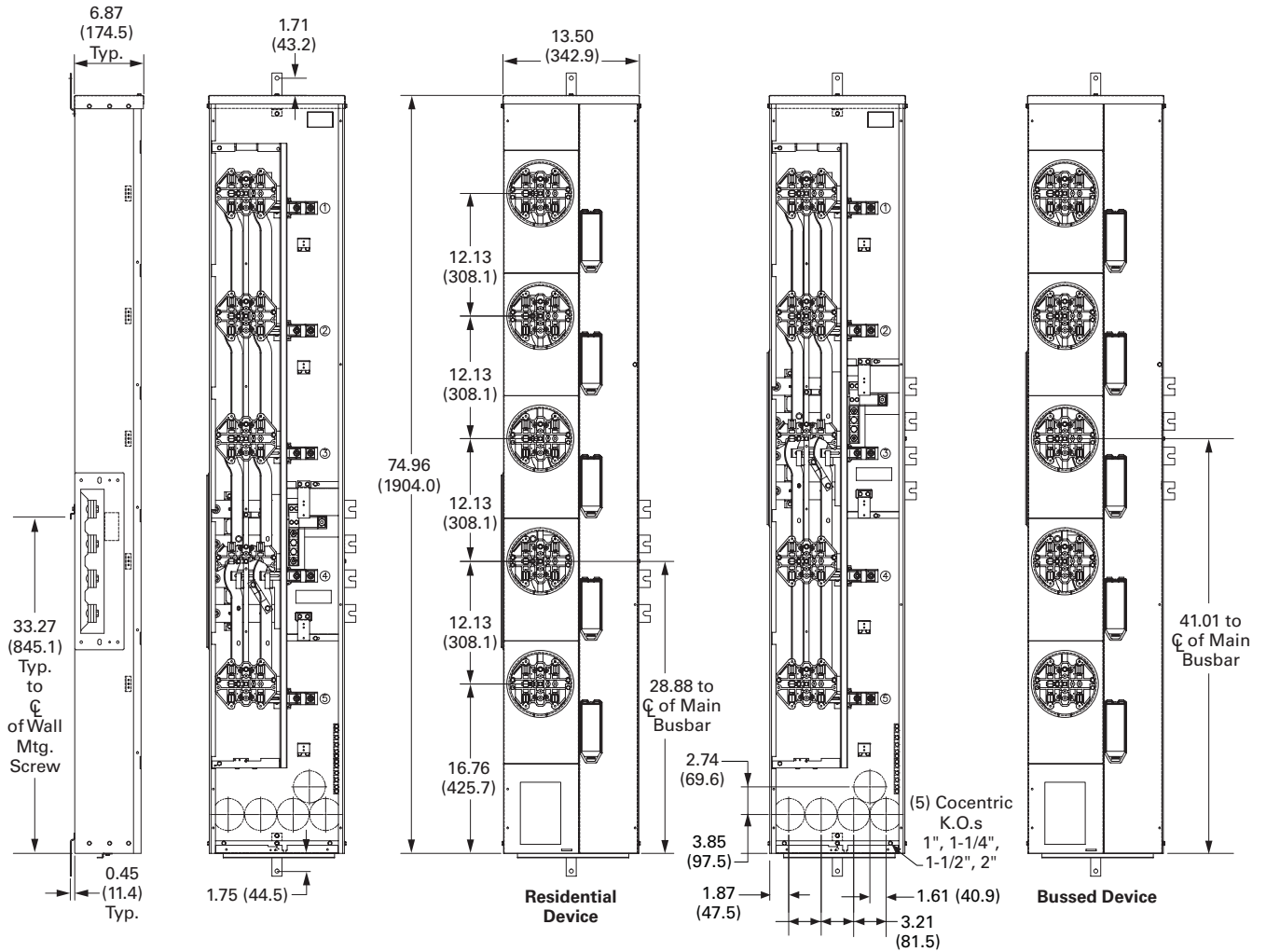

**Note:** The Bussed meter stack device shown on the far right of the figure, must be used on Mains with Busway connections, found on Pages V1-T4-100 and V1-T4-106. Please contact factory for catalog numbers associated with Bussed meter stack devices.

Type BR Tenant Main Circuit Breaker



### Contents

<b>Description</b>	<b>Page</b>
Systems for Residential and Commercial Applications . . . . .	<b>V1-T4-68</b>
Meter Packs . . . . .	<b>V1-T4-76</b>
Meter Packs—Tenant Circuit Breakers . . . . .	<b>V1-T4-88</b>
Main Service Modules . . . . .	<b>V1-T4-89</b>
Residential Meter Stacks . . . . .	<b>V1-T4-108</b>
Commercial Meter Stack Modules . . . . .	<b>V1-T4-123</b>
35MM, 37MM, 35SS and 37SS Tenant Main Circuit Breakers . . . . .	<b>V1-T4-130</b>
Phase Balanced Stack . . . . .	<b>V1-T4-132</b>
Group Metering Inline Current Transformer Cabinets . . . . .	<b>V1-T4-133</b>
Surge Metering . . . . .	<b>V1-T4-134</b>
Group Metering Accessories . . . . .	<b>V1-T4-135</b>

### Type BR 120/240 V

#### Product Overview

Eaton offers Type BR family of circuit breakers as the plug-on tenant main breakers used in group metering applications.

#### Product Description

Eaton’s residential products Type BR circuit breaker is available in a two-pole configuration for group metering applications from 60 A to 125 A in 10, 22, 42 and 65 kAIC ratings.

#### Features

- **Ratings**—120/240 Vac, two-pole, through 125 A continuous amperages, calibrated at 40 °C
- **Tripping characteristics**—thermal-magnetic trip
- **Interrupting capacity** at 120/240 Vac
  - BR—10,000 A rms symmetrical
  - BRH—22,000 A rms symmetrical
  - BRHX—22,000 A rms symmetrical
  - BRHH—42,000 A rms symmetrical
  - BRX—65,000 A rms symmetrical
- **Handles**—trip-free with ON-TRIPPED-OFF positions. Reset past OFF is required to latch breaker contacts after tripping
- **Terminals**—standard lugs (wire connectors) suitable for copper or aluminum wire

#### Standards and Certifications

- Complies with UL Standard 489. Breakers are listed under UL File #E7819



Product Selection



Type BR 120/240 V Tenant Main Circuit Breakers

Description	Number of Poles	Main Tenant Circuit Breaker Ampere Rating	10 kAIC Catalog Number	22 kAIC Catalog Number	22 kAIC ① Catalog Number	42 kAIC Catalog Number	65 kAIC Catalog Number	100 kAIC Catalog Number
<b>Plug-On Type</b>								
Plug-on type circuit breakers used with 1MP, 1MM, and 3MM 125 A modular metering stacks	2	60	BR260	BRH260	BRHX260	BRHH260	BRX260	—
	2	70	BR270	BRH270	BRHX270	BRHH270	BRX270	—
	2	80	BR280	BRH280	BRHX280	BRHH280	BRX280	—
<b>Wire Sizes</b>								
#8–1/0 Cu/Al—for 60–100 A	2	90	BR290	BRH290	BRHX290	BRHH290	BRX290	—
Only exception is BRX, which is #8–2/0 Cu/Al	2	100	BR2100	BRH2100	BRHX2100	BRHH2100	BRX2100	—
#8–2/0 Cu/Al—for 125 A	2	110	BR2110	BRH2110	BRHX2110	BRHH2110	BRX2110	—
	2	125	BR2125	BRH2125	BRHX2125	BRHH2125	BRX2125	—

Field Installable Lug Kits for 1MM and 3MM Tenant Main Circuit Breakers  
(For use with Residential Meter Stacks to account for bigger wire sizes)

BR40LUG



Description	Catalog Number
4/0 Lug adapter—accommodates 3/0–4/0	BR40LUG

BR40NEU



4/0 Neutral bar adapter—accommodates #1–4/0	BR40NEU
---	---------

Up-sized ground bar kit	1MMGBK
Two-pole 300 kcmil with terminal shield	2TA225CVK
Three-pole 300 kcmil with terminal shield	3TA225CVK
Replacement mounting hardware kit for 200 A 1MP, 1MM and 3MM units	1MMCBK

Wire Sizes—Neutral and Ground Lugs

Description	Wire Size, Al/Cu	Catalog Number
Neutral—125 A meter pack	#6–2/0	—
Neutral—200 A meter pack	#1/0–300 kcmil	—
Equipment ground bar—125 A meter pack	#14–#2	—
Equipment ground bar—200 A meter pack	#14–2/0	—
Optional ground bar	#6–2/0	1MMGBK

BR40LUG Compatibility Chart

Type	60 A	70 A	80 A	90 A	100 A	110 A	125 A
BR	—	—	—	—	—	BR2110	BR2125
BRH	—	—	—	—	—	BRH2110	BRH2125
BRHX	—	—	—	—	—	BRHX2110	BRHX2125
BRHH	—	—	—	—	—	BRHH2110	BRHH2125
BRX	BRX260	BRX270	BRX280	BRX290	BRX2100	BRX2110	BRX2125

Other Notes for Lug Kits

**Notes:** The lug adapter kit can be used in 1MM and 3MM 3- through 6-socket 125 A modular metering stacks. Only intended for use in bottom- and rear-feed applications. Four adapters can be used per meter stack.

Notes

- ① Only to be used in 3-tier solution requiring a 65 kAIC rated main breaker (up to 2000 A) upstream.
- ① This kit comes with three pads for two lines and neutral. Each pad will accept one or two crimp lugs. Cannot be used on 1MP2122R, RL, RC and RLB EUSERC underground termination.
- ② This lug is not UL listed.

Each stack includes a neutral and ground bar. If an extra ground bar is needed, order 1MMGBK.

Type CCV Tenant Main Circuit Breaker



### Type CCV 120/240 V

#### Product Overview

Eaton offers Type CCV (10 and 22 kAIC) and Type CV (42, 65 and 100 kAIC) family of circuit breakers as the primary tenant main breakers used in most group metering applications.

#### Product Description

Eaton’s residential products Type CCV circuit breaker is available in two-pole configurations from 100 A to 225 A in 10 and 22 kAIC ratings.

#### Features

- **Ratings**—120/240 Vac, two-pole, through 225 continuous amperes, calibrated at 40 °C
- **Tripping characteristics**—thermal-magnetic trip, calibrated and sealed after assembly. Indirectly heated thermal tripping bimetal elements
- **Interrupting capacity** at 120/240 Vac. Type CCV—10 kAIC rms symmetrical. Type CCVH—25 kAIC rms symmetrical

#### Standards and Certifications

- Complies with UL Standard 489. Breakers are listed under UL File #E7819



### Contents

#### Description

	<i>Page</i>
Systems for Residential and Commercial Applications . . . . .	<b>V1-T4-68</b>
Meter Packs . . . . .	<b>V1-T4-76</b>
Meter Packs—Tenant Circuit Breakers . . . . .	<b>V1-T4-88</b>
Main Service Modules . . . . .	<b>V1-T4-89</b>
Residential Meter Stacks . . . . .	<b>V1-T4-108</b>
Commercial Meter Stack Modules . . . . .	<b>V1-T4-123</b>
35MM, 37MM, 35SS and 37SS Tenant Main Circuit Breakers . . . . .	<b>V1-T4-130</b>
Phase Balanced Stack . . . . .	<b>V1-T4-132</b>
Group Metering Inline Current Transformer Cabinets . . . . .	<b>V1-T4-133</b>
Surge Metering . . . . .	<b>V1-T4-134</b>
Group Metering Accessories . . . . .	<b>V1-T4-135</b>

### Product Selection

#### Type CCV 120/240 V Tenant Main Circuit Breaker

Ampere Rating	Two-Pole Breaker		
	Wire Size Range, Al/Cu		
		10 kAIC	25 kAIC
60	#2–300 kcmil	<b>CCV2060X</b>	<b>CCVH2060X</b>
70		<b>CCV2070X</b>	<b>CCVH2070X</b>
80		<b>CCV2080X</b>	<b>CCVH2080X</b>
90		<b>CCV2090X</b>	<b>CCVH2090X</b>
100		<b>CCV2100X</b>	<b>CCVH2100X</b>
125		<b>CCV2125X</b>	<b>CCVH2125X</b>
150		<b>CCV2150X</b>	<b>CCVH2150X</b>
175		<b>CCV2175X</b>	<b>CCVH2175X</b>
200		<b>CCV2200X</b>	<b>CCVH2200X</b>
225		<b>CCV2225X</b>	<b>CCVH2225X</b>

#### Modification Codes

- X—load side terminals only

Type CV Tenant Main Circuit Breaker



**Type CV 120/240 V**

**Product Overview**

Eaton offers Type CCV (10 and 22 kAIC) and Type CV (42, 65 and 100 kAIC) family of circuit breakers as the primary tenant main breakers used in most group metering applications.

**Product Description**

Eaton’s residential products Type CV molded-case circuit breaker is available in two- and three-pole configurations from 60 A to 225 A in 42, 65 and 100 kAIC ratings.

**Contents**

<i>Description</i>	<i>Page</i>
Systems for Residential and Commercial Applications . . . . .	<b>V1-T4-68</b>
Meter Packs . . . . .	<b>V1-T4-76</b>
Meter Packs—Tenant Circuit Breakers . . . . .	<b>V1-T4-88</b>
Main Service Modules . . . . .	<b>V1-T4-89</b>
Residential Meter Stacks . . . . .	<b>V1-T4-108</b>
Commercial Meter Stack Modules . . . . .	<b>V1-T4-123</b>
35MM, 37MM, 35SS and 37SS Tenant Main Circuit Breakers . . . . .	<b>V1-T4-130</b>
Phase Balanced Stack . . . . .	<b>V1-T4-132</b>
Group Metering Inline Current Transformer Cabinets . . . . .	<b>V1-T4-133</b>
Surge Metering . . . . .	<b>V1-T4-134</b>
Group Metering Accessories . . . . .	<b>V1-T4-135</b>

**Features**

- **Ratings**—120/240 Vac, two- and three-pole, through 225 continuous amperes, calibrated at 40 °C
- **Tripping characteristics**—thermal-magnetic trip, calibrated and sealed after assembly. Indirectly heated thermal tripping bimetal elements; includes push-to-test button for routine preventive maintenance
- **Interrupting capacity** at 120/240 Vac
  - Type CVS—42,000 A rms symmetrical
  - Type CV—65,000 A rms symmetrical
  - Type CVH—100,000 A rms symmetrical
- **Handles**—trip-free with ON-TRIPPED-OFF positions. Reset past OFF is required to latch breaker contacts after tripping
- **Terminals**—standard lugs (wire connectors) suitable for copper or aluminum wire

**Standards and Certifications**

- Complies with UL Standard 489. Breakers are listed under UL File #E7819



#### Product Selection

##### Type CV Two-Pole Tenant Main Circuit Breakers

Number of Poles	Main Tenant Circuit Breaker Ampere Rating	Wire Size Range, Al/Cu	42 kAIC Catalog Number	65 kAIC Catalog Number	100 kAIC Catalog Number
2	60	#6-4/0	CVS2060XMM	CV2060XMM	CVH2060XMM
	70		CVS2070XMM	CV2070XMM	CVH2070XMM
	80		CVS2080XMM	CV2080XMM	CVH2080XMM
	90		CVS2090XMM	CV2090XMM	CVH2090XMM
	100		CVS2100XMM	CV2100XMM	CVH2100XMM
	125		CVS2125XMM	CV2125XMM	CVH2125XMM
	150		CVS2150XMM	CV2150XMM	CVH2150XMM
	175		CVS2175XMM	CV2175XMM	CVH2175XMM
	200		CVS2200XMM	CV2200XMM	CVH2200XMM
	225		CVS2225XMM	CV2225XMM	CVH2225XMM

##### Type CV Three-Pole Tenant Main Circuit Breakers

Number of Poles	Main Tenant Circuit Breaker Ampere Rating	Wire Size Range, Al/Cu	42 kAIC Catalog Number	65 kAIC Catalog Number	100 kAIC Catalog Number
3	60	#6-4/0	CVS3060X	CV3060X	CVH3060X
	70		CVS3070X	CV3070X	CVH3070X
	80		CVS3080X	CV3080X	CVH3080X
	90		CVS3090X	CV3090X	CVH3090X
	100		CVS3100X	CV3100X	CVH3100X
	125		CVS3125X	CV3125X	CVH3125X
	150		CVS3150X	CV3150X	CVH3150X
	175		CVS3175X	CV3175X	CVH3175X
	200		CVS3200X	CV3200X	CVH3200X
	225		CVS3225X	CV3225X	CVH3225X

Commercial Meter Stack Modules (35MM, 37MM, 35SS and 37SS)



35MM, 37MM, 35SS and 37SS

### Contents

<i>Description</i>	<i>Page</i>
Systems for Residential and Commercial Applications . . . . .	<b>V1-T4-68</b>
Meter Packs . . . . .	<b>V1-T4-76</b>
Meter Packs—Tenant Circuit Breakers . . . . .	<b>V1-T4-88</b>
Main Service Modules . . . . .	<b>V1-T4-89</b>
Residential Meter Stacks . . . . .	<b>V1-T4-108</b>
Commercial Meter Stack Modules	
Catalog Number Selection . . . . .	<b>V1-T4-124</b>
Product Selection . . . . .	<b>V1-T4-125</b>
Dimensions and Knockouts . . . . .	<b>V1-T4-128</b>
35MM, 37MM, 35SS and 37SS Tenant Main Circuit Breakers . . . . .	<b>V1-T4-130</b>
Phase Balanced Stack . . . . .	<b>V1-T4-132</b>
Group Metering Inline Current Transformer Cabinets . . . . .	<b>V1-T4-133</b>
Surge Metering . . . . .	<b>V1-T4-134</b>
Group Metering Accessories . . . . .	<b>V1-T4-135</b>

### Commercial Meter Stacks—Tenant Main Circuit Breakers

#### Product Description

- Heavy-duty lever bypass socket design
- Single-phase or three-phase designs (35 = single-phase, 37 = three-phase)
- Provision for two-pole or three-pole main tenant breakers
- Phase balance kits are included with three-high and four-high modules

#### Features, Benefits and Functions

##### A. End Walls

The top cap is removable and does not contain knockouts, so contractors can position and punch holes where they need them. There are numerous KOs in the back and bottom for flexibility.

##### B. Ground Bars

The factory-installed equipment ground bars are provided in both the top and bottom gutters.

##### C. Meter Socket

The 5-jaw meter socket and 7-jaw meter socket includes a built-in manual bypass and jaw release. The ground wire is factory connected in both 35MM and 37MM modules.

##### D. Separate Wireway Cover

If work on the breakers or cables is necessary, it can be accomplished without disturbing the meters or meter covers, thanks to a separate cover that allows easy access to the module's main tenant breaker and wireway section. (Not shown.)

##### E. Barrier

A solid metal barrier separates the meter socket section from the tenant breaker in the wireway section. The un-metered vertical bus is enclosed to guard against power theft.

##### F. Neutral Assembly

Located in the wireway of each module, the assembly permits convenient termination of the neutral conductors.

##### G. Enclosed Horizontal Bus

Non-removable metal barrier encloses 1200 A horizontal bus when passing through the tenant breaker section for added security.

##### H. Tenant Breaker Range

All modules accept 15–225 A bolt-on breakers in various AIC ratings. The CHH\_X breaker carries a UL listed series rating of 100,000 A, which allows you to use standard 10 kAIC breakers in downstream loadcenters and panelboards by Eaton.

##### I. Indoor/Outdoor Construction

Raintight caps, meter covers and lockable raintight tenant breaker covers make it convenient for you to use any of our modules on either NEMA 1 or NEMA 3R applications.

##### J. Mounting Rail

Rear mounting rail and wall hanger speed and simplify installation. (Mounting rail not shown.)

##### K. Nameplate and Ratings

The nameplate gives you full rating data: 208Y/120, three-phase, four-wire; 240/120, three-phase, four-wire delta (high leg on B-phase); and 240/120 single-phase. (Not shown.)

##### L. Mains and Modules

Slip together quickly, smoothly with front-accessible captive bolts securing the juncture without removing socket interiors or bus access plate. Main bus joint bolts torque to 25 foot pounds.



# 4.3

## Metering Products

### Group Metering

4

#### 37MM Meter Stack Module

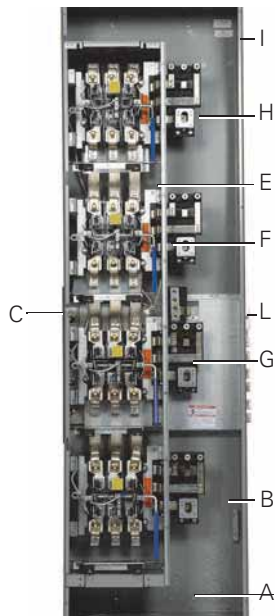

- Eaton's 35MM and 37MM modular metering stacks contain meter sockets with built-in manual bypass and jaw release (Non-EUSERC areas)
- Eaton's 35SS and 37SS stacks use meter sockets with test bypass feature (meets EUSERC electrical requirements)
- All commercial modular metering stacks contain four horizontal cross buses
- Mechanically and electrically built to bolt-up with main service modules and residential modular metering stacks

#### Catalog Number Selection

##### Commercial Meter Stack Modules

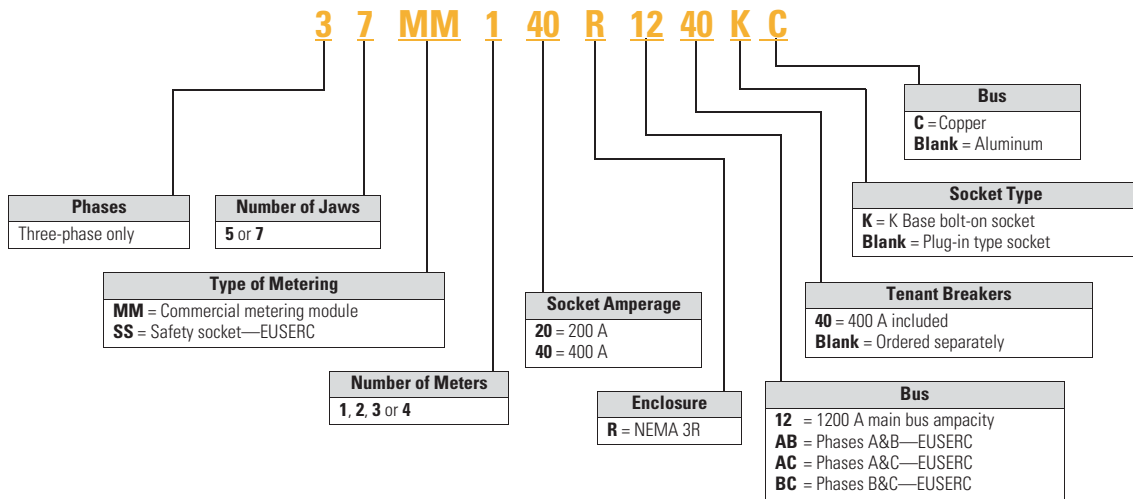

#### When Ordering:

1. Determine catalog number of Main Service Module.
2. Determine catalog number of Meter Stack (Residential or Commercial).
3. Find quantity and catalog numbers for tenant circuit breakers (found on **Page V1-T4-125**). Order one breaker per socket.
4. If any accessories are needed, order from **Pages V1-T4-136** and **V1-T4-137**.

**Product Selection**

**35MM**

- Each socket is a 5 terminal block with lever bypass and jaw release
- Ringless covers
- Provision for two-pole main tenant breakers (circuit breakers not included). For circuit breaker catalog numbers, refer to **Page V1-T4-125**
- Phase balancing kits are included with three-high and four-high modules. Each individual socket can be phase balanced in the field to the desired lines (A-B, B-C or A-C). Comes from factory as A-B
- Indoor/outdoor construction
- Main tenant feeders can exit top, bottom or back
- If being used in outdoor application and exiting the top, mount Myer type hubs on rainproof cap
- Short-circuit ratings up to 100 A rms symmetrical depending upon the kAIC rating of installed main tenant circuit breakers and main device
- Non-EUSERC areas

**35MM—Single-Phase Commercial Meter Stack Modules (Three-Phase In, Single-Phase Out)**

System Voltage	Ampere Rating Per Meter Socket	Number of Meter Sockets	Horizontal Bus Ampacity/ Material	Number of Jaws Per Meter Socket	Main Tenant Breaker Type (Page V1-T4-125) ①	Catalog Number
120/240 V, single-phase, three-wire systems and 208Y/120 V network metering (Not suitable for use on three-phase, four-wire delta systems)	225	1	1200 Al	5	Bolt-on type EHD2_ CCV2_X CCVH2_X CVS2_XMM CV2_XMM CVH2_XMM	<b>35MM120R12</b>
		1	1200 Cu	5		<b>35MM120R12C</b>
		2	1200 Al	5		<b>35MM220R12</b>
		2	1200 Cu	5		<b>35MM220R12C</b>
		3	1200 Al	5		<b>35MM320R12</b>
		3	1200 Cu	5		<b>35MM320R12C</b>
		4	1200 Al	5		<b>35MM420R12</b>
		4	1200 Cu	5		<b>35MM420R12C</b>
	400	1	1200 Al	5	400 A K-Frame included	<b>35MM140R1240</b> ②
		1	1200 Cu	5		<b>35MM140R1240C</b> ②
	400	1	1200 Al	5	400 A K-Frame included	<b>35MM140HR1240</b> ③
		1	1200 Cu	5		<b>35MM140HR1240C</b> ③
	400	2	1200 Al	5	400 A K-Frame included	<b>35MM240R1240</b>
		2	1200 Cu	5		<b>35MM240R1240C</b>
	400 continuous	1	1200 Cu	5	400 A L-Frame included	<b>35MM140R1240K</b>
	400 continuous	1	1200 Cu	5	400 A L-Frame included	<b>35MM140HR1240KC</b> ④

**Notes**

- ① Retrofit tenant circuit breaker mounting kit (**37MMRCBK**) for installation of Type EHD and CV breakers. Needed only for stacks manufactured prior to February 2013. Order one kit per breaker.
- ② Unit is bottom exit only.
- ③ Rated at 100 kAIC.
- ④ Rated at 35 kAIC.

#### 37MM

- Each socket is a 7 terminal block with lever bypass and jaw release
- Ringless covers
- Provision for three-pole main tenant breakers (circuit breakers not included). For circuit breaker catalog numbers, refer to **Page V1-T4-125**
- Indoor/outdoor construction
- Main tenant breakers can exit top, bottom or back
- If being used in outdoor application and exiting the top, mount Myer type hubs on rainproof cap
- Short-circuit ratings up to 100 A rms symmetrical depending upon the kAIC rating of installed main tenant circuit breakers and main device
- Non-EUSERC areas

#### 37MM—Three-Phase Commercial Meter Stack Modules (Three-Phase In, Three-Phase Out)

System Voltage	Ampere Rating Per Meter Socket	Number of Meter Sockets	Horizontal Bus Ampacity/Material	Number of Jaws Per Meter Socket ①	Main Tenant Breaker Type ② (Page V1-T4-125)	Catalog Number
208Y/120 V, three-phase, four-wire 240/120 V, three-phase, four-wire delta (B-phase is high leg)	225	1	1200 Al	7	Bolt-on type EHD3_ CC3_X CVS3_X CV3_X CVH3_X	<b>37MM120R12</b>
		1	1200 Cu	7		<b>37MM120R12C</b>
		2	1200 Al	7		<b>37MM220R12</b>
		2	1200 Cu	7		<b>37MM220R12C</b>
		3	1200 Al	7		<b>37MM320R12</b>
		3	1200 Cu	7		<b>37MM320R12C</b>
		4	1200 Al	7		<b>37MM420R12</b>
		4	1200 Cu	7		<b>37MM420R12C</b>
	400	1	1200 Al	7	Bolt-on type EHD3_ CC3_X CVS3_X CV3_X CVH3_X	<b>37MM140R12</b> ③
		1	1200 Cu	7		<b>37MM140R12C</b> ③
	400	1	1200 Al	7	400 A K-Frame included	<b>37MM140R1240</b> ④
		1	1200 Cu	7		<b>37MM140R1240C</b> ④
	400	1	1200 Al	7	400 A K-Frame included	<b>37MM140HR1240</b> ⑤
		1	1200 Cu	7		<b>37MM140HR1240C</b> ⑤
400	2	1200 Al	7	400 A K-Frame included	<b>37MM240R1240</b>	
	2	1200 Cu	7		<b>37MM240R1240C</b>	
400 continuous	1	1200 Cu	7	400 A L-Frame included	<b>37MM140R1240KC</b> ⑥	
400 continuous	1	1200 Cu	7	400 A L-Frame included	<b>37MM140HR1240KC</b> ⑦	

#### Notes

- ① If a socket in a 37MM meter stack module needs to be single-phase, order **37MM1CK**. This will convert the three-phase socket to single-phase.
- ② Retrofit tenant circuit breaker mounting kit (**37MMRCBK**) for installation of Type EHD and CV breakers. Needed only for stacks manufactured prior to February 2013. Order one kit per breaker.
- ③ 320 A continuous rated socket with provisions for two main tenant breakers.
- ④ Unit is bottom exit only.
- ⑤ Rated at 100 kAIC.
- ⑥ Rated at 25 kAIC.
- ⑦ Rated at 35 kAIC.

**35SS**

- Sockets include EUSERC required test-bypass-disconnect feature
- Ring type covers
- Single-phase units have provisions for two-pole main tenant breakers
- When applying 35SS (single-phase) stacks on 208Y/120 V, three-phase, four-wire and 240/120 V, three-phase, four-wire delta systems, refer to suffixes for proper phase balancing. Each meter stack module is phase balanced at the plant (A-B, B-C or A-C) and cannot be field modified
- Indoor/outdoor construction
- Main tenant breakers can exit top, bottom or back. If being used in outdoor application and exiting the top, mount Myer type hubs on rainproof cap
- Short-circuit ratings up to 100 A rms symmetrical depending upon the kAIC rating of installed main tenant circuit breakers and main device

**35SS**

**35SS—Three-Phase Commercial Meter Stack Modules** ①



System Voltage	Ampere Rating Per Meter Socket	Number of Meter Sockets	Horizontal Bus Ampacity/Material	Number of Jaws Per Meter Socket	Main Tenant Breaker Type ② (Page V1-T4-125)	Catalog Number
120/240 V, single-phase, three-wire systems and 208Y/120 V network metering (Not suitable for use on three-phase, four-wire delta systems)	225	1	1200 Al	5	Bolt-on type	<b>35SS120RAB</b> ③
			1200 Cu	5	EHD2_	<b>35SS120RABC</b> ③
		1200 Al	5	CCV2_X	<b>35SS120RAC</b> ③	
		1200 Cu	5	CCVH2_X	<b>35SS120RACC</b> ③	
		1200 Al	5	CVS2_X	<b>35SS120RBC</b> ③	
		1200 Cu	5	CV2_X	<b>35SS120RBCC</b> ③	
	2	1200 Al	5	<b>35SS220RAB</b> ③		
			5	<b>35SS220RABC</b> ③		
		1200 Al	5	<b>35SS220RAC</b> ③		
		1200 Cu	5	<b>35SS220RACC</b> ③		
		1200 Al	5	<b>35SS220RBC</b> ③		
		1200 Cu	5	<b>35SS220RBCC</b> ③		
	3	1200 Al	5	<b>35SS320RAB</b> ③		
			5	<b>35SS320RABC</b> ③		
		1200 Al	5	<b>35SS320RAC</b> ③		
		1200 Cu	5	<b>35SS320RACC</b> ③		
		1200 Al	5	<b>35SS320RBC</b> ③		
		1200 Cu	5	<b>35SS320RBCC</b> ③		

**37SS**

- Sockets include EUSERC required test-bypass-disconnect feature
- Ring type covers
- Three-phase units have provisions for three-pole main tenant breaker
- Aluminum horizontal bus supplied as standard

**37SS—Three-Phase Commercial Meter Stack Modules** ①

System Voltage	Ampere Rating Per Meter Socket	Number of Meter Sockets	Horizontal Bus Ampacity/Material	Number of Jaws Per Meter Socket	Main Tenant Breaker Type ② (Page V1-T4-125)	Catalog Number
208Y/120 V, three-phase, four-wire 240/120 V, three-phase, four-wire delta (B-phase is high leg)	225	1	1200 Al	7	Bolt-on type	<b>37SS120R</b>
			1200 Cu	7	EHD3_	<b>37SS120RC</b>
	1200 Al	7	CC3_X	<b>37SS220R</b>		
	1200 Cu	7	CVS3_X	<b>37SS220RC</b>		
	1200 Al	7	CV3_X	<b>37SS320R</b>		
	1200 Cu	7	CVH3_X	<b>37SS320RC</b>		

**Notes**

- ① Reference drawing EUSERC DWG-304 for 100 A; Reference drawing EUSERC DWG-305 for 200 A.
- ② Retrofit tenant circuit breaker mounting kit (**37MMRCBK**) for installation of Type EHD and CV breakers. Needed only for stacks manufactured prior to February 2013. Order one kit per breaker.
- ③ Last two digits of catalog number indicate phase balancing (AB indicates all sockets in this stack are connected to phases A and B only).

# 4.3

## Metering Products

### Group Metering

#### Dimensions and Knockouts

Approximate Dimensions in Inches (mm)

#### Commercial Stacks (35MM and 37MM)

#### 35MM and 37MM

4

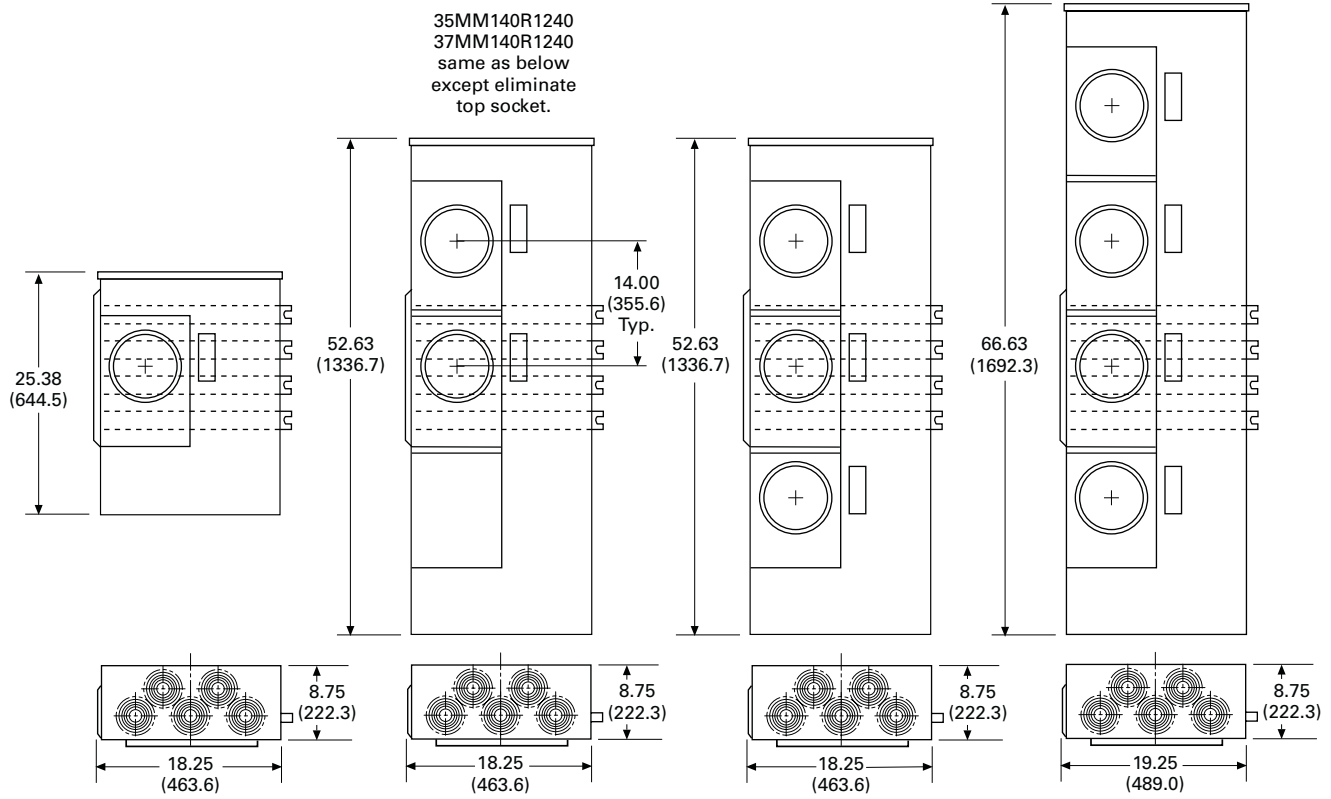

Approximate Dimensions in Inches (mm)

### Commercial Stacks (35SS and 37SS)

#### 35SS and 37SS

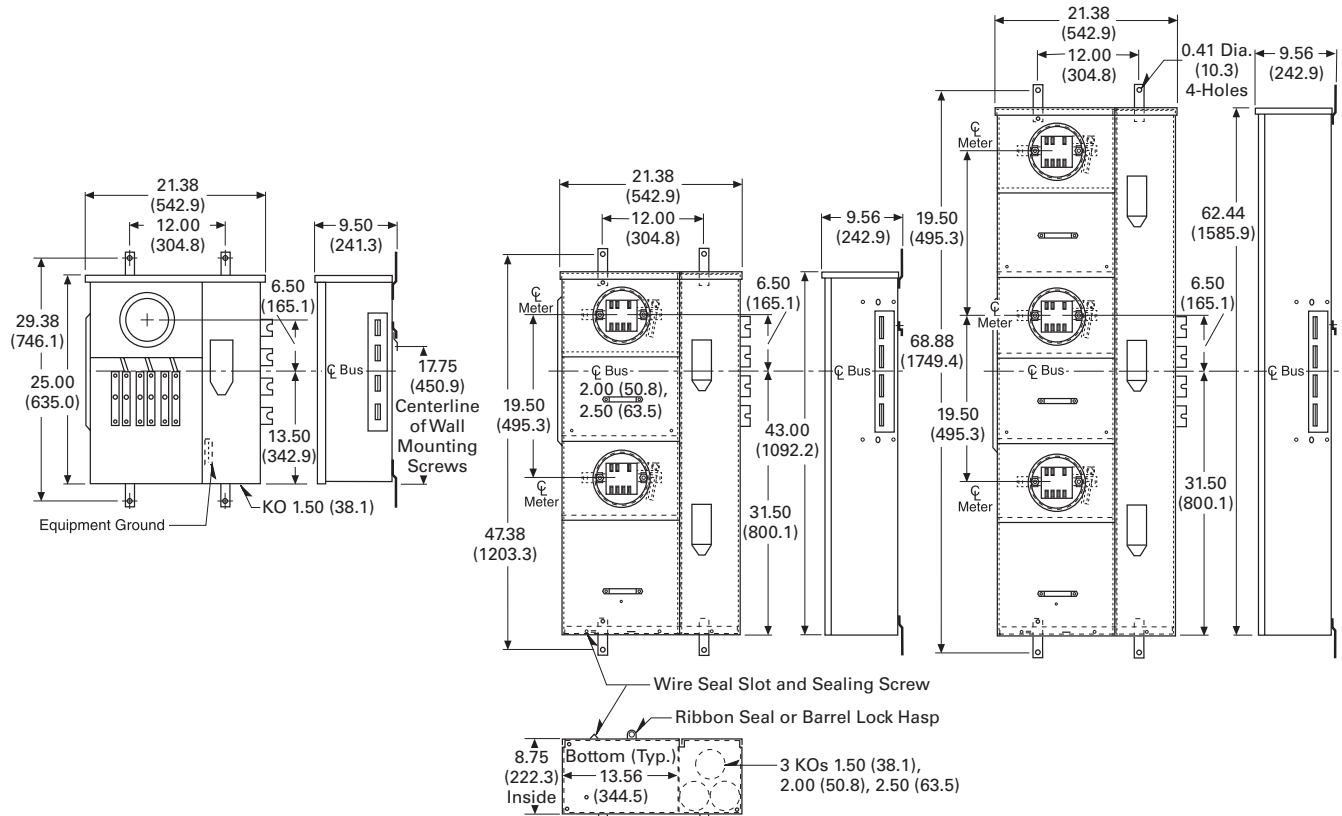

#### 35MM, 37MM, 35SS and 37SS Main Tenant Circuit Breakers



CV2200/CV3200

#### 35MM, 37MM, 35SS and 37SS Tenant Main Circuit Breakers

##### Product Description

- The following breakers are to be used on 35MM, 37MM, 35SS and 37SS modular metering stacks
- Series rating information available on **Page V1-T4-73**
- Two-pole breakers are 120/240 Vac, field installed
- Three-pole breakers are 208Y/120 Vac, field installed

#### Contents

##### Description

	<i>Page</i>
Systems for Residential and Commercial Applications . . . . .	<b>V1-T4-68</b>
Meter Packs . . . . .	<b>V1-T4-76</b>
Meter Packs—Tenant Circuit Breakers . . . . .	<b>V1-T4-88</b>
Main Service Modules . . . . .	<b>V1-T4-89</b>
Residential Meter Stacks . . . . .	<b>V1-T4-108</b>
Commercial Meter Stack Modules . . . . .	<b>V1-T4-123</b>
35MM, 37MM, 35SS and 37SS Tenant Main Circuit Breakers	
Product Selection . . . . .	<b>V1-T4-131</b>
Phase Balanced Stack . . . . .	<b>V1-T4-132</b>
Group Metering Inline Current Transformer Cabinets . . . . .	<b>V1-T4-133</b>
Surge Metering . . . . .	<b>V1-T4-134</b>
Group Metering Accessories . . . . .	<b>V1-T4-135</b>

**Product Selection**

**35MM, 37MM, 35SS and 37SS Main Tenant Circuit Breakers**

Description	Number of Poles	Main Tenant Circuit Breaker Ampere Rating	10 kAIC	25 kAIC	42 kAIC	65 kAIC	100 kAIC
			Catalog Number	Catalog Number <sup>①②</sup>	Catalog Number <sup>①②</sup>	Catalog Number <sup>①②</sup>	Catalog Number <sup>①②</sup>
<b>Bolt-On Type</b>							
Bolt-on type circuit breakers used with 35MM and 35SS (single-phase modular metering stacks) <sup>③④</sup>	2	60	CCV2060X	CCVH2060X	CVS2060XMM	CV2060XMM	CVH2060XMM
	2	70	CCV2070X	CCVH2070X	CVS2070XMM	CV2070XMM	CVH2070XMM
	2	80	CCV2080X	CCVH2080X	CVS2080XMM	CV2080XMM	CVH2080XMM
	2	90	CCV2090X	CCVH2090X	CVS2090XMM	CV2090XMM	CVH2090XMM
	2	100	CCV2100X	CCVH2100X	CVS2100XMM	CV2100XMM	CVH2100XMM
	2	125	CCV2125X	CCVH2125X	CVS2125XMM	CV2125XMM	CVH2125XMM
	2	150	CCV2150X	CCVH2150X	CVS2150XMM	CV2150XMM	CVH2150XMM
	2	175	CCV2175X	CCVH2175X	CVS2175XMM	CV2175XMM	CVH2175XMM
	2	200	CCV2200X	CCVH2200X	CVS2200XMM	CV2200XMM	CVH2200XMM
	2	225	CCV2225X	CCVH2225X	CVS2225XMM	CV2225XMM	CVH2225XMM
<b>Bolt-On Type</b>							
Bolt-on type circuit breakers used with 37MM and 37SS (three-phase modular metering stacks) <sup>③④</sup>	3	60	EHD3060	CVS3060X	CVS3060X	CV3060X	CVH3060X
	3	70	EHD3070	CVS3070X	CVS3070X	CV3070X	CVH3070X
	3	80	EHD3080	CVS3080X	CVS3080X	CV3080X	CVH3080X
	3	90	EHD3090	CVS3090X	CVS3090X	CV3090X	CVH3090X
	3	100	CC3100X	CVS3100X	CVS3100X	CV3100X	CVH3100X
	3	125	CC3125X	CVS3125X	CVS3125X	CV3125X	CVH3125X
	3	150	CC3150X	CVS3150X	CVS3150X	CV3150X	CVH3150X
	3	175	CC3175X	CVS3175X	CVS3175X	CV3175X	CVH3175X
	3	200	CC3200X	CVS3200X	CVS3200X	CV3200X	CVH3200X
	3	225	CC3225X	CVS3225X	CVS3225X	CV3225X	CVH3225X

**Notes**

- ① #6–4/0 kcmil wire size range for CVS, CV and CVH tenant main circuit breakers. If #2–300 kcmil is needed, order **2TA225CVK** (two-pole) **3TA225CVK** (three-pole). One kit is needed per breaker.
- ② “MM” suffix provides mounting hardware needed for 1MP, 1MM and 3MM modular metering stacks only. Mounting hardware is not needed for use in 35MM and 35SS modular metering stacks, but is included as standard with breakers.
- ③ Retrofit tenant circuit breaker mounting kit (**37MMRCBK**) for installation of Type EHD and CV breakers. Needed only for stacks manufactured prior to February 2013. Order one kit per breaker.
- ④ Type EHD main tenant circuit breakers are also available from 15 to 50 A.



**Phase Balanced Stack**

### Phase Balanced Stack

#### Product Description

Eaton’s Phase Balanced Stack allows for a complete phase balanced metering line-up using fewer stacks. With today’s electrical rooms becoming smaller, the need is greater than ever to offer space-saving metering products while providing a fully phase balanced system. The new phase balanced stack is the answer.

Today, achieving a phase balanced system when connected to a 208Y/120 Vac three-phase, four-wire system may require one or two additional 3MM meter modules. Standard 3MM meter stacks come factory connected to phases A and B. The new phase balanced stacks connect the two bottom meters to phases B and C and the top two or three meters to phases A and C. Using these new stacks with the AB phased 3MM metering, phase balancing is accomplished, and more compact than before.

#### Features

- Available in four- and five-high configurations at 125 A
- 200 A stacks available
- Available with 800 A aluminum bus and 1200 A copper bus
- Ring, ringless, ringless with horn bypass available
- Outdoor enclosure
- Dimensions same as existing 125 A, three-phase meter stacks

### Contents

<i>Description</i>	<i>Page</i>
Systems for Residential and Commercial Applications . . . . .	<b>V1-T4-68</b>
Meter Packs . . . . .	<b>V1-T4-76</b>
Meter Packs—Tenant Circuit Breakers . . . . .	<b>V1-T4-88</b>
Main Service Modules . . . . .	<b>V1-T4-89</b>
Residential Meter Stacks . . . . .	<b>V1-T4-108</b>
Commercial Meter Stack Modules . . . . .	<b>V1-T4-123</b>
35MM, 37MM, 35SS and 37SS Tenant Main Circuit Breakers . . . . .	<b>V1-T4-130</b>
Phase Balanced Stack . . . . .	<b>V1-T4-132</b>
Group Metering Inline Current Transformer Cabinets . . . . .	<b>V1-T4-133</b>
Surge Metering . . . . .	<b>V1-T4-134</b>
Group Metering Accessories . . . . .	<b>V1-T4-135</b>

#### Product Selection

##### Ordering Information

- Check with local utility for height restrictions
- Items loaded in VISTA
- If you have questions, please contact the Technical Resource Center 1-800-356-1243, option 3

#### Phase Balanced Stack

Amperes Per Meter Socket	Bus Ampacity	Meter Socket Cover	Catalog Number
125	800	Ring	<b>3MM412RACBC</b>
125	800	Ring	<b>3MM512RACBC</b>
125	800	Ringless	<b>3MM412RRLACBC</b>
125	800	Ringless	<b>3MM512RRLACBC</b>
125	800	Ringless horn bypass	<b>3MM412RRLBACBC</b>
125	800	Ringless horn bypass	<b>3MM512RRLBACBC</b>
125	1200	Ring	<b>3MM412R2ACBC</b>
125	1200	Ring	<b>3MM512R2ACBC</b>
125	1200	Ringless	<b>3MM412R2RLACBC</b>
125	1200	Ringless	<b>3MM512R2RLACBC</b>
125	1200	Ringless horn bypass	<b>3MM412R2RLBACBC</b>
125	1200	Ringless horn bypass	<b>3MM512R2RLBACBC</b>

**Note:** Local codes and utility requirements still apply. The phase balance stacks are not suitable for changing in the field.

Group Metering Inline Current Transformer Cabinets

Group Metering Inline Current Transformer Cabinets

Product Description

Eaton’s group metering inline current transformer (CT) cabinets are used when utilities require the use of current transformers to meter large services. These products are compatible with Eaton’s group metering offering for both single- and three-phase applications with tenant metering requirements greater than 400 A.

Features, Benefits and Functions

- Replaces separate termination box in installation to save wall space, labor and material for the contractor
- Compatible for utility-provided current transformers to be bolted in place, increasing flexibility to both the customer and utility
- Padlockable hinged doors restrict access to fuses or current transformers to ensure safety and security
- Available for pullout or fusible switch disconnect to accommodate the user’s preference
- Offered in three-phase in/ three-phase out, three-phase in / single-phase out, and single-phase in/ single-phase out to complete a full product line offering

Contents

<i>Description</i>	<i>Page</i>
Systems for Residential and Commercial Applications . . . . .	<b>V1-T4-68</b>
Meter Packs . . . . .	<b>V1-T4-76</b>
Meter Packs—Tenant Circuit Breakers . . . . .	<b>V1-T4-88</b>
Main Service Modules . . . . .	<b>V1-T4-89</b>
Residential Meter Stacks . . . . .	<b>V1-T4-108</b>
Commercial Meter Stack Modules . . . . .	<b>V1-T4-123</b>
35MM, 37MM, 35SS and 37SS Tenant Main Circuit Breakers . . . . .	<b>V1-T4-130</b>
Phase Balanced Stack . . . . .	<b>V1-T4-132</b>
Group Metering Inline Current Transformer Cabinets . . . . .	<b>V1-T4-133</b>
Surge Metering . . . . .	<b>V1-T4-134</b>
Group Metering Accessories . . . . .	<b>V1-T4-135</b>

Product Selection

Group Metering Inline Current Transformer Cabinets

Ampere Rating	Pullout or Switch	Phase	Catalog Number
400	2 Pullouts	Single-phase in / single-phase out	CTAP3244NCM8CH11
400	2 Pullouts	Three-phase in / single-phase out	CTAP3244NCM8CH31
400	1 Pullout	Single-phase in / single-phase out	CTAP325NCM8CH11
400	1 Pullout	Three-phase in / single-phase out	CTAP325NCM8CH31
400	2 Pullouts	Three-phase in / three-phase out	CTAP4244NCM8CH
400	1 Pullout	Three-phase in / three-phase out	CTAP425NCM8CH
400	Switch	Single-phase in / single-phase out	CTAT325NCM8CH11
400	Switch	Three-phase in / single-phase out	CTAT325NCM8CH31
600	Switch	Single-phase in / single-phase out	CTAT326NCM8CH11
600	Switch	Three-phase in / single-phase out	CTAT326NCM8CH31
800	Switch	Single-phase in / single-phase out	CTAT327NCM8CH11
800	Switch	Three-phase in / single-phase out	CTAT327NCM8CH31
400	Switch	Three-phase in / three-phase out	CTAT425NCM8CH
600	Switch	Three-phase in / three-phase out	CTAT426NCM8CH
800	Switch	Three-phase in / three-phase out	CTAT427NCM8CH

Accessories

Group Metering Inline Current Transformer Cabinets

Description	Catalog Number
Wire harness (6 ft) per COMED requirements	9659
400 A C/T link and support assembly	CTL054550
600 A C/T link and support assembly	CTL054552
800 A C/T link and support assembly	CTL054554

Dimensions

Approximate Dimensions in Inches (mm)

Group Metering Inline Current Transformer Cabinets

Height	Width	Depth
64.00 (1625.6)	26.50 (673.1)	15.00 (381.0)

#### Surge Metering

4



Surge suppression devices shown are factory mounted in Group Metering Enclosure.

#### Surge Metering

##### Product Description

Eaton’s multiple metering product family is proud to announce the availability of main surge devices. The new main surge is mounted between the main service module and the meter stacks and serves the purpose of providing surge protection for downstream multiple metering products. The main surge is compatible with all meter stacks currently manufactured (1MM, 3MM, 35MM and 37MM).

##### Features, Benefits and Functions

- Uses thermally protected metal oxide varistor (MOV) technology
- Compatible with 37MM enclosure accessories
- Protection status indicator lights EMI/RFI filtering and audible alarms
- Offers surge protection for all units fed from a main service module

##### Standards and Certifications

- UL 1449 3rd Edition recognized component



#### Contents

<i>Description</i>	<i>Page</i>
Systems for Residential and Commercial Applications . . . . .	<b>V1-T4-68</b>
Meter Packs . . . . .	<b>V1-T4-76</b>
Meter Packs—Tenant Circuit Breakers . . . . .	<b>V1-T4-88</b>
Main Service Modules . . . . .	<b>V1-T4-89</b>
Residential Meter Stacks . . . . .	<b>V1-T4-108</b>
Commercial Meter Stack Modules . . . . .	<b>V1-T4-123</b>
35MM, 37MM, 35SS and 37SS Tenant Main Circuit Breakers . . . . .	<b>V1-T4-130</b>
Phase Balanced Stack . . . . .	<b>V1-T4-132</b>
Group Metering Inline Current Transformer Cabinets . . . . .	<b>V1-T4-133</b>
Surge Metering . . . . .	<b>V1-T4-134</b>
Group Metering Accessories . . . . .	<b>V1-T4-135</b>

**Group Metering Accessories**



**Contents**

<b>Description</b>	<b>Page</b>
Systems for Residential and Commercial Applications . . . . .	<b>V1-T4-68</b>
Meter Packs . . . . .	<b>V1-T4-76</b>
Meter Packs—Tenant Circuit Breakers . . . . .	<b>V1-T4-88</b>
Main Service Modules . . . . .	<b>V1-T4-89</b>
Residential Meter Stacks . . . . .	<b>V1-T4-108</b>
Commercial Meter Stack Modules . . . . .	<b>V1-T4-123</b>
35MM, 37MM, 35SS and 37SS Tenant Main Circuit Breakers . . . . .	<b>V1-T4-130</b>
Phase Balanced Stack . . . . .	<b>V1-T4-132</b>
Group Metering Inline Current Transformer Cabinets . . . . .	<b>V1-T4-133</b>
Surge Metering . . . . .	<b>V1-T4-134</b>
Group Metering Accessories Product Selection . . . . .	<b>V1-T4-136</b>







**Group Metering Accessories**

These accessories are suited for the Group Metering product line. The products range from replacement parts, such as covers and sockets, to accessories that pair with the group metering lineup, such as elbows and spacers.

#### Product Selection

#### 1MP, 1MM and 3MM Residential Modular Metering Stacks

4

	Description	Application	Catalog Number
<b>Fifth Jaw Kit</b> 	Fifth jaw kit	Bolted onto neutral in the 3, 6 or 9 o'clock position. Typically used on network metering systems (three-phase in/single-phase out) or when specified by utility company.	<b>1MM5JK</b>
	Isolated fifth jaw kit	Connects to the neutral with an insulated wire.	<b>1MM5JKOP</b>
<b>Manual Bypass Kit</b> 	Manual bypass kit (ring style socket only)	For use with 125 A sockets only. (Not top socket.)	<b>1MMBPM125</b>
		For use with 200 A sockets only. (Not top socket.)	<b>1MMBPM200</b>
		This kit only to be used for top position of two- and three-high 125 A 1MM and 3MM stacks and of 2, 5 and six-position 125 A 1MP packs.	<b>1MMBPM125T</b>
		This kit only to be used for top position of 200 A two-position 1MP packs.	<b>1MMBPM200T</b>
<b>Horn Bypass Kit</b> 	Horn bypass	Used only on ringless cover stacks, kits can be installed on 125 A or 200 A sockets.  <b>Note:</b> For <b>1MP2122RRL</b> use:	<b>1MMBPH</b>  <b>WCG8HB</b> ①
	Meter bypass jumper	Installed on 125 A or 200 A sockets. Jumpers are plugged into jaws. Order Lexan® cover plate with bypass jumpers to prevent access to meter socket once energized. (Not UL listed.)	<b>1MMBPJ</b>
<b>Lexan Blank Cover</b> 	Lexan blank cover	Circular cover mounted on ring or ringless devices preventing access to meter socket while meter is not in place. Includes four plastic tabs that plug into each jaw.	<b>1MMPCP</b>
		Same as <b>1MMPCP</b> minus the tabs located in the back to plug into jaws. This device to be used while meter bypass jumpers are in place ( <b>1MMBPJ</b> ).	<b>1MMACP</b>
<b>Blank Meter Socket Cover</b> 	Blank meter socket cover	Used for 125 A stacks. Fits bottom socket only. Kit replaces existing meter cover preventing access to meter socket. Includes hasp for seal.	<b>1MMBC125B</b>
		Used on 200 A stacks. Fits bottom socket only. Kit replaces existing meter cover preventing access to meter socket. Includes hasp for seal.	<b>1MMBC200B</b>
<b>Wall Mounting Rail</b> 	Wall mounting rail	Rails are 4 feet (1.2m) in length. Bolted on wall for stacks, packs and mains to be hung.	<b>1MMWB</b>
<b>Bussed Spacer</b> 	Bussed spacer	Bussed spacer 1200 A 4-inch (101.6 mm). Required when stacks are mounted on right-hand side in EUSERC areas. (copper)	<b>3MMBSK</b> ②
		Bus duct riser/ meter center connection	Available in 400, 600, 800 A main fusible units only. Contact product line for details.

#### Notes

- ① WCG8HB only applies to meter packs built prior to 1998. Current meter packs use **1MMBPH**.
- ② Must be used when mounting MCB main next to an MTB main or another MCB main device.

**1MP, 1MM and 3MM Modular Residential Metering Stacks, continued**

	<b>Description</b>	<b>Application</b>	<b>Catalog Number</b>
<b>Indoor Corner Elbow</b> 	Indoor corner elbow (copper)	12-inch (304.8 mm) indoor corner elbow, 1200 A, three-phase, four-wire for use with 1MM and 3MM only. <b>Do not use with 35MM, 37MM, 35SS or 37SS stacks.</b> 12-inch corner elbow not EUSERC approved.	<b>3MMEB12</b>
	Indoor corner elbow (copper)	16-inch (406.4 mm) indoor corner elbow, 1200 A, three-phase, four-wire for use with 1MM, 3MM, 35MM, 37MM, 35SS and 37SS.	<b>3MMEB16</b>
	Barrier	Barrier for individual sockets	<b>1MMBK</b>
<b>Meter Jumper and Cover</b> 	Meter jumper and cover	Combination meter jumper and cover (200 A maximum). Used to jumper line and load jaws as well as cover meter socket preventing exposure to current carrying parts.	<b>1MMJCK</b>
	Lug block	125 A two-pole lug block assembly.	<b>BRSF125</b>
<b>Standard Sealing Ring</b> 	Sealing ring	Stainless steel screw type with brass screw	<b>1MMSR1</b>
		Standard (included with packs and stacks) ①	<b>1MMSR2</b>
		Stainless steel screw type with cast zinc screw	<b>1MMSR4</b>
		Aluminum screw type with locking provisions	<b>1MMSR5</b>
	Top endwall	125 A, NEMA 1 top end wall with knockouts for 1MM, 3MM meter stacks	<b>MM12N1WLK</b>
		200 A, NEMA 1 top end wall for 1MM, 3MM meter stacks	<b>MM20N1WLK</b>
<b>Barrel Lock Kit</b> 	Barrel lock kit	Needed when using barrel lock security, Main tenant feeders can exit bottom or back. Knockouts are available at all exit locations.	<b>3MMBLKIT</b>

**Note**

① Aluminum snap type.

#### Renewal Parts for Residential Modular Metering Stacks

##### 1MP, 1MM and 3MM Replacement Parts

	Description	Application	Catalog Number	
<b>Ringless Cover</b> 	Ringless cover (can install this to go from ring to ringless)	Installed on 125 A socket for ringless security	<b>1MMRC125</b>	
		Installed on 200 A socket for ringless security	<b>1MMRC200</b>	
		For use with top position of 125 A, two- and three-position, 1MM and 3MM stacks and two-, five- and six-position 1MP packs	<b>1MMRC125T</b>	
		Top-position two position IMP	<b>1MMRC200T</b>	
<b>Ring Cover</b> 	Ring cover	Installed on 125 A socket for ring security	<b>1MMCP1</b>	
		Installed on 200 A socket for ring security	<b>1MMCP2</b>	
		Top socket ring cover 125 A	<b>1MMCP1T</b>	
		Top socket ring cover 200 A	<b>1MMCP2T</b>	
<b>Tenant Breaker Cover</b> 	Tenant breaker hinged cover	125 A cover	<b>1MMBC1</b>	
		200 A cover	<b>1MMBC2</b>	
<b>Meter Socket</b> 	Meter socket ①	125 and 200 A	<b>1MMMS</b>	
		Busbar end cap	Flat—left side	<b>47-24139A</b>
			Bump—right side	<b>47-28172-2A</b>
		Main circuit breaker cover kit (black)		<b>49-7060</b>







#### Notes

① Meter Packs **1MP2122RRL** and **1MP2122RRLB** use different meter sockets.

See Renewal Parts listing RP.32A.01A.T.E for details.

See **RP00501001E** for a complete Renewal Parts listing.

Accessories for 35MM and 37MM Commercial Modular Metering Stacks

	Description	Application	Catalog Number
	Wall mounting rail	Rails are 4 feet (1.2m) in length. Bolted on wall for stacks, packs and mains to be hung.	1MMWB
	Indoor corner elbow (copper)	16-inch (406.4 mm) indoor corner elbow, 1200 A, three-phase, four-wire for use with 1MM, 3MM, 35MM, 37MM, 35SS and 37SS.	3MMEB16
<b>Handle Insulator</b>	Handle insulator	Each meter block includes a lever bypass. This kit includes the sleeve which slides onto the lever handle.	37MMHC
			
<b>Barrel Lock Bracket Kit</b>	Barrel lock bracket kit	Needed when using barrel lock security.	37MMBLK
			
<b>Totalizing Jumper Kit</b>	Totalizing jumper kit	Used if one socket is to meter two tenant feeds. When ordering jumper kit, should also order a plastic cover plate (1MMPCP + IMMJCK) preventing access to live parts on unused socket.	37MMTJK
			
<b>Type EHD and CV Breaker Retrofit Mounting Kit</b>	Type EHD and CV breaker retrofit mounting kit	Retrofit mounting hardware for installation of Type EHD and CV breakers in 35MM, 37SS, 37MM and 37SS meter stacks manufactured prior to February 2013. Order one kit per breaker.	37MMRCBK
			
<b>Type CV Breaker Mounting Kit</b>	Type CV breaker mounting kit	Replacement Type CV breaker mounting hardware kit. Used in 200 A 1MP/1MM/3MM modular metering stacks at 42, 65 and 100 kAIC.	1MMCBK
			
<b>Blank Cover Kit</b>	Blank cover kit	Kit replaces meter cover preventing access to socket.	37MMCK <sup>①</sup>
			37MMCKA <sup>②</sup>
<b>Three-Phase to Single-Phase Conversion Kit</b>	Barrier	Barrier for individual sockets	37MMBK
	Three-Phase to single-phase conversion kit	This kit will convert one three-phase meter socket (37MM devices) to a single-phase socket. Only needed if phasing A-C or C-B. If single-phase socket is to be phased A-B, kit is not required for field conversion. (Must use three-phase breaker.)	37MM1CK
	Bus duct riser/meter center connection	Available in 400, 600, 800 A Main fusible units and 400, 600, 800, 1000, 1200 main circuit breaker. Contact product line for details.	—
	Anti-inversion clip	This clip should be inserted into upper right hand jaw of a 320 A meter socket. The purpose is prevent a 200 A meter from being inserted into a 320 A meter socket.	37MMINVCLIP





Notes

- ① For all units made 10/2002 and earlier.
- ② For all units made after 11/2002.



#### Renewal Parts for Commercial Modular Metering Stacks

##### 35MM and 37MM Modular Metering Stacks

	Description	Application	Catalog Number
<b>35MM Replacement Meter Socket</b> 	35MM replacement meter socket	To replace meter socket with lever bypass and jaw release.	<b>MSLMSA1</b>
	37MM replacement meter socket	To replace meter socket with lever bypass and jaw release.	<b>MSLMSA2</b>
<b>37SS Replacement Meter Socket</b> 	35SS replacement meter socket	To replace meter socket with test bypass disconnect feature	<b>MSTMSA1</b>
	37SS replacement meter socket	To replace meter socket with test bypass disconnect feature	<b>MSTMSA2</b>
	Safety socket meter cover assembly	To replace ring type cover over the meter prior to 7/1/02.	<b>MSTMCVR1</b>
	Safety socket meter cover assembly	To replace ring type cover over the meter after 7/1/02	<b>MSTMCVR1E</b>
<b>Meter Cover Assembly</b> 	35MM and 37MM meter cover assembly	Prior to 12/1/02	<b>37MMSK</b>
		After 12/1/02	<b>37MMSK1</b>
	Meter cover assembly with NJ latch	To replace ringless cover over the meter. Includes New Jersey latch requirement.	<b>37MMSKNJ</b>
<b>Tenant Breaker Hinged Cover</b> 	Tenant breaker hinged cover	To replace cover over tenant breakers.	<b>1MMBC2</b>
	Busbar end cap	Flat—left side	<b>47-24139A</b>
		Bump—right side	<b>47-28172-2A</b>
	Main circuit breaker cover/CIT (black)		<b>49-7060</b>

**Note**

See **RP.32A.01.T.E** for a complete Renewal Parts listing.

1MPLK3



**Main Lug Selection—Field-Installed Lugs for 400 or 600 A Main Bus**  
(For use with Meter Packs only)

**Line Lug and Wire Sizes**  
**Order Separately and Field Install**

**Line Lug Kit Catalog Number**  
**Order Three Kits**  
**(For Two Lines and Neutral)**

(1) #6–600 kcmil or (2) 2/0–250 kcmil	<b>1MPLK1</b>
(2) 250–500 kcmil	<b>1MPLK3</b>
(3) #4–300 kcmil	<b>1MPLK4</b> ①
(1) 750 kcmil	<b>1MPLK2</b> ②
Crimp lug landing pad 250–750 kcmil	<b>1MPSC1</b> ①

**Field Installable Lug Kits for 1MM and 3MM Tenant Main Circuit Breakers**  
(For use with Residential Meter Stacks to account for bigger wire sizes)

BR40LUG



Description	Catalog Number
4/0 Lug adapter—accommodates 3/0–4/0	<b>BR40LUG</b>

BR40NEU



4/0 Neutral bar adapter—accommodates #1–4/0	<b>BR40NEU</b>
---	----------------

Up-sized ground bar kit	<b>1MMGBK</b>
Two-pole 300 kcmil with terminal shield	<b>2TA225CVK</b>
Three-pole 300 kcmil with terminal shield	<b>3TA225CVK</b>
Replacement mounting hardware kit for 200 A 1MP, 1MM and 3MM units	<b>1MMCBK</b>

**Wire Sizes—Neutral and Ground Lugs**

Description	Wire Size, Al/Cu	Catalog Number
Neutral—125 A meter pack	#6–2/0	—
Neutral—200 A meter pack	#1/0–300 kcmil	—
Equipment ground bar—125 A meter pack	#14–#2	—
Equipment ground bar—200 A meter pack	#14–2/0	—
Optional ground bar	#6–2/0	<b>1MMGBK</b>

**BR40LUG Compatibility Chart**

Type	60 A	70 A	80 A	90 A	100 A	110 A	125 A
BR	—	—	—	—	—	<b>BR2110</b>	<b>BR2125</b>
BRH	—	—	—	—	—	<b>BRH2110</b>	<b>BRH2125</b>
BRHX	—	—	—	—	—	<b>BRHX2110</b>	<b>BRHX2125</b>
BRHH	—	—	—	—	—	<b>BRHH2110</b>	<b>BRHH2125</b>
BRX	<b>BRX260</b>	<b>BRX270</b>	<b>BRX280</b>	<b>BRX290</b>	<b>BRX2100</b>	<b>BRX2110</b>	<b>BRX2125</b>

**Other Notes for Lug Kits**

**Notes:** The lug adapter kit can be used in 1MM and 3MM 3- through 6-socket 125 A modular metering stacks. Only intended for use in bottom- and rear-feed applications. Four adapters can be used per meter stack.

**Notes**

① This kit comes with three pads for two lines and neutral. Each pad will accept one or two crimp lugs. Cannot be used on **1MP2122R**, **RL**, **RC** and **RLB** EUSERC underground termination.

② This lug is not UL listed.

Each stack includes a neutral and ground bar. If an extra ground bar is needed, order **1MMGBK**.

Power Pedestals



Construction Site and RV Parks



Marina Power and Lighting



Mobile Home Panels

<b>5.1 Introduction</b>	
Product Description	V1-T5-2
Application Description	V1-T5-2
Optional Features	V1-T5-2
<b>5.2 Temporary Power/RV Park</b>	
Product Overview	V1-T5-3
Product Description	V1-T5-3
Application Description	V1-T5-4
Features and Benefits	V1-T5-4
Standards and Certifications	V1-T5-5
Catalog Number Selection	V1-T5-6
Product Selection	V1-T5-7
Accessories	V1-T5-7
Renewal Parts	V1-T5-8
Surface Units	V1-T5-10
Product Overview	V1-T5-10
Product Selection	V1-T5-10
Dimensions	V1-T5-13
Pedestal Units	V1-T5-16
Product Overview	V1-T5-16
Product Selection	V1-T5-16
Dimensions	V1-T5-18
<b>5.3 Mobile Home Panels</b>	
Product Overview	V1-T5-21
Features	V1-T5-21
Catalog Number Selection	V1-T5-22
Product Selection	V1-T5-22
Accessories	V1-T5-23
Dimensions	V1-T5-24
<b>5.4 RV Park Hook-Ups</b>	
Power Pedestals	V1-T5-28
Powerhouse Power Pedestal	V1-T5-30
Powerhouse—Stainless Steel (SS) Power Pedestal	V1-T5-33
Newport Camp Mate Power Pedestal	V1-T5-36
Park Light Power Pedestal	V1-T5-39
Firehouse	V1-T5-42
Digital Electronic Kilowatthour Meters	V1-T5-44
Distribution Equipment—Ground Fault Monitor	V1-T5-45
Distribution Equipment—Substations	V1-T5-46
Distribution Equipment—Panels	V1-T5-49
Distribution Equipment—Transformers	V1-T5-50
<b>5.5 Marina Power and Lighting Equipment</b>	
Power Pedestals	V1-T5-51
Lighthouse	V1-T5-54
Lighthouse—SS	V1-T5-58
Admiral—SS	V1-T5-62
Newport Harbor Mate	V1-T5-65
Hatteras Light	V1-T5-69
Firehouse	V1-T5-73
Smart Start	V1-T5-79
Mariner	V1-T5-80
Digital Electronic Kilowatthour Meters	V1-T5-81
Distribution Equipment—Ground Fault Monitor	V1-T5-82
Distribution Equipment—Mega Yacht Powerpoint	V1-T5-83
Distribution Equipment—Substations	V1-T5-86
Distribution Equipment—Panels	V1-T5-89
Distribution Equipment—Transformers	V1-T5-90

**Don't Give Up!**

If you don't find the product you want in this catalog, try the Flex Center at **1-800-330-6479**.

### Power Pedestals



5

### Contents

#### Description

Introduction

### Product Description

A power pedestal is a device designed for outdoor service to meet temporary power requirements at construction sites, marinas, recreational vehicle (RV parks, marinas and mobile home parks). Power pedestals provide a safe and reliable means for users to access electricity at such locations.

### Application Description

#### Construction Site and RV Parks

Power outlet panels on construction sites and in RV parks provide a safe and reliable means for users to access electricity. A wide range of products are available with multiple features and enclosure material options.



**Construction Site and RV Parks**

#### Mobile Home Panels

Eaton's versatile mobile home panels have a user-friendly design that allows for a faster, cleaner installation. Mobile home panels are designed for service entrance distribution, and include a meter and distribution section with breaker and receptacle configuration options.



**Mobile Home Panels**

#### Marina Power and Lighting

Park lighting and marina pedestals offer robust enclosure options with premium features to enhance user convenience at marinas and campgrounds.



**Marina Power and Lighting**

### Optional Features

- Product can ship from the factory completely assembled and prewired
- External light
- TV and telephone jacks
- Ground fault monitors
- Digital electronic kilowatt-hour meters
- Water faucet
- Available GFI (ground fault interrupter) protection
- Weatherproof engineered resin enclosure (will never rust or deteriorate)
- Stainless steel to meet and exceed all applicable codes, and withstand harsh inland and coastal environments

## Power Outlet Panels



## Product Overview

A power outlet panel (or POP) is a device designed for outdoor service to meet temporary power requirements at construction sites and RV parks. POPs provide a safe and reliable means for users to access electricity at such locations.

## Product Description

Power outlet panels shall be designed for outdoor service to meet temporary power outlet requirements at construction sites and provide high quality, economical power to individual sites at RV parks. POPs shall be provided with means to bond the neutral for temporary service entrance applications. RV panels shall have a factory-installed insulated neutral bar.

## Receptacles and Circuit Protection

Circuit protection shall be Eaton's UL listed full-size Type BR or half-size Type BD circuit breakers. The receptacles shall be NEMA commercial/industrial grade devices. Ground fault protection (GFCB) shall be provided at the 20 A duplex NEMA 5-20R receptacle or 20 A single-pole circuit breaker per UL standards. Ground fault protection shall be provided at the circuit breaker for receptacles above 20 A per UL standards.

## Contents

### Description

Product Overview . . . . .	V1-T5-3
Application Description . . . . .	V1-T5-4
Features and Benefits . . . . .	V1-T5-4
Standards and Certifications . . . . .	V1-T5-5
Catalog Number Selection . . . . .	V1-T5-6
Product Selection . . . . .	V1-T5-7
Accessories . . . . .	V1-T5-7
Renewal Parts . . . . .	V1-T5-8
Surface Units . . . . .	V1-T5-10
Pedestal Units . . . . .	V1-T5-16

### Construction

The power outlet panel pedestal shall be of deadfront design and constructed of heavy gauge, 100 percent galvanized steel. Baked-on polyester powder coating shall be used for excellent mechanical strength, plus resistance to chalking caused by the sun's ultraviolet rays. The power outlet panel surface and pedestal units shall have NEMA Type 3R rainproof enclosures.

### Ease of Installation

Panels shall ship from the factory completely assembled, prewired with aluminum wire, and tested in accordance with UL Standard 231. The door shall swing up and open for user convenience and ease of access to breakers and receptacles. When required, a means for securing the door in the open position shall be provided. Panels shall be bottom fed through knockouts in endwall or top fed using a bolt-on raintight hub. Knockouts shall range from 1/2-inch (12.7 mm) to 1-1/2 inches (38.1 mm). Grounding provisions (#4–14 Cu/Al) shall be provided on all panels.

**Application Description**

POPs are also sometimes called temporary power panels, temporary site service equipment or RV panels.

**Construction Site Application**

When POPs are used at a construction site, they are installed on a temporary basis until permanent electrical power is available at the building. The most common reason for needing a POP at a construction site is to provide a power source for the contractor's tools.



*Construction Site Application*

**RV Park Applications**

When POPs are used at an RV park, they are installed for more permanent use and serve the purpose of providing power to the recreational vehicles. Many RV parks now supply customers with amenities such as lighted POPs with TV and telephone jacks.



*RV Park Application*

**Service Applications**

Suitable for use as temporary Service Entrance Equipment, temporary power service equipment and recreational vehicle site supply.

**Features and Benefits**

- Designed for outdoor service to meet power outlet requirements
- Receptacles conform to NEMA and/or ANSI configurations as specified by the National Electrical Code® (NEC)
- Includes a factory-installed insulated neutral bar with provisions for bonding when used for temporary service entrance applications
- 125 A rated meter socket
- Temporary power and RV park POPs are CSA listed. Compact POP and single receptacle devices are not CSA listed

**Designed for Easy Installation and Protection**

- Panels come from the factory completely assembled, prewired with aluminum wire and tested... ready for easy installation
- Door swings up and open for user convenience and ease of access to breakers and receptacles
- Panels can be bottom fed through knockouts in the endwall or top fed using a bolt-on raintight hub
- Two-piece deadfront cover allows field wiring without interfering with factory wiring
- Lower deadfront cover permits easy field wiring to circuit protective devices
- Available GFI (ground fault interrupter) single- and two-pole protection through 50 A

**Two Styles to Meet Your Power Outlet Needs**

- **Surface mount:** User mounts unit to a post
- **Pedestal mount:** User mounts with an underground pedestal extension or pad-mounting bracket. (Underground pedestal extension and pad-mounting bracket are sold separately. See accessories **Page V1-T5-7** for part numbers and options)



*Compact Design Available in Certain Configurations for Added Convenience*

**Surface Units**



- 100 percent galvanized steel with baked-on polyester powder coating
- Three-point mounting
- One-piece case back for metered and unmetered panels
- Lighted option for site location and nighttime panel operations
- GFI circuit breakers available through 50 A
- Unique steel barrier prevents unauthorized operation of breakers when door is closed and padlocked

- NEMA 3R construction for rainproof installation
- Utility grade metering available for construction site or RV park applications
- Door swings up when opening and allows cords to remain connected when closed.
- Removable upper deadfront cover for easy incoming wire connections to breaker terminals
- Lower deadfront cover can be removed for easy routing of incoming wires or receptacle changeouts
- Padlock provisions to prevent unauthorized entry

- Metered units available with meter on top or on bottom
- Units are factory wired and assembled

**Pedestal Units**

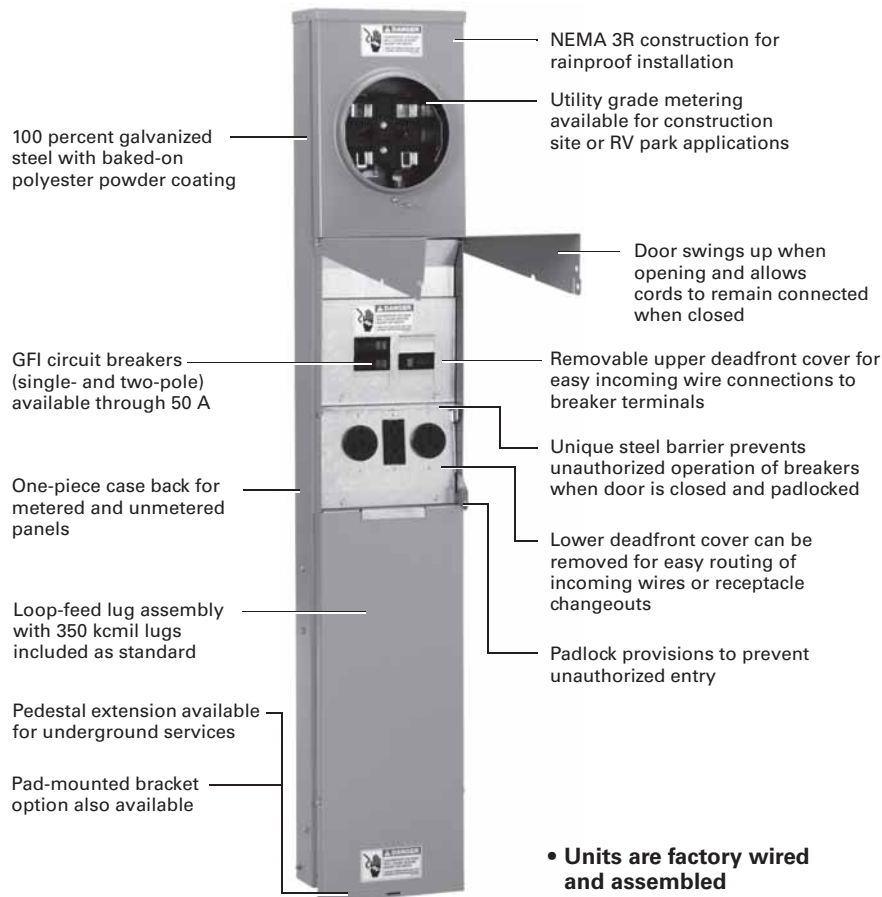

- 100 percent galvanized steel with baked-on polyester powder coating
- GFI circuit breakers (single- and two-pole) available through 50 A
- One-piece case back for metered and unmetered panels
- Loop-feed lug assembly with 350 kcmil lugs included as standard
- Pedestal extension available for underground services
- Pad-mounted bracket option also available

- NEMA 3R construction for rainproof installation
- Utility grade metering available for construction site or RV park applications
- Door swings up when opening and allows cords to remain connected when closed
- Removable upper deadfront cover for easy incoming wire connections to breaker terminals
- Unique steel barrier prevents unauthorized operation of breakers when door is closed and padlocked
- Lower deadfront cover can be removed for easy routing of incoming wires or receptacle changeouts
- Padlock provisions to prevent unauthorized entry

- Units are factory wired and assembled

**Standards and Certifications**

- UL Standard 231
  - UL File Number E163588
- Receptacles conform to NEMA and/or ANSI configurations as specified by the NEC.

**Standard Compliance**

All power outlet panels for temporary construction site power and RV (recreational vehicle) application shall be UL listed for the U.S. per UL Standard 231, File E163588. Receptacles shall conform to NEMA and/or ANSI configurations as specified by the National Electrical Code (NEC).



#### Catalog Number Selection



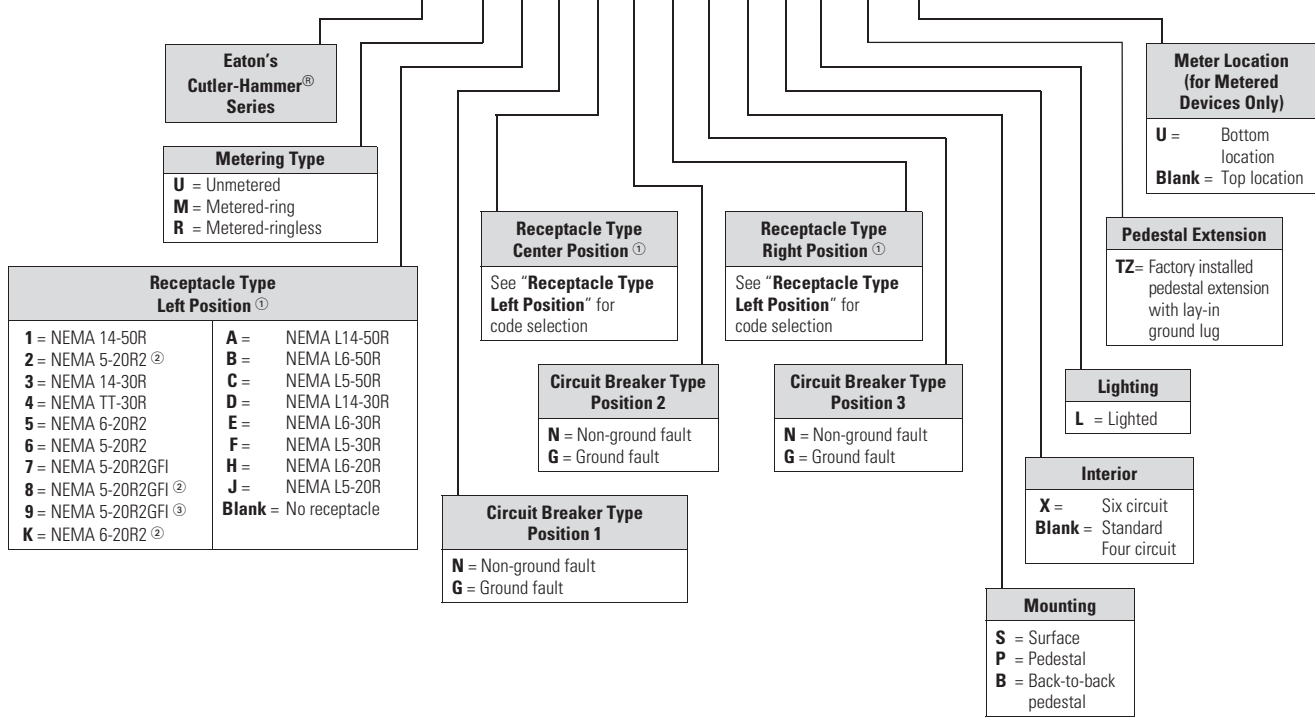







**C H M 1 N 7 N 4 N P X L T Z U**











#### Notes

- ① For receptacle configurations, see **table below**.
- ② Weather-resistant.
- ③ Weather-resistant/tamper resistant.

#### Receptacle Configuration

<b>1</b>	 50 A, 125/250 V, three-pole, four-wire, <b>NEMA 14-50R</b> Two-pole, 50 A breaker	<b>4</b>	 30 A, 125 V, two-pole, three-wire, <b>NEMA TT-30R</b> Single-pole, 30 A breaker	<b>7</b>	 20 A, 125 V, two-pole, three-wire, <b>NEMA 5-20R2GFI</b> Single-pole, 20 A breaker
<b>2</b>	 20 A, 125 V, two-pole, three-wire, weather-resistant (WR), <b>NEMA 5-20R2</b> Single-pole, 20 A breaker	<b>5</b>	 20 A, 250 V, two-pole, three-wire, <b>NEMA 6-20R2</b> Two-pole, 20 A breaker	<b>8</b>	 20 A, 125 V, two-pole, three-wire, weather-resistant (WR), <b>NEMA 5-20R2GFI</b>
<b>3</b>	 30 A, 125/250 V, three-pole, four-wire, <b>NEMA 14-30R</b> Two-pole, 30 A breaker	<b>6</b>	 20 A, 125 V, two-pole, three-wire, <b>NEMA 5-20R2</b> Single-pole, 20 A breaker	<b>9</b>	 20 A, 125 V, two-pole, three-wire, weather-resistant/tamper-resistant (WR TR), <b>NEMA 5-20R2GFI</b>
				<b>K</b>	 20 A, 250 V, two-pole, three-wire, weather-resistant (WR), <b>NEMA 6-20R2</b> Two-pole, 20 A breaker

#### Twist-Lock and Custom Receptacle/Breaker Combinations

<b>A</b>	 50 A, 125/250 V, three-pole, three-wire, <b>NEMA L14-50R</b> Two-pole, 50 A breaker	<b>D</b>	 30 A, 125/250 V, three-pole, four-wire, <b>NEMA L14-30R</b> Two-pole, 30 A breaker	<b>H</b>	 20 A, 250 V, two-pole, three-wire, <b>NEMA L6-20R</b> Two-pole, 20 A breaker
<b>B</b>	 50 A, 250 V, two-pole, three-wire, <b>NEMA L6-50R</b> Two-pole, 50 A breaker	<b>E</b>	 30 A, 250 V, two-pole, three-wire, <b>NEMA L6-30R</b> Two-pole, 30 A breaker	<b>J</b>	 20 A, 125 V, two-pole, three-wire, <b>NEMA L5-20R</b> Single-pole, 20 A breaker
<b>C</b>	 50 A, 125 V, two-pole, three-wire, <b>NEMA L5-50R</b> Single-pole, 50 A breaker	<b>F</b>	 30 A, 125 V, two-pole, three-wire, <b>NEMA L5-30R</b> Single-pole, 30 A breaker		



**Product Selection**

When quoting or selecting a power outlet panel, the following questions should be answered:

- Unmetered, ring or ringless style
- Number and types of receptacles (seven standard and eight twist-lock options)
- Standard or ground fault breakers
- Surface, pedestal or back-to-back mounting
- Are any factory or field options required?

**Power Outlet Panel Receptacle Configuration Rules**

**Note:** All Power Outlet Panel Configurations using **NEMA 5-20R2** receptacles, including 2 and 6, must be paired with a ground fault breaker.

**Four Receptacles/Unit**

All receptacles must be NEMA 5-20R2 or NEMA 5-20R2GFI, surface mount only.

**Three Receptacles/Unit**

- One or more of the receptacles must be NEMA 6-20R2, NEMA 5-20R2 or NEMA 5-20R2GFI

- NEMA 6-20R2, NEMA 5-20R2, or NEMA 5-20R2GFI must go in the second position
- If two receptacles consist of types NEMA 14-50R, NEMA 10-50R, NEMA 14-30R or NEMA 6-20R2 a six-circuit interior must be added
  - Example:  
**CHUIN5N2NSX**





**Note:** Configuration 1 and 2 were chosen so a six-circuit interior needs to be added (suffix X) to the end of the catalog number. Also, configuration 5 is in the second position.

**Two, One and Zero Receptacles/Unit**

Any configuration.

**Accessories**

**Accessories**







	Description	Catalog Number
<b>Underground Pedestal Extension</b> 	Underground pedestal extension	CHPEEXT
	Stainless steel underground pedestal extension	CHPEEXTSS
<b>Pad-Mount Bracket</b> 	Pad-mount bracket	CHPADEXT
<b>Cable TV/Telephone Bracket</b> 	Cable TV and telephone bracket	CHTELTV
<b>DS Hub</b> 	Rainproof conduit hub 0.75 inch (19.1 mm)	DS075H1
	Rainproof conduit hub 1.00 inch (25.4 mm)	DS100H1
	Rainproof conduit hub 1.25 inch (31.8 mm)	DS125H1
	Rainproof conduit hub 1.50 inch (38.1 mm)	DS150H1

**Fluorescent Light Kit**





	Description	Catalog Number
	Converts power outlet panel to lighted unit, <b>must also order CHOUTCVRL</b>	CHFLGKIT

#### Renewal Parts

#### Renewal Parts

	Description	Catalog Number
<b>Circuit Breaker (BR/GFTCB)</b> 	See this volume, Tab 1, section 1.2	—
<b>Meter Socket</b> 	Ring style replacement meter socket	<b>CHPOPMSRING</b>
	Ringless style replacement meter socket	<b>CHPOPMSRL</b>
	5th jaw kit	<b>ARP00035CHJ</b>
	Horn bypass (one lug cap per kit; four kits required per device)	<b>ARP00777CH</b>
<b>Bonding Strap and Mounting Hardware</b> 	Bonding strap and mounting hardware	<b>CHBONDST</b>
<b>Inner Lens</b> 	Inner lens for lighted power outlet panels	<b>CHINLENS</b>
<b>Loop Feed Lug Assembly</b> 	Loop feed lug assembly for single pedestal	<b>CHLOOPFDP</b>
	Loop feed lug assembly for back-to-back pedestal	<b>CHLOOPFDB</b>
<b>Lower Deadfront Cover</b> 	Blank lower deadfront cover	<b>CHLDFCVR</b>
	Lower deadfront cover with duplex receptacle opening	<b>CHLDFCVR1</b>
	Lower deadfront cover with duplex, duplex receptacle opening	<b>CHLDFCVR2</b>
	Lower deadfront cover with duplex, duplex, duplex receptacle opening	<b>CHLDFCVR3</b>
	Lower deadfront cover with rectangle receptacle opening	<b>CHLDFCVR4</b>
	Lower deadfront cover with rectangle, rectangle receptacle opening	<b>CHLDFCVR5</b>
	Lower deadfront cover with rectangle, rectangle, rectangle receptacle opening	<b>CHLDFCVR6</b>
	Lower deadfront cover with duplex, rectangle receptacle opening	<b>CHLDFCVR7</b>
	Lower deadfront cover with duplex, rectangle, duplex receptacle opening	<b>CHLDFCVR8</b>
	Lower deadfront cover with rectangle, rectangle, duplex receptacle opening	<b>CHLDFCVR9</b>
	Lower deadfront cover with round receptacle opening	<b>CHLDFCVR10</b>
	Lower deadfront cover with round, round receptacle opening	<b>CHLDFCVR11</b>
	Lower deadfront cover with round, duplex receptacle opening	<b>CHLDFCVR12</b>

## Renewal Parts, continued

	Description	Catalog Number
	Lower deadfront cover with round, duplex, duplex receptacle opening	CHLDFCVR13
	Lower deadfront cover with round, duplex, round receptacle opening	CHLDFCVR14
	Lower deadfront cover with round, rectangle receptacle opening	CHLDFCVR15
	Lower deadfront cover with round, rectangle, rectangle receptacle opening	CHLDFCVR16
	Lower deadfront cover with round, rectangle, round receptacle opening	CHLDFCVR17
	Lower deadfront cover with round, rectangle, duplex receptacle opening	CHLDFCVR18
<b>Upper Deadfront Cover</b>	Upper deadfront cover with six breaker twistouts	CHUDFCVR
	Upper deadfront cover with provisions for lighted option	CHUDFCVRL
		
<b>Outer Door</b>	Outer door	CHOUTCVR
		
<b>Outer Door with Lens</b>	Outer door with lens	CHOUTCVRL
		
<b>Neutral Assemblies</b>	Six-hole neutral assembly with 2/0 lug	CHNEUT
	Seven-hole neutral assembly with 2/0 lug	CHNEUT1
	Five-hole ground bar kit	GBK5
	10-hole ground bar kit	GBK10
		
	<b>Replacement Meter Cover</b>	
	Replacement meter cover—ring type	CHPOPRMC
	Replacement meter cover—ringless	CHPOPRLMC
	Replacement meter cover—ringless	CHPOPRLMCN
	Replacement meter cover—ringless	CHPOPRLMCN2

#### Power Outlet Panels



5

### Surface Units

#### Product Overview

A power outlet panel (or POP) is a device designed for outdoor service to meet temporary power requirements at construction sites and recreation vehicle (RV) parks. POPs provide a safe and reliable means for users to access electricity at such locations.

#### Product Selection

##### Power Outlet Panel Receptacle Configuration Rules

**Note:** All Power Outlet Panel Configurations using **NEMA 5-20R2** receptacles, including 2 and 6, must be paired with a ground fault breaker.

See **Page V1-T5-7** for complete list.

##### Four Receptacles/Unit

All receptacles must be NEMA 5-20R2 and/or NEMA 5-20R2GFI, surface mount only.

### Contents

#### Description

	<i>Page</i>
Product Overview .....	<b>V1-T5-3</b>
Surface Units	
Dimensions .....	<b>V1-T5-13</b>
Pedestal Units .....	<b>V1-T5-16</b>

##### Three Receptacles/Unit

- One or more of the receptacles must be NEMA 6-20R2, NEMA 5-20R2 or NEMA 5-20R2GFI
- NEMA 6-20R2, NEMA 5-20R2, or NEMA 5-20R2GFI must go in the second position
- If two receptacles consist of types NEMA 14-50R, NEMA 10-50R, NEMA 14-30R or NEMA 6-20R2 a six-circuit interior must be added
  - Example:  
**CHUI5N2NSX**

##### Two, One and Zero Receptacles/Unit

Any configuration.

##### Options

- Six-circuit interior
- Factory-mounted pedestal extension
- Lighted
- Bottom fed

**Note:** Configuration 1 and 2 were chosen so a six-circuit interior needs to be added (suffix X) to the end of the catalog number. Also, configuration 5 is in the second position.

## Surface Type

Ampere Series	Receptacle Description			Breaker Description			Catalog Number	
	Position	Left	Center	Right	1st	2nd		3rd
<b>Single Receptacle CHU4S</b>								
<b>Unmetered Single Receptacle</b>								
50	—	14-50R	—	—	No breaker	No breaker	No breaker	<b>CHU1S</b>
30	—	14-30 R	—	—	No breaker	No breaker	No breaker	<b>CHU3S</b>
30	—	TT-30R	—	—	No breaker	No breaker	No breaker	<b>CHU4S</b>
20	—	6-20R2	—	—	No breaker	No breaker	No breaker	<b>CHU5S</b>
20	—	5-20R2	—	—	No breaker	No breaker	No breaker	<b>CHU6S</b>
20	—	5-20R2GFI	—	—	No breaker	No breaker	No breaker	<b>CHU7S</b>
<b>Unmetered Type CHU1N7N4NS</b>								
<b>Unmetered</b>								
20/20/20	5-20R2	5-20R2	6-20R2	GFI	GFI	GFI		<b>CHU6G6G5GS</b>
20/20/20	5-20R2WR	5-20R2WR	6-20R2WR	GFI	GFI	GFI		<b>CHU2G2GKGS</b>
20/20/20	5-20R2GFI	5-20R2GFI	6-20R2	Non-GFI	Non-GFI	Non-GFI		<b>CHU7N7N5NS</b>
20/20/20	5-20R2GFIWR	5-20R2GFIWR	6-20R2WR	Non-GFI	Non-GFI	Non-GFI		<b>CHU8N8NKNS</b>
20/20/20	5-20R2GFI	5-20R2GFI	6-20R2	Non-GFI	Non-GFI	GFI		<b>CHU7N7N5GS</b>
20/20/20	5-20R2GFIWR	5-20R2GFIWR	6-20R2WR	Non-GFI	Non-GFI	GFI		<b>CHU8N8NKGS</b>
50/20/30	14-50R	5-20R2GFI	TT-30R	Non-GFI	Non-GFI	Non-GFI		<b>CHU1N7N4NS</b>
50/20/30	14-50R	5-20R2GFI	6-20R	GFI	Non-GFI	Non-GFI		<b>CHU1G7N7NS</b>
50/20	14-50R	5-20R2GFI	—	GFI	Non-GFI	—		<b>CHU1G7NS</b>
50/20	14-50R	5-20R2GFI	—	Non-GFI	Non-GFI	—		<b>CHU1N7NS</b>
50/20/50	14-50R	5-20R2GFI	14-50R	Non-GFI	Non-GFI	Non-GFI		<b>CHU1N7N1NSX</b> <sup>①</sup>
30/30/20	TT-30R	5-20R2GFI	TT-30R	Non-GFI	Non-GFI	Non-GFI		<b>CHU4N7N4NS</b>
20/20/20	5-20R2	5-20R2	6-20R2	GFI	GFI	GFI		<b>CHU6G6G5GS60M</b> <sup>②</sup>
<b>Unmetered (Compact Version)</b>								
50	14-50R	—	—	—	Non-GFI	—	—	<b>CHU1NS</b>
20	5-20R2	—	—	—	Non-GFI	—	—	<b>CHU2NS</b>
30	TT-30R	—	—	—	GFI	—	—	<b>CHU4GS</b>
30/30	TT-30R	TT-30R	—	—	Non-GFI	Non-GFI	—	<b>CHU4N4NS</b>
30/20	TT-30R	5-20R2GFI	—	—	Non-GFI	Non-GFI	—	<b>CHU4N7NS</b>
30	TT-30R	—	—	—	Non-GFI	—	—	<b>CHU4NS</b>
20	6-20R2	—	—	—	GFI	—	—	<b>CHU5GS</b>
20/20	5-20R2	5-20R2	—	—	GFI	GFI	—	<b>CHU6G6GS</b>
20	5-20R2	—	—	—	GFI	—	—	<b>CHU6GS</b>
20/20	5-20R2GFI	5-20R2GFI	—	—	Non-GFI	Non-GFI	—	<b>CHU7N7NS</b>
20	5-20R2GFI	—	—	—	Non-GFI	—	—	<b>CHU7NS</b>

**Notes**

① The "X" suffix indicates that a six circuit interior is provided, instead of the standard four circuit interior.

② Includes 60 A two-pole main breaker for service disconnect ratings.

Contact your local Eaton sales office for configurations not listed.

#### Surface Type, continued

**Metered Ring  
CHM1G7NS**



Ampere Series	Receptacle Description			Breaker Description			Catalog Number
	Position Left	Center	Right	1st	2nd	3rd	
<b>Metered – Ring</b>							
50/20/20	14-50R	5-20R2GFI	5-20R2GFI	GFI	Non-GFI	Non-GFI	<b>CHM1G7N7NS</b>
20/20	5-20R2GFI	5-20R2GFI	—	Non-GFI	Non-GFI	—	<b>CHM7N7NS</b>
20/20/20	5-20R2GFI	5-20R2GFI	6-20R2	Non-GFI	Non-GFI	GFI	<b>CHM7N7N5GS</b>
20/20/20	5-20R2GFI	5-20R2GFI	6-20R2	Non-GFI	Non-GFI	Non-GFI	<b>CHM7N7N5NS</b>
50/30/20	14-50R	5-20R2GFI	TT-30R	Non-GFI	Non-GFI	Non-GFI	<b>CHM1N7N4NS</b>
50/20	14-50R	5-20R2GFI	—	Non-GFI	Non-GFI	—	<b>CHM1N7NS</b>
20/20	6-20R2	5-20R2GFI	—	Non-GFI	Non-GFI	Non-GFI	<b>CHM5N7NS</b>

**Metered Ringless Type  
CHR4N7NS**



<b>Metered – Ringless</b>							
50/20	14-50R	5-20R2GFI	—	GFI	Non-GFI	—	<b>CHR1G7NS</b>
20/20	5-20R2GFI	5-20R2GFI	—	Non-GFI	Non-GFI	—	<b>CHR7N7NS</b>
50/20/20	14-50R	5-20R2GFI	5-20R2GFI	GFI	Non-GFI	Non-GFI	<b>CHR1G7N7NS</b>
50/20	14-50R	5-20R2GFI	—	Non-GFI	Non-GFI	—	<b>CHR1N7NS</b>
20/20/20	5-20R2GFI	5-20R2GFI	5-20R2GFI	Non-GFI	Non-GFI	Non-GFI	<b>CHR7N7N7NS</b>
20/20/20	5-20R2WR	5-20R2WR	6-20R2WR	GFI	GFI	GFI	<b>CHR2G2GKGS</b>
30/20/20	14-30R	5-20R2GFI	5-20R2GFI	Non-GFI	Non-GFI	Non-GFI	<b>CHR3N7N7NS</b>
50/30/20	14-50R	5-20R2GFI	TT-30R	Non-GFI	Non-GFI	Non-GFI	<b>CHR1N7N4NS</b>

**Metered Ring or  
Ringless Type  
Bottom Fed**



<b>Metered – Ring – Bottom Fed</b>							
20/20	5-20R2GFI	5-20R2GFI	—	Non-GFI	Non-GFI	—	<b>CHM7N7NSU</b>
20/20/20	5-20R2GFI	5-20R2GFI	6-20R2	Non-GFI	Non-GFI	GFI	<b>CHM7N7N5GSU</b>
50/20/20	14-50R	5-20R2GFI	5-20R2GFI	GFI	Non-GFI	Non-GFI	<b>CHM1G7N7NSU</b>
<b>Metered – Ringless – Bottom Fed</b>							
20/20	5-20R2GFI	5-20R2GFI	—	Non-GFI	Non-GFI	—	<b>CHR7N7NSU</b>
50/20	14-50R	5-20R2GFI	—	GFI	Non-GFI	—	<b>CHR1G7NSU</b>
50/20	10-50R	5-20R2GFI	—	GFI	Non-GFI	—	<b>CHR2G7NSU</b>
20/20/20	5-20R2WR	5-20R2WR	6-20R2WR	GFI	GFI	GFI	<b>CHR2G2GKGSU</b>
20/20/20	5-20R2GFI	5-20R2GFI	6-20R2	Non-GFI	Non-GFI	GFI	<b>CHR7N7N5GSU</b>
20/20/20	5-20R2GFI	5-20R2GFI	6-20R2	Non-GFI	Non-GFI	Non-GFI	<b>CHR7N7N5NSU</b>
20/20/20	5-20R2GFI	5-20R2GFI	5-20R2GFI	Non-GFI	Non-GFI	Non-GFI	<b>CHR7N7N7NSU</b>
30/20/20	14-30R	5-20R2GFI	5-20R2GFI	Non-GFI	Non-GFI	Non-GFI	<b>CHR3N7N7NSU</b>
30/20/20	14-30R	5-20R2GFI	5-20R2GFI	GFI	Non-GFI	Non-GFI	<b>CHR3G7N7NSU</b>
50/20/20	14-50R	5-20R2GFI	5-20R2GFI	GFI	Non-GFI	Non-GFI	<b>CHR1G7N7NSU</b>
50/20/30	14-50R	5-20R2GFI	TT-30R	Non-GFI	Non-GFI	Non-GFI	<b>CHR1N7N4NSU</b>

#### Accessories

See **Page V1-T5-7**.

**Dimensions**

Approximate Dimensions in Inches (mm)

**Single Receptacle**

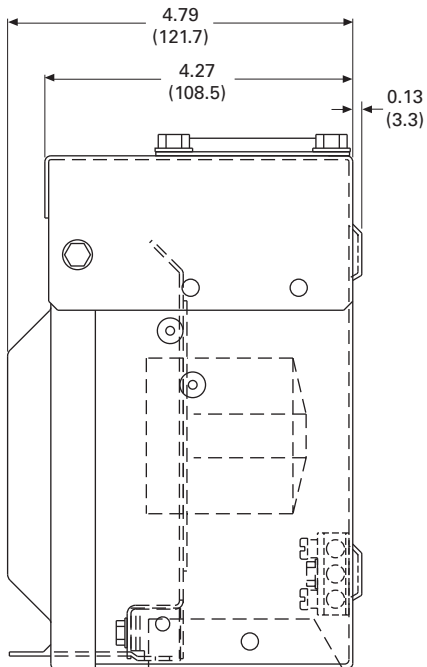
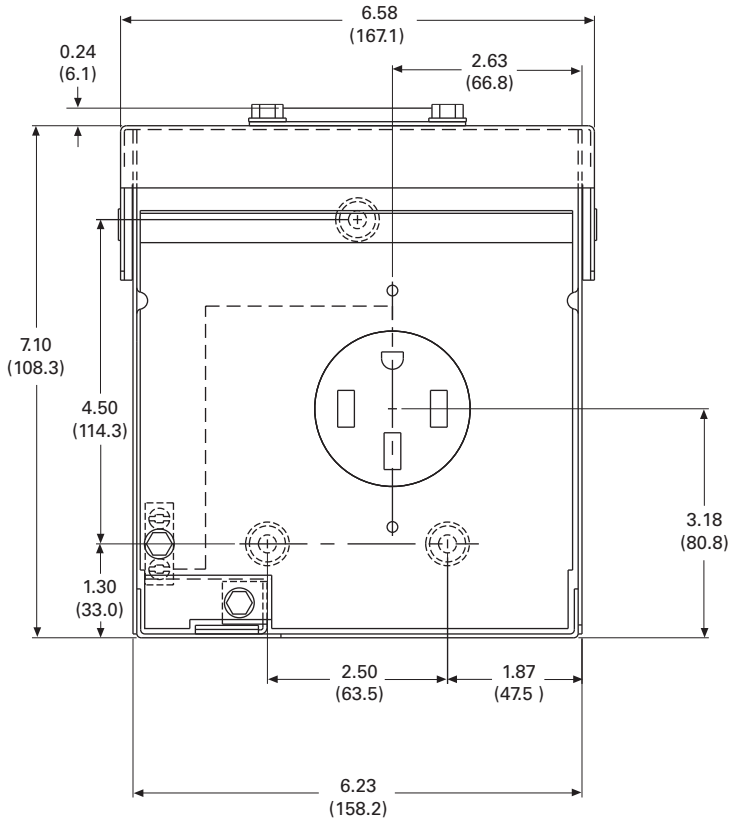

# 5.2

## Power Pedestals

### Temporary Power/RV Park

Approximate Dimensions in Inches (mm)

#### Compact Design Option

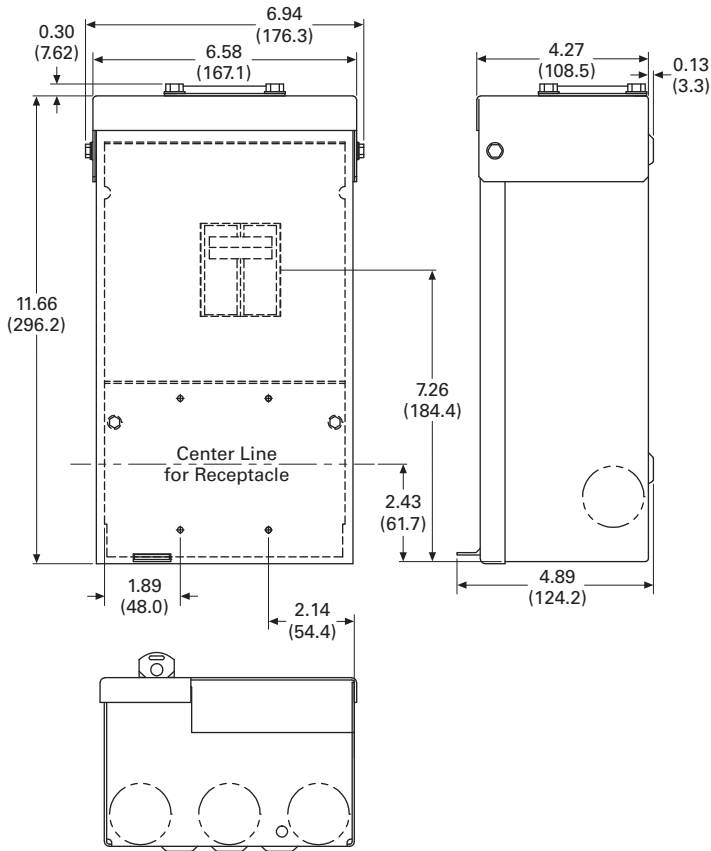

#### Unmetered Units

##### Unmetered Surface Type

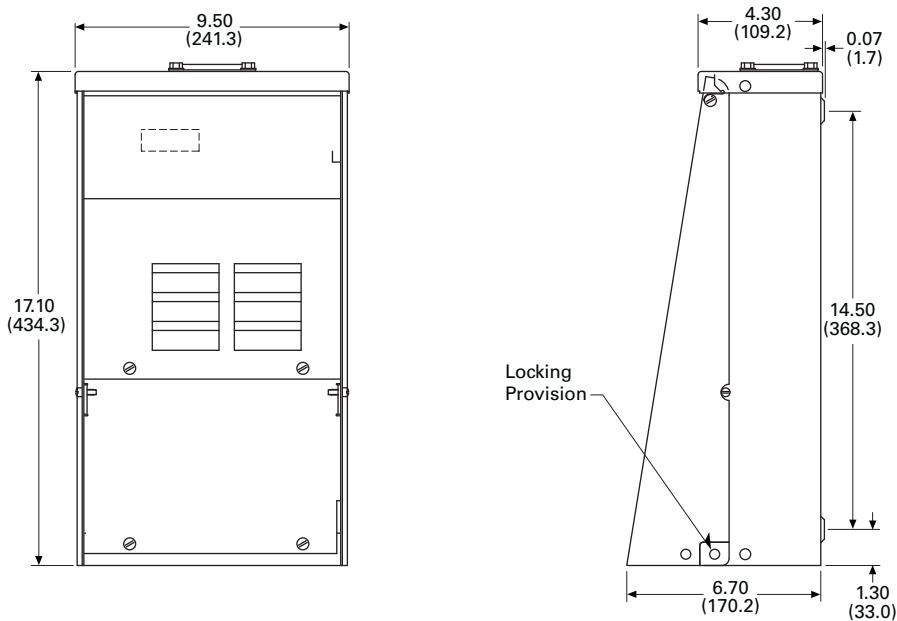



Approximate Dimensions in Inches (mm)

**Metered Units (Ring and Ringless)**

**Metered Surface Type**

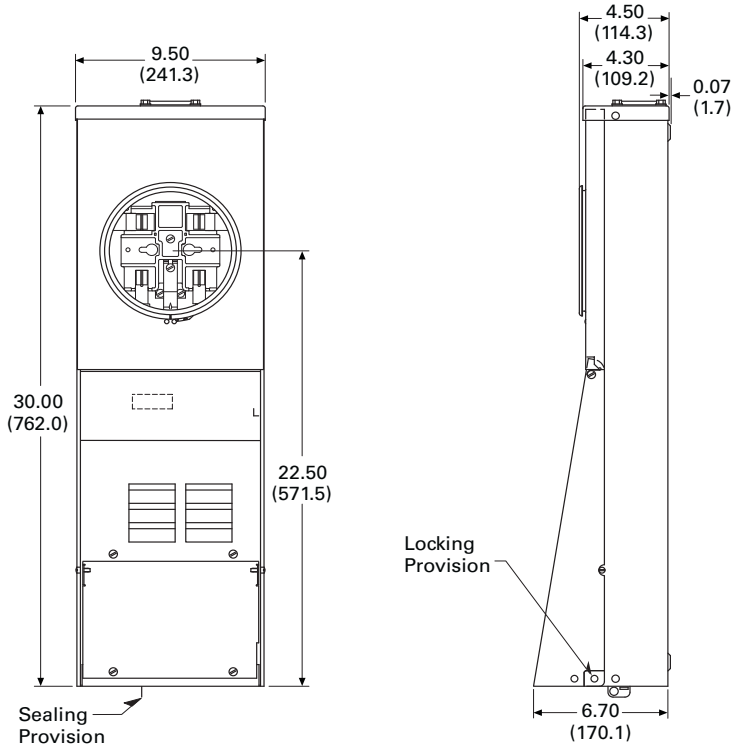

**Bottom Fed Type**

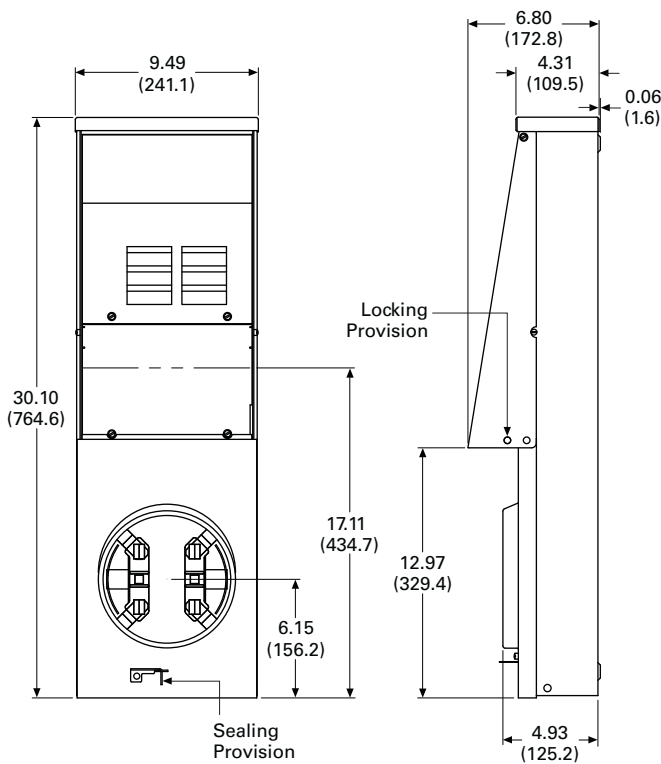

#### Power Outlet Panels



5

### Pedestal Units

#### Product Overview

A power outlet panel (or POP) is a device designed for outdoor service to meet temporary power requirements at construction sites and recreation vehicle (RV) parks. POPs provide a safe and reliable means for users to access electricity at such locations.

#### Product Selection

##### Power Outlet Panel Receptacle Configuration Rules

**Note:** All Power Outlet Panel Configurations using **NEMA 5-20R2** receptacles, including 2 and 6, must be paired with a ground fault breaker.

See **Page V1-T5-7** for complete list.

##### Four Receptacles/Unit

All receptacles must be NEMA 5-20R2 and/or NEMA 5-20R2GFI, surface mount only.

### Contents

#### Description

	<i>Page</i>
Product Overview . . . . .	<b>V1-T5-3</b>
Surface Units . . . . .	<b>V1-T5-10</b>
Pedestal Units . . . . .	<b>V1-T5-16</b>
Dimensions . . . . .	<b>V1-T5-18</b>

##### Three Receptacles/Unit

- One or more of the receptacles must be NEMA 6-20R2, NEMA 5-20R2 or NEMA 5-20R2GFI
- NEMA 6-20R2, NEMA 5-20R2, or NEMA 5-20R2GFI must go in the second position
- If two receptacles consist of types NEMA 14-50R, NEMA 10-50R, NEMA 14-30R or NEMA 6-20R2 a six-circuit interior must be added
  - Example:  
**CHUI5N2NSX**

##### Two, One and Zero Receptacles/Unit

Any configuration.

##### Options

- Six-circuit interior
- Factory-mounted pedestal extension
- Lighted
- Bottom fed

**Note:** Configuration 1 and 2 were chosen so a six-circuit interior needs to be added (suffix X) to the end of the catalog number. Also, configuration 5 is in the second position.

Unmetered Type



CHM1N7N4NPTZ



Pedestal Type

Ampere Series	Receptacle Description			Breaker Description			Catalog Number
	Position	Left	Center	Right	1st	2nd	
<b>Unmetered</b>							
50/30/20	14-50R	5-20R2GFI	TT-30R	Non-GFI	Non-GFI	Non-GFI	CHU1N7N4NP
30/20	TT-30R	5-20R2GFI	—	Non-GFI	Non-GFI	—	CHU4N7NP
50/30/20	14-50R	5-20R2GFI	TT-30R	Non-GFI	Non-GFI	Non-GFI	CHU1N7N4NPTZ
30/30/20	TT-30R	5-20R2GFI	TT-30R	Non-GFI	Non-GFI	Non-GFI	CHU4N7N4NP
30/20	TT-30R	5-20R2GFI	—	Non-GFI	Non-GFI	—	CHU4N7NPTZ
<b>Metered – Ring</b>							
50/30/20	14-50R	5-20R2GFI	TT-30R	Non-GFI	Non-GFI	Non-GFI	CHM1N7N4NP
50/20	14-50R	5-20R2GFI	—	Non-GFI	Non-GFI	—	CHM1N7NP
50/30/20	14-50R	5-20R2GFI	TT-30R	Non-GFI	Non-GFI	Non-GFI	CHM1N7N4NPTZ
30/20	TT-30R	5-20R2GFI	—	Non-GFI	Non-GFI	—	CHM4N7NPTZ
<b>Metered – Ringless</b>							
50/30/20	14-50R	5-20R2GFI	TT-30R	Non-GFI	Non-GFI	Non-GFI	CHR1N7N4NP
50/20/50	14-50R	5-20R2GFI	14-50R	Non-GFI	Non-GFI	Non-GFI	CHR1N7N1NPX
50/20/30	14-50R	5-20R2GFI	14-30R	Non-GFI	Non-GFI	Non-GFI	CHR1N7N3NPX
50/20/30	14-50R	5-20R2	14-30R	Non-GFI	Ground fault	Non-GFI	CHR1N6G3NPX

CHU1N7N4NBTZ



Back-to-Back Pedestal Type

Ampere Series	Receptacle Description			Breaker Description			Catalog Number
	Position	Left	Center	Right	1st	2nd	
<b>Unmetered</b> ①							
30/30/20	TT-30R	5-20R2GFI	TT-30R	Non-GFI	Non-GFI	Non-GFI	CHU4N7N4NB
50/30/20	14-50R	5-20R2GFI	TT-30R	Non-GFI	Non-GFI	Non-GFI	CHU1N7N4NBTZ
<b>Metered – Ring</b> ①							
30/20	TT-30R	5-20R2GFI	—	Non-GFI	Non-GFI	—	CHM4N7NB
50/30/20	14-50R	5-20R2GFI	TT-30R	Non-GFI	Non-GFI	Non-GFI	CHM1N7N4NB
<b>Metered – Ringless</b> ①							
50/30/20	14-50R	5-20R2GFI	TT-30R	Non-GFI	Non-GFI	Non-GFI	CHR1N7N4NBTZ

Notes

① The pedestal back-to-back units have receptacles and circuit breakers as shown for each panel and share one common pedestal with loop feed lugs. Contact your local Eaton sales office for configurations not listed.

Accessories

See Page V1-T5-7.

# 5.2

## Power Pedestals

### Temporary Power/RV Park

#### Dimensions

Approximate Dimensions in Inches (mm)

#### Metered Units

#### 100 A Pedestal

5

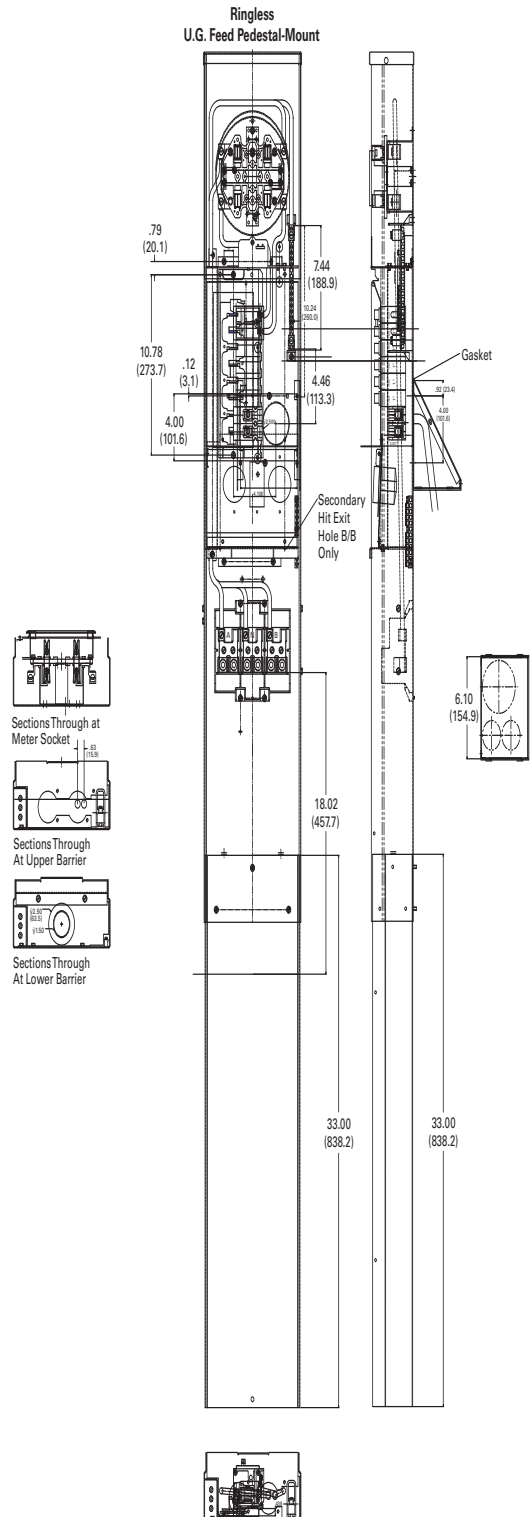

Approximate Dimensions in Inches (mm)

**Metered Units (Ring and Ringless)**

**Metered Back-to-Back Pedestal Type**

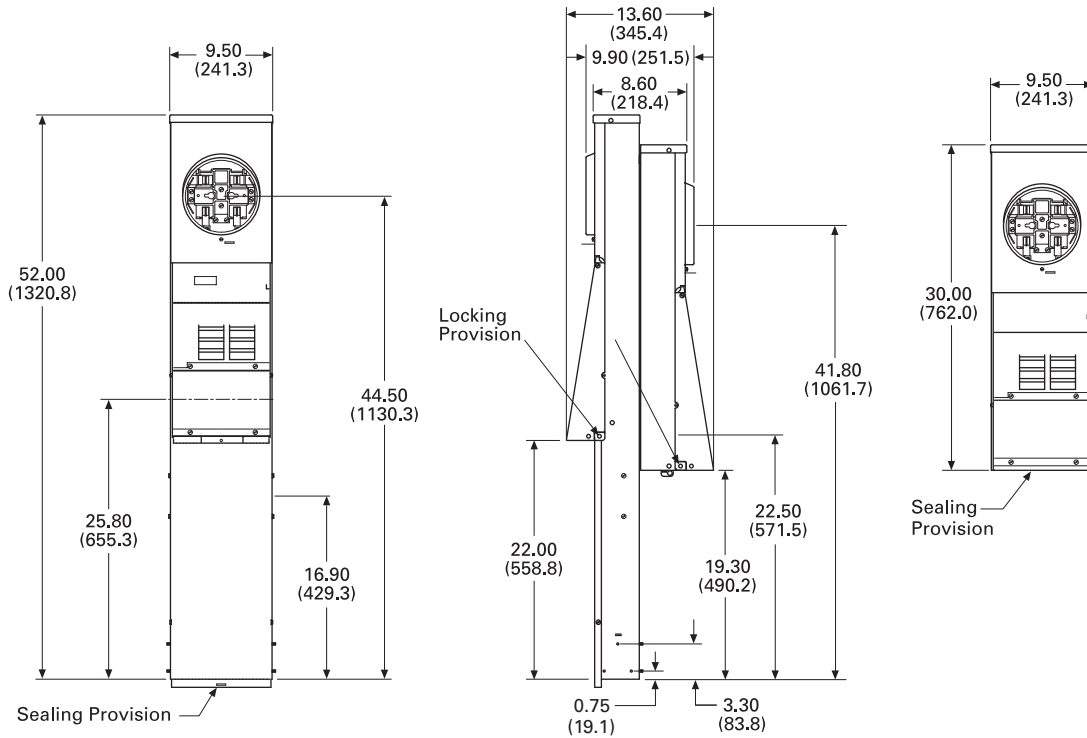

5

**Bottom Fed Type**

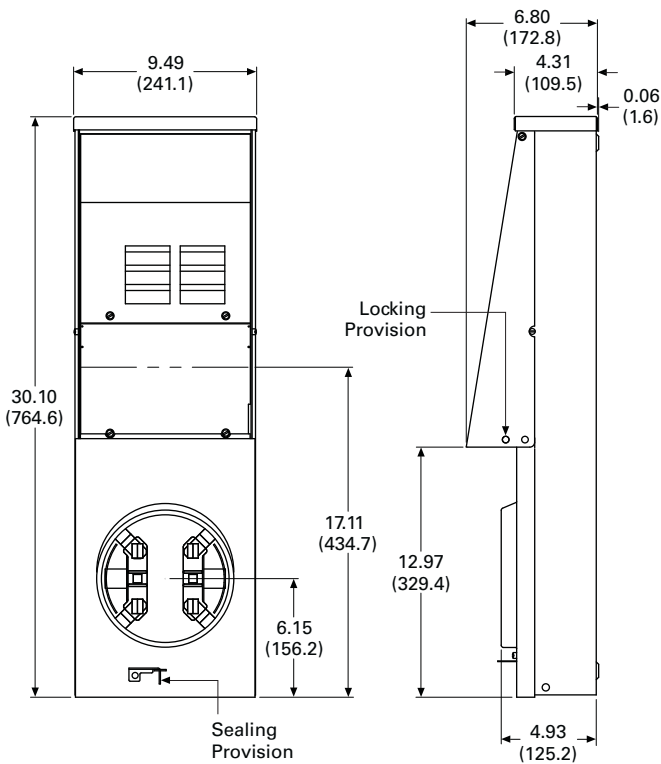

# 5.2

## Power Pedestals

### Temporary Power/RV Park

Approximate Dimensions in Inches (mm)

#### Unmetered Back-to-Back Pedestal Type

5

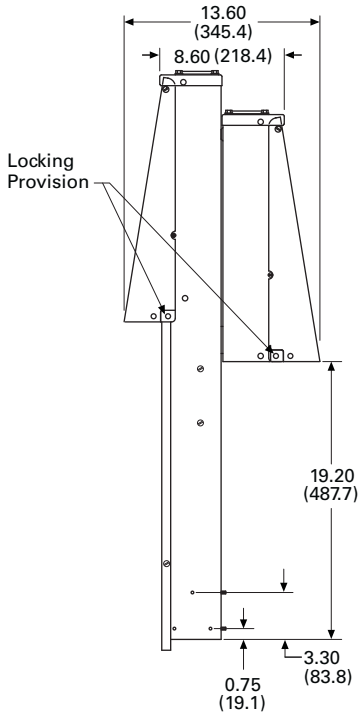

#### Unmetered Pedestal Type

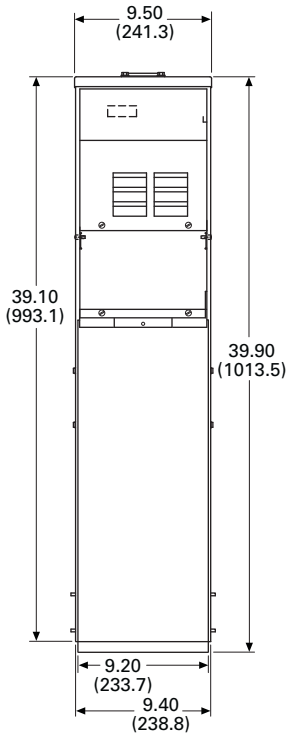

#### Metered Pedestal Type

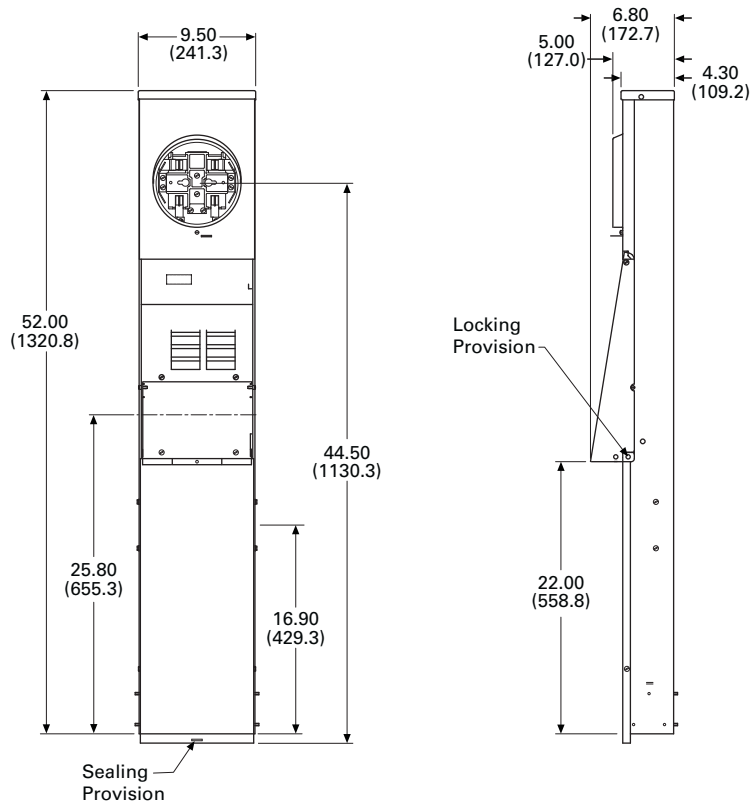

## Power Outlet Panels



### Product Overview

Eaton's versatile Mobile Home Panels have a user-friendly design that allows for a faster, cleaner installation.

100 and 200 A panels come complete with the main breaker and a 4/8 or 8/16 interior, respectively. The 200 A units are designed with ample width to ensure plenty of room for wire bending and an easier installation.

### Receptacle Deadfront Kits

Optional receptacle deadfront kits enable the field installation of contractor supplied receptacles and breakers that can supply power for a variety of applications including:

- Visiting RVs
- Temporary power
- Lawn equipment
- Air compressors
- Anything else that requires cord-connected power

### Contents

#### Description

	<i>Page</i>
Mobile Home Panels	
Catalog Number Selection . . . . .	<b>V1-T5-22</b>
Product Selection . . . . .	<b>V1-T5-22</b>
Accessories . . . . .	<b>V1-T5-23</b>
Dimensions . . . . .	<b>V1-T5-24</b>

### Features

#### Fastenerless Socket Design

- Eliminates overheating caused by loose socket connections

#### Pedestal Unit

- Convenient and sturdy ground mounting
- Loop feed feature allows several units to be connected in series

#### Easier, Better and Faster Installation

- More wire bending and viewing room
- Additional circuits mean more flexibility

### Catalog Number Selection

#### Mobile Home Panels

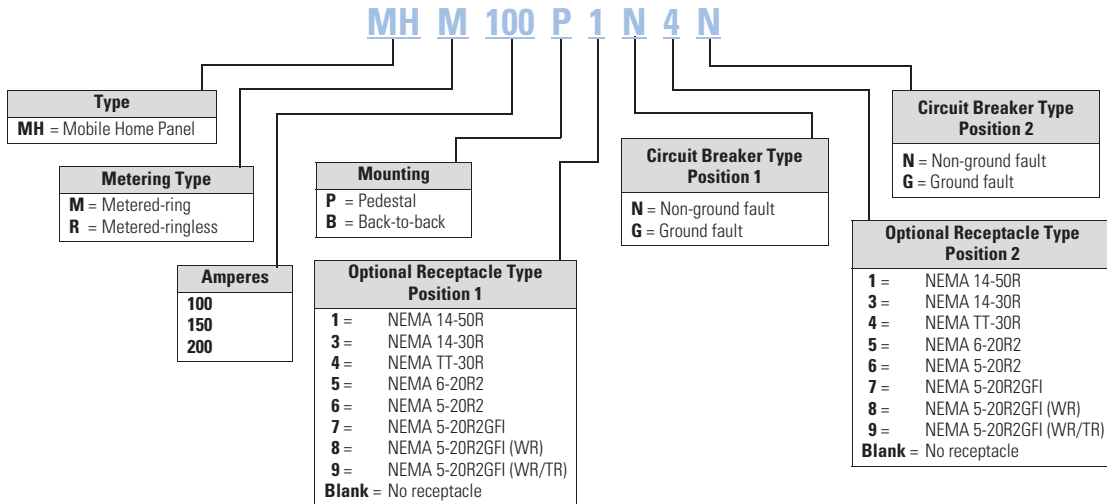

### Product Selection

#### Mobile Home Panels <sup>①</sup>























Amperes	Security	Interior	Main	Branch Breakers	Mounting	Receptacles	Catalog Number
100	Ring	4/8	<b>BR2100</b>	BR	Pedestal	None	<b>MHM100P</b>
100	Ring	4/8	<b>BR2100</b>	BR	Back-to-back	None	<b>MHM100B</b>
100	Ringless	4/8	<b>BR2100</b>	BR	Pedestal	None	<b>MHR100P</b>
100	Ringless	4/8	<b>BR2100</b>	BR	Back-to-back	None	<b>MHR100B</b>
150	Ring	8/16	<b>CSR2150</b>	BR	Pedestal	None	<b>MHM150P</b>
150	Ring	8/16	<b>CSR2150</b>	BR	Back-to-back	None	<b>MHM150B</b>
150	Ringless	8/16	<b>CSR2150</b>	BR	Pedestal	None	<b>MHR150P</b>
150	Ringless	8/16	<b>CSR2150</b>	BR	Back-to-back	None	<b>MHR150B</b>
200	Ring	8/16	<b>CSR2200</b>	BR	Pedestal	None	<b>MHM200P</b>
200	Ring	8/16	<b>CSR2200</b>	BR	Back-to-back	None	<b>MHM200B</b>
200	Ringless	8/16	<b>CSR2200</b>	BR	Pedestal	None	<b>MHR200P</b>
200	Ringless	8/16	<b>CSR2200</b>	BR	Back-to-back	None	<b>MHR200B</b>
200	Ringless	8/16	<b>CSR2200</b>	BR	Pedestal	Qty 1 14-50R Qty 2 TT-30R	<b>MHM200P1N4N4N</b>

**Note**

<sup>①</sup> Pedestal Extension included with Mobile Home Panels.



**Mobile Home Panel Deadfronts for 200 A Units** <sup>①</sup>**Available Receptacle Deadfront Kits—Receptacles and Breakers Not Included**

MHDX		MHDXZX	
MHDXX		MHDZZY	
MHDBLANK		MHDYZ	
MHDZ		MHDYZY	
MHDZZ		MHDXYX	
MHDZZZ		MHDXY Y	
MHDZZZZ		MHDXY	
MHDY		MHDXZY	
MHDYY		MHDXZ	
MHDYYY		MHDXZZ	
MHDYYYY			

**Accessories****Mobile Home Panels**

Hubs not used on mobile home panels.

Description	Amperes	Catalog Number
Direct feed kit	—	<b>MHDFK</b>
Pedestal extension	200	<b>MHPEEXT</b>
Stainless steel pedestal extension	200	<b>MHPEEXTSS</b>
Padmount adapter	200	<b>MHPAEXT</b>
Padmount adapter	100	<b>CHPAEXT100</b>

**Note**

<sup>①</sup> For 100 A units, the accessory Catalog Number would be MHD1\_\_\_\_. For example, to order a deadfront to accept one 30 A receptacle (round) in a 100 ampere device, the Catalog Number would be MHD1X.

# 5.3

## Power Pedestals

### Mobile Home Panels

#### Dimensions

Approximate Dimensions in Inches (mm)

#### Mobile Home Panel—Ringless—Pedestal Mounting

5

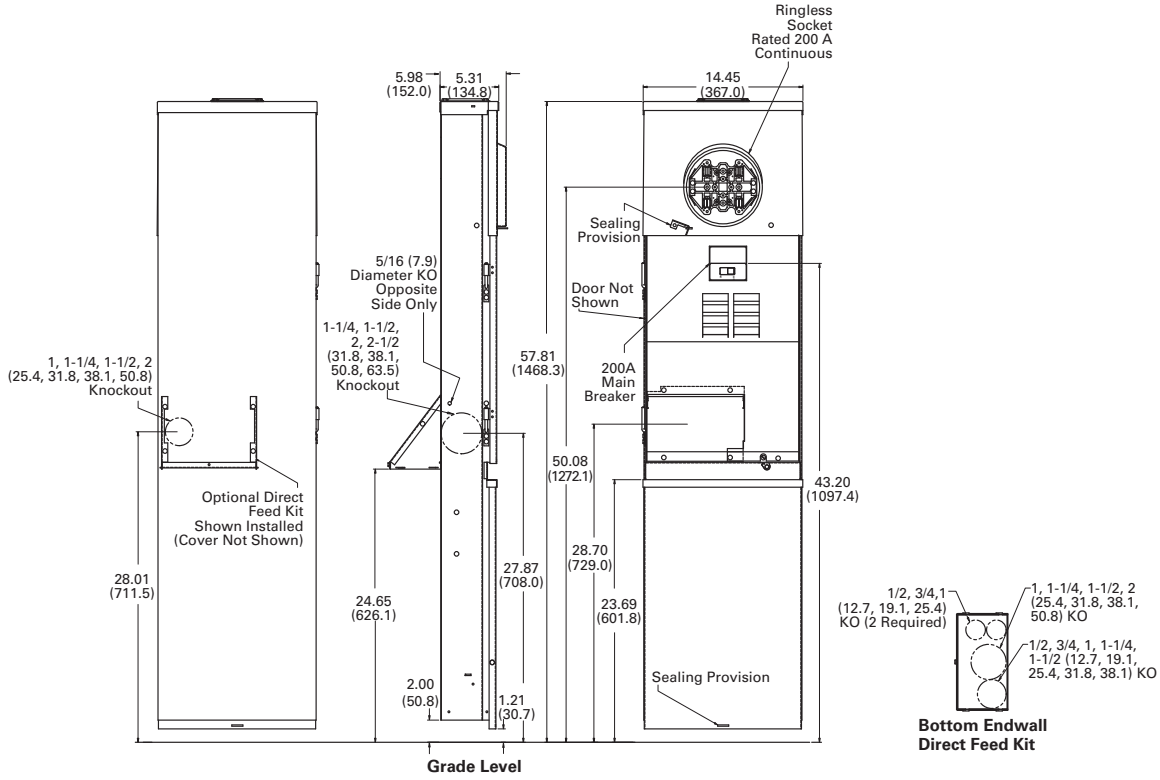

Approximate Dimensions in Inches (mm)

Mobile Home Panel—Ringless—Back-to-Back Mounting

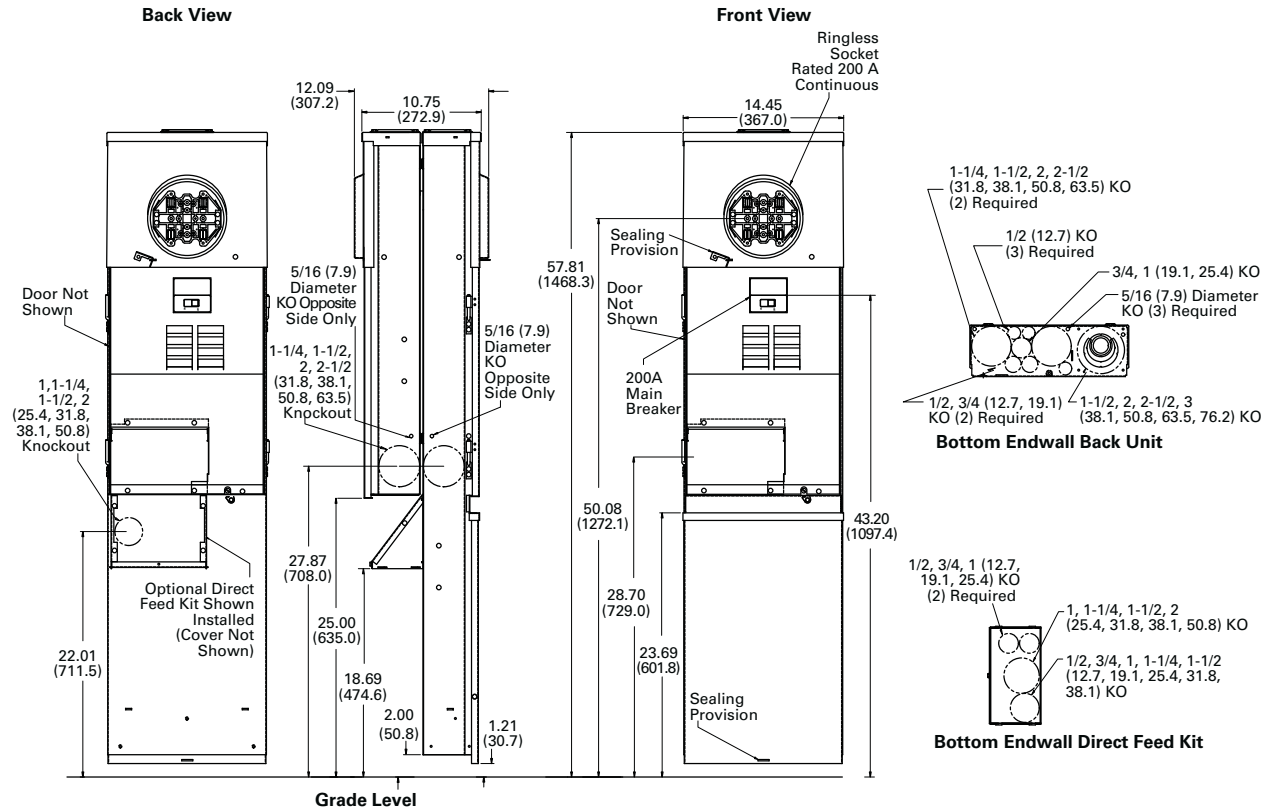

Approximate Dimensions in Inches (mm)

#### Mobile Home Panel—Ring—Pedestal Mounting

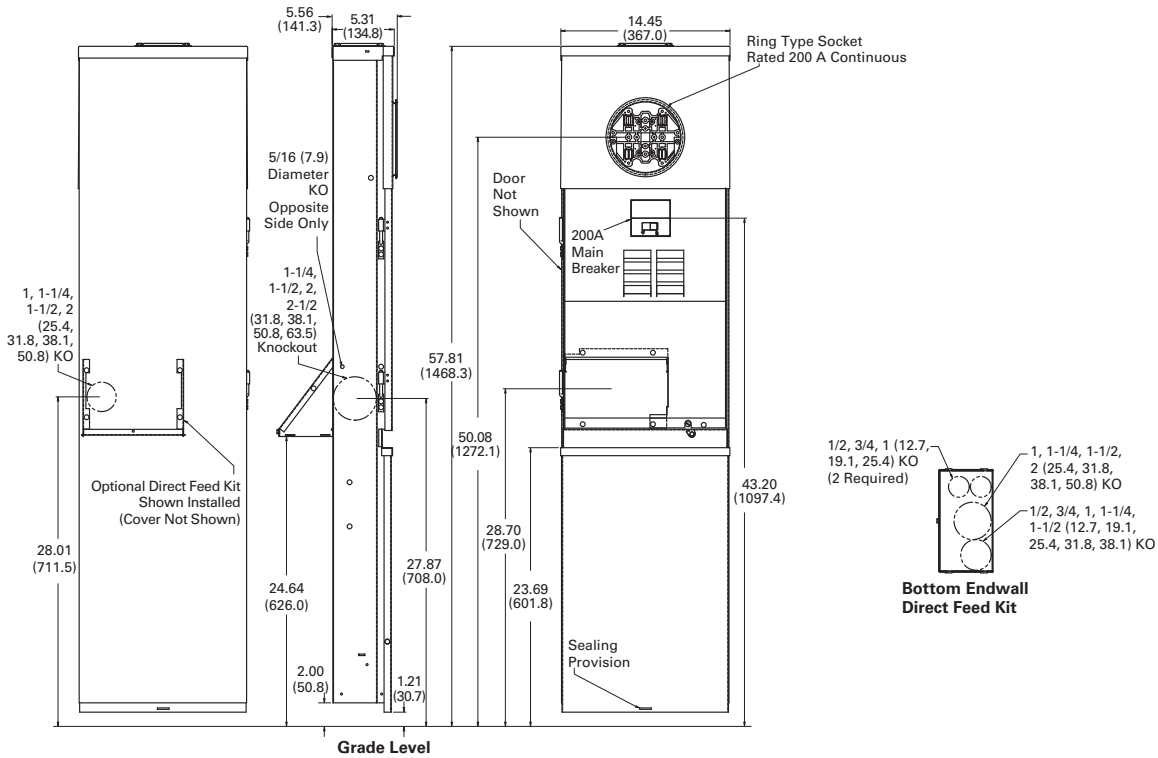

Approximate Dimensions in Inches (mm)

Mobile Home Panel—Ring—Back-to-Back Mounting

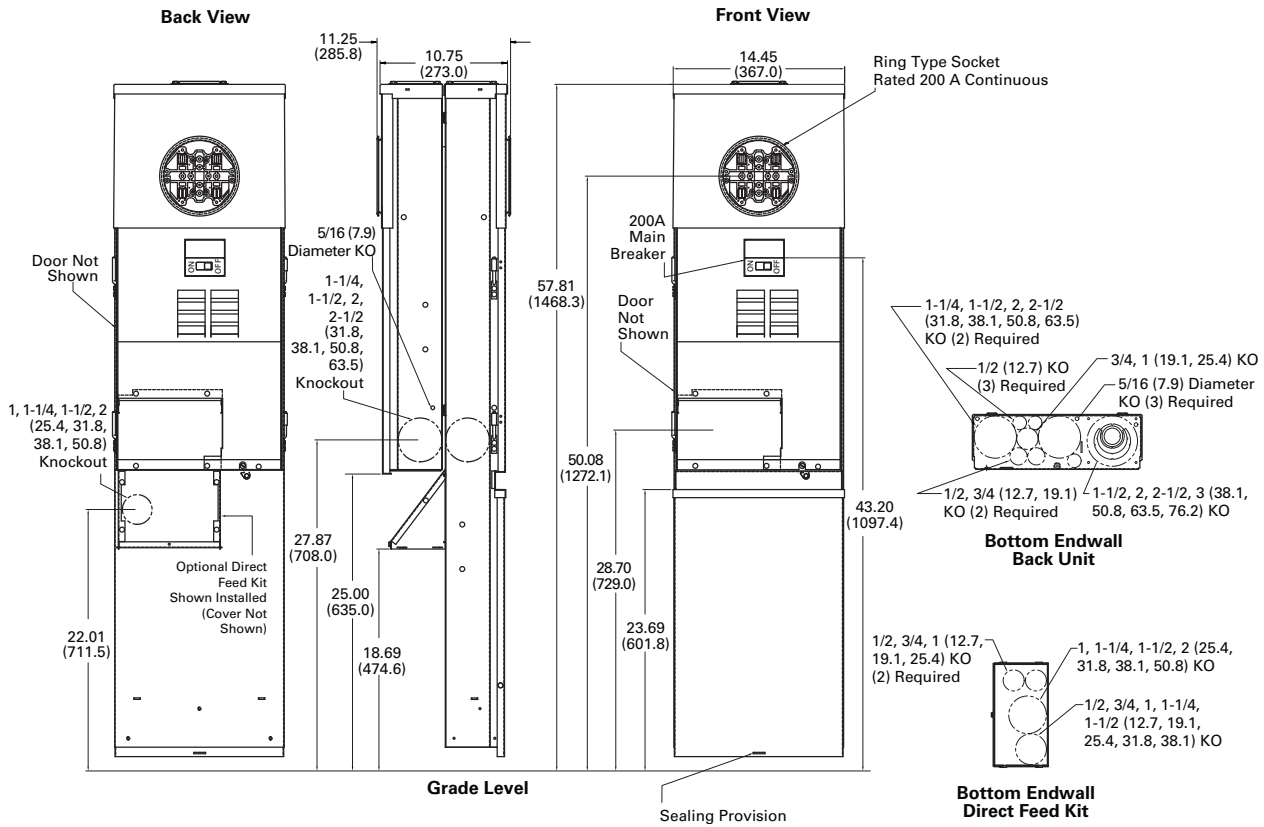

Recreational Vehicle/Campground Products



*High-Quality, Weatherproof Electrical Equipment*

5

### Power Pedestals

#### Product Overview

On March 24, 2006, RV Park Hook-Ups® joined together with Eaton to provide unmatched products and services in the recreational vehicle industry, as well as the marina industry. Known as the leader in electrical control, power distribution, and industrial automation products and services, Eaton is a quality driven company that constantly looks for ways to provide enhanced products and service solutions for their customers. Eaton will be able to provide RV park developers a complete electrical solution. For more information on the other products available from Eaton, visit us online at [www.eaton.com](http://www.eaton.com) or [www.rvparkhookups.com](http://www.rvparkhookups.com)

#### What Eaton has to Offer

- Complementary comprehensive in-house electrical designs for your complete RV or marina development
- RV and marina power pedestals
- Custom substations
- Transformers
- Panels
- Wire
- Digital electronic meters
- Receptacles and breakers
- Specialized electrical parts and equipment

### Contents

<i>Description</i>	<i>Page</i>
Power Pedestals	
Product Selection Guide . . . . .	<b>V1-T5-29</b>
Powerhouse Power Pedestal . . . . .	<b>V1-T5-30</b>
Powerhouse—Stainless Steel (SS) Power Pedestal . . . . .	<b>V1-T5-33</b>
Newport Camp Mate Power Pedestal . . . . .	<b>V1-T5-36</b>
Park Light Power Pedestal . . . . .	<b>V1-T5-39</b>
Firehouse . . . . .	<b>V1-T5-42</b>
Digital Electronic Kilowatthour Meters . . . . .	<b>V1-T5-44</b>
Distribution Equipment—Ground Fault Monitor . . . . .	<b>V1-T5-45</b>
Distribution Equipment—Substations. . . . .	<b>V1-T5-46</b>
Distribution Equipment—Panels. . . . .	<b>V1-T5-49</b>
Distribution Equipment—Transformers. . . . .	<b>V1-T5-50</b>

Product Selection Guide

Power Receptacles



Power Outlets		Phase	Maximum GFI	Powerhouse		
Side One	Side Two			Powerhouse	Powerhouse-SS	Newport Camp Mate
None	None	1	2	2	2	2
30-20	00	1	2	2	1	1
30-20	30-20	1	2	2	—	—
30-30-20	30-30-20	1	2	2	—	—
30-20	50-20	1	2	2	—	—
30-30-20	50-20	1	2	2	—	—
30-30-20	30-50-20	1	2	2	—	—
30-30-20	50-50-20	1	2	2	—	—
30-50-20	30-50-20	1	2	2	—	—
30-50-20	50-50-20	1	2	2	—	—
50-20	None	1	2	2	—	—
50-20	50-20	1	2	2	—	—
50-50-20	50-20	1	2	2	—	—
50-50-20	50-50-20	1	2	2	—	—
30-50-20	None	1	2	2	0	—

#### Powerhouse Power Pedestal



5

### Powerhouse Power Pedestal

#### Product Description

The Powerhouse® RV utility center is our most popular pedestal for single or double RV sites because of its full complement of standard features and available option packages able to meet any user requirement. The housing is made of durable weatherproof engineered resin and will never rust or deteriorate.

That's why it comes with a limited lifetime warranty. Since the Powerhouse can accommodate two RV sites, it's an economical pedestal for double site installation. This unit is ideal for new, or when retrofitting, full-service RV parks.

#### Features

- Photocell controlled 13 watt fluorescent light with amber lens
- Lockable weatherproof doors that protect receptacles and breakers
- Hose and cable brackets
- Engineered resin housing with a two-part polyurethane coating for a UV-resistant, long-lasting finish
- Limited lifetime warranty on the housing
- Loop-feed mechanical busbars that can accept up to 250 kcmil wire
- Hinged pedestal base providing easy access for installation and maintenance

### Contents

#### Description

<i>Description</i>	<i>Page</i>
Power Pedestals . . . . .	<b>V1-T5-28</b>
Powerhouse Power Pedestal	
Standards and Certifications . . . . .	<b>V1-T5-31</b>
Catalog Number Selection . . . . .	<b>V1-T5-31</b>
Accessories . . . . .	<b>V1-T5-32</b>
Dimensions . . . . .	<b>V1-T5-32</b>
Powerhouse—Stainless Steel (SS) Power Pedestal	<b>V1-T5-33</b>
Newport Camp Mate Power Pedestal . . . . .	<b>V1-T5-36</b>
Park Light Power Pedestal . . . . .	<b>V1-T5-39</b>
Firehouse . . . . .	<b>V1-T5-42</b>
Digital Electronic Kilowatthour Meters . . . . .	<b>V1-T5-44</b>
Distribution Equipment—Ground Fault Monitor . .	<b>V1-T5-45</b>
Distribution Equipment—Substations. . . . .	<b>V1-T5-46</b>
Distribution Equipment—Panels. . . . .	<b>V1-T5-49</b>
Distribution Equipment—Transformers. . . . .	<b>V1-T5-50</b>

#### Available Options

- Clear lens
- Photocell controlled single or dual 7 watt or 13 watt fluorescent light
- Telephone (RJ-11) for each side
- Cable TV for each side
- High-speed Internet connector (RJ-45) for each side
- Water—single or dual 1/4-turn brass ball valves (brass "T" connection) with 3/4-inch hose bibs
- Water meters with remote capability
- Water—anti-siphon faucet
- Loop-feed 3/8-inch stud lug copper busbar for up to 250 kcmil wire (recommended for salt water environments)
- Single-feed mechanical busbars for up to 250 kcmil wire
- Digital electronic meter for each side
- Wireless remote reading of electronic kilowatt meters
- Meter socket for each side powered (to accept glass style meter)
- Direct burial ground mounting stand stainless or galvanized
- Custom paint color

#### Surge Protection

SurgeTrap is designed to protect electrical and electronic loads from transients and surge disturbances on your AC power line, such as voltage surges, spikes and lightning. The SurgeTrap has a lifetime warranty where Eaton will replace the SurgeTrap device at no charge.

- 175 kA maximum surge current
- 3500 joules
- Type 3R enclosure
- Comes with a protection working indicator light
- Factory installed integral to pedestal or available for retrofit



**Standards and Certifications**

- UL/CSA listed



**Catalog Number Selection**

P D U 4 7 0 0 0 0 0 1 2 K M

**Type**

**P** = Powerhouse  
**Z** = PHSS

**Lighting and Lens Color**

<b>A</b>	= 7 W light	Amber
<b>B</b>	= Dual 7 W light	Amber
<b>C</b>	= 9 W light	Amber
<b>D</b>	= 13 W light	Amber
<b>E</b>	= Dual 13 W light	Amber
<b>F</b>	= No lighting	Amber
<b>G</b>	= 7 W light	Clear
<b>H</b>	= Dual 7 W light	Clear
<b>I</b>	= 9 W light	Clear
<b>J</b>	= 13 W light	Clear
<b>K</b>	= Dual 13 W light	Clear
<b>L</b>	= No lighting	Clear
<b>M</b>	= 7 W light	Special
<b>N</b>	= Dual 7 W light	Special
<b>O</b>	= 9 W light	Special
<b>P</b>	= 13 W light	Special
<b>Q</b>	= Dual 13 W light	Special
<b>R</b>	= No lighting	Special
<b>S</b>	= 350 MA LED	Amber
<b>T</b>	= 700 MA LED	Amber
<b>U</b>	= 350 MA LED	Clear
<b>V</b>	= 700 MA LED	Clear
<b>W</b>	= 350 MA LED	Special
<b>Y</b>	= 700 MA LED	Special

**Metering Type**

**U** = Unmetered  
**D** = Digital electronic meters (side one)  
**T** = Digital electronic meters (side two)  
**B** = Digital electronic meters (both sides)  
**R** = Receptacles metered individually  
**M** = One meter socket (100 A)  
**N** = Two meter socket (100 A each)

**Sides and Receptacles**

	R1S1	R2S1	R3S1	R4S1	R1S2	R2S2	R3S2	R4S2
<b>0</b>	0	0	0	0	0	0	0	0
<b>1</b>	1	1	1	1	1	1	1	1
<b>2</b>	2	2	2	2	2	2	2	2
<b>3</b>	3	3	3	3	3	3	3	3
<b>4</b>	4	4	4	4	4	4	4	4
<b>5</b>	5	5	5	5	5	5	5	5
<b>6</b>	6	6	6	6	6	6	6	6
<b>7</b>	7	7	7	7	7	7	7	7
<b>8</b>	8	8	8	8	8	8	8	8

**Water Option** ①

**0** = 0  
**1** = 1  
**2** = 2  
**3** = Single water meter  
**4** = Dual water meter  
**5** = Single meter, 2 V  
**6** = 1 frost free  
**7** = 2 frost free

**Extra Unmetered GFI Receptacles**

**0** = None  
**1** = 1  
**2** = 2

**Phone Cable TV and Internet Options**

	Phone Jack	Cable TV Jack	Internet Option
<b>A</b>	= 1	0	0
<b>B</b>	= 1	0	1
<b>C</b>	= 1	0	2
<b>D</b>	= 1	1	0
<b>E</b>	= 1	1	1
<b>F</b>	= 1	1	2
<b>G</b>	= 1	2	0
<b>H</b>	= 1	2	1
<b>I</b>	= 1	2	2
<b>J</b>	= 2	0	0
<b>K</b>	= 2	0	1
<b>L</b>	= 2	0	2
<b>M</b>	= 2	1	0
<b>N</b>	= 2	1	1
<b>O</b>	= 2	1	2
<b>P</b>	= 2	2	0
<b>Q</b>	= 2	2	1
<b>R</b>	= 2	2	2
<b>S</b>	= 0	2	2
<b>T</b>	= 0	0	1
<b>U</b>	= 0	0	2
<b>V</b>	= 0	1	0
<b>W</b>	= 0	1	1
<b>X</b>	= 0	1	2
<b>Y</b>	= 0	2	0
<b>Z</b>	= 0	2	1
<b>0</b>	= 0	0	0

**Bus**

**S** = Single-phase 3/8-inch copper busbar  
**F** = Three-phase 3/8-inch copper busbar  
**C** = Single-phase 3/8-inch Canadian busbar  
**T** = Three-phase 3/8-inch Canadian busbar  
**M** = Single-phase 300 kcmil mechanical lug bus  
**Z** = Three-phase 300 kcmil mechanical lug bus  
**L** = Single-phase 350 kcmil mechanical lug bus  
**P** = Three-phase 350 kcmil mechanical lug bus  
**N** = Single-phase 1/4-inch copper busbar  
**Q** = Single-phase 1/4-inch split mechanical busbar  
**A** = Single-phase 300 kcmil mechanical lug Canadian bus  
**B** = Three-phase 300 kcmil mechanical lug Canadian bus  
**D** = Single-phase 350 kcmil mechanical lug Canadian bus  
**E** = Three-phase 350 kcmil mechanical lug Canadian bus

Receptacle: R1S1 = Receptacle 1, Side 1  
 R2S1 = Receptacle 2, Side 1  
 R3S1 = Receptacle 3, Side 1  
 R1S2 = Receptacle 1, Side 2  
 R2S2 = Receptacle 2, Side 2  
 R3S2 = Receptacle 3, Side 2

**Notes**

- ① Number represents the quantity of 1/4-turn ball valves with 3/4-inch hose bibs.
- Internet option also available. Contact factory for details.

# 5.4

## Power Pedestals

### RV Park Hook-Ups

#### Accessories

See Page V1-T5-75.

#### Dimensions

Approximate Dimensions in Inches (mm)

#### Powerhouse

5

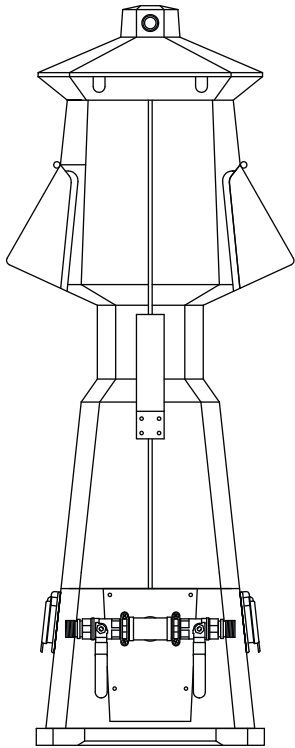

Side View

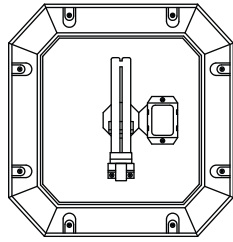

Top

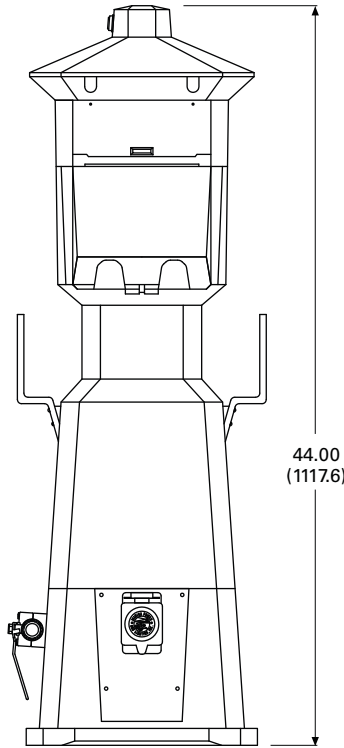

Front View

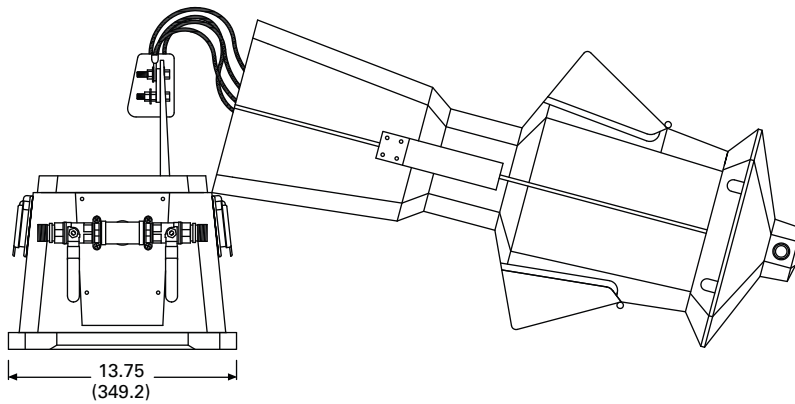

Broken View

**Powerhouse—Stainless Steel (SS) Power Pedestal****Powerhouse—Stainless Steel (SS) Power Pedestal****Product Description**

For long-lasting durability and low maintenance, the new stainless steel Powerhouse—SS pedestal is the most resilient power center offered.

We have designed a stainless steel pedestal that will meet and exceed all applicable codes and withstand harsh inland and coastal environments.

**Features**

- Stainless steel housing with a limited lifetime warranty
- Photocell controlled 13 watt fluorescent light with amber lens
- Large removable access panel for easy installation and maintenance
- Weatherproof doors that protect receptacles and breakers
- Backlit faceplate to aid in hooking up at night
- Hose and cable brackets
- Powder-coated finish
- Loop-feed mechanical busbars that can accept up to 350 kcmil wire

**Contents****Description**

	<b>Page</b>
Power Pedestals . . . . .	<b>V1-T5-28</b>
Powerhouse Power Pedestal . . . . .	<b>V1-T5-30</b>
Powerhouse—Stainless Steel (SS) Power Pedestal	
Catalog Number Selection . . . . .	<b>V1-T5-34</b>
Accessories . . . . .	<b>V1-T5-35</b>
Dimensions . . . . .	<b>V1-T5-35</b>
Newport Camp Mate Power Pedestal . . . . .	<b>V1-T5-36</b>
Park Light Power Pedestal . . . . .	<b>V1-T5-39</b>
Firehouse . . . . .	<b>V1-T5-42</b>
Digital Electronic Kilowatt-hour Meters . . . . .	<b>V1-T5-44</b>
Distribution Equipment—Ground Fault Monitor . . . . .	<b>V1-T5-45</b>
Distribution Equipment—Substations . . . . .	<b>V1-T5-46</b>
Distribution Equipment—Panels . . . . .	<b>V1-T5-49</b>
Distribution Equipment—Transformers . . . . .	<b>V1-T5-50</b>

**Available Options**

- Clear lens
- Photocell controlled single or dual 7 watt or 13 watt fluorescent light
- Telephone (RJ-11) for each side
- Cable TV for each side
- High-speed Internet connection (RJ-45) for each side
- Water—single or dual 1/4-turn brass ball valves (brass “T” connection) with 3/4-inch hose bibs
- Water meters with remote capability
- Water—anti-siphon faucet
- Direct burial stainless steel ground mounting stand
- Lockable doors
- Loop-feed 3/8-inch stud lug copper busbar for up to 350 kcmil wire (recommended for salt water environments)
- Single-feed mechanical busbars for up to 350 kcmil wire
- Digital electronic metering for each side
- Wireless remote reading of electronic kilowatt meters
- Meter socket for each side powered (to accept glass style meter)
- Four door design to add more outlets per pedestal

#### Catalog Number Selection

Z D U 4 7 0 0 0 0 0 1 2 K M

Type
P = Powerhouse
Z = PHSS

Lighting and Lens Color	
A	7 W light Amber
B	Dual 7 W light Amber
C	9 W light Amber
D	13 W light Amber
E	Dual 13 W light Amber
F	No lighting Amber
G	7 W light Clear
H	Dual 7 W light Clear
I	9 W light Clear
J	13 W light Clear
K	Dual 13 W light Clear
L	No lighting Clear
M	7 W light Special
N	Dual 7 W light Special
O	9 W light Special
P	13 W light Special
Q	Dual 13 W light Special
R	No lighting Special
S	350 MA LED Amber
T	700 MA LED Amber
U	350 MA LED Clear
V	700 MA LED Clear
W	350 MA LED Special
Y	700 MA LED Special

Metering Type	
U	Unmetered
D	Digital electronic meters (side one)
T	Digital electronic meters (side two)
B	Digital electronic meters (both sides)
R	Receptacles metered individually
M	One meter socket (100 A)
N	Two meter socket (100 A each)

Sides and Receptacles							
R1S1	R2S1	R3S1	R4S1	R1S2	R2S2	R3S2	R4S2
0	0	0	0	0	0	0	0
1	1	1	1	1	1	1	1
2	2	2	2	2	2	2	2
3	3	3	3	3	3	3	3
4	4	4	4	4	4	4	4
5	5	5	5	5	5	5	5
6	6	6	6	6	6	6	6
7	7	7	7	7	7	7	7
8	8	8	8	8	8	8	8

**0** = None  
**1** = 20 A GFI duplex  
**2** = 30 A, 125 V  
**4** = 50 A, 125/250 V  
**5** = 100 A, 208 V  
**6** = 100 A, 250 V  
**7** = 100 A, 277/480 V  
**8** = 100 A, 480 V

Water Option <sup>①</sup>	
0	= 0
1	= 1
2	= 2
3	= Single water meter
4	= Dual water meter
5	= Single meter, 2 V
6	= 1 frost free
7	= 2 frost free

Extra Unmetered GFI Receptacles	
0	= None
1	= 1
2	= 2

Phone Cable TV and Internet Options		
Phone Jack	Cable TV Jack	Internet Option
A	= 1	0
B	= 1	0
C	= 1	0
D	= 1	1
E	= 1	1
F	= 1	1
G	= 1	2
H	= 1	2
I	= 1	2
J	= 2	0
K	= 2	0
L	= 2	0
M	= 2	1
N	= 2	1
O	= 2	1
P	= 2	2
Q	= 2	2
R	= 2	2
S	= 0	2
T	= 0	0
U	= 0	0
V	= 0	1
W	= 0	1
X	= 0	1
Y	= 0	2
Z	= 0	2
0	= 0	0

Bus	
S	= Single-phase 3/8-inch copper busbar
F	= Three-phase 3/8-inch copper busbar
C	= Single-phase 3/8-inch Canadian busbar
T	= Three-phase 3/8-inch Canadian busbar
M	= Single-phase 300 kcmil mechanical lug bus
Z	= Three-phase 300 kcmil mechanical lug bus
L	= Single-phase 350 kcmil mechanical lug bus
P	= Three-phase 350 kcmil mechanical lug bus
N	= Single-phase 1/4-inch copper busbar
Q	= Single-phase 1/4-inch split mechanical busbar
A	= Single-phase 300 kcmil mechanical lug Canadian bus
B	= Three-phase 300 kcmil mechanical lug Canadian bus
D	= Single-phase 350 kcmil mechanical lug Canadian bus
E	= Three-phase 350 kcmil mechanical lug Canadian bus

Receptacle: R1S1 = Receptacle 1, Side 1  
 R2S1 = Receptacle 2, Side 1  
 R3S1 = Receptacle 3, Side 1  
 R1S2 = Receptacle 1, Side 2  
 R2S2 = Receptacle 2, Side 2  
 R3S2 = Receptacle 3, Side 2

#### Notes

<sup>①</sup> Number represents the quantity of 1/4-turn ball valves with 3/4-inch hose bibs.  
 Internet option also available. Contact factory for details.

**Accessories**

See **Page V1-T5-75**.

**Dimensions**

Approximate Dimensions in Inches (mm)

**Powerhouse—Stainless Steel (SS)**

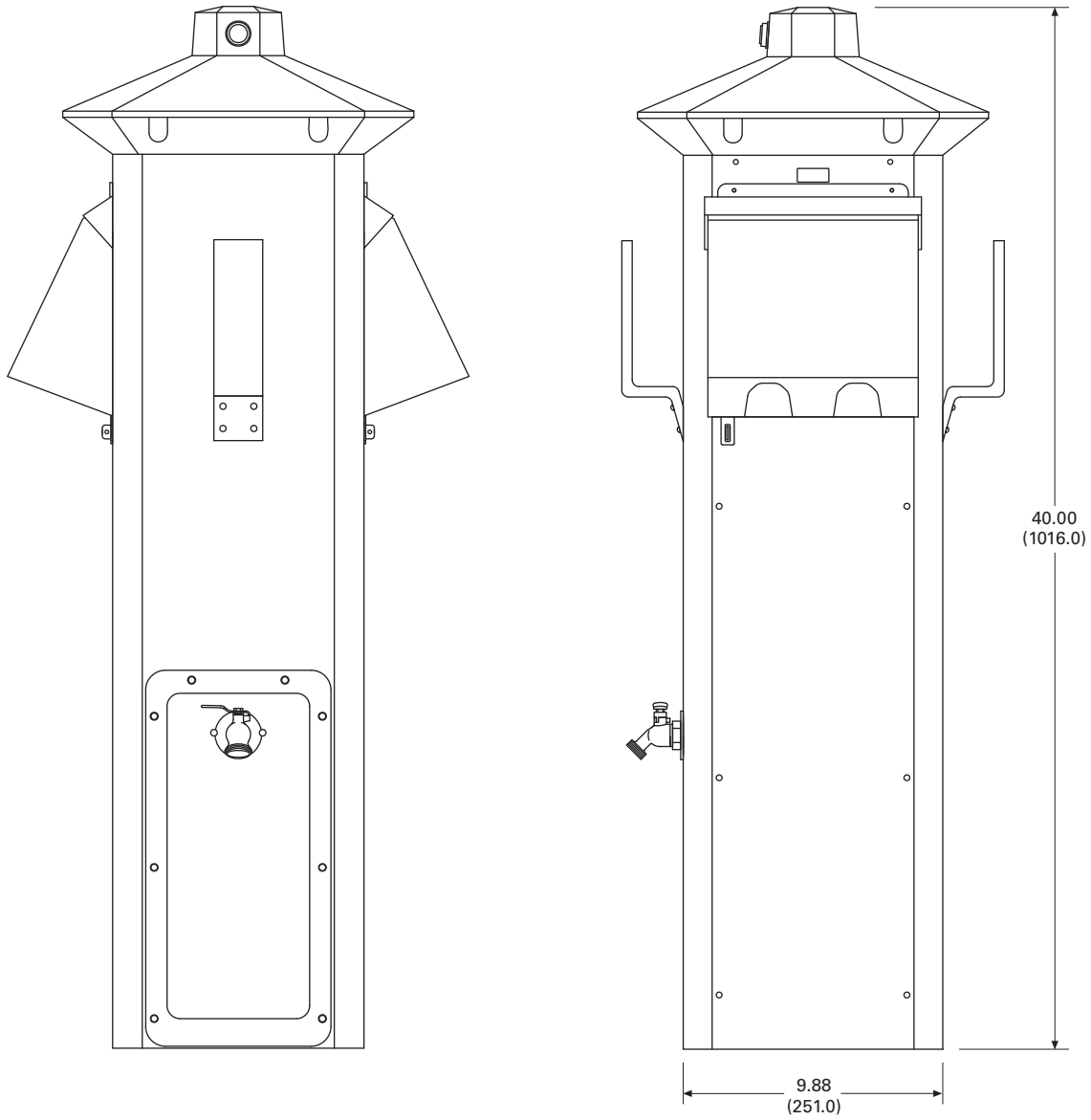

Newport Camp Mate Power Pedestal



5

### Newport Camp Mate Power Pedestal

#### Product Description

The Newport Camp Mate provides many of the features and options of our other full-size pedestals, but in a compact self-contained unit. This model provides more mounting options to RV park owners than any other model. It can be mounted to our stainless steel stand either flanged or direct burial, a post or any wall.

It comes standard with a resin housing that will never rust or deteriorate and provides area lighting as well as aiding in hooking up at night. This unit is especially suitable to many RV park renovation projects as well as new RV parks.

#### Features

- Photocell controlled 7 watt fluorescent light with amber lens
- Lockable weatherproof door that protects receptacles and breakers
- Engineered resin housing
- Limited lifetime warranty on the housing
- Designed to mount on a post, wall or an optional custom stand
- Loop-feed 1/4-inch copper stud lug busbars that can accept 2/0 AWG wire for Camp Mate without optional stand
- Loop-feed mechanical busbars that can accept up to 2/0 AWG wire for Camp Mate on optional stand

### Contents

#### Description

	<i>Page</i>
Power Pedestals . . . . .	<b>V1-T5-28</b>
Powerhouse Power Pedestal . . . . .	<b>V1-T5-30</b>
Powerhouse—Stainless Steel (SS) Power Pedestal . . . . .	<b>V1-T5-33</b>
Newport Camp Mate Power Pedestal	
Catalog Number Selection . . . . .	<b>V1-T5-37</b>
Accessories . . . . .	<b>V1-T5-38</b>
Dimensions . . . . .	<b>V1-T5-38</b>
Park Light Power Pedestal . . . . .	<b>V1-T5-39</b>
Firehouse . . . . .	<b>V1-T5-42</b>
Digital Electronic Kilowatthour Meters . . . . .	<b>V1-T5-44</b>
Distribution Equipment—Ground Fault Monitor . . . . .	<b>V1-T5-45</b>
Distribution Equipment—Substations . . . . .	<b>V1-T5-46</b>
Distribution Equipment—Panels . . . . .	<b>V1-T5-49</b>
Distribution Equipment—Transformers . . . . .	<b>V1-T5-50</b>

#### Available Options

- 36-inch stainless steel stand
- 40-inch stainless steel pad-mounted stand
- 60-inch direct burial stainless steel stand
- Telephone (RJ-11)
- Cable TV
- High-speed Internet connector (RJ-45)
- Water—single or dual 1/4-turn brass ball valves (brass “T” connection) with 3/4-inch hose bibs mounted on optional stand
- Water—anti-siphon backflow preventer
- Loop feed 3/8-inch stud lug copper busbar for up to 350 kcmil wire with stand (recommended for salt water environments)
- Single-feed mechanical busbars for up to 350 kcmil wire available with stand
- Digital electronic meter
- Wireless remote reading of electronic kilowatt meter
- Meter socket available with aluminum stands (to accept glass style meter)

#### Standards and Certifications

The Newport Camp Mate is UL listed and comes with a limited lifetime warranty on the housing.



Catalog Number Selection

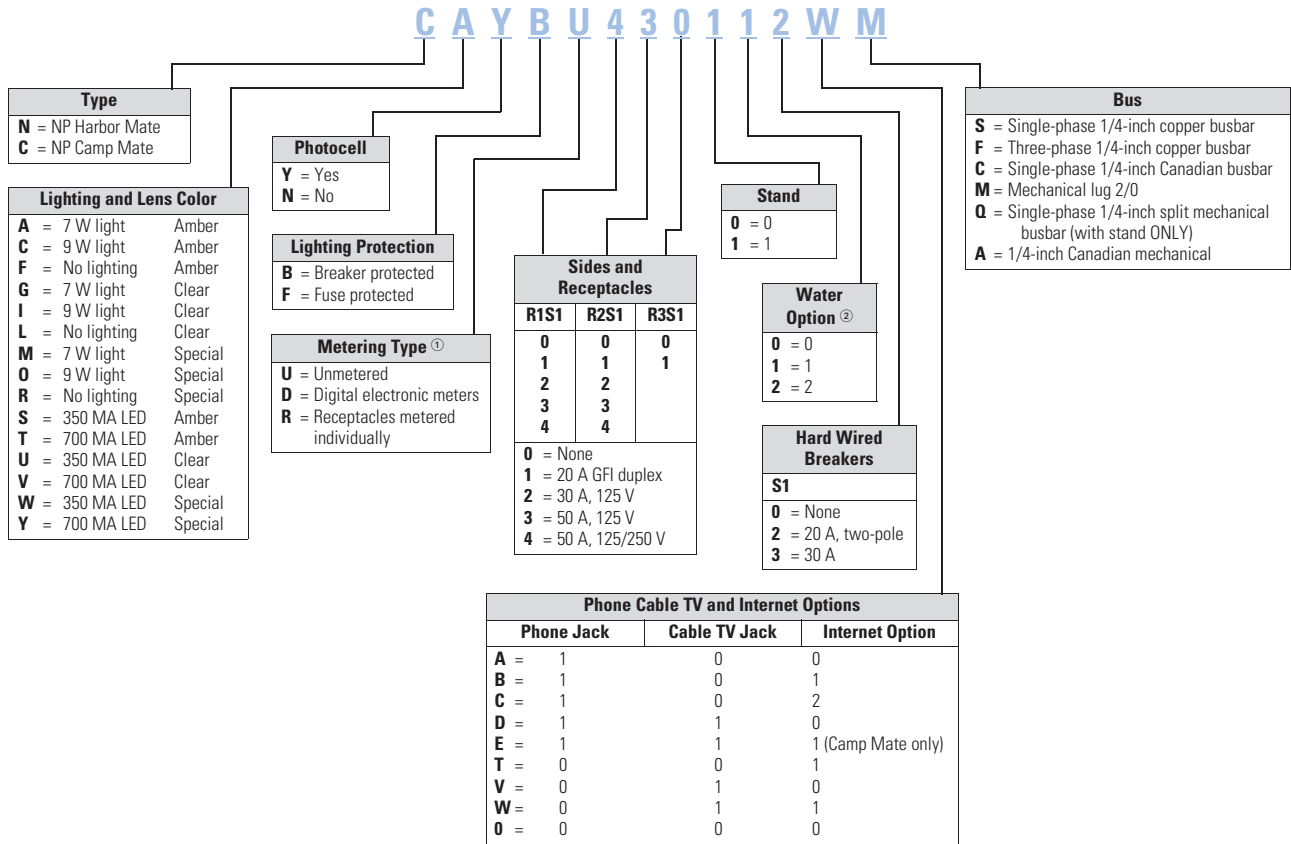

Receptacle: R1 = Receptacle 1  
R2 = Receptacle 2  
R3 = Receptacle 3

**Notes**

- ① 20 A GFIs not metered.
- ② Number represents the quantity of 1/4-turn ball valves with 3/4-inch hose bibs (with stand only).

# 5.4

## Power Pedestals

### RV Park Hook-Ups

#### Accessories

See Page V1-T5-75.

#### Dimensions

Approximate Dimensions in Inches (mm)

#### Newport Camp Mate

5

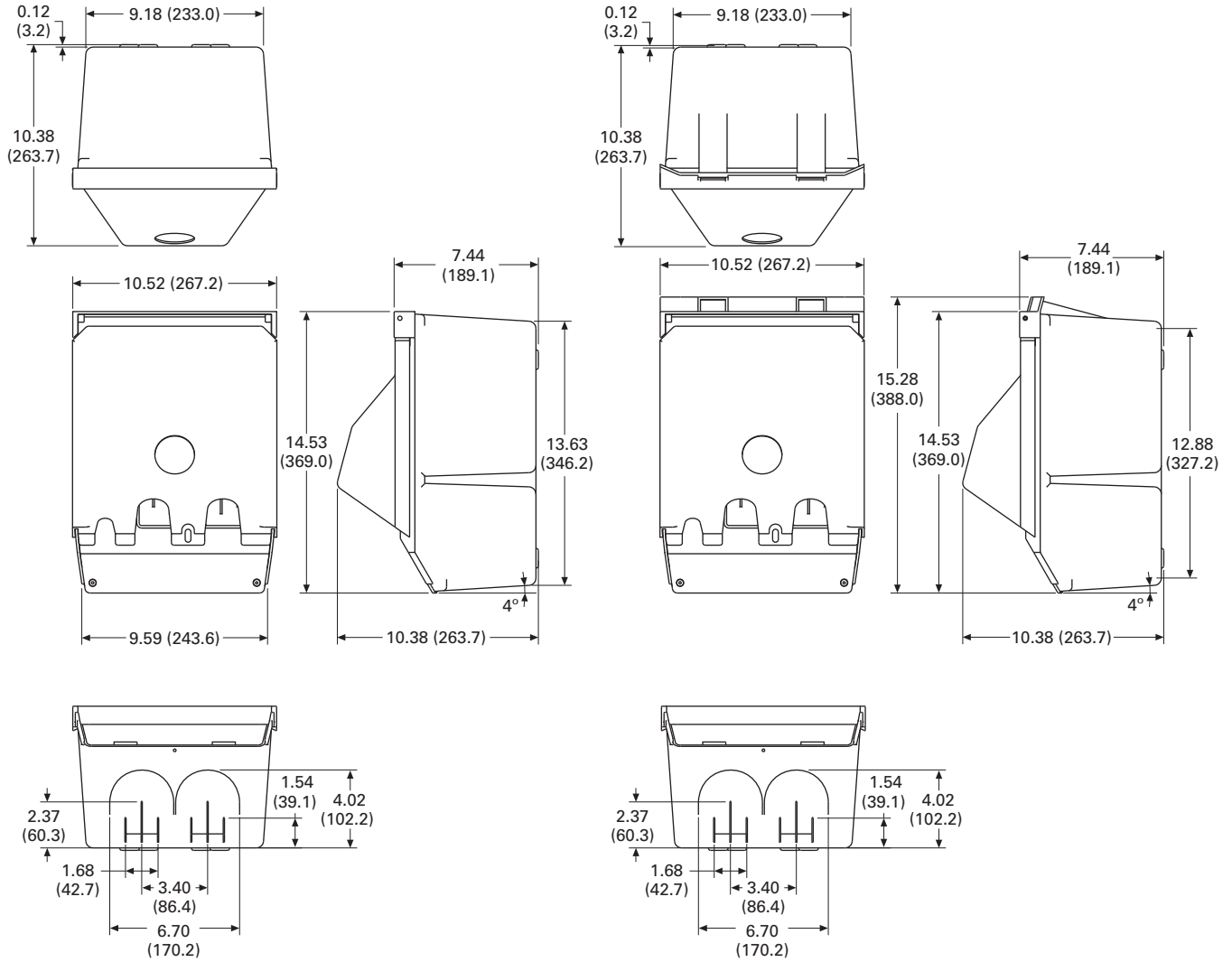

Newport Redesign

Newport Redesign With Meters



Park Light Power Pedestal



**Contents**

<i><b>Description</b></i>	<i><b>Page</b></i>
Power Pedestals . . . . .	<b>V1-T5-28</b>
Powerhouse Power Pedestal . . . . .	<b>V1-T5-30</b>
Powerhouse—Stainless Steel (SS) Power Pedestal . . . . .	<b>V1-T5-33</b>
Newport Camp Mate Power Pedestal . . . . .	<b>V1-T5-36</b>
Park Light Power Pedestal	
Catalog Number Selection . . . . .	<b>V1-T5-40</b>
Accessories . . . . .	<b>V1-T5-41</b>
Dimensions . . . . .	<b>V1-T5-41</b>
Firehouse . . . . .	<b>V1-T5-42</b>
Digital Electronic Kilowatt-hour Meters . . . . .	<b>V1-T5-44</b>
Distribution Equipment—Ground Fault Monitor . . . . .	<b>V1-T5-45</b>
Distribution Equipment—Substations . . . . .	<b>V1-T5-46</b>
Distribution Equipment—Panels . . . . .	<b>V1-T5-49</b>
Distribution Equipment—Transformers . . . . .	<b>V1-T5-50</b>

**Park Light Power Pedestal**

**Product Description**

The elegant design of the Park Light complements park landscaping and provides essential lighting required for park safety and security for campground paths, walkways, recreational areas and even pools. The Park Light has the same 360 degree lighting design as the Powerhouse and a resin housing that will never rust or deteriorate.

At 10¢/kWH, it will provide area lighting at a cost of less than 50¢/month and the bulbs will last for about three years. The Park Light is a perfect lighting fixture for any campground and especially for RV parks with Powerhouse utility centers.

**Features**

- Photocell controlled dual 13 watt fluorescent light with amber lens
- Engineered resin housing with a two-part polyurethane coating for a UV-resistant, long-lasting finish
- Limited lifetime warranty on the housing
- Loop-feed 1/4-inch stud lug copper busbars that can accept 2/0 AWG wire

**Available Options**

- Clear lens
- Photocell controlled single or dual 7 watt or 13 watt fluorescent light
- Phone (RJ-11)
- Cable TV
- High-speed Internet (RJ-45)
- Water faucet(s) with 3/4-inch hose bib
- Water—anti-siphon backflow preventer
- Digital electronic meter
- Wireless remote reading of electronic kilowatt meter
- Direct burial ground mounting stand
- Custom paint color

**Standards and Certifications**

The housing has a limited lifetime warranty, and the unit is UL listed.



#### Catalog Number Selection

**H D Y B D 4 7 0 1 2 A M**

Type	
<b>H</b>	= Hatteras Light
<b>R</b>	= Park Light

Lighting and Lens Color	
<b>A</b>	= 7 W light Amber
<b>B</b>	= Dual 7 W light Amber
<b>C</b>	= 9 W light Amber
<b>D</b>	= 13 W light Amber
<b>E</b>	= Dual 13 W light Amber
<b>F</b>	= No lighting Amber
<b>G</b>	= 7 W light Clear
<b>H</b>	= Dual 7 W light Clear
<b>I</b>	= 9 W light Clear
<b>J</b>	= 13 W light Clear
<b>K</b>	= Dual 13 W light Clear
<b>L</b>	= No lighting Clear
<b>M</b>	= 7 W light Special
<b>N</b>	= Dual 7 W light Special
<b>O</b>	= 9 W light Special
<b>P</b>	= 13 W light Special
<b>Q</b>	= Dual 13 W light Special
<b>R</b>	= No lighting Special
<b>S</b>	= 350 MA LED Amber
<b>T</b>	= 700 MA LED Amber
<b>U</b>	= 350 MA LED Clear
<b>V</b>	= 700 MA LED Clear
<b>W</b>	= 350 MA LED Special
<b>Y</b>	= 700 MA LED Special

Photocell	
<b>Y</b>	= Yes
<b>N</b>	= No

Lighting Protection	
<b>B</b>	= Breaker protected
<b>F</b>	= Fuse protected

Metering Type <sup>①</sup>	
<b>U</b>	= Unmetered
<b>D</b>	= Digital electronic meters
<b>R</b>	= Receptacles metered individually

Sides and Receptacles		
R1S1	R2S1	R1S2
<b>0</b>	<b>0</b>	<b>0</b>
<b>1</b>	<b>1</b>	<b>1</b>
<b>2</b>	<b>2</b>	<b>2</b>
<b>3</b>	<b>3</b>	<b>3</b>
<b>4</b>	<b>4</b>	<b>4</b>

**0** = None  
**1** = 20 A GFI duplex  
**2** = 30 A, 125 V  
**3** = 50 A, 125 V  
**4** = 50 A, 125/250 V

Water Option <sup>②</sup>	
<b>0</b>	= 0
<b>1</b>	= 1 (1/2-inch)
<b>2</b>	= 2 (1/2-inch)
<b>3</b>	= 1 (3/4-inch)
<b>4</b>	= 2 (3/4-inch)

Hard Wired Breakers	
<b>S1</b>	
<b>0</b>	= None
<b>2</b>	= 20 A, two-pole
<b>3</b>	= 30 A

Bus	
<b>S</b>	= Single-phase 1/4-inch copper busbar
<b>F</b>	= Three-phase 1/4-inch copper busbar
<b>C</b>	= Single-phase 1/4-inch Canadian busbar
<b>M</b>	= Mechanical lug 2/0
<b>A</b>	= 1/4-inch Canadian mechanical

Phone Cable TV and Internet Options		
Phone Jack	Cable TV Jack	Internet Option
<b>A</b>	= 1	0
<b>B</b>	= 1	0
<b>C</b>	= 1	0
<b>D</b>	= 1	1
<b>E</b>	= 1	1
<b>F</b>	= 1	2
<b>G</b>	= 1	2
<b>H</b>	= 1	2
<b>I</b>	= 1	2
<b>J</b>	= 2	0
<b>M</b>	= 2	1
<b>P</b>	= 2	0
<b>S</b>	= 0	2
<b>T</b>	= 0	1
<b>U</b>	= 0	2
<b>V</b>	= 0	1
<b>W</b>	= 0	1
<b>X</b>	= 0	2
<b>Y</b>	= 0	2
<b>Z</b>	= 0	2

Receptacle: R1 = Receptacle 1, Side 1  
 R2 = Receptacle 2, Side 2

**Notes**

- ① 20 A GFIs not metered.
- ② Number represents the quantity of 1/4-turn ball valves with 3/4-inch hose bibs (with stand only).

**Accessories**

See Page V1-T5-75.

**Dimensions**

Approximate Dimensions in Inches (mm)

**Park Light**

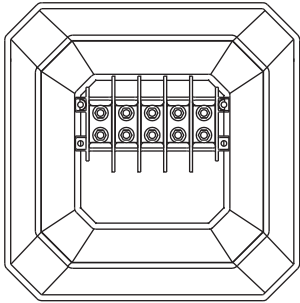

Busbar Access Top Removed

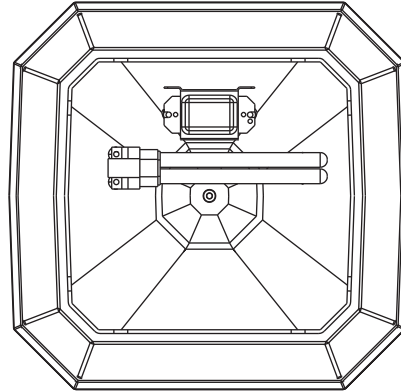

Inside Top

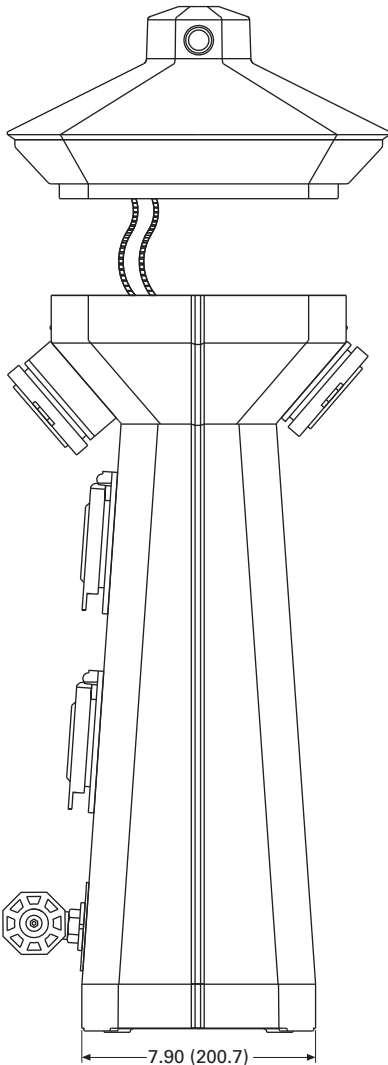

Side View

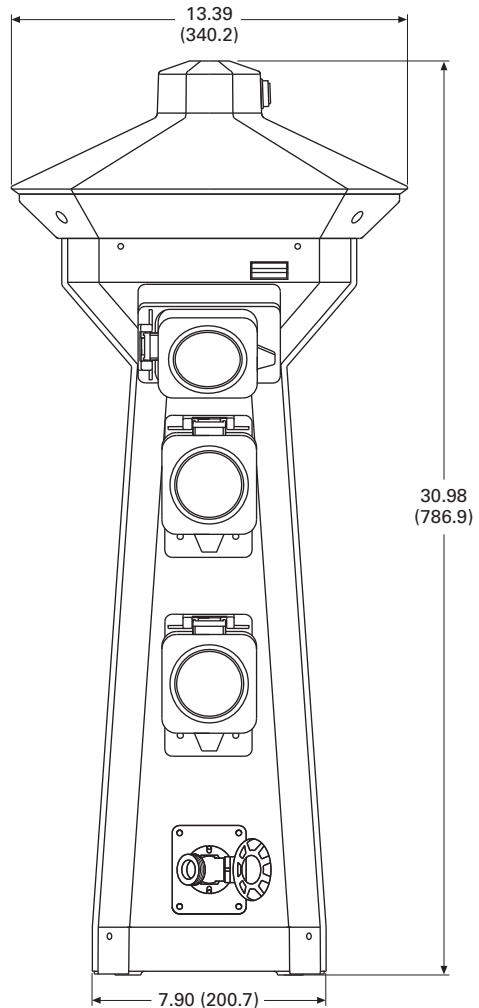

Front View

Firehouse



### Contents

<i>Description</i>	<i>Page</i>
Power Pedestals . . . . .	<b>V1-T5-28</b>
Powerhouse Power Pedestal . . . . .	<b>V1-T5-30</b>
Powerhouse—Stainless Steel (SS) Power Pedestal . . . . .	<b>V1-T5-33</b>
Newport Camp Mate Power Pedestal . . . . .	<b>V1-T5-36</b>
Park Light Power Pedestal . . . . .	<b>V1-T5-39</b>
Firehouse	
Accessories . . . . .	<b>V1-T5-43</b>
Dimensions . . . . .	<b>V1-T5-43</b>
Digital Electronic Kilowatthour Meters . . . . .	<b>V1-T5-44</b>
Distribution Equipment—Ground Fault Monitor . . . . .	<b>V1-T5-45</b>
Distribution Equipment—Substations . . . . .	<b>V1-T5-46</b>
Distribution Equipment—Panels . . . . .	<b>V1-T5-49</b>
Distribution Equipment—Transformers . . . . .	<b>V1-T5-50</b>

### Firehouse

#### Product Description

The Firehouse is designed to provide added fire safety to RV parks and campgrounds. The Firehouse provides a convenient location and easy access to fire extinguishers and to an optional life ring when installed around pools and waterfront amenities.

In addition, the Firehouse provides area lighting for easy identification during an emergency and for security lighting around the unit. The Firehouse can be equipped with an alarm strobe light and siren, which are automatically activated when the fire extinguisher cabinet door is opened or the optional life ring is removed.

#### Features

- Photocell controlled 13 watt fluorescent light
- Amber lens for bug reduction
- 10 lb ABC Type fire extinguisher
- Stainless steel housing with oven-baked enamel finish with an engineered resin base and top
- Limited lifetime warranty on the housing

#### Available Options

- Alarm strobe light and siren
- Optional 24-inch white or orange life ring for poolside or dockside installations
- 20 lb ABC Type fire extinguisher

#### Catalog Number Selection

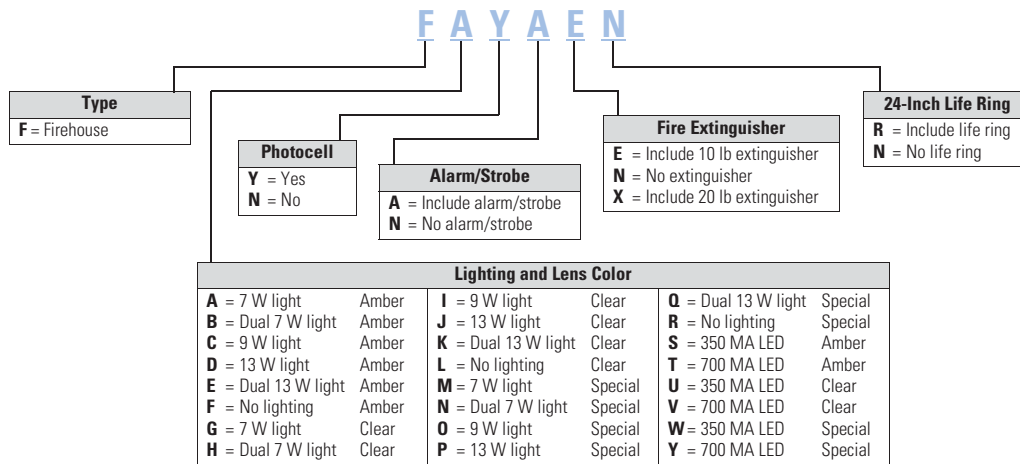

**Accessories**

See **Page V1-T5-75**.

**Dimensions**

Approximate Dimensions in Inches (mm)

**Firehouse-SS**

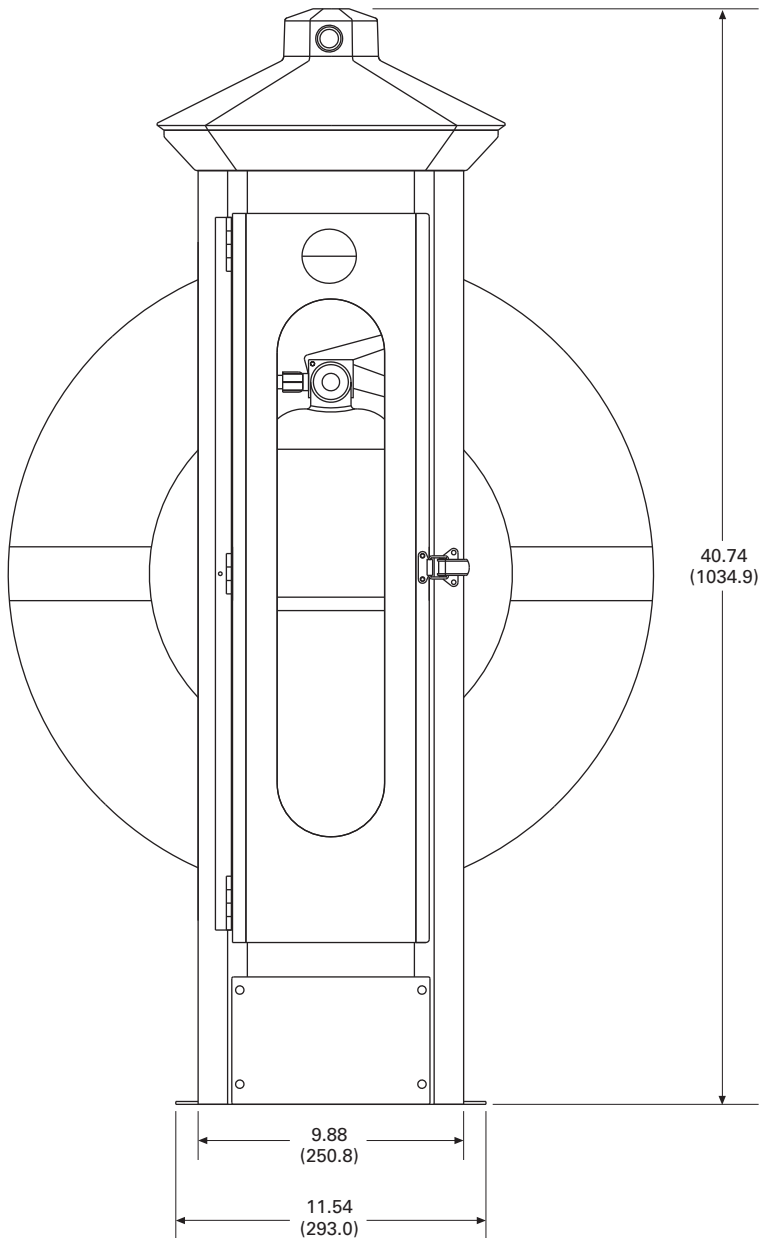

#### Digital Electronic Kilowatthour Meters



#### Digital Electronic Kilowatthour Meters

##### Product Description

Using the latest surface mount technology, Eaton manufactures a digital electronic kilowatt hour meter that exceeds the +/- 2% accuracy required by ANSI (American National Standards Institute) C-12.1 and is approved by the state of California at +/- 1% over the full range of 0–100 A from a 0.5 to 1 power factor and is available for both single- and three-phase applications.

The meter drives an electro-mechanical counter that requires a 12 V pulse each tenth of a kilowatthour, providing 10 pulses per kilowatt used. The meter output can be hard wired or connected to a transmitter in the pedestal for wireless transmission to a receiver displaying the output on a PC for direct billing of up to 1,000 individual customers.

##### Features

Our meter is designed to be user friendly in that all connections from external sources and the meter output are through one 14-pin locking connector. This feature eliminates many common problems, such as reverse line polarity and improper coil polarity. Simple LEDs, both red and green, indicate line and load condition and the pulsed LED indicates the rate of power consumption.

##### Wireless System

All of our meters are “wireless capable” to allow for wireless meter reading. This technology enables the marina or RV park to get meter readings from one central location rather than visiting every site to read the counters.

##### Meter Socket Capabilities

Meter sockets are available on the Powerhouse and Powerhouse–SS.

##### Standard:

- Four jaw
- Ring-type
- 100 A

#### Contents

##### Description

	<i>Page</i>
Power Pedestals . . . . .	<b>V1-T5-28</b>
Powerhouse Power Pedestal . . . . .	<b>V1-T5-30</b>
Powerhouse—Stainless Steel (SS) Power Pedestal . . . . .	<b>V1-T5-33</b>
Newport Camp Mate Power Pedestal . . . . .	<b>V1-T5-36</b>
Park Light Power Pedestal . . . . .	<b>V1-T5-39</b>
Firehouse . . . . .	<b>V1-T5-42</b>
Digital Electronic Kilowatthour Meters	
Distribution Equipment—Ground Fault Monitor . . . . .	<b>V1-T5-45</b>
Distribution Equipment—Substations. . . . .	<b>V1-T5-46</b>
Distribution Equipment—Panels. . . . .	<b>V1-T5-49</b>
Distribution Equipment—Transformers. . . . .	<b>V1-T5-50</b>

##### Available Options

- 200 A (SS only)
- Lockable hasp
- Ringless (SS only)
- Five jaw
- Seven jaw (SS only)

##### Product Selection



*One Element Meter*



*Two Element Meter*



*Three Element Meter*

## Ground Fault Monitor

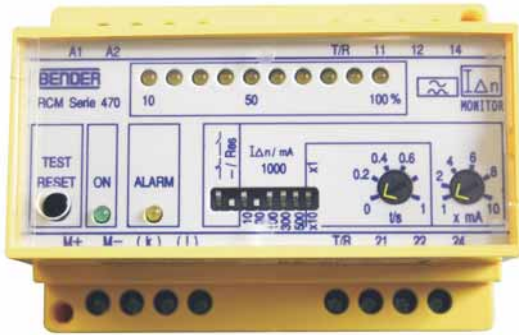

## Contents

**Description**

	<b>Page</b>
Power Pedestals . . . . .	<b>V1-T5-28</b>
Powerhouse Power Pedestal . . . . .	<b>V1-T5-30</b>
Powerhouse—Stainless Steel (SS) Power Pedestal . . . . .	<b>V1-T5-33</b>
Newport Camp Mate Power Pedestal . . . . .	<b>V1-T5-36</b>
Park Light Power Pedestal . . . . .	<b>V1-T5-39</b>
Firehouse . . . . .	<b>V1-T5-42</b>
Digital Electronic Kilowatthour Meters . . . . .	<b>V1-T5-44</b>
Distribution Equipment—Ground Fault Monitor . . . . .	
Distribution Equipment—Substations. . . . .	<b>V1-T5-46</b>
Distribution Equipment—Panels. . . . .	<b>V1-T5-49</b>
Distribution Equipment—Transformers. . . . .	<b>V1-T5-50</b>

**Distribution Equipment—Ground Fault Monitor****Product Description**

New to our product offering are ground fault monitoring systems designed to detect fault currents in the AC shore power system that are too low to trip a circuit breaker. The Ground Fault Monitor helps reduce the risk of injury or property damage, which may result from stray fault currents. Our ground fault monitoring system provides information to the maintenance staff on the overall condition of the AC electrical system. The ground fault monitoring system operates 24 hours a day and can be monitored by non-technical personnel.

**Features**

- UL listed current transformers
- Adjustable trip level 10 mA to 10 A
- Current transformers up to 8 1/4-inch diameter
- Visual and/or audible alarm
- Housing of fiberglass or powder coated stainless steel available

**Power Guard**

The ground fault monitor detects ground fault currents by means of current transformers (CT), which are placed around main or branch circuits. If a ground fault occurs, the CT will detect the amount of fault current and send a signal to the ground fault monitoring device where the amount of fault current is displayed with the faulty circuit identified. The detected fault can either activate an indicator alarm or disconnect the faulted circuit.

#### Substations



*Side-by-Side Substation*

#### Distribution Equipment—Substations

##### Product Description

The introduction of substations into the marina and recreational vehicle market allows Eaton to be your complete marina and RV park electrical products supplier. We are able to assist in the design and layout of your marina or RV park electrical system from the primary service provider to your power pedestal. Our substations are designed for any coastal or inland environment and are constructed of powder-coated stainless steel NEMA 3R housing cabinets. All substation cabinets come with our limited lifetime warranty. All of our substations use Eaton's panels and circuit breakers, providing our customers the utmost in circuit protection and quality.

##### Application Description

The aluminum and Galvaneal cabinets are recommended for inland applications. The substations can be configured with 50 to 330 kVA single-phase or three-phase copper wound transformers and up to 20 single-phase or 12 three-phase branch breakers. An optional three-sided double-wall cabinet is available that provides air flow between the panels. All substations come standard with temperature-controlled cooling fans.

#### Contents

<i>Description</i>	<i>Page</i>
Power Pedestals . . . . .	<b>V1-T5-28</b>
Powerhouse Power Pedestal . . . . .	<b>V1-T5-30</b>
Powerhouse—Stainless Steel (SS) Power Pedestal . . . . .	<b>V1-T5-33</b>
Newport Camp Mate Power Pedestal . . . . .	<b>V1-T5-36</b>
Park Light Power Pedestal . . . . .	<b>V1-T5-39</b>
Firehouse . . . . .	<b>V1-T5-42</b>
Digital Electronic Kilowatthour Meters . . . . .	<b>V1-T5-44</b>
Distribution Equipment—Ground Fault Monitor . . . . .	<b>V1-T5-45</b>
Distribution Equipment—Substations	
Features, Benefits and Functions . . . . .	<b>V1-T5-47</b>
Available Options . . . . .	<b>V1-T5-48</b>
Standards and Certifications . . . . .	<b>V1-T5-48</b>
Dimensions . . . . .	<b>V1-T5-48</b>
Distribution Equipment—Panels . . . . .	<b>V1-T5-49</b>
Distribution Equipment—Transformers . . . . .	<b>V1-T5-50</b>

#### Product Selection Guide

##### Panel and Transformer Combinations

Panel	Transformer
<b>Single-Phase</b>	
200 A	50 kVA
300 A	75 kVA
400 A	100 kVA
600 A	150 kVA
700 A	167.5 kVA
800 A	200 kVA
1000 A	250 kVA
1200 A	330 kVA
<b>Three-Phase</b>	
100 A	45 kVA
200 A	75 kVA
300 A	112.5 kVA
400 A	150 kVA
600 A	225 kVA
800 A	300 kVA



**Features, Benefits and Functions**

- Limited lifetime warranty on the housing
- All stainless steel hardware
- Temperature controlled cooling fans in the transformer and circuit breaker compartments
- Lockable door

**Ventilation**

The substation ventilation is designed to optimize air circulation over and around the transformers and through the panel compartment so that the substation operates at lower temperatures.

Substations come equipped with temperature-controlled cooling fans for exhausting hot air from the cabinet and solar shield.

In addition, substations are available with a double-walled cabinet and solar shield, which allow for cooling of both the exterior surface of the cabinet and the internal components.

**Substations**

Stainless steel housing with polyester powder coating



Limited lifetime warranty on the housing

Stainless steel hardware with locking doors

Temperature-controlled fans for cooling

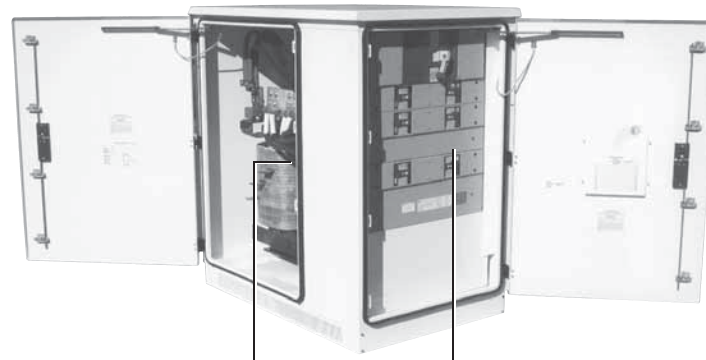
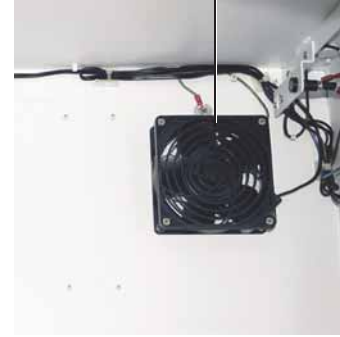

Custom made to your specifications:  
Single-phase or three-phase copper wound transformers  
50 to 330 kVA

Up to 1200 A main circuit breaker with  
20 single-phase or 12 three-phase  
branch circuit breakers

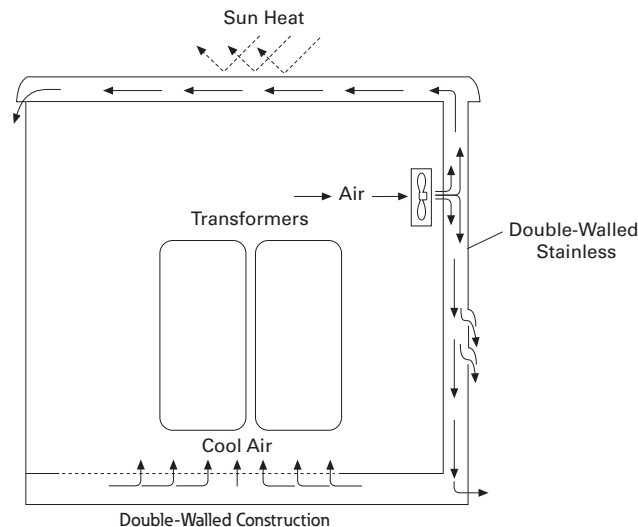

**Available Options**

- Powder-coated cabinets made of stainless steel or fiberglass
- Limited lifetime warranty on housing. Transformer and secondary distribution panel in a single enclosure have a one-year limited warranty
- Stainless steel housing and hardware with locking doors
- Single-phase and three-phase models
- Overload capacity meets ANSI L57.96–01.250
- Optional double-walled construction
- Temperature-controlled fans for cooling
- Custom-made copper wound single-phase or three-phase transformers from 50 to 330 kVA
- Up to 1200 A main circuit breaker with 15 single-phase branch circuit breakers or 10 three-phase branch circuit breakers
- Substations can be equipped with photocells to turn on and off lights
- A 20 A GFI can be installed in the cabinet, as well as a ground fault monitoring system

**Standards and Certifications**

- cULus listed

**Dimensions**

Approximate Dimensions in Inches (mm)

**Substations****Standard Substation**

Height	53.00 (1346.2)
Width	51.00 (1295.4)
Depth	33.00 (838.2)

**Side-by-Side Substation**

Height	53.00 (1346.2)
Width	66.00 (1676.4)
Depth	30.00 (762.0)

**Double Panel Substation**

Height	53.00 (1346.2)
Width	63.00 (1600.2)
Depth	33.00 (838.2)

Panels



Contents

<i>Description</i>	<i>Page</i>
Power Pedestals . . . . .	<b>V1-T5-28</b>
Powerhouse Power Pedestal . . . . .	<b>V1-T5-30</b>
Powerhouse—Stainless Steel (SS) Power Pedestal . . . . .	<b>V1-T5-33</b>
Newport Camp Mate Power Pedestal . . . . .	<b>V1-T5-36</b>
Park Light Power Pedestal . . . . .	<b>V1-T5-39</b>
Firehouse . . . . .	<b>V1-T5-42</b>
Digital Electronic Kilowatthour Meters . . . . .	<b>V1-T5-44</b>
Distribution Equipment—Ground Fault Monitor . . . . .	<b>V1-T5-45</b>
Distribution Equipment—Substations. . . . .	<b>V1-T5-46</b>
Distribution Equipment—Panels . . . . .	
Distribution Equipment—Transformers. . . . .	<b>V1-T5-50</b>

Distribution Equipment—Panels

Product Description

We now can offer our customers Eaton’s PRL-3A and PRL-4 panels as stand-alone units or in one of our substations. All of our busses are made of copper and are load rated, breakers are bolt-on type. Distribution panels can be single-phase or three-phase based on your system requirements. Distribution panels can also have a main breaker or a main lug. Branch circuit breakers are provided based on customer requirements.

Features

- All internal wiring is fine stranded 2000 V insulated copper
- Copper busbars
- All exterior hardware is stainless steel

Available Options

- NEMA 3R or 4X
- Powder-coated stainless steel
- Main breaker up to 1200 A
- Branch breaker 20 to 1200 A
- Main lug only
- We also offer 480 V models—single-phase and three-phase

Standards and Certifications

- UL listed
- cULus listed



Single-Phase

- Up to 1200 A main circuit breakers
- Up to 42 branch circuit breakers

Three-Phase

- Up to 1200 A main circuit breakers
- Up to 42 branch circuit breakers

#### Transformers



5

### Distribution Equipment—Transformers

#### Product Description

Because of the high humidity and corrosive conditions of coastal environments, our transformers are wound with Class H heavily insulated copper bar and are double dipped in tough insulating varnish that protects the copper, as well as reduces the hum that is typical in a transformer that is not double dipped. For marine applications, we provide a third overcoat of high temperature epoxy to protect against the severe saltwater environment. We can provide this transformer in single-phase, from 50 to 500 kVA, and three-phase, from 45 to 300 kVA.

#### Features

- Copper wound transformer coils double dipped in high temperature baking varnish
- Copper terminations
- Marine transformers with epoxy overcoat
- All copper-to-copper connections

### Contents

#### Description

<i>Description</i>	<i>Page</i>
Power Pedestals . . . . .	<b>V1-T5-28</b>
Product Selection Guide . . . . .	<b>V1-T5-29</b>
Powerhouse Power Pedestal . . . . .	<b>V1-T5-30</b>
Powerhouse—Stainless Steel (SS) Power Pedestal . . . . .	<b>V1-T5-33</b>
Newport Camp Mate Power Pedestal . . . . .	<b>V1-T5-36</b>
Park Light Power Pedestal . . . . .	<b>V1-T5-39</b>
Firehouse . . . . .	<b>V1-T5-42</b>
Digital Electronic Kilowatthour Meters . . . . .	<b>V1-T5-44</b>
Distribution Equipment—Ground Fault Monitor . . . . .	<b>V1-T5-45</b>
Distribution Equipment—Substations . . . . .	<b>V1-T5-46</b>
Distribution Equipment—Panels . . . . .	<b>V1-T5-49</b>
Distribution Equipment—Transformers . . . . .	

#### Available Options

- Single-phase: 50–500 kVA
- Three-phase: 45–300 kVA
- Epoxy overcoat for non-marine applications

#### Primary Voltages

- 480 wye three-phase
- 480 V three-phase delta three-wire + ground
- 480 V single-phase two-wire + ground

#### Secondary Voltages

- 127/220 V three-phase wye four-wire
- 120/208 V three-phase wye four-wire
- 120/240 V single-phase three-wire

#### Marina Power Distribution Transformer kVA Availabilities

- Single-phase: 50, 75, 100, 150, 167.5, 200, 250, 330, 500 kVA
- Three-phase: 45, 75, 112.5, 150, 225, 300 kVA

#### Standards and Certifications

- cULus listed



Marina Power and Lighting Equipment



High-Quality, Weatherproof Electrical Equipment

Contents

<i>Description</i>	<i>Page</i>
Power Pedestals	
Product Selection Guide . . . . .	V1-T5-52
Lighthouse . . . . .	V1-T5-54
Lighthouse-SS . . . . .	V1-T5-58
Admiral-SS . . . . .	V1-T5-62
Newport Harbor Mate. . . . .	V1-T5-65
Hatteras Light . . . . .	V1-T5-69
Firehouse . . . . .	V1-T5-73
Smart Start . . . . .	V1-T5-79
Mariner . . . . .	V1-T5-80
Digital Electronic Kilowatthour Meters . . . . .	V1-T5-81
Distribution Equipment—Ground Fault Monitor . .	V1-T5-82
Distribution Equipment—Mega Yacht Powerpoint . .	V1-T5-83
Distribution Equipment—Substations. . . . .	V1-T5-86
Distribution Equipment—Panels. . . . .	V1-T5-89
Distribution Equipment—Transformers. . . . .	V1-T5-90



Power Pedestals

Product Overview

Known as a leader in electrical control, power distribution, and industrial automation products and services, Eaton is a quality driven company that constantly looks for ways to provide enhanced product and service solutions for their customers. Eaton will be able to provide Marina developers a complete electrical solution. For more information on the other products available from Eaton, visit us online at [www.eaton.com](http://www.eaton.com) or [www.marinapower.com](http://www.marinapower.com).

What Eaton has to Offer

- Eaton has more marina power outlets in service than all other suppliers combined
- We offer complementary comprehensive in-house electrical designs for your complete marina development using all high quality Eaton products
- We can provide your marina development with complete remote wireless digital electronic meter reading
- Not only can Eaton provide your marina with the highest quality power pedestals and marine distribution equipment, we can also supply your entire electrical needs for your surrounding development and beyond from safety switches to loadcenters and much more

## Product Selection Guide

## Power Pedestal Quick Guide

	Lighthouse	Lighthouse-SS	Hatteras Light	Newport Harbor Mate	Admiral-SS	Firehouse	Mariner	Lookout	Power Point
Main housing	Engineered resin	Stainless steel	Engineered resin	Engineered resin	Stainless steel	Stainless steel	Engineered resin	Stainless steel	Stainless steel
Top	Engineered resin	Engineered resin	Engineered resin	Engineered resin	Stainless steel	Engineered resin	Engineered resin	Stainless steel	Stainless steel
Optional stand	—	—	—	Stainless steel	—	—	PVC	—	—
External hardware	Stainless steel	Stainless steel	Stainless steel	Stainless steel	Stainless steel	Stainless steel	Stainless steel	Stainless steel	Stainless steel
Standard lightwattage(s)	13 W	13 W	13 W	7 W	13 W	13 W	5 W, 7 W & 13 W	—	13 W
LED lighting option	Yes	Yes	Yes	No	Yes	Yes	No	No	Yes
Photocell	Yes	Yes	Yes	Yes	Yes	Yes	No	No	Yes
Lockable doors	Yes	Yes	Yes	Yes	Yes	—	—	—	Yes
Hose hangers	Yes	Yes	No	No	Yes	No	No	No	No
Electric meters	Yes—up to 4	Yes—up to 4	Yes—up to 2	Yes—up to 2	Yes—up to 4	No	No	No	Yes—up to 6
Remote meter reading	Yes	Yes	Yes	Yes	Yes	No	No	No	Yes
Water	Two 3/4"	Two 3/4"	Two 1/2"	Two 3/4"	Two 3/4"	None	None	None	One 3/4" or more
Water meters	Yes	Yes	No	Yes	Yes	No	No	No	Yes
Telephone	Yes	Yes	Yes	Yes	Yes	No	No	No	Yes
Cable TV	Yes	Yes	Yes	Yes	Yes	No	No	No	Yes
Internet	Yes	Yes	Yes	Yes	Yes	No	No	No	Yes
Fire extinguisher	No	No	No	No	No	Yes—up to 20 lbs	No	No	No
Life ring	No	No	No	No	No	Yes—24"	No	No	No
Alarm and strobe light	No	No	No	No	No	Yes	No	No	No
20 A 110 V GFI	Yes	Yes	Yes	Yes	Yes	No	No	No	Yes
30 A 125 V twist—lock	Yes	Yes	Yes	Yes	Yes	No	No	No	Yes
50 A 125/250 V twist—lock	Yes	Yes	Yes	Yes	Yes	No	No	No	Yes
100 A 120/240 V pin and sleeve	Yes	Yes	No	No	Yes	No	No	No	Yes
100 A 120/208 V pin and sleeve	Yes	Yes	No	No	Yes	No	No	No	Yes
100 A 277/480 V pin and sleeve	Yes	Yes	No	No	Yes	No	No	No	Yes
100 A 480 V pin and sleeve	Yes	Yes	No	No	Yes	No	No	No	Yes
200 A 480 V pin and sleeve	No	No	No	No	Yes	No	No	No	Yes
Hardwire compatible	No	No	No	No	No	No	No	No	Yes
TVSS compatible	Yes	Yes	No	No	Yes	No	No	No	Yes
Card swipe compatible	Yes	Yes	No	Yes	Yes	No	No	No	Yes
Security camera compatible	No	No	No	No	No	No	No	Yes	No
Busbar rating	Up to 500 A	Up to 500 A	Up to 140 A	Up to 140 A	Up to 500 A	—	—	—	Up to 800 A
Maximum wire size—single feed	350 kcmil	350 kcmil	#2/0	#2/0	350 kcmil	—	—	—	(3) 500 kcmil
Maximum wire size—loop feed	#4/0	#4/0	#1	#1	350 kcmil	—	—	—	(3) 500 kcmil
Height	44"	40"	30"	36"	48"	43.5"	24" to 72"	72" to 96"	50"
Width	13.75"	9.875"	7.5"	10.5"	14"	9.875"	7"	9"	50"
Depth	13.75"	9.875"	7.5"	14.5"	14"	9.875"	7"	9"	36"
<b>Warranty</b>									
Housing	Limited lifetime	Limited lifetime	Limited lifetime	Limited lifetime	Limited lifetime	Limited lifetime	Limited lifetime	Limited lifetime	Limited lifetime
Receptacles and breakers	2 years	2 years	2 years	2 years	2 years	—	—	—	2 years
Lighting assembly	1 year	1 year	1 year	1 year	1 year	1 year	1 year	—	1 year

Receptacles

Side One		Side Two	
None	None	None	None
30 A	None	None	None
30 A	30 A	None	None
30 A	None	30 A	None
30 A	30 A	30 A	30 A
30 A	50 A	None	None
30 A	None	50 A	None
30 A	50 A	30 A	50 A
50 A	None	None	None
50 A	50 A	None	None
50 A	None	50 A	None
50 A	50 A	50 A	50 A
100 A 120/240 V	None	None	None
100 A 120/240 V	None	50–50 A	None
100 A 120/240 V	None	100 A 120/240 V	None
100 A 120/240 V	50–50 A	100 A 120/240 V	50–50 A
100 A 120/208 V	None	None	None
100 A 120/208 V	None	100 A 120/240 V	None
100 A 120/240 V	100 A 120/240 V	100 A 120/240 V	100 A 120/240 V
100 A 120/208 V	100 A 120/208 V	100 A 120/208 V	100 A 120/208 V
100 A 120/240 V	100 A 120/240 V	100 A 120/208 V	100 A 120/208 V

Receptacle Configuration Availability

Lighthouse	Lighthouse-SS	Admiral-SS	Hatteras Light	Newport Harbor Mate
<b>Receptacle Available with GFI Receptacles</b>				
Yes	Yes	Yes	Yes	Yes
Yes	Yes	Yes	Yes	Yes
Yes	Yes	Yes	No	Yes
Yes	Yes	Yes	Yes	No
Yes	Yes	Yes	No	No
Yes	Yes	Yes	No	Yes
Yes	Yes	Yes	Yes ①	No
Yes	Yes	Yes	No	No
Yes	Yes	Yes	Yes	Yes
Yes	Yes	Yes	No	Yes
Yes	Yes	Yes	No	No
Yes	Yes	Yes	No	No
Yes	Yes	Yes	No	No
Yes	Yes	Yes	No	No
Yes	Yes	Yes	No	No
No	No	Yes	No	No
Yes	Yes	Yes	No	No
Yes	Yes	Yes	No	No
No	No	Yes	No	No
No	No	Yes	No	No
No	No	Yes	No	No

**Note**

① Configuration available with no additional GFI receptacles.

Lighthouse



5

## Contents

<i>Description</i>	<i>Page</i>
Power Pedestals . . . . .	<b>V1-T5-51</b>
Lighthouse	
Available Options . . . . .	<b>V1-T5-55</b>
Catalog Number Selection . . . . .	<b>V1-T5-56</b>
Accessories . . . . .	<b>V1-T5-57</b>
Dimensions . . . . .	<b>V1-T5-57</b>
Lighthouse-SS . . . . .	<b>V1-T5-58</b>
Admiral-SS . . . . .	<b>V1-T5-62</b>
Newport Harbor Mate . . . . .	<b>V1-T5-65</b>
Hatteras Light . . . . .	<b>V1-T5-69</b>
Firehouse . . . . .	<b>V1-T5-73</b>
Smart Start . . . . .	<b>V1-T5-79</b>
Mariner . . . . .	<b>V1-T5-80</b>
Digital Electronic Kilowatthour Meters . . . . .	<b>V1-T5-81</b>
Distribution Equipment—Ground Fault Monitor . . . . .	<b>V1-T5-82</b>
Distribution Equipment—Mega Yacht Powerpoint . . . . .	<b>V1-T5-83</b>
Distribution Equipment—Substations . . . . .	<b>V1-T5-86</b>
Distribution Equipment—Panels . . . . .	<b>V1-T5-89</b>
Distribution Equipment—Transformers . . . . .	<b>V1-T5-90</b>

## Lighthouse

### Product Description

One of our most popular units, the all-purpose Lighthouse® pedestal has a wide range of features. With units in service around the world, this stylish power pedestal is recognized for its practicality and exceptional durability.

Engineered to withstand the most severe weather conditions, Lighthouse power pedestals can be found in marinas from Alaska to the tropics.

**Note:** Custom paint color.

**Note:** Wireless remote reading of electronic kilowatt meters.

**Note:** Clear lens.

### Features, Benefits and Functions

- Photocell controlled 13 watt fluorescent light (clear lens or amber lens for bug reduction)
- Lockable weatherproof doors that protect breakers and receptacles while in use (a requirement of NFPA 303 and NEC Article 555)
- Hose and cable brackets
- Heavy resin housing with a two-part polyurethane coating for a UV-resistant, long-lasting finish
- Copper busbar with ratings from 250 to 500 A
- New “hingeless” base providing easy access for both installation and maintenance
- Backlit faceplate for easy receptacle plug-in at night



**Lighthouse**

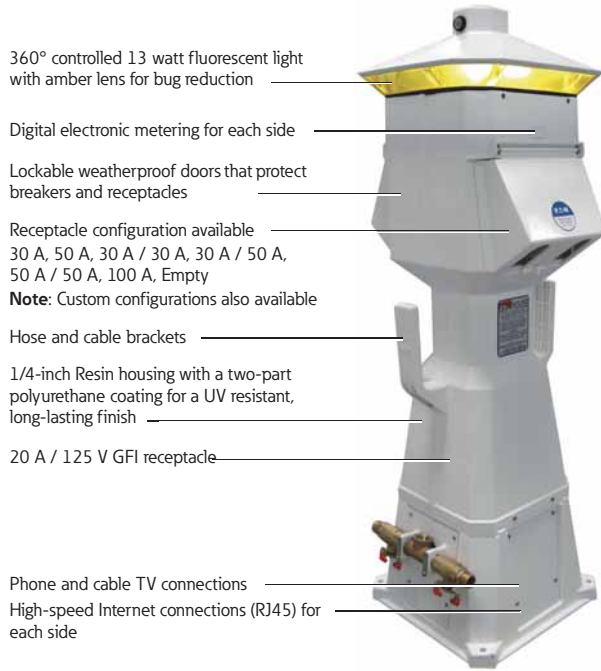

360° controlled 13 watt fluorescent light with amber lens for bug reduction

Digital electronic metering for each side

Lockable weatherproof doors that protect breakers and receptacles

Receptacle configuration available  
30 A, 50 A, 30 A / 30 A, 30 A / 50 A,  
50 A / 50 A, 100 A, Empty

**Note:** Custom configurations also available

Hose and cable brackets

1/4-inch Resin housing with a two-part polyurethane coating for a UV resistant, long-lasting finish

20 A / 125 V GFI receptacle

Phone and cable TV connections

High-speed Internet connections (RJ45) for each side

**Available Options**

- Digital electronic metering (one, two or three element meters available)
- Built-in meter socket
- 20 A / 125 V GFI receptacle (max. of two GFI receptacles per pedestal)

**Note:** 20 A GFI receptacles are not to be used for shore power.

- High-speed Internet connections
- Wireless remote metering for electric and water
- Transient voltage surge suppressor (TVSS) to protect from voltage surges, spikes or lightning on the AC power line (extends warranty on internal parts to three years)
- Stainless steel door hinge on receptacle main doors
- Single or dual steel 1/4-turn ball valves with 3/4-inches
- Hose bibs and stainless steel handles
- Single or dual phone and/or cable TV connections
- Base cap
- Base extension
- LED lighting

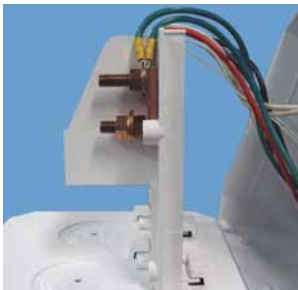

**Copper Busbar with Ratings from 250 to 500 A**



**Cable and Internet Connections**



**New Hingeless Base**



**Optional Meter Socket**

#### Catalog Number Selection

**L D U 4 7 0 0 0 0 0 1 2 K M**

Type	
L	Lighthouse
S	LHSS

Lighting and Lens Color	
A	7 W light Amber
B	Dual 7 W light Amber
C	9 W light Amber
D	13 W light Amber
E	Dual 13 W light Amber
F	No lighting Amber
G	7 W light Clear
H	Dual 7 W light Clear
I	9 W light Clear
J	13 W light Clear
K	Dual 13 W light Clear
L	No lighting Clear
M	7 W light Special
N	Dual 7 W light Special
O	9 W light Special
P	13 W light Special
Q	Dual 13 W light Special
R	No lighting Special
S	350 MA LED Amber
T	700 MA LED Amber
U	350 MA LED Clear
V	700 MA LED Clear
W	350 MA LED Special
Y	700 MA LED Special

Metering Type	
U	Unmetered
D	Digital electronic meters (side one)
T	Digital electronic meters (side two)
B	Digital electronic meters (both sides)
R	Receptacles metered individually
M	One meter socket (100 A)
N	Two meter socket (100 A each)
V	200 A meter socket

Sides and Receptacles							
R1S1	R2S1	R3S1	R4S1	R1S2	R2S2	R3S2	R4S2
0	0	0	0	0	0	0	0
1	1	1	1	1	1	1	1
2	2	2	2	2	2	2	2
3	3	3	3	3	3	3	3
4	4	4	4	4	4	4	4
5	5	5	5	5	5	5	5
6	6	6	6	6	6	6	6
7	7	7	7	7	7	7	7
8	8	8	8	8	8	8	8

0 = None  
 1 = 20 A GFI duplex  
 2 = 30 A, 125 V  
 3 = 50 A, 125 V  
 4 = 50 A, 125/250 V  
 5 = 100 A, 208 V  
 6 = 100 A, 250 V  
 7 = 100 A, 277/480 V  
 8 = 100 A, 480 V

Water Option ①	
0	0
1	1
2	2
3	Single water meter
4	Dual water meter
5	Single meter, 2 V
6	1 frost free
7	2 frost free

Extra Unmetered GFI Receptacles ②	
0	None
1	1
2	2

Phone Cable TV and Internet Options		
Phone Jack	Cable TV Jack	Internet Option
A	1	0
B	1	0
C	1	0
D	1	1
E	1	1
F	1	2
G	1	2
H	1	2
I	1	2
J	2	0
K	2	0
L	2	0
M	2	1
N	2	1
O	2	1
P	2	2
Q	2	2
R	2	2
S	0	2
T	0	1
U	0	2
V	0	1
W	0	1
X	0	2
Y	0	0
Z	0	1
0	0	0

Bus	
S	Single-phase 3/8-inch copper busbar
F	Three-phase 3/8-inch copper busbar
C	Single-phase 3/8-inch Canadian busbar
T	Three-phase 3/8-inch Canadian busbar
M	Single-phase 300 kcmil mechanical lug bus
Z	Three-phase 300 kcmil mechanical lug bus
L	Single-phase 350 kcmil mechanical lug bus
P	Three-phase 350 kcmil mechanical lug bus
N	Single-phase 1/4-inch copper busbar
Q	Single-phase 1/4-inch split mechanical busbar

Receptacle: R1S1 = Receptacle 1, Side 1  
 R2S1 = Receptacle 2, Side 1  
 R1S2 = Receptacle 1, Side 2  
 R2S2 = Receptacle 2, Side 2

#### Notes

- ① Number represents the quantity of 1/4-turn ball valves with 3/4-inch hose bibs.
- ② Quantity of 20 A GFI duplex receptacles.

**Accessories**

See Page V1-T5-75.

**Dimensions**

Approximate Dimensions in Inches (mm)

**Lighthouse**

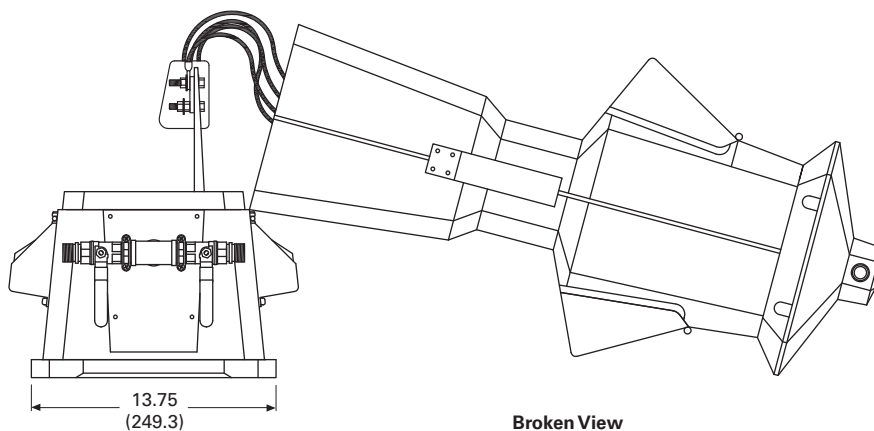
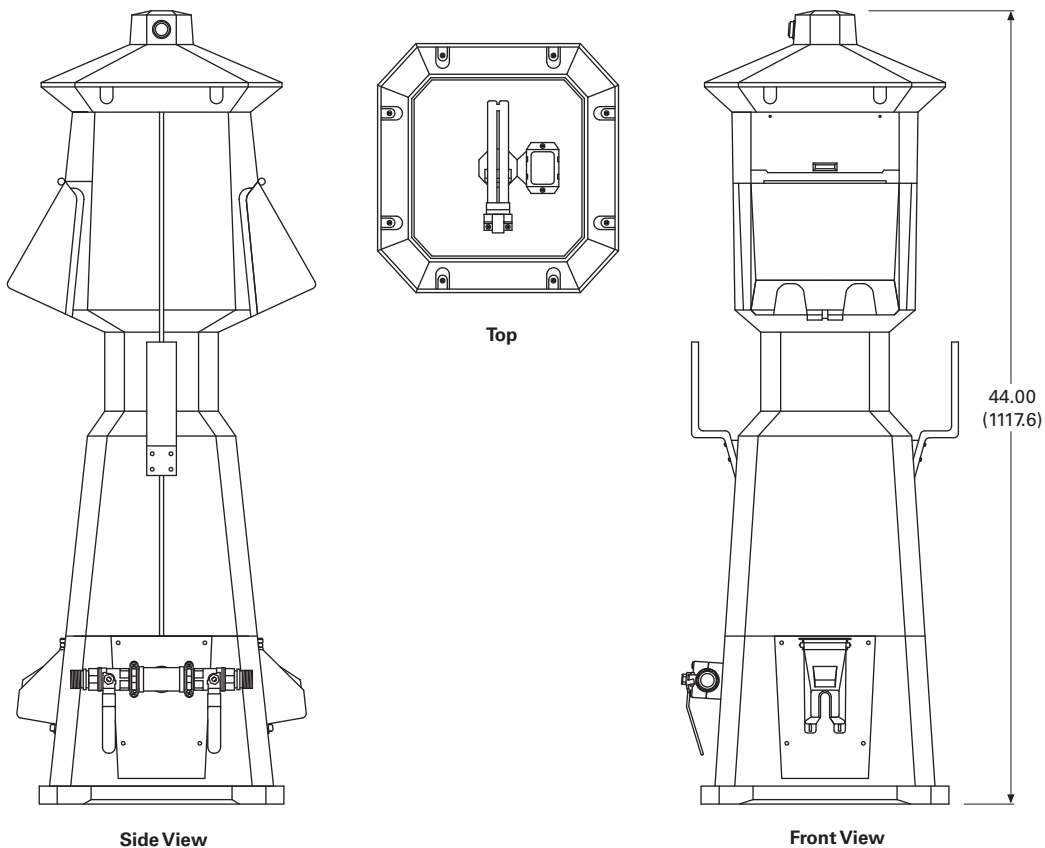

Lighthouse-SS



5

### Lighthouse-SS

#### Product Description

The Lighthouse-SS offers the same standard features and available options as the standard Lighthouse. But, like all of the stainless steel products manufactured here, the Lighthouse-SS is made with high-quality 316L stainless steel for superior quality and performance.

**Note:** 20/125 A GFI receptacle.

**Note:** Wireless remote reading of electronic kilowatt meters.

**Note:** Clear lens.

**Note:** Meter socket for each side powered (to accept glass style meter).

**Note:** Receptacle configurations available:

- 30 A
- 30 A / 30 A
- 30 A / 50 A
- 50 A / 50 A
- 100 A (single-phase) 120/240 V
- 100 A (three-phase) 120/208 V
- 200 A (three-phase) 480 V

#### Features, Benefits and Functions

- Photocell controlled 13 watt fluorescent light (clear lens or amber lens for bug reduction)
- Available with lockable weatherproof doors
- Hose and cable brackets
- Long-lasting maintenance-free 316L stainless steel housing with limited lifetime warranty
- Copper busbar with ratings from 250 to 500 A
- Large removable access panel for easy maintenance and installation
- Backlit faceplate for easy receptacle plug-in at night

### Contents

<i>Description</i>	<i>Page</i>
Power Pedestals . . . . .	V1-T5-51
Lighthouse . . . . .	V1-T5-54
Lighthouse-SS	
Available Options . . . . .	V1-T5-59
Catalog Number Selection . . . . .	V1-T5-60
Accessories . . . . .	V1-T5-61
Dimensions . . . . .	V1-T5-61
Admiral-SS . . . . .	V1-T5-62
Newport Harbor Mate . . . . .	V1-T5-65
Hatteras Light . . . . .	V1-T5-69
Firehouse . . . . .	V1-T5-73
Smart Start . . . . .	V1-T5-79
Mariner . . . . .	V1-T5-80
Digital Electronic Kilowatthour Meters . . . . .	V1-T5-81
Distribution Equipment—Ground Fault Monitor . . . . .	V1-T5-82
Distribution Equipment—Mega Yacht Powerpoint . . . . .	V1-T5-83
Distribution Equipment—Substations . . . . .	V1-T5-86
Distribution Equipment—Panels . . . . .	V1-T5-89
Distribution Equipment—Transformers . . . . .	V1-T5-90

**Lighthouse-SS**

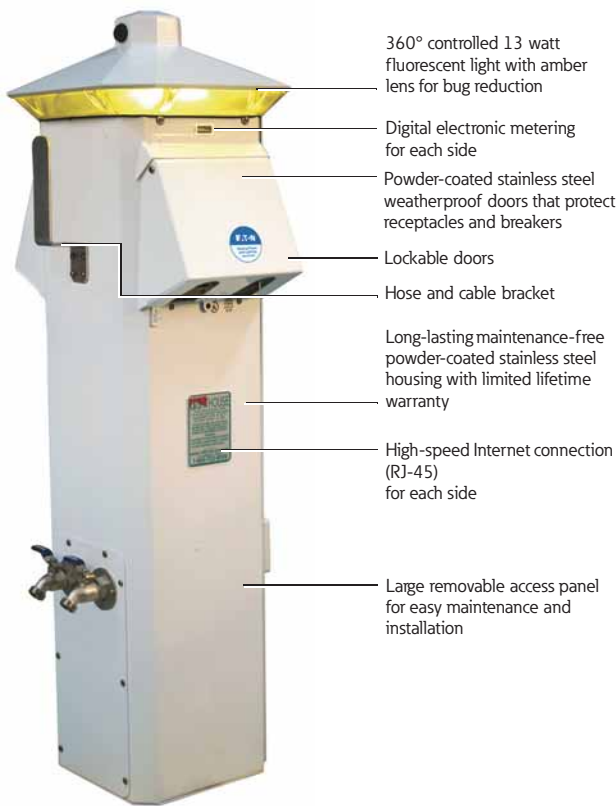

- 360° controlled 13 watt fluorescent light with amber lens for bug reduction
- Digital electronic metering for each side
- Powder-coated stainless steel weatherproof doors that protect receptacles and breakers
- Lockable doors
- Hose and cable bracket
- Long-lasting maintenance-free powder-coated stainless steel housing with limited lifetime warranty
- High-speed Internet connection (RJ-45) for each side
- Large removable access panel for easy maintenance and installation

**Available Options**

- Digital electronic metering (one, two or three element meters available)
- 20 A / 125 V GFI receptacle (max. of two GFI receptacles per pedestal)

**Note:** 20 A GFI receptacles are not to be used for shore power.

- High-speed Internet connection
- Wireless remote metering available for water and electricity
- Transient voltage surge suppressor (TVSS) to protect from voltage surges, spikes or lightning on the AC power line (extends warranty on internal parts to three years)
- Single or dual phone and/or cable TV connections
- Single or dual 3/4-inch hose bibs with stainless steel
- Handles LED lighting



**Phone and Cable TV Connections**



**New Door**



**Copper Busbar with Ratings from 250 to 500 A**

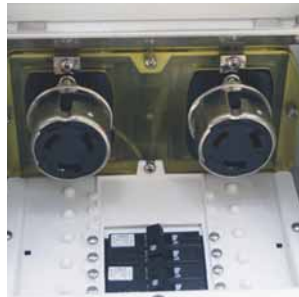

**Backlit Faceplate to Aid in Hooking Up at Night**

#### Catalog Number Selection

L D U 4 7 0 0 0 0 0 1 2 K M

Type	
L	Lighthouse
S	LHSS

Lighting and Lens Color	
A	7 W light Amber
B	Dual 7 W light Amber
C	9 W light Amber
D	13 W light Amber
E	Dual 13 W light Amber
F	No lighting Amber
G	7 W light Clear
H	Dual 7 W light Clear
I	9 W light Clear
J	13 W light Clear
K	Dual 13 W light Clear
L	No lighting Clear
M	7 W light Special
N	Dual 7 W light Special
O	9 W light Special
P	13 W light Special
Q	Dual 13 W light Special
R	No lighting Special
S	350 MA LED Amber
T	700 MA LED Amber
U	350 MA LED Clear
V	700 MA LED Clear
W	350 MA LED Special
Y	700 MA LED Special

Sides and Receptacles							
R1S1	R2S1	R3S1	R4S1	R1S2	R2S2	R3S2	R4S2
0	0	0	0	0	0	0	0
1	1	1	1	1	1	1	1
2	2	2	2	2	2	2	2
3	3	3	3	3	3	3	3
4	4	4	4	4	4	4	4
5	5	5	5	5	5	5	5
6	6	6	6	6	6	6	6
7	7	7	7	7	7	7	7
8	8	8	8	8	8	8	8

0 = None  
 1 = 20 A GFI duplex  
 2 = 30 A, 125 V  
 3 = 50 A, 125 V  
 4 = 50 A, 125/250 V  
 5 = 100 A, 208 V  
 6 = 100 A, 250 V  
 7 = 100 A, 277/480 V  
 8 = 100 A, 480 V

Water Option ①	
0	= 0
1	= 1
2	= 2
3	= Single water meter
4	= Dual water meter
5	= Single meter, 2 V
6	= 1 frost free
7	= 2 frost free

Extra Unmetered GFI Receptacles ②	
0	= None
1	= 1
2	= 2

Phone Cable TV and Internet Options		
Phone Jack	Cable TV Jack	Internet Option
A	= 1	0
B	= 1	0
C	= 1	0
D	= 1	1
E	= 1	1
F	= 1	1
G	= 1	2
H	= 1	2
I	= 1	2
J	= 2	0
K	= 2	0
L	= 2	0
M	= 2	1
N	= 2	1
O	= 2	1
P	= 2	2
Q	= 2	2
R	= 2	2
S	= 0	2
T	= 0	0
U	= 0	0
V	= 0	1
W	= 0	1
X	= 0	1
Y	= 0	2
Z	= 0	2
0	= 0	0

Metering Type	
U	= Unmetered
D	= Digital electronic meters (side one)
T	= Digital electronic meters (side two)
B	= Digital electronic meters (both sides)
R	= Receptacles metered individually
M	= One meter socket (100 A)
N	= Two meter socket (100 A each)
V	= 200 A meter socket

Bus	
S	= Single-phase 3/8-inch copper busbar
F	= Three-phase 3/8-inch copper busbar
C	= Single-phase 3/8-inch Canadian busbar
T	= Three-phase 3/8-inch Canadian busbar
M	= Single-phase 300 kcmil mechanical lug bus
Z	= Three-phase 300 kcmil mechanical lug bus
L	= Single-phase 350 kcmil mechanical lug bus
P	= Three-phase 350 kcmil mechanical lug bus
N	= Single-phase 1/4-inch copper busbar
Q	= Single-phase 1/4-inch split mechanical busbar

Receptacle: R1S1 = Receptacle 1, Side 1  
 R2S1 = Receptacle 2, Side 1  
 R1S2 = Receptacle 1, Side 2  
 R2S2 = Receptacle 2, Side 2

#### Notes

- ① Number represents the quantity of 1/4-turn ball valves with 3/4-inch hose bibs.
- ② Quantity of 20 A GFI duplex receptacles.

**Accessories**

See **Page V1-T5-75**.

**Dimensions**

Approximate Dimensions in Inches (mm)

**Lighthouse-SS**

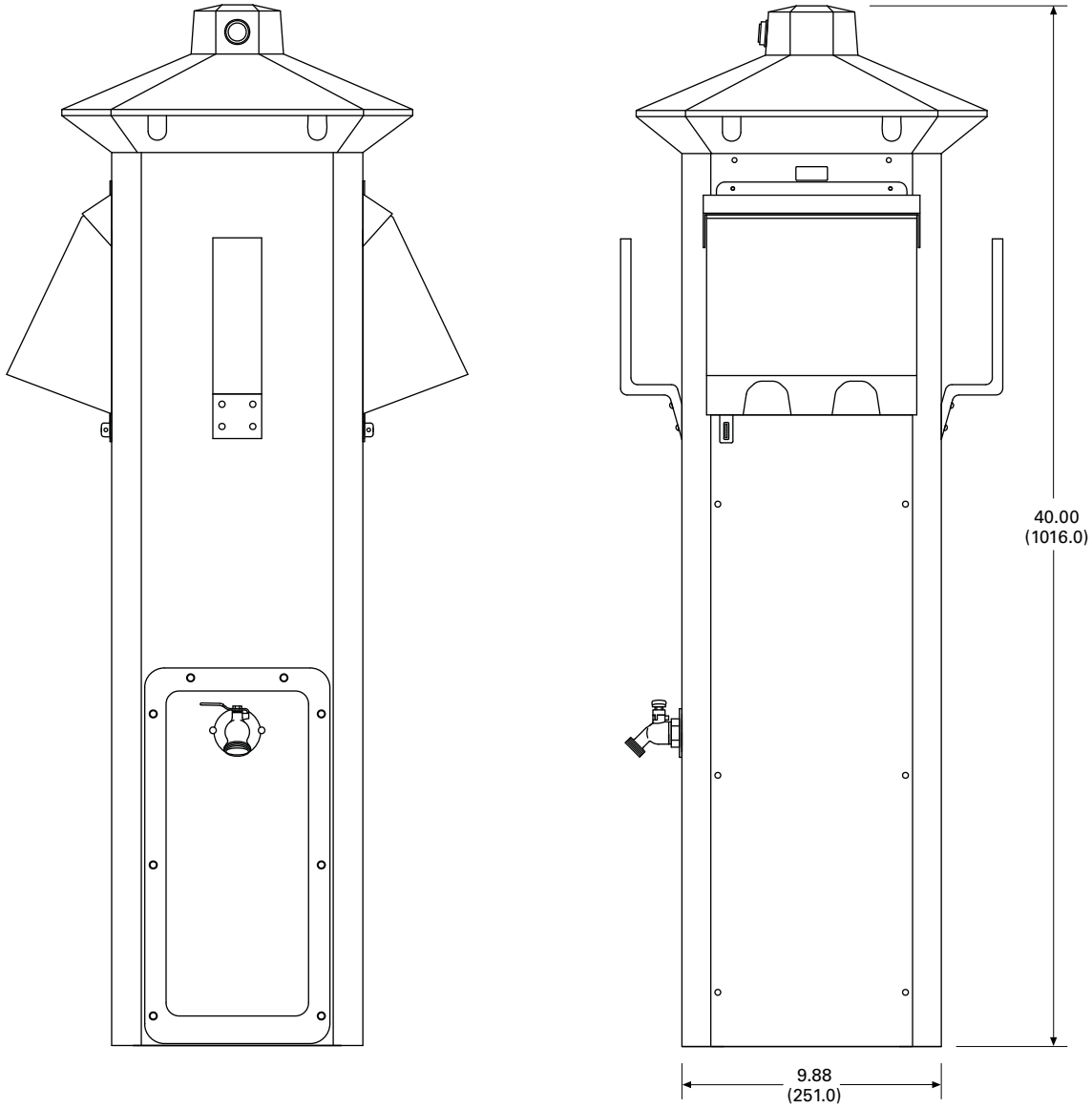

Admiral-SS



5

### Admiral-SS

#### Product Description

Truly the flagship of our unitized pedestal line, the Admiral-SS possesses amperage capabilities up to 500 A and voltages of 480/277 three-phase, 120/240 single-phase and combinations of these receptacles all in one unit to serve nearly any size Mega Yacht.

#### Features

- Heavy 316L stainless steel housing that is powder coated with a polyester resin
- Photocell controlled 13 watt fluorescent light with clear lens that provides 360 degrees of lighting

### Contents

#### Description

	<i>Page</i>
Power Pedestals . . . . .	V1-T5-51
Lighthouse . . . . .	V1-T5-54
Lighthouse-SS . . . . .	V1-T5-58
Admiral-SS	
Catalog Number Selection . . . . .	V1-T5-63
Accessories . . . . .	V1-T5-64
Dimensions . . . . .	V1-T5-64
Newport Harbor Mate . . . . .	V1-T5-65
Hatteras Light . . . . .	V1-T5-69
Firehouse . . . . .	V1-T5-73
Smart Start . . . . .	V1-T5-79
Mariner . . . . .	V1-T5-80
Digital Electronic Kilowatthour Meters . . . . .	V1-T5-81
Distribution Equipment—Ground Fault Monitor . . . . .	V1-T5-82
Distribution Equipment—Mega Yacht Powerpoint . . . . .	V1-T5-83
Distribution Equipment—Substations . . . . .	V1-T5-86
Distribution Equipment—Panels . . . . .	V1-T5-89
Distribution Equipment—Transformers . . . . .	V1-T5-90

#### Available Options

- Dual phone and/or cable TV connections
- Four 100 A receptacles of any two voltage combinations such as 277/480 three-phase, 120/208 three-phase or 120/240 single-phase
- 200 A / 480 V receptacles
- when the 100 A 120/240 V receptacles are used, two 50 A 120/240 V receptacles can also be provided for a total of 500 A
- 20 A / 125 V GFI receptacle (max. of two GFI receptacles per pedestal)

**Note:** 20 A GFI receptacles are not to be used for shore power.

- Single or dual Cat5 high-speed Internet connections
- Single or dual water 1/4-turn ball valves with 3/4-inch hose bibs and stainless steel handles
- Digital metering available
- Wireless remote metering available for water and electricity
- LED lighting



Catalog Number Selection

A D U 4 7 0 0 0 0 0 1 2 K M

Type	
<b>A</b>	Admiral-SS

Lighting and Lens Color	
<b>A</b>	7 W light Amber
<b>B</b>	Dual 7 W light Amber
<b>C</b>	9 W light Amber
<b>D</b>	13 W light Amber
<b>E</b>	Dual 13 W light Amber
<b>F</b>	No lighting Amber
<b>G</b>	7 W light Clear
<b>H</b>	Dual 7 W light Clear
<b>I</b>	9 W light Clear
<b>J</b>	13 W light Clear
<b>K</b>	Dual 13 W light Clear
<b>L</b>	No lighting Clear
<b>M</b>	7 W light Special
<b>N</b>	Dual 7 W light Special
<b>O</b>	9 W light Special
<b>P</b>	13 W light Special
<b>Q</b>	Dual 13 W light Special
<b>R</b>	No lighting Special
<b>S</b>	350 MA LED Amber
<b>T</b>	700 MA LED Amber
<b>U</b>	350 MA LED Clear
<b>V</b>	700 MA LED Clear
<b>W</b>	350 MA LED Special
<b>Y</b>	700 MA LED Special

Metering Type	
<b>U</b>	Unmetered
<b>D</b>	Digital electronic meters (side one)
<b>T</b>	Digital electronic meters (side two)
<b>B</b>	Digital electronic meters (both sides)
<b>M</b>	One meter socket (100 A)
<b>N</b>	Two meter socket (100 A each)
<b>V</b>	200 A meter socket

Sides and Receptacles							
R1S1	R2S1	R3S1	R4S1	R1S2	R2S2	R3S2	R4S2
0	0	0	0	0	0	0	0
1	1	1	1	1	1	1	1
2	2	2	2	2	2	2	2
3	3	3	3	3	3	3	3
4	4	4	4	4	4	4	4
5	5	5	5	5	5	5	5
6	6	6	6	6	6	6	6
7	7	7	7	7	7	7	7
8	8	8	8	8	8	8	8

Water Option ①	
<b>0</b>	= 0
<b>1</b>	= 1
<b>2</b>	= 2
<b>3</b>	= Single water meter
<b>4</b>	= Dual water meter
<b>5</b>	= Single meter, 2 V

Extra Unmetered GFI Receptacles	
<b>0</b>	= None
<b>1</b>	= 1
<b>2</b>	= 2

Phone Cable TV and Internet Options		
Phone Jack	Cable TV Jack	Internet Option ②
<b>A</b>	= 1	0
<b>B</b>	= 1	0
<b>C</b>	= 1	0
<b>D</b>	= 1	1
<b>E</b>	= 1	1
<b>F</b>	= 1	1
<b>G</b>	= 1	2
<b>H</b>	= 1	2
<b>I</b>	= 1	2
<b>J</b>	= 2	0
<b>K</b>	= 2	0
<b>L</b>	= 2	0
<b>M</b>	= 2	1
<b>N</b>	= 2	1
<b>O</b>	= 2	1
<b>P</b>	= 2	2
<b>Q</b>	= 2	2
<b>R</b>	= 2	2
<b>S</b>	= 0	2
<b>T</b>	= 0	1
<b>U</b>	= 0	2
<b>V</b>	= 0	1
<b>W</b>	= 0	1
<b>X</b>	= 0	2
<b>Y</b>	= 0	2
<b>Z</b>	= 0	1
<b>0</b>	= 0	0

Bus	
<b>S</b>	= Single-phase 3/8-inch copper busbar
<b>F</b>	= Three-phase 3/8-inch copper busbar
<b>C</b>	= Single-phase 3/8-inch Canadian busbar
<b>T</b>	= Three-phase 3/8-inch Canadian busbar
<b>M</b>	= Single-phase 300 kcmil mechanical lug bus
<b>Z</b>	= Three-phase 300 kcmil mechanical lug bus
<b>L</b>	= Single-phase 350 kcmil mechanical lug bus
<b>P</b>	= Three-phase 350 kcmil mechanical lug bus
<b>N</b>	= Single-phase 1/4-inch copper busbar
<b>Q</b>	= Single-phase 1/4-inch split mechanical busbar
<b>D</b>	= Dual-phase busbar

Receptacles: R1S1 = Receptacle 1, Side 1  
 R2S1 = Receptacle 2, Side 1  
 R3S1 = Receptacle 3, Side 1  
 R4S1 = Receptacle 3, Side 1  
 R1S2 = Receptacle 1, Side 2  
 R2S2 = Receptacle 2, Side 2  
 R3S2 = Receptacle 3, Side 2  
 R4S2 = Receptacle 3, Side 2

**Notes**  
 ① Number represents the quantity of 1/4-turn ball valves with 3/4-inch hose bibs.  
 ② Number represents the quantity of RJ-45 high-speed Internet jacks.  
 Internet option also available. Contact factory for details.

# 5.5

## Power Pedestals

### Marina Power and Lighting Equipment

#### Accessories

See Page V1-T5-75.

#### Dimensions

Approximate Dimensions in Inches (mm)

#### Admiral-SS

5

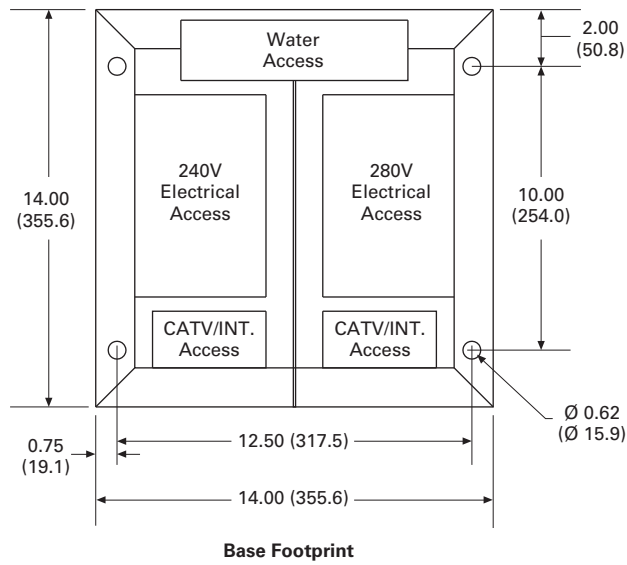
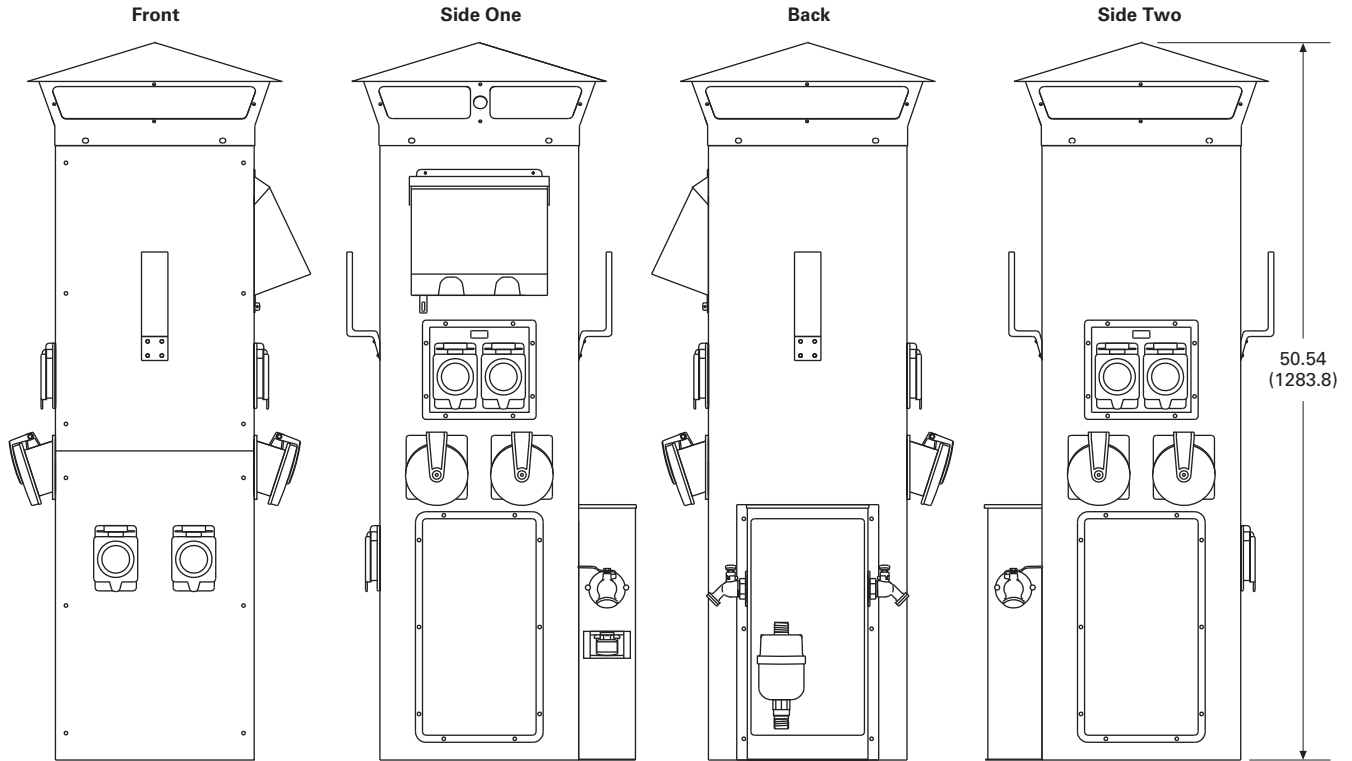

Newport Harbor Mate



## Newport Harbor Mate

### Product Description

Five years of development and 30 prototype models have yielded this unit the most innovative mini-power center available. Host to a variety of electrical services, contained in a compact yet strong housing, the Newport Harbor Mate is packed with features.

### Features, Benefits and Functions

- Tough and durable resin housing with UV inhibitor for lasting finish
- Photocell controlled 7 and 9 watt fluorescent light (clear lens or amber lens for bug reduction)
- Designed to mount on a dock box, piling or stainless steel stand
- Copper busbar with a maximum rating of 140 A

## Contents

<i>Description</i>	<i>Page</i>
Power Pedestals . . . . .	V1-T5-51
Lighthouse . . . . .	V1-T5-54
Lighthouse-SS . . . . .	V1-T5-58
Admiral-SS . . . . .	V1-T5-62
Newport Harbor Mate	
Available Options . . . . .	V1-T5-66
Catalog Number Selection . . . . .	V1-T5-67
Accessories . . . . .	V1-T5-68
Dimensions . . . . .	V1-T5-68
Hatteras Light . . . . .	V1-T5-69
Firehouse . . . . .	V1-T5-73
Smart Start . . . . .	V1-T5-79
Mariner . . . . .	V1-T5-80
Digital Electronic Kilowatthour Meters . . . . .	V1-T5-81
Distribution Equipment—Ground Fault Monitor . . . . .	V1-T5-82
Distribution Equipment—Mega Yacht Powerpoint . . . . .	V1-T5-83
Distribution Equipment—Substations. . . . .	V1-T5-86
Distribution Equipment—Panels . . . . .	V1-T5-89
Distribution Equipment—Transformers. . . . .	V1-T5-90

# 5.5

## Power Pedestals

### Marina Power and Lighting Equipment

5

#### Newport Harbor Mate (Shown with Optional Stand)

Tough and durable resin housing with UV inhibitor for lasting finish

Available with single, dual or combo of 30 or 50 A receptacles  
20 A / 125 V GFI receptacle  
Phone, cable TV, high-speed Internet connections  
Digital electronic meter

Lockable weatherproof door that protects receptacles and breakers

Photocell controlled 7 watt fluorescent light with amber lens for bug reduction

Single or dual 1/2-turn brass ball valve with 3/4-inch hose bibs

Stainless steel stand

Designed to mount on a dock box, piling, wall or optional stand (shown in photo)



#### Available Options

- Available with single, dual or combination of 30 A or 50 A receptacles
- 20 A / 125 V GFI receptacle (max. of two GFI receptacles per pedestal)

**Note:** 20 A GFI receptacles are not to be used for shore power.

- Single or dual phone, cable TV, high-speed Internet connections
- Electronic metering (one or two element meters available)
- 316L stainless steel stand
- LED lighting



**Mounting Option**



**Backlit Faceplate**

Catalog Number Selection

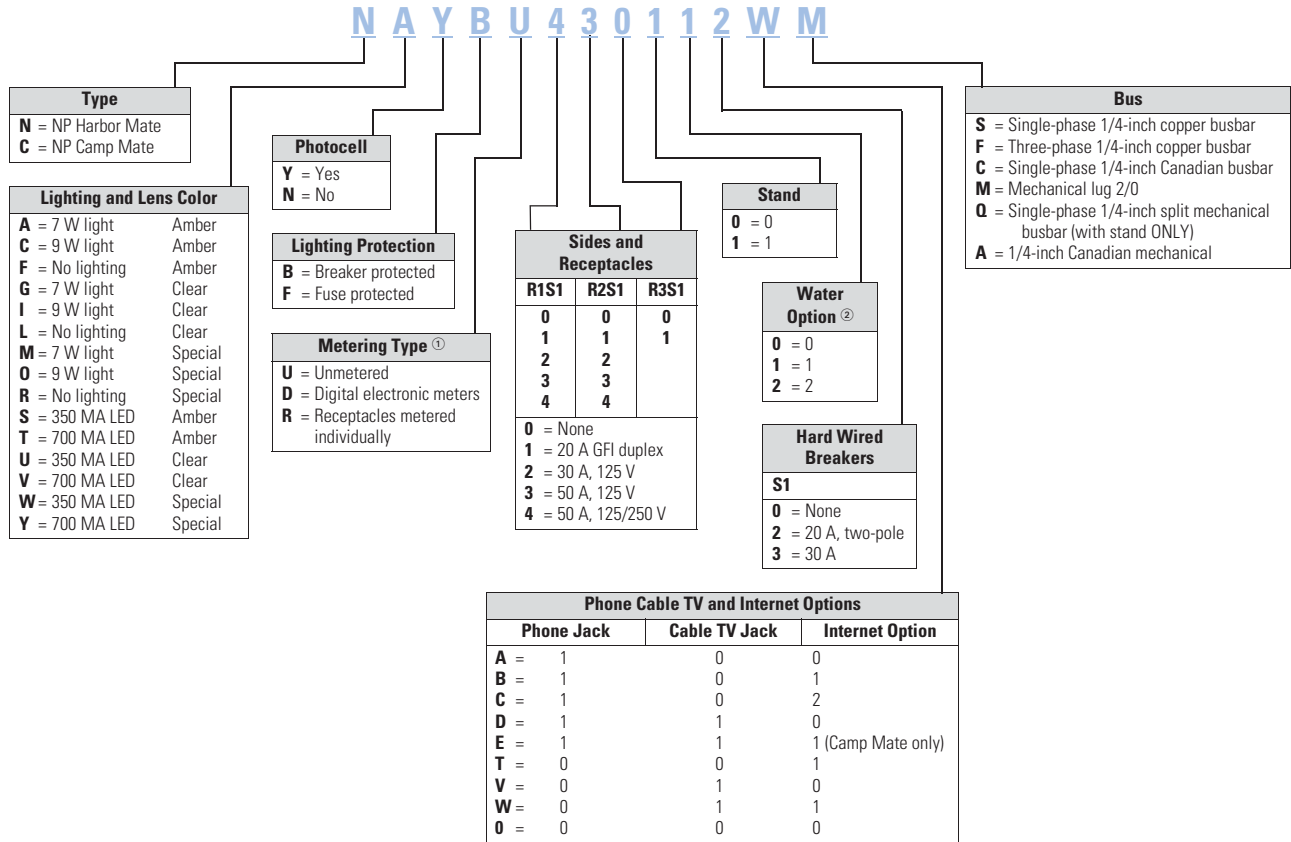

Receptacles: R1 = Receptacle 1  
R2 = Receptacle 2

**Notes**

- ① 20 A GFIs not metered.
- ② Number represents the quantity of 1/4-turn ball valves with 3/4-inch hose bibs (with stand only).

#### Accessories

See Page V1-T5-75.

#### Dimensions

Approximate Dimensions in Inches (mm)

#### Newport Harbor Mate

5

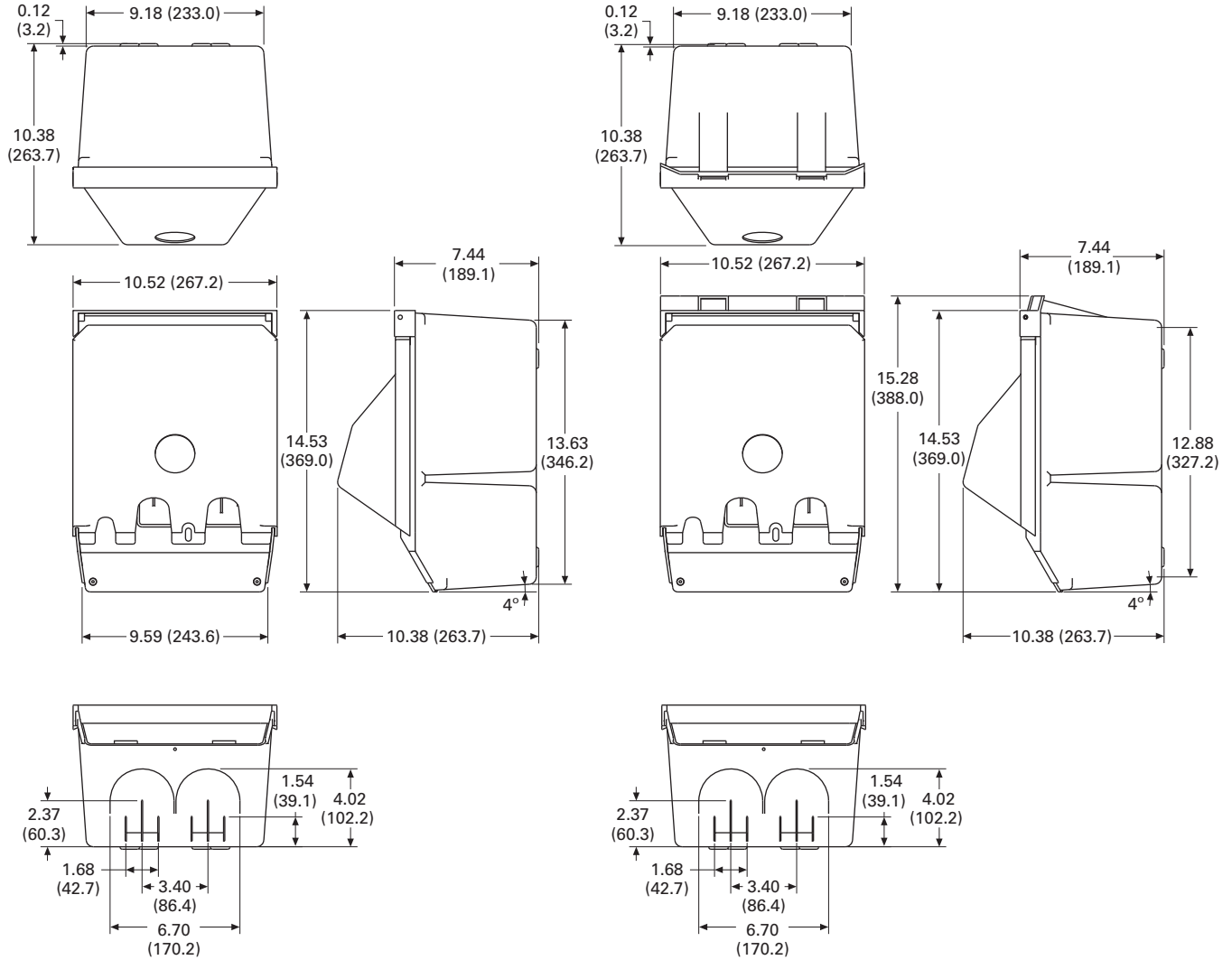

Newport Redesign

Newport Redesign With Meters

Hatteras Light



**Hatteras Light**

**Product Description**

The Hatteras® Light is an elegant and low cost alternative to the Lighthouse. It uses the same 360 degree light assembly as the Lighthouse, yet is only 30 inches tall. Thousands of these attractive pedestals are found not only in marinas, but also around pools, deck areas, boardwalks and landscape areas. The housing will never rust or corrode and comes with a limited lifetime warranty. This unit is popular for smaller slips at marinas with the Lighthouse and for private docks.

**Note:** Wireless remote reading of electronic kilowatt meters.

**Note:** Clear lens.

**Note:** Custom paint color.

**Features, Benefits and Functions**

- Photocell controlled 13 watt fluorescent light (clear lens or amber lens for bug reduction)
- Circuit breakers
- Heavy resin housing with a two-part polyurethane coating for a UV resistant, long-lasting finish
- Copper busbar with a maximum rating of 140 A

**Contents**

<i>Description</i>	<i>Page</i>
Power Pedestals . . . . .	V1-T5-51
Lighthouse . . . . .	V1-T5-54
Lighthouse-SS . . . . .	V1-T5-58
Admiral-SS . . . . .	V1-T5-62
Newport Harbor Mate. . . . .	V1-T5-65
Hatteras Light	
Available Options . . . . .	V1-T5-70
Catalog Number Selection . . . . .	V1-T5-71
Accessories . . . . .	V1-T5-72
Dimensions . . . . .	V1-T5-72
Firehouse . . . . .	V1-T5-73
Smart Start . . . . .	V1-T5-79
Mariner . . . . .	V1-T5-80
Digital Electronic Kilowatthour Meters . . . . .	V1-T5-81
Distribution Equipment—Ground Fault Monitor . . . . .	V1-T5-82
Distribution Equipment—Mega Yacht Powerpoint . . . . .	V1-T5-83
Distribution Equipment—Substations. . . . .	V1-T5-86
Distribution Equipment—Panels . . . . .	V1-T5-89
Distribution Equipment—Transformers. . . . .	V1-T5-90

# 5.5

## Power Pedestals

### Marina Power and Lighting Equipment

#### Hatteras Light

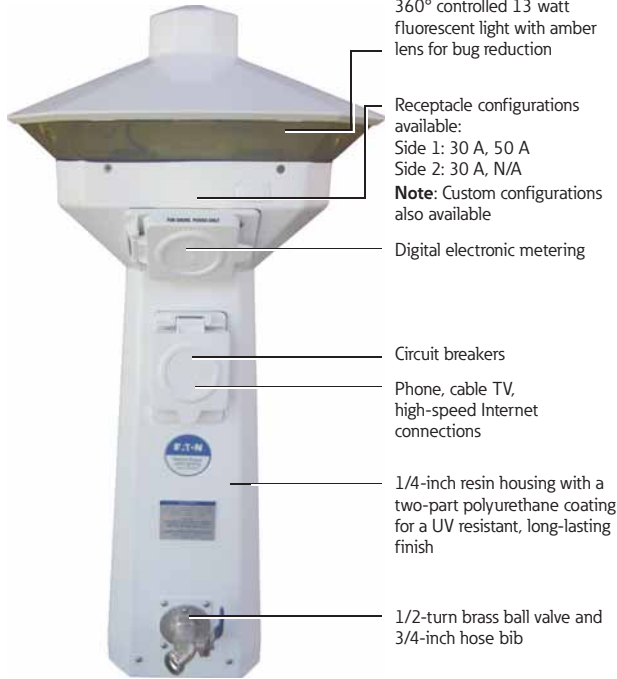

#### Available Options

- 20 A / 125 V GFI receptacle (max. of two GFI receptacles per pedestal)
- Note:** 20 A GFI receptacles are not to be used for shore power.
- Digital electronic metering (one or two element meter available)
- Single or dual phone, cable TV, high-speed Internet connections
- Single or dual 1/2-inch or 3/4-inch silcock with stainless steel handles
- LED lighting

5



**Copper Busbar with Ratings up to 140 A**



**20 A / 125 V GFI Receptacle**



**Faceplate**



Catalog Number Selection

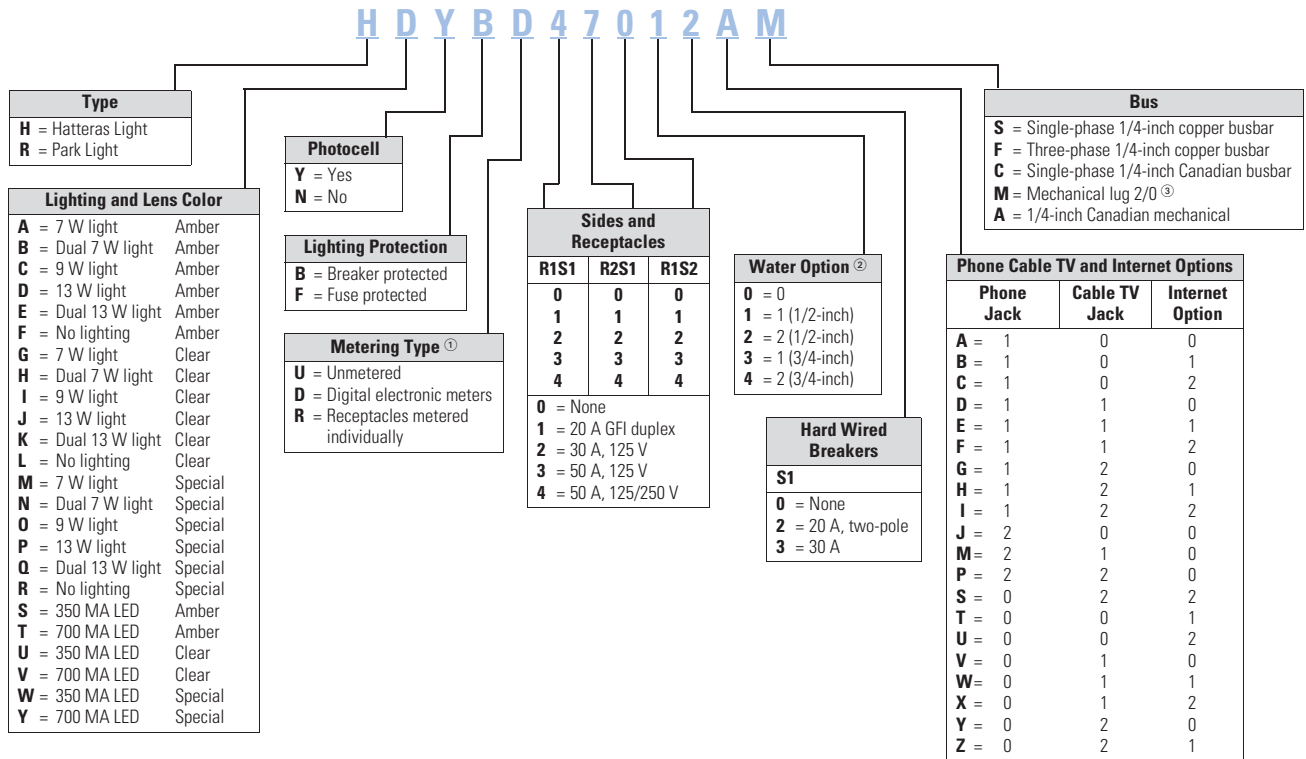

Receptacles: R1 = Receptacle 1  
R2 = Receptacle 2

**Notes**

- ① 20 A GFIs not metered.
- ② Number represents the quantity of 1/4-turn ball valves with 3/4-inch hose bibs.
- ③ Wire size #2/0 kcmil or less.

# 5.5

## Power Pedestals

Marina Power and Lighting Equipment

### Accessories

See Page V1-T5-75.

### Dimensions

Approximate Dimensions in Inches (mm)

### Hatteras

5

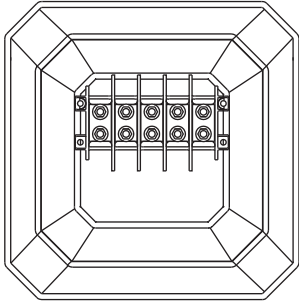

Busbar Access Top Removed

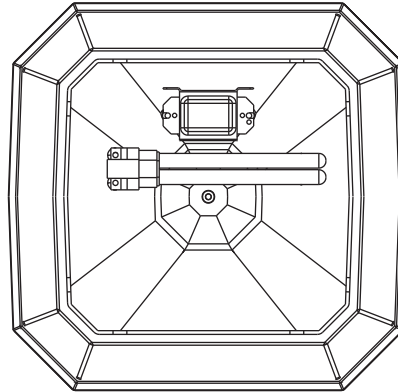

Inside Top

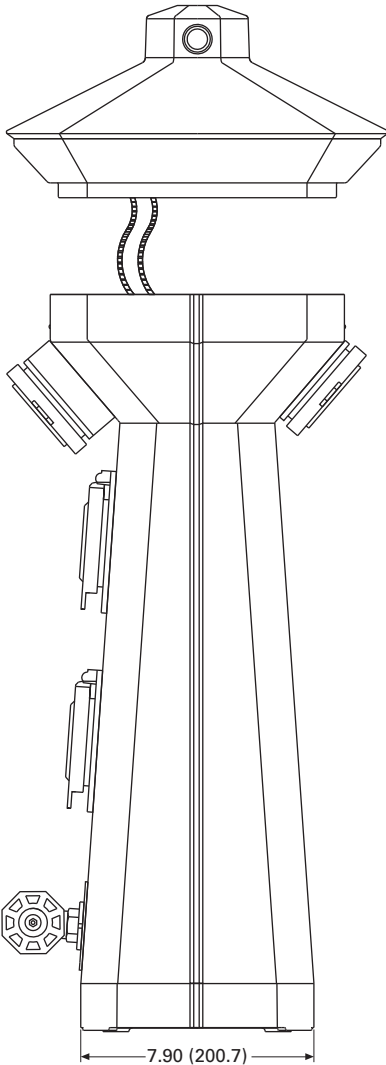

Side View

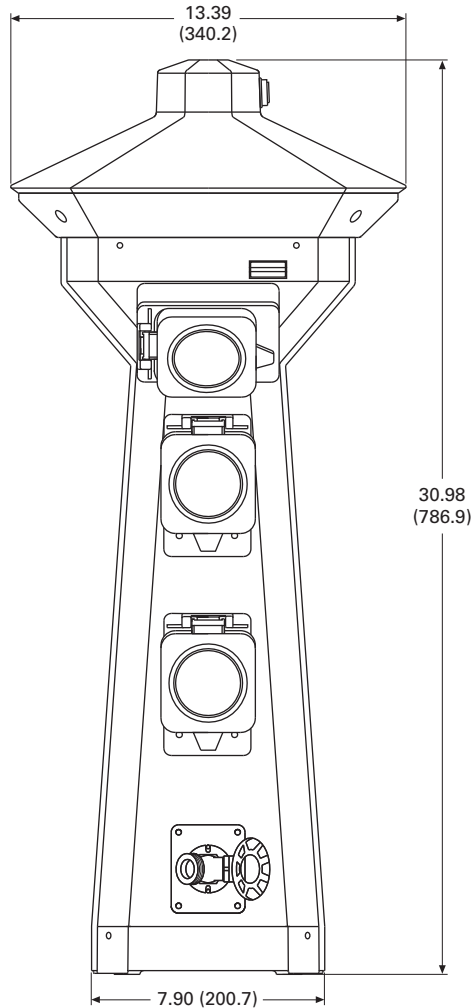

Front View

Firehouse



**Contents**

<i>Description</i>	<i>Page</i>
Power Pedestals . . . . .	<b>V1-T5-51</b>
Lighthouse . . . . .	<b>V1-T5-54</b>
Lighthouse-SS . . . . .	<b>V1-T5-58</b>
Admiral-SS . . . . .	<b>V1-T5-62</b>
Newport Harbor Mate . . . . .	<b>V1-T5-65</b>
Hatteras Light . . . . .	<b>V1-T5-69</b>
Firehouse	
Available Options . . . . .	<b>V1-T5-74</b>
Catalog Number Selection . . . . .	<b>V1-T5-74</b>
Accessories . . . . .	<b>V1-T5-75</b>
Dimensions . . . . .	<b>V1-T5-78</b>
Smart Start . . . . .	<b>V1-T5-79</b>
Mariner . . . . .	<b>V1-T5-80</b>
Digital Electronic Kilowatthour Meters . . . . .	<b>V1-T5-81</b>
Distribution Equipment—Ground Fault Monitor . . . . .	<b>V1-T5-82</b>
Distribution Equipment—Mega Yacht Powerpoint . . . . .	<b>V1-T5-83</b>
Distribution Equipment—Substations . . . . .	<b>V1-T5-86</b>
Distribution Equipment—Panels . . . . .	<b>V1-T5-89</b>
Distribution Equipment—Transformers . . . . .	<b>V1-T5-90</b>

**Firehouse**

**Product Description**

Created as a complete solution for fire and rescue needs, this pedestal features fire extinguisher storage and a mounted alarm strobe light and siren, as well as an optional life ring. This unit is well equipped for any marina emergency. The alarm strobe light and siren can be automatically activated when the door is open or optional life ring is removed.

**Features, Benefits and Functions**

- Alarm strobe light and siren: automatically activated when door is open or optional life ring is removed
- Photocell controlled 13 watt fluorescent light (clear lens or amber lens for bug reduction)
- 10 lb ABC Type fire extinguisher
- 316L stainless steel polyester powder-coated housing
- Polycarbonate top assembly

Firehouse

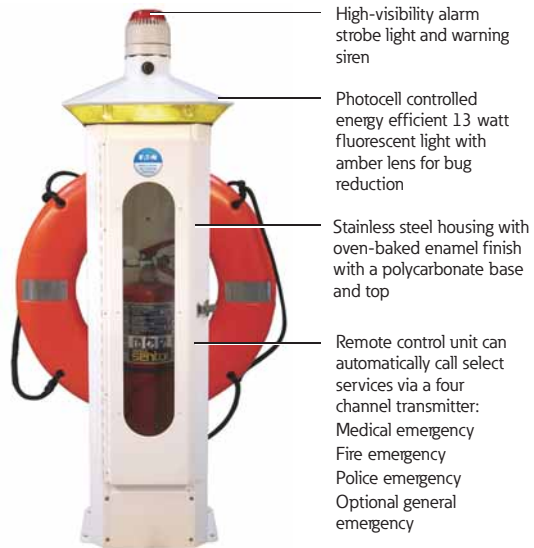

# 5.5

## Power Pedestals

### Marina Power and Lighting Equipment

#### Available Options

- 24-inch life ring
- 20 lb ABC Type fire extinguisher available

#### Catalog Number Selection

5

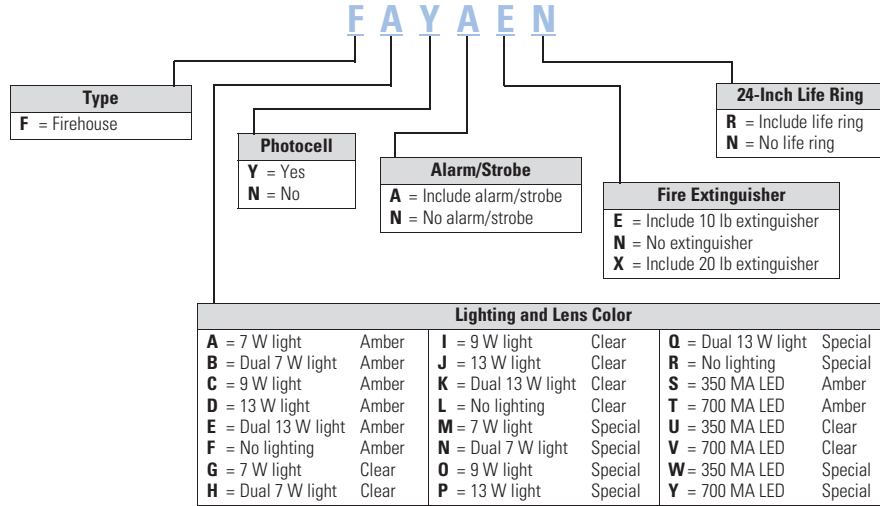

## Accessories

**Accessories for Custom Design Marina Products, Resin and Stainless Steel Pedestals and Power Products****Replacement Parts Catalog Numbers**

Description	Catalog Number
<b>Receptacles</b>	
20 A GFCI duplex	MPL3038
30 A 125 V twistlock	MPL3039
50 A 125 V twistlock	MPL3040
50 A 125/250 V twistlock	MPL3045
100 A 120/240 V pin and sleeve	MPL4100R12W
100 A 120/208 pin and sleeve	MPL5100R9W
100 A 480 V four-wire pin and sleeve	MPL4100R7W
100 A 480 V five-wire pin and sleeve	MPL5100R7W
200 A 277/480 V pin and sleeve (Russellstoll®)	MPL4200R7W
30 A 125 V RV	RV3042
50 A 125/250 V RV	RV3043
<b>Circuit Breakers</b>	
20 A 125 V single-pole	QCF1020
20 A 125 V single-pole GFCI	QCGF1020
30 A 125 V single-pole	QCF1030
30 A 125 V single-pole GFCI	QCGF1030
50 A 125 V single-pole	QCF1050
20 A 125/250 V two-pole	QCF2020
20 A 125/250 V two-pole GFCI	QCGF2020
30 A 125/250 V two-pole	QCF2030
30 A 125/250 V two-pole GFCI	QCGF2030
50 A 125/250 V two-pole	QCF2050
50 A 125/250 V two-pole GFCI	QCGF2050
60 A 125/250 V two-pole	QCF2060
100 A 125/250 V two-pole	GHC2100D
100 A 120/208 V three-pole	GHC3100D
200 A 277/480 V three-pole	JT2200FA
<b>Fluorescent Light Assembly</b>	
13 watt 120 V 60 Hz ballast	MPL2400
7 watt 120 V 60 Hz ballast	MPL2401
13 watt socket	MPL3079
7 watt socket	MPL3077
13 watt fluorescent bulb	MPL3018
7 watt fluorescent bulb	MPL3019
Photocell	MPL3044
Photocell nuts	MPL3034
Lighthouse in-line fuse	MPL3026
Lighthouse in-line fuse holder	MPL3027
<b>Lighthouse, Lighthouse-SS, Powerhouse, Powerhouse-SS, Hatteras, Park Light</b>	
Top with complete light and lens assembly	MPL6003A
Top with complete light and lens assembly—fused	MPL6003FA
Top only	MPL6003
Amber lens	MPL6005
Clear lens	MPL6008

**Replacement Parts Catalog Numbers, continued**

Description	Catalog Number
<b>Lighthouse, Lighthouse-SS, Powerhouse, Powerhouse-SS, Hatteras, Park Light, continued</b>	
20 A GFCI receptacle external cover set	MPL1101
30 A receptacle external cover set	MPL1102
50 A receptacle external cover set	MPL1105
Single-pole external breaker cover set	MPL11061
Two-pole external breaker cover set	MPL11062
Three-pole external breaker cover set	MPL11063
<b>Lighthouse, Lighthouse-SS, Powerhouse, Powerhouse-SS</b>	
Lighthouse/Powerhouse pedestal main housing	MPL6006
Lighthouse-SS/Powerhouse-SS pedestal main housing	MPL6006S
Lighthouse/Powerhouse main door	MPL6007
Lighthouse-SS/Powerhouse-SS main door	MPL6007S
Lighthouse/Powerhouse spring closure	MPL1099
Lighthouse Powerhouse top isolation plate	MPL6012
Lighthouse/Lighthouse-SS breaker plate	MPL1141
Powerhouse/Powerhouse-SS breaker plate	RV1112
Lighthouse/Lighthouse-SS/Powerhouse/Powerhouse-SS Hose and cable brackets	MPL1087
Lighthouse/Powerhouse stainless steel hinge	MPL1088
Lighthouse/Powerhouse complete pedestal base with busbar assembly	MPL6004A
Lighthouse/Powerhouse complete pedestal base with three-phase busbar assembly	MPL6004FA
Lighthouse/Powerhouse pedestal base without busbars	MPL6004
Lighthouse/Powerhouse aluminum blank access panel	MPL5500
Lighthouse/Lighthouse-SS/Powerhouse/Powerhouse-SS complete busbar assembly	MPL1140A
Lighthouse/Lighthouse-SS/Powerhouse/Powerhouse-SS complete three-phase busbar assembly	MPL1140FA
Copper busbar with nuts and washers	MPL3471
20 A GFCI—00 amber resin faceplate	MPL1120
30 A—20 GFCI amber resin faceplate	MPL1121
30—50 A amber resin faceplate	MPL1122
30—30 A amber resin faceplate	MPL1127
30—00 A amber resin faceplate	MPL1129
50—50 A amber resin faceplate	MPL1123
50 A—20 GFCI amber resin faceplate	MPL1124
20 GFCI—20 GFCI amber resin faceplate	MPL1125
00—00 amber resin faceplate	MPL1126
50 A—00 amber resin faceplate	MPL1128
100 A faceplate	MPL1142
20 A GFCI—00 amber resin faceplate assembly with breakers	MPL1120A
30 A—20 GFCI amber resin faceplate assembly with breakers	MPL1121A
30—50 A amber resin faceplate assembly with breakers	MPL1122A

## Replacement Parts Catalog Numbers, continued

Description	Catalog Number
<b>Lighthouse, Lighthouse-SS, Powerhouse, Powerhouse-SS, continued</b>	
30-30 A amber resin faceplate assembly with breakers	MPL1127A
50-50 A amber resin faceplate assembly with breakers	MPL1123A
50 A—20 GFCI amber resin faceplate assembly with breakers	MPL1124A
20 GFCI—20 GFCI amber resin faceplate assembly with breakers	MPL1125A
50 A—00 amber resin faceplate assembly with breakers	MPL1128A
30-00 A faceplate assembly with breakers	MPL1129A
100 A faceplate assembly with breakers	MPL1142A
Powerhouse 30-50 receptacle plate	RV1143
Powerhouse (30 A—00) receptacle plate	RV11433
Powerhouse (50 A—00) receptacle plate	RV11435
Powerhouse breaker plate	RV1112
<b>Phone, Cable, Internet Assemblies</b>	
Lighthouse/Powerhouse complete phone and cable assembly	MPL1114/RV1114
Lighthouse-SS/Powerhouse-SS/Hatteras Light/Park Light complete phone and cable assembly	MPL1119/RV1119
Hatteras Light/Park Light complete phone and cable assembly	MPL1119
Newport Harbor Mate/Camp Mate phone and cable insert assembly	MPL1115/RV1115
Lighthouse/Powerhouse access plates with dual Internet jacks	MPL5501
Coax cable TV FCF female adpt. with lugnut and washer	MPL1086
RJ45 CAT5e high-speed internet jack	MPL3059
Marine phone receptacle	MPL3037
RJ12 CAT3 phone jack	RV3060
<b>Water Assemblies</b>	
Lighthouse/Powerhouse complete water manifold assembly (dual 3/4-inch hose bibs with 1/4-turn ball valves)	MPL11A
Newport Harbor Mate/Newport Camp Mate water manifold assembly (dual 3/4-inch hose bibs with 1/4-turn ball valves)	MPL11C
3/4-inch hose adapter	MPL7030
Lighthouse/Powerhouse water mounting plate with mounting brackets	MPL1132
Hatteras Light/Park Light aluminum water mounting plate	MPL6584
1/2-inch brass silcock (hose bib)	MPL7014
3/4-inch stainless steel silcock (hose bib)	MPL5271
3/4-inch brass ball valve	MPL7021
Watts 3/4-inch backflow preventer	MPL7015

## Replacement Parts Catalog Numbers, continued

Description	Catalog Number
<b>Digital Electronic Meters</b>	
Single element, 14-pin quick disconnect (no CTs)	MPL17A1
Single element, 14-pin quick disconnect (with CTs)	MPL17A2 ①
Single element, 14-pin quick disconnect (with CTs)	MPL17A2 ②
Dual element, 14-pin quick disconnect (no CTs)	MPL17B1
Dual element, 14-pin quick disconnect (with CTs)	MPL17B2 ①
Dual element, 14-pin quick disconnect (with CTs)	MPL17B2 ②
Three element, 14-pin quick disconnect (no CTs)	MPL17C1
Three element, 14-pin quick disconnect (with CTs)	MPL17C2 ①
Three element, 14-pin quick disconnect (with CTs)	MPL17C2 ②
Single element coil transformers (CTs)	MPL30321 ①
Single element coil transformers (CTs)	MPL30321 ②
Dual element coil transformers (CTs)	MPL30322 ①
Dual element coil transformers (CTs)	MPL30322 ②
Three element coil transformers (CTs)	MPL30323 ①
Three element coil transformers (CTs)	MPL30323 ②
Counter (large—old style)	MPL3022
Counter (small—new style)	MPL3021
<b>Hatteras Light (Marina) and Park Light (RV) ③</b>	
Pedestal main housing	MPL6002
Copper busbar with nuts and washers	MPL3468
Complete busbar assembly	MPL1108A
Complete three-phase busbar assembly	MPL1108FA
20 A GFCI external cover door	MPL1101
30 A external cover door	MPL1102
50 A external cover door	MPL1105
Light fuse	MPL3026
Fuse holder	MPL3027
Mounting feet (set of four)	MPL7004

**Notes**

- ① Lighthouse, Lighthouse-SS, Powerhouse, Powerhouse-SS.  
 ② Hatteras Light, Park Light, Newport Camp Mate, Newport Harbor Mate.  
 ③ Please contact factory to determine configurations for replacement housing.

## Replacement Parts Catalog Numbers, continued

Description	Catalog Number
<b>Newport Harbor Mate (Marina) and Camp Mate (RV)</b>	
Amber lens—three-piece	MPL1117
Clear lens—three-piece	MPL1109
Main housing	MPL6000
Main door	MPL6001
30–30 A faceplate ①	MPL1135
30–50 A faceplate ①	MPL1136
50–50 A faceplate ①	MPL1137
50 A–00 faceplate ①	MPL1138
30 A–00 faceplate ①	MPL1139
30–30 A faceplate assembly with breakers ①	MPL1135A
30–30–20 GFI faceplate assembly ①	MPL1135G/RV1135G
30–50 A faceplate assembly with breakers ①	MPL1136A
30–50–20 GFI faceplate assembly ①	MPL1136G/RV1136G
50–50 A faceplate assembly with breakers ①	MPL1137A
50–50–20 GFI faceplate assembly ①	MPL1137G/RV1137G
50 A–00 faceplate assembly with breakers ①	MPL1138A
50–20 GFI faceplate assembly ①	MPL1138G/RV1138G
30 A–00 faceplate assembly with breakers ①	MPL1139A
30–20 GFI faceplate assembly ①	MPL1139G/RV1139G
Mounting brackets	MPL7005
36-inch stainless steel stand	MPL5506
Copper busbar with nuts and washers	MPL3468
Complete busbar assembly	MPL1108A
Complete three-phase busbar assembly	MPL1108FA
<b>Firehouse (Marina and RV)</b>	
Red strobe light/siren	MPL3020
Firehouse top with lighting assembly and strobe	MPLFH6003A
Light fuse	MPL3029
Fuse holder	MPL3028
Door	MPL6013
24-inch life ring	MPL4201
Life ring bracket	MPL4201B
Blank access panel	MPL6015
Door/life ring switch (pre-2004)	MPL3030
Door/life ring switch (new)	MPL3050
Door hasp	MPL3950
Busbar (double barrel terminal block)	MPL3751
10-lb ABC Type fire extinguisher	MPL8025
20-lb ABC Type fire extinguisher	MPL8025X

**Note**

① For custom faceplates to include phone/cable or other accessories, please contact Eaton's Marina Power & Lighting facility at 1-800-723-8009.

# 5.5

## Power Pedestals

### Marina Power and Lighting Equipment

#### Dimensions

Approximate Dimensions in Inches (mm)

#### Firehouse-SS

5

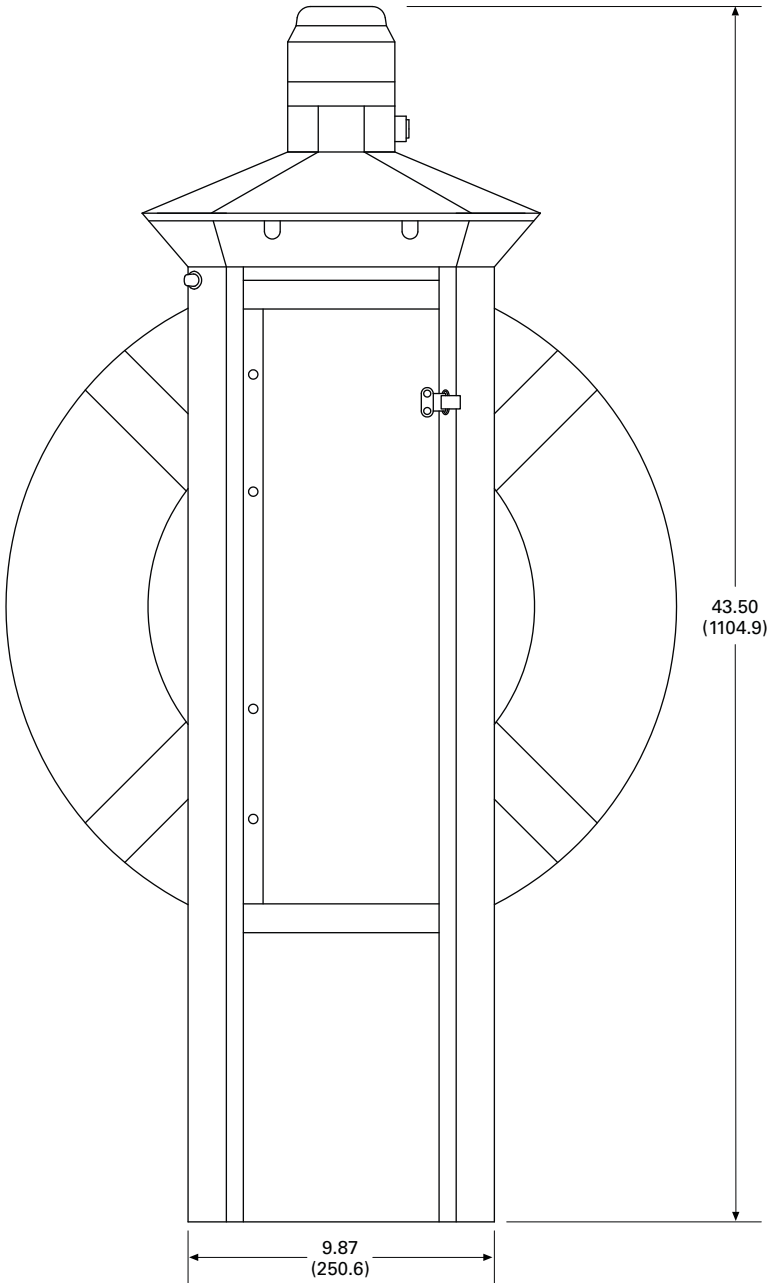



Smart Start



**Contents**

<i><b>Description</b></i>	<i><b>Page</b></i>
Power Pedestals . . . . .	<b>V1-T5-51</b>
Lighthouse . . . . .	<b>V1-T5-54</b>
Lighthouse-SS . . . . .	<b>V1-T5-58</b>
Admiral-SS . . . . .	<b>V1-T5-62</b>
Newport Harbor Mate. . . . .	<b>V1-T5-65</b>
Hatteras Light . . . . .	<b>V1-T5-69</b>
Firehouse . . . . .	<b>V1-T5-73</b>
Smart Start	
Mariner . . . . .	<b>V1-T5-80</b>
Digital Electronic Kilowatthour Meters . . . . .	<b>V1-T5-81</b>
Distribution Equipment—Ground Fault Monitor . . . . .	<b>V1-T5-82</b>
Distribution Equipment—Mega Yacht Powerpoint . . . . .	<b>V1-T5-83</b>
Distribution Equipment—Substations. . . . .	<b>V1-T5-86</b>
Distribution Equipment—Panels. . . . .	<b>V1-T5-89</b>
Distribution Equipment—Transformers. . . . .	<b>V1-T5-90</b>

**Smart Start**

**Product Description**

If you have transient boat slips, Eaton Marina Power and Lighting has developed their newest product for your situation.

The new “Smart Start” pedestal is activated by the swipe of a credit card. A kiosk will be centrally located at the marina and will control up to 32 power pedestals. When a boater wants to use a slip, they will enter the slip number and amount of time they would like and will then be asked to swipe a card in order to activate the pedestal. Once the chosen time is up, the pedestal will shut down. No more free power!

The “Smart Start” pedestal will not only prevent transient boaters from stealing power, but it will also eliminate the need for 24-hour monitoring of the slips. Boaters will be able to come in at any time of the day and activate a pedestal.

**Features**

- Lighted 316L stainless steel kiosk enclosure
- Programmable slip time blocks
- Programmable slip rates printable receipts

**Standards and Certifications**

- UL listing pending



**Dimensions**

Approximate Dimensions in Inches (mm)

<b>Smart Start</b>	
Height	60.05 (1525.3)
Width	14.15 (359.4)
Depth	14.24 (361.9)

Marina Power and Lighting Equipment



Mariner

5

### Mariner

#### Product Description

The Mariner is a lighting bollard that can stand from 1.5 to 4 feet tall and can be used in various applications from marina docks, to landscaped areas, golf courses and beyond. The Mariner will have a lifetime warranty on the engineered resin housing that will withstand the harsh marine and land environments from Alaska to the tropics.

#### Features

- Can be configured with a 7 watt, 9 watt or 13 watt fluorescent bulb
- Mounting base and painted pole supplied for desired height
- Limited lifetime warranty on engineered resin housing
- Custom colors available
- Side-mounted option

### Contents

#### Description

<i>Description</i>	<i>Page</i>
Power Pedestals . . . . .	<b>V1-T5-51</b>
Lighthouse . . . . .	<b>V1-T5-54</b>
Lighthouse-SS . . . . .	<b>V1-T5-58</b>
Admiral-SS . . . . .	<b>V1-T5-62</b>
Newport Harbor Mate . . . . .	<b>V1-T5-65</b>
Hatteras Light . . . . .	<b>V1-T5-69</b>
Firehouse . . . . .	<b>V1-T5-73</b>
Smart Start . . . . .	<b>V1-T5-79</b>
Mariner	
Digital Electronic Kilowatthour Meters . . . . .	<b>V1-T5-81</b>
Distribution Equipment—Ground Fault Monitor . . . . .	<b>V1-T5-82</b>
Distribution Equipment—Mega Yacht Powerpoint . . . . .	<b>V1-T5-83</b>
Distribution Equipment—Substations . . . . .	<b>V1-T5-86</b>
Distribution Equipment—Panels . . . . .	<b>V1-T5-89</b>
Distribution Equipment—Transformers . . . . .	<b>V1-T5-90</b>

#### Dimensions

Approximate Dimensions in Inches (mm)

##### Mariner

7 watt	14.15 (359.4)
9 watt/13 watt	14.24 (361.9)

##### Mounting Base and Pole

1.5 feet–4 feet
-----------------

#### Catalog Number Selection

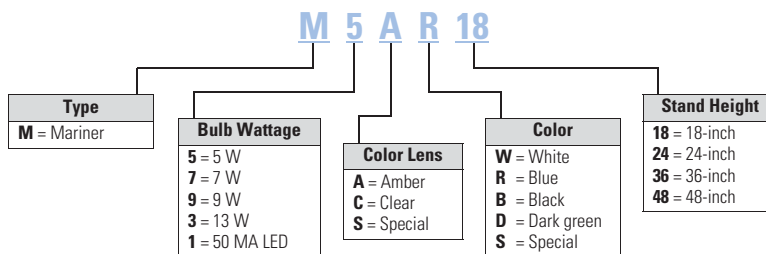

Digital Electronic Kilowatt Hour Meters



Contents

<i>Description</i>	<i>Page</i>
Power Pedestals . . . . .	V1-T5-51
Lighthouse . . . . .	V1-T5-54
Lighthouse-SS . . . . .	V1-T5-58
Admiral-SS . . . . .	V1-T5-62
Newport Harbor Mate. . . . .	V1-T5-65
Hatteras Light . . . . .	V1-T5-69
Firehouse . . . . .	V1-T5-73
Smart Start . . . . .	V1-T5-79
Mariner . . . . .	V1-T5-80
Digital Electronic Kilowatthour Meters	
Distribution Equipment—Ground Fault Monitor . .	V1-T5-82
Distribution Equipment—Mega Yacht Powerpoint	V1-T5-83
Distribution Equipment—Substations. . . . .	V1-T5-86
Distribution Equipment—Panels. . . . .	V1-T5-89
Distribution Equipment—Transformers. . . . .	V1-T5-90

Digital Electronic Kilowatthour Meters

Product Description

Using the latest surface mount technology, Eaton manufactures a digital electronic kilowatthour meter that exceeds the +/- 2% accuracy required by ANSI (American National Standards Institute) C-12.1 and is approved by the state of California at +/- 1% over the full range of 0–100 A from a 0.5–1 power factor and is available for both single- and three-phase applications.

The meter drives an electro-mechanical counter that requires a 12 V pulse each tenth of a kilowatthour, providing 10 pulses per kilowatt used. The meter output can be hard wired or connected to a transmitter in the pedestal for wireless transmission to a receiver displaying the output on a PC for direct billing of up to 1,000 individual customers.

Features

Our meter is designed to be user friendly in that all connections from external sources and the meter output are through one 14-pin locking connector. This feature eliminates many common problems, such as reverse line polarity and improper coil polarity. Simple LEDs, both red and green, indicate line and load condition and the pulsed LED indicates the rate of power consumption.

Wireless System

All of our meters are “wireless capable” to allow for wireless meter reading. This technology enables the marina or RV park to get meter readings from one central location rather than visiting every site to read the counters.

Meter Socket Capabilities

Meter sockets are available on the Lighthouse and Lighthouse-SS.

Standard

- Four jaw
- Ring-type
- 100 A

Available Options

- 200 A (SS only)
- Lockable hasp
- Ringless (SS only)
- Five jaw
- Seven jaw (SS only)

Product Selection



One Element Meter



Two Element Meter



Three Element Meter

#### Ground Fault Monitor



5

#### Contents

<i>Description</i>	<i>Page</i>
Power Pedestals . . . . .	V1-T5-51
Lighthouse . . . . .	V1-T5-54
Lighthouse—SS . . . . .	V1-T5-58
Admiral—SS . . . . .	V1-T5-62
Newport Harbor Mate . . . . .	V1-T5-65
Hatteras Light . . . . .	V1-T5-69
Firehouse . . . . .	V1-T5-73
Smart Start . . . . .	V1-T5-79
Mariner . . . . .	V1-T5-80
Digital Electronic Kilowatt-hour Meters . . . . .	V1-T5-81
Distribution Equipment—Ground Fault Monitor . . . . .	
Distribution Equipment—Mega Yacht Powerpoint . . . . .	V1-T5-83
Distribution Equipment—Substations . . . . .	V1-T5-86
Distribution Equipment—Panels . . . . .	V1-T5-89
Distribution Equipment—Transformers . . . . .	V1-T5-90

#### Distribution Equipment—Ground Fault Monitor

##### Product Description

Our ground fault monitoring systems are designed to detect fault currents in the AC shore power system that are too low to trip a circuit breaker. The ground fault monitor helps reduce the risk of injury or property damage that may result from stray fault currents. Our ground fault monitoring system provides information to the maintenance staff on the overall condition of the AC electrical system. The ground fault monitoring system operates 24 hours a day and can be monitored by non-technical personnel.

##### Features

- Adjustable trip level 10 mA to 10 A
- Current transformers up to 8 1/4-inch diameter
- Visual and/or audible alarm
- Housing of fiberglass or powder-coated stainless steel available

##### Power Guard

The ground fault monitor detects ground fault currents by means of current transformers (CT), which are placed around main or branch circuits. If a ground fault occurs, the CT will detect the amount of fault current and send a signal to the ground fault monitoring device where the amount of fault current is displayed with the faulty circuit identified. The detected fault can either activate an indicator alarm or disconnect the faulted circuit.

##### Standards and Certifications

- UL listed current transformers



Marina Power and Lighting Equipment

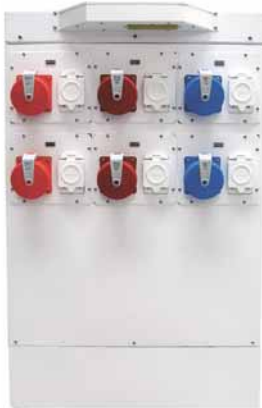

Contents

<i>Description</i>	<i>Page</i>
Power Pedestals . . . . .	V1-T5-51
Lighthouse . . . . .	V1-T5-54
Lighthouse-SS . . . . .	V1-T5-58
Admiral-SS . . . . .	V1-T5-62
Newport Harbor Mate . . . . .	V1-T5-65
Hatteras Light . . . . .	V1-T5-69
Firehouse . . . . .	V1-T5-73
Smart Start . . . . .	V1-T5-79
Mariner . . . . .	V1-T5-80
Digital Electronic Kilowatthour Meters . . . . .	V1-T5-81
Distribution Equipment—Ground Fault Monitor . . . . .	V1-T5-82
Distribution Equipment—Mega Yacht Powerpoint Wiring Diagram . . . . .	V1-T5-84
Dimensions . . . . .	V1-T5-85
Distribution Equipment—Substations . . . . .	V1-T5-86
Distribution Equipment—Panels . . . . .	V1-T5-89
Distribution Equipment—Transformers . . . . .	V1-T5-90

**Distribution Equipment—Mega Yacht Powerpoint**

**Product Description**

From the company that is known for its high-quality innovations, Eaton is the only company to offer a self-contained dual-phase mega yacht unit. Made out of long-lasting stainless steel, this mega yacht unit has a copper-wound, low-noise transformer that is double insulated and epoxy overcoated. The mega yacht unit delivers both single-phase and three-phase power to serve most mega yachts. Helping to keep your marina environment tranquil, the mega yacht unit has a low-noise, highly efficient transformer that has isolation mounts to ensure a very quiet operation.

**Features**

- Thermostatically controlled fans in transformer compartment for cooling
- Heavy stainless steel (316L) cabinet with a polyester powder coating
- Ventilated sun shields to help unit run cooler in tropical climates
- Limited lifetime warranty on housing
- Two or three light 13 watt photocell controlled fluorescent lights on the sun shield for optimal night lighting

**Available Options**

- 200 A–480 V three-phase receptacles
- 100% rated breakers
- Hard wiring busbars for all voltages with breaker protection
- Two 3/4 inch water outlets with a water meter
- Two phone, two CATV and two CAT5 high-speed Internet connections
- Digital electronic meters on all receptacles
- Primary breaker
- Two 480 V delta or wye 125 A three-phase receptacles (IEC)
- Two 120/208 V 100 A three-phase receptacles (IEC)
- Two 120/240 V 100 A single-phase receptacles (IEC)
- Up to four 50 A 120/240 V locking receptacles (NEMA)
- Up to four 30 A 120 V locking receptacles (NEMA)
- Wireless remote metering for electric and water
- 20 A GFI receptacle
- Primary side 480 V maximum 600 A
- Secondary side single-phase 120/240 V maximum 100 kVA
- Secondary side three-phase 120/208 V maximum 125 kVA
- Fire extinguisher—10 or 20 lbs

# 5.5

## Power Pedestals

### Marina Power and Lighting Equipment

#### Wiring Diagram

#### Powerpoint

5

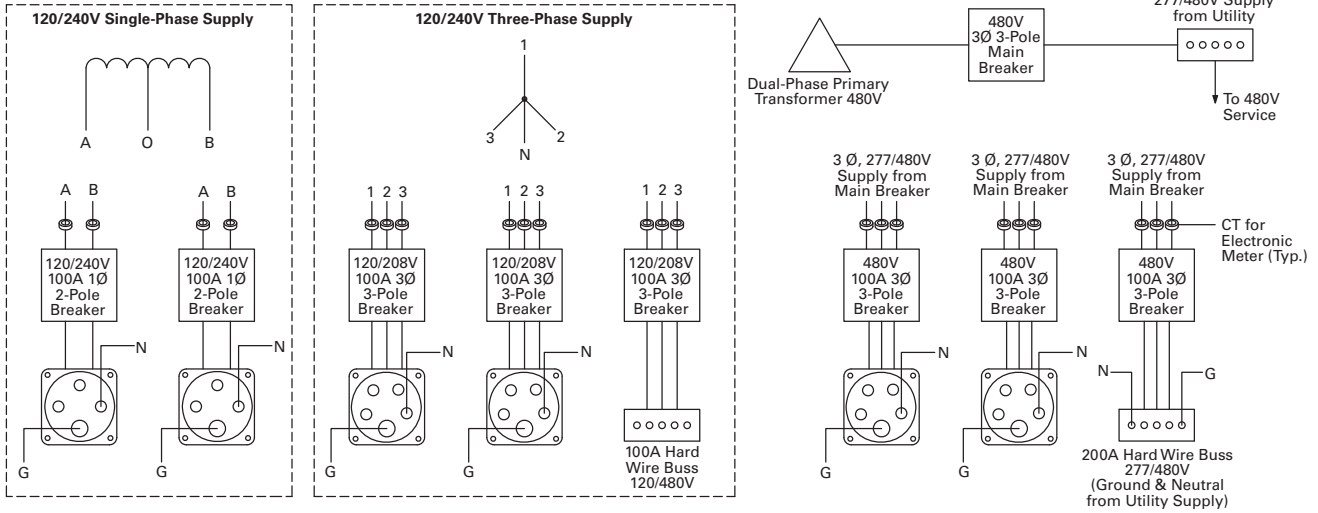

**Dimensions**

Approximate Dimensions in Inches (mm)

**Powerpoint Unit**

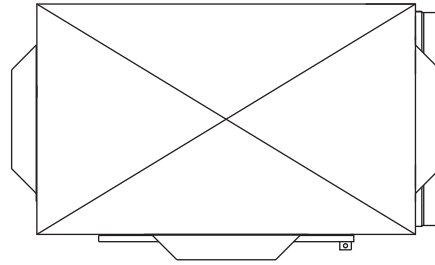

**Top With Solar Shield**

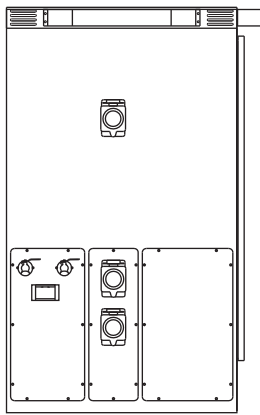

**Left Side**

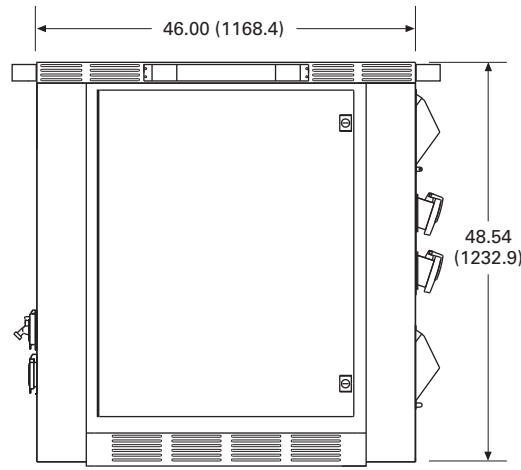

**Front**

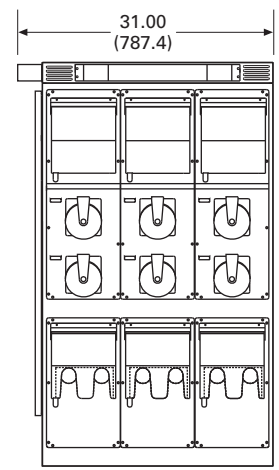

**Right Side**

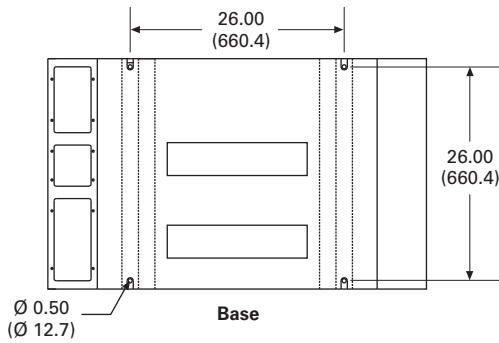

**Base**

#### Substations



**Double Panel Substation**

#### Contents

<i>Description</i>	<i>Page</i>
Power Pedestals . . . . .	<b>V1-T5-51</b>
Lighthouse . . . . .	<b>V1-T5-54</b>
Lighthouse-SS . . . . .	<b>V1-T5-58</b>
Admiral-SS . . . . .	<b>V1-T5-62</b>
Newport Harbor Mate . . . . .	<b>V1-T5-65</b>
Hatteras Light . . . . .	<b>V1-T5-69</b>
Firehouse . . . . .	<b>V1-T5-73</b>
Smart Start . . . . .	<b>V1-T5-79</b>
Mariner . . . . .	<b>V1-T5-80</b>
Digital Electronic Kilowatthour Meters . . . . .	<b>V1-T5-81</b>
Distribution Equipment—Ground Fault Monitor . . . . .	<b>V1-T5-82</b>
Distribution Equipment—Mega Yacht Powerpoint . . . . .	<b>V1-T5-83</b>
Distribution Equipment—Substations	
Features, Benefits and Functions . . . . .	<b>V1-T5-87</b>
Available Options . . . . .	<b>V1-T5-88</b>
Standards and Certifications . . . . .	<b>V1-T5-88</b>
Dimensions . . . . .	<b>V1-T5-88</b>
Distribution Equipment—Panels . . . . .	<b>V1-T5-89</b>
Distribution Equipment—Transformers . . . . .	<b>V1-T5-90</b>

#### Distribution Equipment—Substations

##### Product Description

The introduction of substations into the marina and recreational vehicle market allows Eaton to be your complete marina and RV park electrical products supplier. We are able to assist in the design and layout of your marina or RV park electrical system from the primary service provider, to your power pedestal. Our substations are designed for any coastal or inland environment and are constructed of powder-coated stainless steel NEMA 3R housing cabinets. All substation cabinets come with our limited lifetime warranty. All of our substations use Eaton's panels and circuit breakers providing our customers the utmost in circuit protection and quality.

##### Application Description

The aluminum and Galvaneal cabinets are recommended for inland applications. The substations can be configured with 50–330 kVA single-phase or three-phase copper wound transformers and up to 20 single-phase or 12 three-phase branch breakers. An optional three-sided double-wall cabinet is available that provides air flow between the panels. All substations come standard with temperature controlled cooling fans.

##### Product Selection Guide

##### Panel and Transformer Combinations

Panel	Transformer
<b>Single-Phase</b>	
200 A	50 kVA
300 A	75 kVA
400 A	100 kVA
600 A	150 kVA
700 A	167.5 kVA
800 A	200 kVA
1000 A	250 kVA
1200 A	330 kVA
<b>Three-Phase</b>	
100 A	45 kVA
200 A	75 kVA
300 A	112.5 kVA
400 A	150 kVA
600 A	225 kVA
800 A	300 kVA



**Features, Benefits and Functions**

- Limited lifetime warranty on the housing
- All stainless steel hardware
- Temperature controlled cooling fans in the transformer and circuit breaker compartments
- Lockable door

**Ventilation**

The substation ventilation is designed to optimize air circulation over and around the transformers and through the panel compartment so that the substation operates at lower temperatures.

Substations come equipped with temperature controlled cooling fans for exhausting hot air from the cabinet and solar shield.

In addition, substations are available with a double-walled cabinet and solar shield, which allow for cooling of both the exterior surface of the cabinet and the internal components.

**Substations**

Stainless steel housing with polyester powder coating



Limited lifetime warranty on the housing

Stainless steel hardware with locking doors

Temperature-controlled fans for cooling

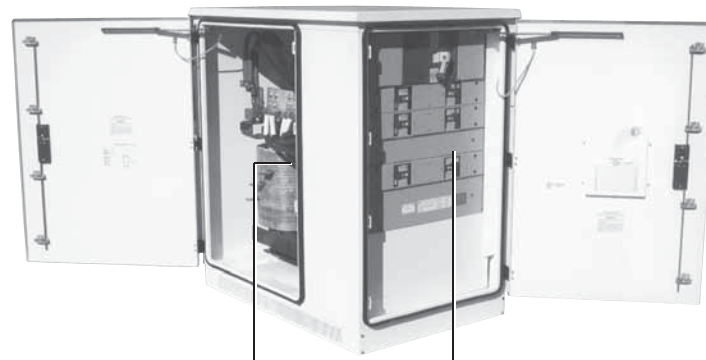

Custom made to your specifications: Single-phase or three-phase copper wound transformers 50 to 330 kVA

Up to 1200 A main circuit breaker with 20 single-phase or 12 three-phase branch circuit breakers

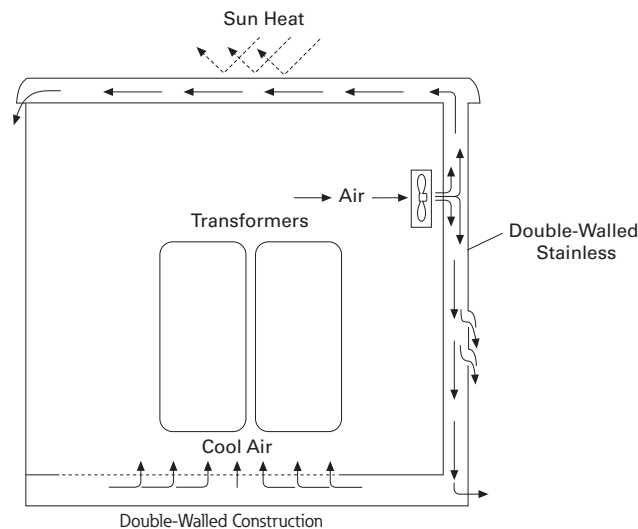

**Available Options**

- Powder-coated cabinets made of stainless steel or fiberglass
- Limited lifetime warranty on housing. Transformer and secondary distribution panel in a single enclosure have a one-year limited warranty
- Stainless steel housing and hardware with locking doors
- Single-phase and three-phase models
- Overload capacity meets ANSI L57.96–01.250
- Optional double-walled construction
- Temperature controlled fans for cooling
- Custom-made copper wound single-phase or three-phase transformers from 50–330 kVA
- Up to 1200 A main circuit breaker with 15 single-phase branch circuit breakers or 10 three-phase branch circuit breakers
- Substations can be equipped with photocells to turn on and off lights
- A 20 A GFI can be installed in the cabinet, as well as a ground fault monitoring system

**Standards and Certifications**

- cULus listed

**Dimensions**

Approximate Dimensions in Inches (mm)

**Substations****Standard Substation**

Height	53.00 (1346.2)
Width	51.00 (1295.4)
Depth	33.00 (838.2)

**Side-by-Side Substation**

Height	53.00 (1346.2)
Width	66.00 (1676.4)
Depth	30.00 (762.0)

**Double Panel Substation**

Height	53.00 (1346.2)
Width	63.00 (1600.2)
Depth	33.00 (838.2)

Panels



Panel (Stainless Steel Shown)

Contents

<i>Description</i>	<i>Page</i>
Power Pedestals . . . . .	V1-T5-51
Lighthouse . . . . .	V1-T5-54
Lighthouse-SS . . . . .	V1-T5-58
Admiral-SS . . . . .	V1-T5-62
Newport Harbor Mate . . . . .	V1-T5-65
Hatteras Light . . . . .	V1-T5-69
Firehouse . . . . .	V1-T5-73
Smart Start . . . . .	V1-T5-79
Mariner . . . . .	V1-T5-80
Digital Electronic Kilowatthour Meters . . . . .	V1-T5-81
Distribution Equipment—Ground Fault Monitor . . . . .	V1-T5-82
Distribution Equipment—Mega Yacht Powerpoint . . . . .	V1-T5-83
Distribution Equipment—Substations . . . . .	V1-T5-86
Distribution Equipment—Panels . . . . .	V1-T5-86
Distribution Equipment—Transformers . . . . .	V1-T5-90

Distribution Equipment—Panels

Product Description

Two of the many products we can offer our customers are Eaton’s PRL-3A and PRL-4 panels as standalone units or in one of our substations. All of our busses are made of copper and are load rated; breakers are bolt-on type. Distribution panels can be 120/240 V single-phase, 120/208 V three-phase, 277/480 V three-phase or 220Y/127 V three-phase based on your system requirements. Distribution panels can also have a main breaker or a main lug. Branch circuit breakers are provided based on customer requirements.

Features

- All internal wiring is fine stranded 1000 V insulated copper
- Copper busbars
- All exterior hardware is stainless steel

Available Options

- NEMA 3R or 4X
- Powder-coated stainless steel
- Main breaker up to 1200 A
- Branch breaker 20–1200 A
- Main lug only
- We also offer 480 V models—single-phase and three-phase

Standards and Certifications

- UL listed
- cULus listed



Single-Phase

- Up to 1200 A main circuit breakers
- Up to 42 branch circuit breakers

Three-Phase

- Up to 1200 A main circuit breakers
- Up to 42 branch circuit breakers

#### Transformers



Three-Phase Transformer

#### Contents

<i>Description</i>	<i>Page</i>
Power Pedestals . . . . .	V1-T5-51
Lighthouse . . . . .	V1-T5-54
Lighthouse-SS . . . . .	V1-T5-58
Admiral-SS . . . . .	V1-T5-62
Newport Harbor Mate . . . . .	V1-T5-65
Hatteras Light . . . . .	V1-T5-69
Firehouse . . . . .	V1-T5-73
Smart Start . . . . .	V1-T5-79
Mariner . . . . .	V1-T5-80
Digital Electronic Kilowatthour Meters . . . . .	V1-T5-81
Distribution Equipment—Ground Fault Monitor . . . . .	V1-T5-82
Distribution Equipment—Mega Yacht Powerpoint . . . . .	V1-T5-83
Distribution Equipment—Substations . . . . .	V1-T5-86
Distribution Equipment—Panels . . . . .	V1-T5-89
Distribution Equipment—Transformers . . . . .	

#### Distribution Equipment—Transformers

##### Product Description

Because of the high humidity and corrosive conditions of coastal environments, our transformers are wound with Class H heavily insulated copper bar and are double dipped in tough insulating varnish that protects the copper, as well as reduces the hum that is typical in a transformer that is not double dipped. We provide a second overcoat of high temperature epoxy to protect against the severe saltwater environment. We can provide this transformer in single-phase, from 50 to 500 kVA, and three-phase, from 45 to 300 kVA.

##### Features

- Copper wound transformer coils double dipped in high temperature baking varnish
- All internal wiring is fine stranded 2000 V insulated copper
- Copper busbars
- Marine transformers with epoxy overcoat
- All copper-to-copper connections

##### Available Options

- Single-phase: 50–500 kVA
- Three-phase: 45–300 kVA
- Epoxy overcoat for non-marine applications

##### Primary Voltages

- 480 wye three-phase
- 480 V three-phase delta three-wire + ground
- 480 V single-phase two-wire + ground

##### Secondary Voltages

- 127/220 V three-phase wye four-wire
- 120/208 V three-phase wye four-wire
- 120/240 V single-phase three-wire

##### Marina Power Distribution Transformer kVA Availabilities

- Single-phase: 50, 75, 100, 150, 167.5, 200, 250, 330, 500 kVA
- Three-phase: 45, 75, 112.5, 150, 225, 300 kVA

##### Standards and Certifications

- cULus listed



# Air Conditioning Disconnects

## Air Conditioning Disconnects



## 6.1 Air Conditioning Disconnects

Product Description . . . . .	V1-T6-2
Application Description . . . . .	V1-T6-2
Features, Benefits and Functions . . . . .	V1-T6-3
Standards and Certifications . . . . .	V1-T6-3
Product Selection . . . . .	V1-T6-4
Cross-Reference . . . . .	V1-T6-6
Technical Data and Specifications . . . . .	V1-T6-7
Dimensions . . . . .	V1-T6-7



# 6.1

## Air Conditioning Disconnects

Fused, Unfused and Molded Case Switch

### Air Conditioning Disconnects



*Complete Line of Fused, Unfused and Molded Case Switch Type Air Conditioning Disconnects*

6

### Contents

#### Description

	<i>Page</i>
Features, Benefits and Functions . . . . .	<b>V1-T6-3</b>
Standards and Certifications . . . . .	<b>V1-T6-3</b>
Product Selection . . . . .	<b>V1-T6-4</b>
Cross-Reference . . . . .	<b>V1-T6-6</b>
Technical Data and Specifications . . . . .	<b>V1-T6-7</b>
Dimensions . . . . .	<b>V1-T6-7</b>

### Product Description

An air conditioning disconnect (ACD) is a disconnect located between a loadcenter (distribution panel) and air conditioner. Eaton's ACD product line provides an installer or repair personnel with a visible disconnecting means when performing maintenance. ACDs are also known as disconnects, pullouts or air conditioning switches.

Non-fused pullout and molded case switch devices provide personnel with a visible ON-OFF disconnecting means. While fused pullout units also perform this function, they also provide an additional level of protection for the air conditioner.

Fused and non-fused devices are of a pullout design, where the user physically removes or "pulls out" a tab to break the electrical connection. A molded case switch is similar to a light switch where the user "switches" the unit to the indicated ON-OFF position.

#### Fused and Non-Fused Pullouts

- ON/OFF control provided by a pullout handle
- Pullout handle can be conveniently stored in the compartment in the OFF position, helping to prevent the handle from being misplaced
- Protective shield cannot be removed until the pullout handle is removed, disconnecting the power

#### Molded Case Switch

- Rugged molded case construction in a disconnect switch that looks like a circuit breaker but operates like an ordinary household light switch
- Plug-in molded case switch (included) eliminates the need for pullout handles
- No need for replacement pullout handles due to loss or theft

### Application Description

The most widely used application for ACDs is for residential and light commercial air conditioning units. An ACD is installed outdoors, in visible proximity to the air conditioner condensing unit. ACDs are also found in use with heat pumps, swimming pools, spas, whirlpools and pump houses, and meet 2008 NEC Article 422.31 (B) requirements for servicing electric water heaters. Metallic enclosures are galvanized steel and are installed in various locations. Non-metallic enclosures are a plastic (polycarbonate) enclosure commonly used in coastal or salt-water areas.

### Features, Benefits and Functions

- Single-phase, two-wire, 240 Vac and three-phase, three-wire, 240 Vac
- NEMA 3R outdoor enclosures offered in metallic and non-metallic versions
- Easy-to-remove high-strength protective shield for easier wiring and mounting
- Easy-to-remove front cover (no screws or fasteners to remove)
- 1-inch knockouts on the bottom, back and side of unit
- Copper-rated line and load lugs that are easily accessible
- Ample wiring space for mounting with a stud gun (single keyhole, two- or three-point mounting)
- Fused devices are service entrance rated
- Horsepower rated (10 hp maximum at 240 Vac)
- Padlockable door provision for safety and reduction of tampering
- Metallic enclosures are bottom entry and exit only
- Non-metallic enclosures have knockouts and a hub provision for top access
- Non-metallic enclosures have a single unit door and protective shield for installer convenience
- Non-metallic enclosures are durable and provide excellent resistance to climate changes
- Factory-installed tamper-resistant/weather-resistant receptacles are available as an option on some products

**Note:** Fused non-metallic units require the addition of **GB4NM** ground bar to obtain a Service Entrance rating.

### Standards and Certifications

- UL listed File No. E132354, E143893, E196365



Contact Eaton for details and part numbers for CSA approved units.

# 6.1

## Air Conditioning Disconnects

Fused, Unfused and Molded Case Switch

### Product Selection

#### DPU222R



#### Non-Fused Pullouts

Main Ampere Rating	Maximum hp Rating		Wire Size Range Cu/Al 60 °C or 75 °C	Catalog Number
	120 V	240 V		
<b>Galvanized Steel</b>				
60	—	10	#14-3	DPU222R ①
<b>Non-Metallic/Polycarbonate Enclosure</b>				
60	—	10	#14-2	ACD222URNM-A2 ①

#### DPF222R



#### Fused Pullouts

Main Ampere Rating	Maximum hp Rating		Wire Size Range Cu/Al 60 °C or 75 °C	Catalog Number
	120 V	240 V		
<b>Galvanized Steel</b>				
30 ②	2	3	#14-3	DPF221R ①
60 ②	3	10	#14-3	DPF222R ①
<b>Non-Metallic</b>				
30	2	3	#14-2	ACD221RNM-A2 ①
60	3	10	#14-2	ACD222RNM-A2 ①

For Service Entrance applications, see footnotes below.

#### DPB222R



#### Molded Case Switch

Main Ampere Rating	Maximum hp Rating		Wire Size Range Cu/Al 60 °C or 75 °C	Catalog Number
	120 V	240 V		
<b>Galvanized Steel</b>				
60	—	10	#14-3	DPB222R ③
<b>Non-Metallic/Polycarbonate Enclosure</b>				
60	—	10	#14-2	B60NARNM-A2 ③

#### Notes

- ① For replacement pullout head, order part number **96-3258-4**.
- ② To obtain a Service Entrance Rating, the addition of a **DPFG** (ground bar kit) is required.
- ③ For replacement molded case switch, order part number **BR260NA**.



**DPU222RGF20**



**ACD with 20 Ampere Ground Fault Receptacle** ①

Main Ampere Rating	Maximum hp Rating		Wire Size Range Cu/Al 60 °C or 75 °C	Catalog Number
	120 V	240 V		
<b>Non-Fused Pullouts</b>				
60	—	10	#14-3	<b>DPU222RGF20WTST</b> ②
60	—	10	#14-3	<b>DPU222RGF20ST</b>
<b>Fused Pullouts</b>				
30	2	3	#14-3	<b>DPF221RGF20WTST</b> ②
30	2	3	#14-3	<b>DPF221RGF20ST</b>
60	3	10	#14-3	<b>DPF222RGF20WTST</b> ②
60	3	10	#14-3	<b>DPF222RGF20ST</b>

**DPU222RGF15**



**ACD with 15 Ampere Ground Fault Receptacle** ①③

Main Ampere Rating	Maximum hp Rating		Wire Size Range Cu/Al 60 °C or 75 °C	Catalog Number
	120 V	240 V		
<b>Non-Fused Pullouts</b>				
60	—	10	#14-3	<b>DPU222RGF15ST</b>
60	—	10	#14-3	<b>DPU222RGF15WTST</b> ②
<b>Fused Pullouts</b>				
30	2	3	#14-3	<b>DPF221RGF15ST</b>
30	2	3	#14-3	<b>DPF221RGF15WTST</b> ②
60	3	10	#14-3	<b>DPF222RGF15ST</b>
60	3	10	#14-3	<b>DPF222RGF15WTST</b> ②

**Notes**

- ① Factory-installed GFCI receptacle.
- ② Includes weather-resistant/tamper-resistant receptacles to meet 2008 NEC Article 406.8 (A) and 406.11 requirements.
- ③ NEC permits the maximum receptacle rating of a 15 A circuit to be 15 A.

# 6.1

## Air Conditioning Disconnects

Fused, Unfused and Molded Case Switch

DPU362A



### Three-Phase Non-Fused ACD

Main Ampere Rating	Maximum hp Rating		Wire Size Range Cu 75 °C	Catalog Number
	240 V	480 V		
60	15	30	#14-4	DPU362RA

## 6

### Cross-Reference

#### Cross-Reference

Description	Catalog Number					
	Eaton	Square D®	GE®	Siemens® (Murray®)	Milbank	Midwest
<b>Metallic/Galvanized Steel Enclosure</b>						
30 A fused	DPF221R	—	TF30R	WF2030	U3830	U035F2
60 A fused	DPF222R	—	TF60R	WF2060	U3860	U065F1
60 A non-fused	DPU222R	—	TFN60R	—	U3800	U065P010
60 A non-fused compact design	DPU222R	—	—	WNFC2060	—	—
60 A molded case switch	DPB222R	QO200TR	TNA60R1	WNAS2060	—	U065NA1
60 A non-fused with ground fault receptacle	DPU222RGF20ST	—	TFN60RGFR	WN2060GFCL	U3822-20GR	U065P010
30 A fused with ground fault receptacle	DPF221RGF20ST	—	—	WF2030GFCL	—	U035F010
60 A fused with ground fault receptacle	DPF222RGF20ST	—	—	WF2060GFCL	—	U065F010
60 A non-fused with 1/2-inch wire harness	DPU222R12W ①	—	—	—	—	—
60 A non-fused with 3/4-inch wire harness	DPU222R34W ①	—	—	—	—	—
60 A three-phase 600 V molded case switch	DPU362RA	—	—	—	—	U0653F
<b>Non-Metallic/Polycarbonate Enclosure</b>						
30 A fused	ACD221RNM-A2	—	TPF30R	WF2030PL	—	P035F
60 A fused	ACD222RNM-A2	—	TPF60R	WF2060PL	—	P065F
60 A non-fused	ACD222URNM-A2	—	TPN60R1	WN2060PL	—	P065P1
60 A molded case switch	B60NARNM-A2	QO200TRNM	TPNA60R1	WNAS2060PL	—	P065NA1
30 A fused with 15 A ground fault receptacle	DPF221RGF15WRTRST	—	—	—	—	—
30 A fused with 20 A ground fault receptacle	DPF221RGF20WRTRST	—	—	—	—	—
60 A fused with 15 A ground fault receptacle	DPF222RGF15WRTRST	—	—	—	—	—
60 A fused with 20 A ground fault receptacle	DPF222RGF20WRTRST	—	—	—	—	—
60 A non-fused with 15 A ground fault receptacle	DPU222RGF15WRTRST	—	—	—	—	—
60 A non-fused with 20 A ground fault receptacle	DPU222RGF20WRTRST	—	—	—	U3822-20GWR	—

#### Note

① Eaton Quick Pro<sup>SM</sup> designated item.

### Technical Data and Specifications

- 10,000 amperes rms symmetrical interrupting rating
- Horsepower rated
- Fusible and non-fusible pullout and molded case switch designs
- 30 and 60 amperes available in fusible
- 60 amperes available in non-fusible and molded case switch
- Class H fuse clips provided on fusible pullout design
- WTST (weather-resistant/tamper-resistant with ground fault self-test) receptacle available

### Dimensions

Approximate Dimensions in Inches (mm)

#### Dimensions and Shipping Carton Information

Catalog Number	Carton Quantity	Dimensions in Inches (mm)			Weight Lbs (kg)
		Height	Width	Depth	
<b>Metallic/Galvanized Steel Enclosure</b>					
DPF221R	10	8.70 (220.9)	5.40 (137.2)	3.15 (80.0)	27 (12)
DPF222R	10	8.70 (220.9)	5.40 (137.2)	3.15 (80.0)	27 (12)
DPU222R	10	8.70 (220.9)	5.40 (137.2)	3.15 (80.0)	27 (12)
DPB222R	10	8.60 (218.4)	5.30 (134.6)	3.74 (95.0)	34 (15)
DPU222R12W <sup>Ⓢ</sup>	1	14.75 (374.6)	12.50 (317.5)	4.00 (101.6)	6 (3)
DPU222R34W <sup>Ⓢ</sup>	1	14.75 (374.6)	12.50 (317.5)	4.00 (101.7)	6 (3)
DPU222RGF20ST	1	13.00 (330.2)	7.50 (190.5)	4.75 (120.7)	8 (4)
DPF221RGF20ST	1	13.00 (330.2)	7.50 (190.5)	4.75 (120.7)	8 (4)
DPF222RGF20ST	1	13.00 (330.2)	7.50 (190.5)	4.75 (120.7)	8 (4)
DPU222RGF15ST	1	13.00 (330.2)	7.50 (190.5)	4.75 (120.7)	8 (4)
DPF221RGF15ST	1	13.00 (330.2)	7.50 (190.5)	4.75 (120.7)	8 (4)
DPF222RGF15ST	1	13.00 (330.2)	7.50 (190.5)	4.75 (120.7)	8 (4)
DPF221RGF15WTST	1	13.00 (330.2)	7.50 (190.5)	4.75 (120.7)	8 (4)
DPF221RGF20WTST	1	13.00 (330.2)	7.50 (190.5)	4.75 (120.7)	8 (4)
DPF222RGF15WTST	1	13.00 (330.2)	7.50 (190.5)	4.75 (120.7)	8 (4)
DPF222RGF20WTST	1	13.00 (330.2)	7.50 (190.5)	4.75 (120.7)	8 (4)
DPU222RGF15WTST	1	13.00 (330.2)	7.50 (190.5)	4.75 (120.7)	8 (4)
DPU222RGF20WTST	1	13.00 (330.2)	7.50 (190.5)	4.75 (120.7)	8 (4)
DPU362R	1	8.60 (218.4)	5.30 (134.6)	3.74 (94.9)	4 (2)
<b>Non-Metallic/Polycarbonate Enclosure</b>					
ACD221RNM-A2	10	8.63 (219.0)	6.26 (159.0)	4.33 (109.9)	15 (7)
ACD222RNM-A2	10	8.63 (219.0)	6.26 (159.0)	4.33 (109.9)	15 (7)
ACD222URNM-A2	10	8.63 (219.0)	6.26 (159.0)	4.33 (109.9)	15 (7)
B60NARNM-A2	10	8.63 (219.0)	6.26 (159.0)	4.33 (109.9)	18 (8)

**Note**

<sup>Ⓢ</sup> Eaton Quick Pro designated item.

# 6.1

## Air Conditioning Disconnects

Fused, Unfused and Molded Case Switch

Approximate Dimensions in Inches (mm)

DPF221R, DPF222R, DPU222R, DPU222R12W and DPU222R34W

6

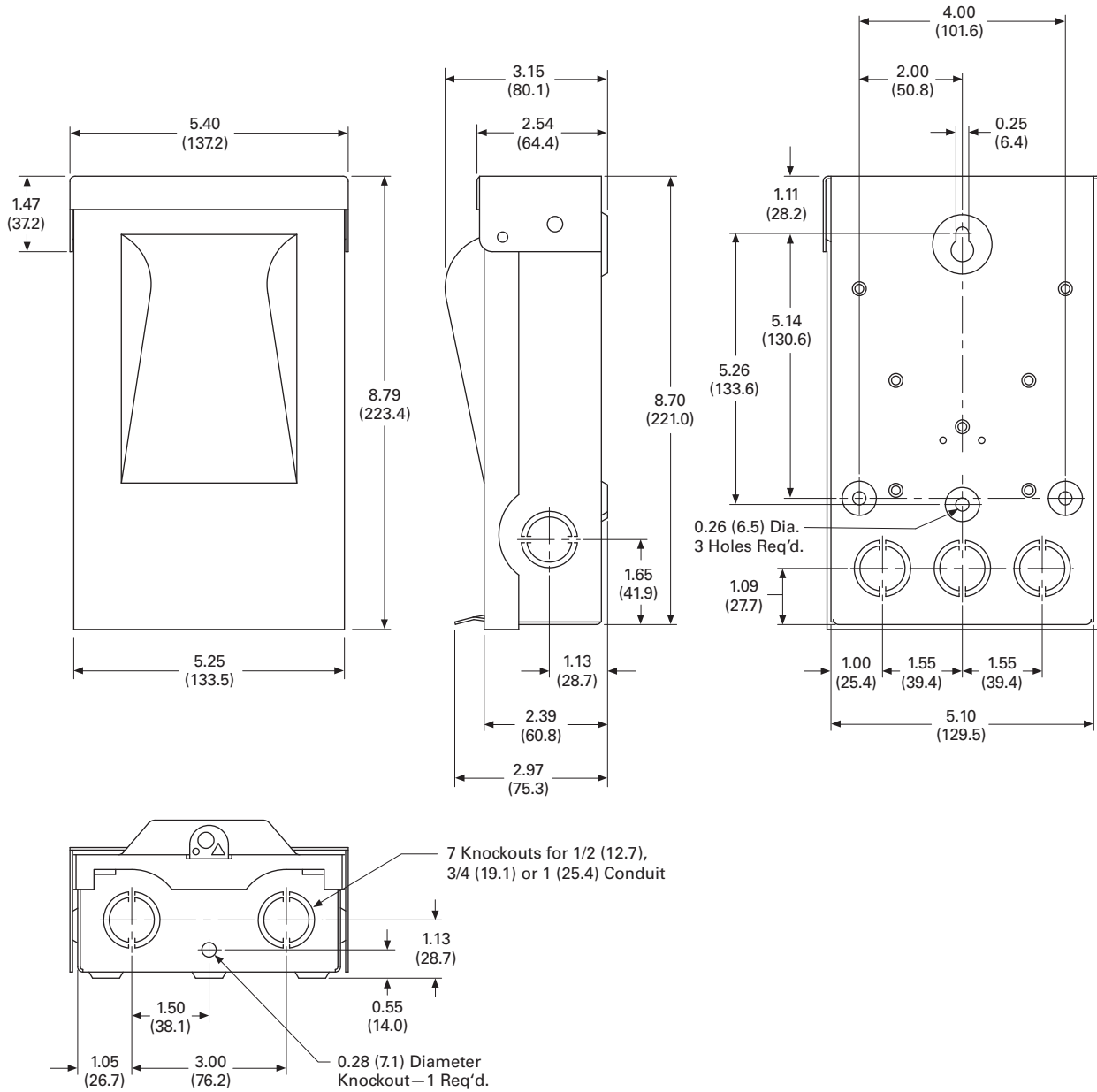

Approximate Dimensions in Inches (mm)

### ACD221RNM-A2, ACD222RNM-A2, ACD222URNM-A2 and B60NARNM-A2

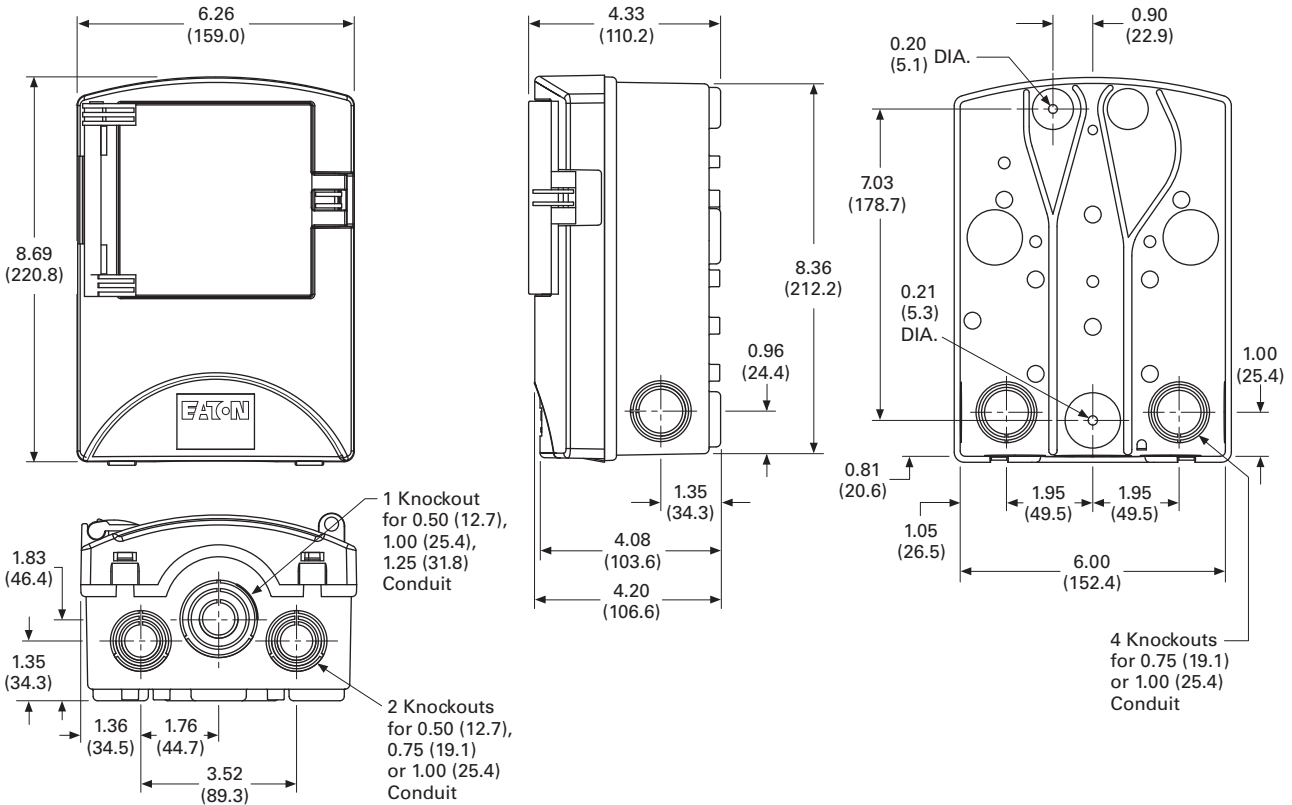

### DPB222R and DPU362A

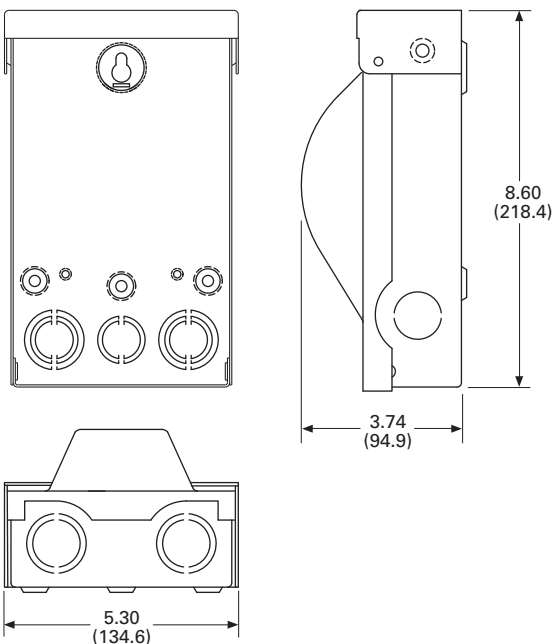

# 6.1

## Air Conditioning Disconnects

Fused, Unfused and Molded Case Switch

Approximate Dimensions in Inches (mm)

DPU222RGF20, DPF221RGF20, DPF222RGF20, DPU222RGF15, DPF221RGF15, DPF222RGF15, DPF221RGF15WTST, DPF221RGF20WTST, DPF222RGF15WTST, DPF222RGF20WTST, DPU222RGF15WTST and DPU222RGF20WTST

6

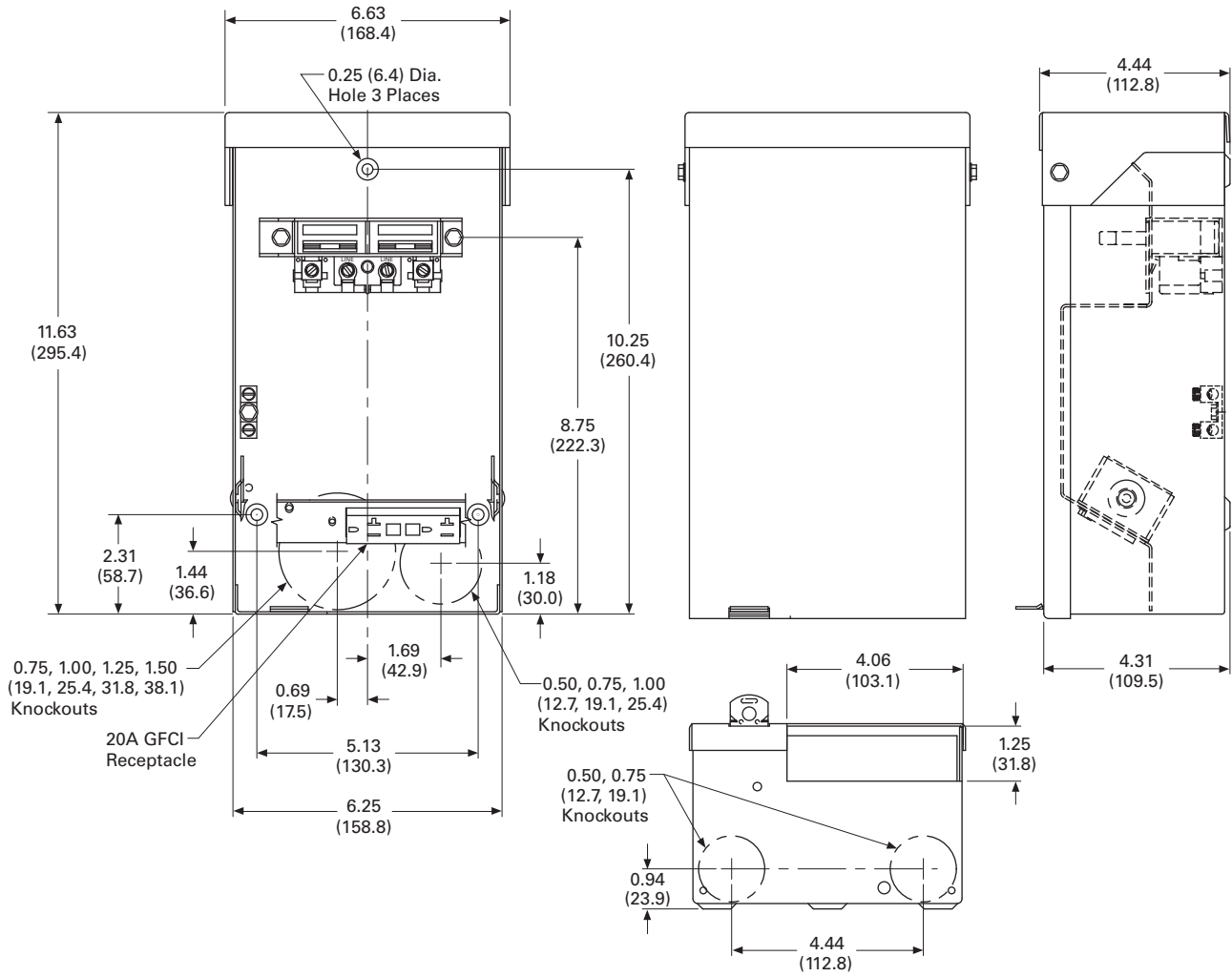

Eaton Terms & Conditions



## Terms & Conditions



### Contents

<i>Description</i>	<i>Page</i>
Terms and Conditions of Sale . . . . .	V1-A1-1
Terms of Payment . . . . .	V1-A1-2
Freight . . . . .	V1-A1-3
Warranty . . . . .	V1-A1-3

### Selling Policy (Supersedes Selling Policy 25-000, dated November 1, 2008)

#### Terms and Conditions of Sale

The Terms and Conditions of Sale set forth herein, and any supplements which may be attached hereto, constitute the full and final expression of the contract for the sale of products or services (hereinafter referred to as Product(s) or Services by Eaton Corporation (hereinafter referred to as Seller) to the Buyer, and supersedes all prior quotations, purchase orders, correspondence or communications whether written or oral between the Seller and the Buyer. Notwithstanding any contrary language in the Buyer's purchase order, correspondence or other form of acknowledgment, Buyer shall be bound by these Terms and Conditions of Sale when it sends a purchase order or otherwise indicates acceptance of this contract, or when it accepts delivery from Seller of the Products or Services.

THE CONTRACT FOR SALE OF THE PRODUCTS OR SERVICES IS EXPRESSLY LIMITED TO THE TERMS AND CONDITIONS OF SALE STATED HEREIN. ANY ADDITIONAL OR DIFFERENT TERMS PROPOSED BY BUYER ARE REJECTED UNLESS EXPRESSLY AGREED TO IN WRITING BY SELLER. No contract shall exist except as herein provided.

#### **Complete Agreement**

No amendment or modification hereto nor any statement, representation or warranty not contained herein shall be binding on the Seller unless made in writing by an authorized representative of the Seller. Prior dealings, usage of the trade or a course of performance shall not be relevant to determine the meaning of this contract even though the accepting or acquiescing party had knowledge of the nature of the performance and opportunity for objection.

#### **Quotations**

Written quotations are valid for 30 days from its date unless otherwise stated in the quotation or terminated sooner by notice.

Verbal quotations, unless accepted, expire the same day they are made.

A complete signed order must be received by Seller within 20 calendar days of notification of award, otherwise the price and shipment will be subject to re-negotiation.

#### **Termination and Cancellation**

##### **Products**

Any order may be terminated by the Buyer only by written notice and upon payment of reasonable termination charges, including all progress billings and all incurred direct manufacturing costs.

##### **Services**

Any order may be terminated by the Buyer only by written notice and upon payment of reasonable termination charges including all costs plus profit.

Seller shall have the right to cancel any order at any time by written notice if Buyer breaches any of the terms hereof, becomes the subject of any proceeding under state or federal law for the relief of debtors, or otherwise becomes insolvent or bankrupt, generally does not pay its debts as they become due or makes an assignment for the benefit of creditors.

# Appendix 1—General Terms and Conditions of Sale

Effective Date: November 1, 2017

## **Prices**

All prices are subject to change without notice. In the event of a price change, the effective date of the change will be the date of the new price or discount sheet, letter or telegram. All quotations made or orders accepted after the effective date will be on the new basis. For existing orders, the price of the unshipped portion of an order will be the price in effect at time of shipment.

## **Price Policy—Products and Services**

When prices are quoted as firm for quoted shipment, they are firm provided the following conditions are met:

1. The order is released with complete engineering details.
2. Shipment of Products are made, and Services purchased are provided within the quoted lead time.
3. When drawings for approval are required for any Products, the drawings applicable to those Products must be returned within 30\* calendar days from the date of the original mailing of the drawings by Seller. The return drawings must be released for manufacture and shipment and must be marked "APPROVED" or "APPROVED AS NOTED." Drawing re-submittals which are required for any other reason than to correct Seller errors will not extend the 30-day period.

\* 60 days for orders through contractors to allow time for their review and approval before and after transmitting them to their customers.

If the Buyer initiates or in any way causes delays in shipment, provision of Services or return of approval drawings beyond the periods stated above, the price of the Products or Services will be increased 1% per month or fraction thereof up to a maximum of 18 months from the date of the Buyer's order. For delays resulting in shipment or provision of Services beyond 18 months from the date of the Buyer's order, the price must be renegotiated.

## **Price Policy—BLS**

Refer to Price Policy 25-050.

## **Minimum Billing**

Orders less than \$1,000 will be assessed a shipping and handling charge of 5% of the price of the order, with a minimum charge of \$25.00 unless noted differently on Product discount sheets.

## **Taxes**

The price does not include any taxes. Buyer shall be responsible for the payment of all taxes applicable to, or arising from the transaction, the Products, its sale, value, or use, or any Services performed in connection therewith regardless of the person or entity actually taxed.

## **Terms of Payment**

### **Products**

Acceptance of all orders is subject to the Buyer meeting Seller's credit requirements. Terms of payment are subject to change for failure to meet such requirements. Seller reserves the right at any time to demand full or partial payment before proceeding with a contract of sale as a result of changes in the financial condition of the Buyer. Terms of Payment are either Net 30 days from the date of invoice of each shipment or carry a cash discount based on Product type. Specific payment terms for Products are outlined in the applicable Product discount schedules.

### **Services**

Terms of payment are net within 30 days from date of invoice for orders amounting to less than \$50,000.00.

Terms of payment for orders exceeding \$50,000.00 shall be made according to the following:

1. Twenty percent (20%) of order value with the purchase order payable 30 days from date of invoice.
2. Eighty percent (80%) of order value in equal monthly payments over the performance period payable 30 days from date of invoice.

Except for work performed (i) under a firm fixed price basis or (ii) pursuant to terms of a previously priced existing contract between Seller and Buyer, invoices for work performed by Seller shall have added and noted on each invoice a charge of 3% (over and above the price of the work) which is related to Seller compliance with present and proposed environmental, health, and safety regulations associated with prescribed requirements covering hazardous materials management and employee training, communications, personal protective equipment, documentation and record keeping associated therewith.

### **Adequate Assurances**

If, in the judgment of Seller, the financial condition of the Buyer, at any time during the period of the contract, does not justify the terms of payment specified, Seller may require full or partial payment in advance.

### **Delayed Payment**

If payments are not made in accordance with these terms, a service charge will, without prejudice to the right of Seller to immediate payment, be added in an amount equal to the lower of 1.5% per month or fraction thereof or the highest legal rate on the unpaid balance.



## Freight

Freight policy will be listed on the Product discount sheets, or at option of Seller one of the following freight terms will be quoted.

### **F.O.B.—P/S—Frt./Ppd. and Invoiced**

Products are sold F.O.B. point of shipment freight prepaid and invoiced to the Buyer.

### **F.O.B.—P/S—Frt./Ppd. and Allowed**

Products sold are delivered F.O.B. point of shipment, freight prepaid and included in the price.

### **F.O.B. Destination—Frt./Ppd. and Allowed**

At Buyer's option, Seller will deliver the Products F.O.B. destination freight prepaid and 2% will be added to the net price.

The term "freight prepaid" means that freight charges will be prepaid to the accessible common carrier delivery point nearest the destination for shipments within the United States and Puerto Rico unless noted differently on the Product discount sheets. For any other destination, contact Seller's representative.

### **Shipment and Routing**

Seller shall select the point of origin of shipment, the method of transportation, the type of carrier equipment and the routing of the shipment.

If the Buyer specifies a special method of transportation, type of carrier equipment, routing, or delivery requirement, Buyer shall pay all special freight and handling charges.

When freight is included in the price, no allowance will be made in lieu of transportation if the Buyer accepts shipment at factory, warehouse, or freight station or otherwise supplies its own transportation.

## Risk of Loss

Risk of loss or damage to the Products shall pass to Buyer at the F.O.B. point.

### **Concealed Damage**

Except in the event of F.O.B. destination shipments, Seller will not participate in any settlement of claims for concealed damage.

When shipment has been made on an F.O.B. destination basis, the Buyer must unpack immediately and, if damage is discovered, must:

1. Not move the Products from the point of examination.
2. Retain shipping container and packing material.
3. Notify the carrier in writing of any apparent damage.
4. Notify Seller representative within 72 hours of delivery.
5. Send Seller a copy of the carrier's inspection report.

### **Witness Tests/Customer Inspection**

Standard factory tests may be witnessed by the Buyer at Seller's factory for an additional charge calculated at the rate of \$2,500 per day (not to exceed eight (8) hours) per Product type. Buyer may final inspect Products at the Seller's factory for \$500 per day per Product type.

Witness tests will add one (1) week to the scheduled shipping date. Seller will notify Buyer fourteen (14) calendar days prior to scheduled witness testing or inspection. In the event Buyer is unable to attend, the Parties shall mutually agree on a rescheduled date. However, Seller reserves the right to deem the witness tests waived with the right to ship and invoice Products.

## Held Orders

For any order held, delayed or rescheduled at the request of the Buyer, Seller may, at its sole option (1) require payment to be based on any reasonable basis, including but not limited to the contract price, and any additional expenses, or cost resulting from such a delay; (2) store Products at the sole cost and risk of loss of the Buyer; and/ or (3) charge to the Buyer those prices under the applicable price policy. Payment for such price, expenses and costs, in any such event, shall be due by Buyer within thirty (30) days from date of Seller's invoice. Any order so held delayed or rescheduled beyond six (6) months will be treated as a Buyer termination.

### **Drawing Approval**

Seller will design the Products in line with, in Seller's judgment, good commercial practice. If at drawing approval Buyer makes changes outside of the design as covered in their specifications, Seller will then be paid reasonable charges and allowed a commensurate delay in shipping date based on the changes made.

### **Drawing Re-Submittal**

When Seller agrees to do so in its quotation, Seller shall provide Buyer with the first set of factory customer approval drawing(s) at Seller's expense. The customer approval drawing(s) will be delivered at the quoted delivery date. If Buyer requests drawing changes or additions after the initial factory customer approval drawing(s) have been submitted by Seller, the Seller, at its option, may assess Buyer drawing charges. Factory customer approval drawing changes required due to misinterpretation by Seller will be at Seller's expense. Approval drawings generated by Bid Manager are excluded from this provision.

## Warranty

### **Warranty for Products**

Seller warrants that the Products manufactured by it will conform to Seller's applicable specifications and be free from failure due to defects in workmanship and material for one (1) year from the date of installation of the Product or eighteen (18) months from the date of shipment of the Product, whichever occurs first.

In the event any Product fails to comply with the foregoing warranty, Seller will, at its option, either (a) repair or replace the defective Product, or defective part or component thereof, F.O.B. Seller's facility freight prepaid, or (b) credit Buyer for the purchase price of the Product. All warranty claims shall be made in writing.

Seller requires all non-conforming Products be returned at Seller's expense for evaluation unless specifically stated otherwise in writing by Seller.

This warranty does not cover failure or damage due to storage, installation, operation or maintenance not in conformance with Seller's recommendations and industry standard practice or due to accident, misuse, abuse or negligence. This warranty does not cover reimbursement for labor, gaining access, removal, installation, temporary power or any other expenses, which may be incurred in connection with repair or replacement.

This warranty does not apply to equipment not manufactured by Seller. Seller limits itself to extending the same warranty it receives from the supplier.

# Appendix 1—General Terms and Conditions of Sale

Effective Date: November 1, 2017

## **Extended Warranty for Products**

If requested by the Buyer and specifically accepted in writing by Seller, the foregoing standard warranty for Products will be extended from the date of shipment for the period and price indicated below:

- 24 months—2% of Contract Price
- 30 months—3% of Contract Price
- 36 months—4% of Contract Price

## **Special Warranty (In and Out) for Products**

If requested by the Buyer and specifically accepted in writing by Seller, Seller will, during the warranty period for Products, at an additional cost of 2% of the contract price, be responsible for the direct cost of:

1. Removing the Product from the installed location.
2. Transportation to the repair facility and return to the site.
3. Reinstallation on site.

The total liability of Seller for this Special Warranty for Products is limited to 50% of the contract price of the particular Product being repaired and excludes expenses for removing adjacent apparatus, walls, piping, structures, temporary service, etc.

## **Warranty for Services**

Seller warrants that the Services performed by it hereunder will be performed in accordance with generally accepted professional standards.

The Services, which do not so conform, shall be corrected by Seller upon notification in writing by the Buyer within one (1) year after completion of the Services.

Unless otherwise agreed to in writing by Seller, Seller assumes no responsibility with respect to the suitability of the Buyer's, or its customer's, equipment or with respect to any latent defects in equipment not supplied by Seller. This warranty does not cover damage to Buyer's, or its customer's, equipment, components or parts resulting in whole or in part from improper maintenance or operation or from their deteriorated condition. Buyer will, at its cost, provide Seller with unobstructed access to the defective Services, as well as adequate free working space in the immediate vicinity of the defective Services and such facilities and systems, including, without limitation, docks, cranes and utility disconnects and connects, as may be necessary in order that Seller may perform its warranty obligations. The conducting of any tests shall be mutually agreed upon and Seller shall be notified of, and may be present at, all tests that may be made.

## **Warranty for Power Systems Studies**

Seller warrants that any power systems studies performed by it will conform to generally accepted professional standards. Any portion of the study, which does not so conform, shall be corrected by Seller upon notification in writing by the Buyer within six (6) months after completion of the study. All warranty work shall be performed in a single shift straight time basis Monday through Friday. In the event that the study requires correction of warranty items on an overtime schedule, the premium portion of such overtime shall be for the Buyer's account.

## **Limitation on Warranties for Products, Services and Power Systems Studies**

THE FOREGOING WARRANTIES ARE EXCLUSIVE EXCEPT FOR WARRANTY OF TITLE. SELLER DISCLAIMS ALL OTHER WARRANTIES INCLUDING ANY IMPLIED WARRANTIES OF MERCHANTABILITY AND FITNESS FOR A PARTICULAR PURPOSE.

CORRECTION OF NON-CONFORMITIES IN THE MANNER AND FOR THE PERIOD OF TIME PROVIDED ABOVE SHALL CONSTITUTE SELLER'S SOLE LIABILITY AND BUYER'S EXCLUSIVE REMEDY FOR FAILURE OF SELLER TO MEET ITS WARRANTY OBLIGATIONS, WHETHER CLAIMS OF THE BUYER ARE BASED IN CONTRACT, IN TORT (INCLUDING NEGLIGENCE OR STRICT LIABILITY), OR OTHERWISE.

## **Asbestos**

Federal Law requires that building or facility owners identify the presence, location and quantity of asbestos containing material (hereinafter "ACM") at work sites. Seller is not licensed to abate ACM. Accordingly, for any contract which includes the provision of Services, prior to (i) commencement of work at any site under a specific Purchase Order, (ii) a change in the work scope of any Purchase Order, the Buyer will certify that the work area associated with the Seller's scope of work includes the handling of Class II ACM, including but not limited to generator wedges and high temperature gaskets which include asbestos materials. The Buyer shall, at its expense, conduct abatement should the removal, handling, modification or reinstallation, or some or all of them, of said Class II ACM be likely to generate airborne asbestos fibers; and should such abatement affect the cost of or time of performance of the work, then Seller shall be entitled to an equitable adjustment in the schedule, price and other pertinent affected provisions of the contract.

## **Compliance with Nuclear Regulation**

Seller's Products are sold as commercial grade Products not intended for application in facilities or activities licensed by the United States Nuclear Regulatory Commission for atomic purposes. Further certification will be required for use of the Products in any safety-related application in any nuclear facility licensed by the U.S. Nuclear Regulatory Commission.

## **Returning Products**

Authorization and shipping instructions for the return of any Products must be obtained from Seller before returning the Products.

When return is occasioned due to Seller error, full credit including all transportation charges will be allowed.

## **Product Notices**

Buyer shall provide the user (including its employees) of the Products with all Seller supplied Product notices, warnings, instructions, recommendations, and similar materials.

## **Force Majeure**

Seller shall not be liable for failure to perform or delay in performance due to fire, flood, strike or other labor difficulty, act of God, act of any governmental authority or of the Buyer, riot, embargo, fuel or energy shortage, car shortage, wrecks or delays in transportation, or due to any other cause beyond Seller's reasonable control. In the event of delay in performance due to any such cause, the date of delivery or time for completion will be extended by a period of time reasonably necessary to overcome the effect of such delay.

## **Liquidated Damages**

Contracts which include liquidated damage clauses for failure to meet shipping or job completion promises are not acceptable or binding on Seller, unless such clauses are specifically accepted in writing by an authorized representative of the Seller at its headquarters office.

## **Patent Infringement**

Seller will defend or, at its option, settle any suit or proceeding brought against Buyer, or Buyer's customers, to the extent it is based upon a claim that any Product or part thereof, manufactured by Seller or its subsidiaries and furnished hereunder, infringes any United States patent, other than a claim of infringement based upon use of a Product or part thereof in a process, provided Seller is notified in reasonable time and given authority, information and assistance (at Seller's expense) for the defense of same. Seller shall pay all legal and court costs and expenses and court-assessed damages awarded therein against Buyer resulting from or incident to such suit or proceeding. In addition to the foregoing, if at any time Seller determines there is a substantial question of infringement of any United States patent, and the use of such Product is or may be enjoined, Seller may, at its option and expense: either (a) procure for Buyer the right to continue using and selling the Product; (b) replace the Product with non-infringing apparatus; (c) modify the Product so it becomes non-infringing; or (d) as a last resort, remove the Product and refund the purchase price, equitably adjusted for use and obsolescence. In no case does Seller agree to pay any recovery based upon its Buyer's savings or profit through use of Seller's Products whether the use be special or ordinary. The foregoing states the entire liability of Seller for patent infringement.

The preceding paragraph does not apply to any claim of infringement based upon: (a) any modification made to a Product other than by Seller; (b) any design and/or specifications of Buyer to which a Product was manufactured; or (c) the use or combination of Product with other products where the Product does not itself infringe. As to the above-identified claim situations where the preceding paragraph does not apply, Buyer shall defend and hold Seller harmless in the same manner and to the extent as Seller's obligations described in the preceding paragraph. Buyer shall be responsible for obtaining (at Buyer's expense) all license rights required for Seller to be able to use software products in the possession of Buyer where such use is required in order to perform any Service for Buyer.

With respect to a Product or part thereof not manufactured by Seller or its subsidiaries, Seller will attempt to obtain for Buyer, from the supplier(s), the patent indemnification protection normally provided by the supplier(s) to customers.

## **Compliance with OSHA**

Seller offers no warranty and makes no representation that its Products comply with the provisions or standards of the Occupational Safety and Health Act of 1970, or any regulation issued thereunder. In no event shall Seller be liable for any loss, damage, fines, penalty or expenses arising under said Act.

## **Limitation of Liability**

THE REMEDIES OF THE BUYER SET FORTH IN THIS CONTRACT ARE EXCLUSIVE AND ARE ITS SOLE REMEDIES FOR ANY FAILURE OF SELLER TO COMPLY WITH ITS OBLIGATIONS HEREUNDER.

NOTWITHSTANDING ANY PROVISION IN THIS CONTRACT TO THE CONTRARY, IN NO EVENT SHALL SELLER BE LIABLE IN CONTRACT, IN TORT (INCLUDING NEGLIGENCE OR STRICT LIABILITY) OR OTHERWISE FOR DAMAGE TO PROPERTY OR EQUIPMENT OTHER THAN PRODUCTS SOLD HEREUNDER, LOSS OF PROFITS OR REVENUE, LOSS OF USE OF PRODUCTS, COST OF CAPITAL, CLAIMS OF CUSTOMERS OF THE BUYER OR ANY SPECIAL, INDIRECT, INCIDENTAL OR CONSEQUENTIAL DAMAGES WHATSOEVER, REGARDLESS OF WHETHER SUCH POTENTIAL DAMAGES ARE FORESEEABLE OR IF SELLER HAS BEEN ADVISED OF THE POSSIBILITY OF SUCH DAMAGES.

THE TOTAL CUMULATIVE LIABILITY OF SELLER ARISING FROM OR RELATED TO THIS CONTRACT WHETHER THE CLAIMS ARE BASED IN CONTRACT, IN TORT (INCLUDING NEGLIGENCE OR STRICT LIABILITY) OR OTHERWISE, SHALL NOT EXCEED THE PRICE OF THE PRODUCT OR SERVICES ON WHICH SUCH LIABILITY IS BASED.

**A**

ACD..... V1-T6-4, V1-T6-6  
 ACD2..... V1-T6-4, V1-T6-6  
 ARP..... V1-T4-50, V1-T5-8  
 ARPO..... V1-T4-31, V1-T4-32, V1-T4-58

**B**

BD..... V1-T1-81  
 BH..... V1-T1-85  
 BHG..... V1-T1-85  
 BHL..... V1-T1-85  
 BHT..... V1-T1-85  
 BIN..... V1-T1-24  
 BINA..... V1-T1-21, V1-T1-24, V1-T1-63, V1-T1-92  
 BJ..... V1-T1-84, V1-T1-86  
 BJH..... V1-T1-84, V1-T1-86  
 BJL..... V1-T1-86  
 BQ..... V1-T1-81  
 BQC..... V1-T1-83  
 BR..... V1-T2-10  
 BRB..... V1-T1-69  
 BRC..... V1-T1-57, V1-T1-69  
 BRD..... V1-T1-69, V1-T1-82, V1-T1-85  
 BRE..... V1-T1-86  
 BRF..... V1-T1-63  
 BRG..... V1-T1-59, V1-T1-68, V1-T1-69, V1-T1-93  
 BRH..... V1-T1-52, V1-T1-78, V1-T1-79, V1-T1-86,  
 V1-T4-88, V1-T4-117  
 BRHH..... V1-T1-78, V1-T4-88, V1-T4-117  
 BRL..... V1-T1-52, V1-T1-57, V1-T1-63, V1-T1-69,  
 V1-T1-85  
 BRL2..... V1-T1-79  
 BRM..... V1-T1-63, V1-T1-86  
 BRP..... V1-T1-86  
 BRQ..... V1-T1-85  
 BRR..... V1-T1-63  
 BRS..... V1-T1-14, V1-T1-52, V1-T1-63, V1-T1-84,  
 V1-T4-136  
 BRSF..... V1-T4-136  
 BRSUR..... V1-T1-14, V1-T2-9  
 BRW..... V1-T1-84  
 BRX..... V1-T1-78  
 BR1..... V1-T1-46–V1-T1-49, V1-T1-51, V1-T1-53,  
 V1-T1-59, V1-T1-60, V1-T1-78, V1-T1-82  
 BR2..... V1-T1-46–V1-T1-49, V1-T1-51–V1-T1-52,  
 V1-T1-57, V1-T1-59, V1-T1-60, V1-T1-78,  
 V1-T1-82, V1-T1-84, V1-T4-88, V1-T4-117,  
 V1-T5-22  
 BR23..... V1-T2-7  
 BR25..... V1-T2-7  
 BR3..... V1-T1-46, V1-T1-49, V1-T1-51–V1-T1-52,  
 V1-T1-57, V1-T1-59, V1-T1-79, V1-T1-82  
 BR4..... V1-T1-46–V1-T1-49, V1-T1-51–V1-T1-53,  
 V1-T1-57, V1-T1-82  
 BR42..... V1-T1-47  
 BR5..... V1-T1-58  
 BR6..... V1-T1-48  
 BR8..... V1-T1-46, V1-T1-48, V1-T1-49, V1-T1-51,  
 V1-T1-52

BSC..... V1-T1-21  
 BSS..... V1-T1-21, V1-T1-63  
 BW..... V1-T1-63, V1-T4-38  
 BWFP..... V1-T1-63  
 B424..... V1-T1-47  
 B60N..... V1-T6-4, V1-T6-6

**C**

CC..... V1-T1-38, V1-T1-64, V1-T1-85, V1-T1-95  
 CCH..... V1-T1-95  
 CCL..... V1-T1-38, V1-T1-86  
 CCV..... V1-T1-95, V1-T4-118  
 CCVH..... V1-T1-95, V1-T4-88, V1-T4-118, V1-T4-130  
 CCV2..... V1-T4-88, V1-T4-118, V1-T4-130  
 CC3..... V1-T1-95, V1-T4-130  
 CG..... V1-T4-49  
 CH..... V1-T1-90  
 CHB..... V1-T1-21, V1-T1-63, V1-T5-8  
 CHE..... V1-T1-15  
 CHEC..... V1-T2-9  
 CHEG..... V1-T3-5, V1-T3-9  
 CHF..... V1-T1-21, V1-T1-32, V1-T1-33  
 CHFL..... V1-T5-7  
 CHG..... V1-T1-24  
 CHH..... V1-T1-38  
 CHI..... V1-T5-8  
 CHL..... V1-T1-10, V1-T1-22, V1-T1-38, V1-T1-99,  
 V1-T5-8  
 CHLD..... V1-T5-8  
 CHLDF..... V1-T5-8, V1-T5-9  
 CHM..... V1-T1-21, V1-T1-38, V1-T4-39, V1-T5-12,  
 V1-T5-17  
 CHMM..... V1-T4-39  
 CHM1..... V1-T5-12, V1-T5-17  
 CHM4..... V1-T5-17  
 CHM5..... V1-T5-12  
 CHM7..... V1-T5-12  
 CHN..... V1-T1-21, V1-T1-24, V1-T5-9  
 CHOU..... V1-T5-9  
 CHP..... V1-T1-23, V1-T1-36–V1-T1-38  
 CHPA..... V1-T5-7, V1-T5-23  
 CHPE..... V1-T5-7  
 CHPO..... V1-T5-8, V1-T5-9  
 CHQ..... V1-T1-97, V1-T2-10  
 CHR..... V1-T1-21, V1-T5-12, V1-T5-17  
 CHR1..... V1-T5-12, V1-T5-17  
 CHR3..... V1-T5-12  
 CHR7..... V1-T5-12  
 CHS..... V1-T1-14, V1-T1-15, V1-T1-21  
 CHSA..... V1-T2-10  
 CHSPC..... V1-T2-6  
 CHSPF..... V1-T2-6  
 CHSPT..... V1-T2-4–V1-T2-6  
 CHSP3..... V1-T2-6  
 CHSUR..... V1-T2-9  
 CHT..... V1-T1-35  
 CHTE..... V1-T5-7

## Appendix 2—Catalog Parent Number Index

CHU..... V1-T4-56, V1-T4-57, V1-T5-11, V1-T5-17  
 CHUD ..... V1-T5-9  
 CHU1..... V1-T5-11, V1-T5-17  
 CHU2..... V1-T4-56, V1-T5-11  
 CHU3..... V1-T5-11  
 CHU4..... V1-T5-11, V1-T5-17  
 CHU5..... V1-T5-11  
 CHU6..... V1-T5-11  
 CHU7..... V1-T5-11  
 CH1..... V1-T1-6, V1-T1-9, V1-T1-12, V1-T1-22,  
 V1-T1-32–V1-T1-35, V1-T1-37, V1-T1-38,  
 V1-T3-8, V1-T3-9, V1-T4-56  
 CH2..... V1-T1-6–V1-T1-9, V1-T1-10, V1-T1-12, V1-T1-16,  
 V1-T1-17, V1-T1-22, V1-T1-32–V1-T1-35,  
 V1-T1-37, V1-T4-50, V1-T4-56, V1-T4-57  
 CH2L..... V1-T1-8  
 CH23..... V1-T2-7  
 CH25..... V1-T2-7  
 CH3..... V1-T1-6, V1-T1-7, V1-T1-9–V1-T1-13, V1-T1-16,  
 V1-T1-17, V1-T1-22, V1-T1-23,  
 V1-T1-32–V1-T1-35, V1-T3-5  
 CH4..... V1-T1-6–V1-T1-13, V1-T1-16, V1-T1-17,  
 V1-T1-22, V1-T3-8, V1-T3-9  
 CH4L..... V1-T1-8  
 CH5..... V1-T1-13, V1-T4-58  
 CH6..... V1-T1-12, V1-T1-13, V1-T1-16, V1-T1-22,  
 V1-T3-8, V1-T3-9  
 CH7..... V1-T1-6, V1-T1-9–V1-T1-12, V1-T1-23  
 CH8..... V1-T1-6–V1-T1-10, V1-T1-16, V1-T1-17,  
 V1-T1-22, V1-T1-25, V1-T3-8, V1-T3-9  
 CH8L..... V1-T1-8  
 CH9..... V1-T1-24, V1-T1-38, V1-T1-63  
 CL ..... V1-T2-10  
 CLRP..... V1-T1-98  
 CL1 ..... V1-T1-98  
 CL2 ..... V1-T1-98  
 CMB ..... V1-T4-39, V1-T4-40, V1-T4-59  
 CMBB ..... V1-T4-39  
 CMBE ..... V1-T4-42, V1-T4-43, V1-T4-54, V1-T4-59  
 CMBX ..... V1-T4-40  
 CSH..... V1-T1-10, V1-T1-22  
 CSH2..... V1-T1-10, V1-T4-38  
 CSR..... V1-T1-10, V1-T1-21, V1-T1-22, V1-T1-52,  
 V1-T4-38, V1-T5-22  
 CSR2..... V1-T1-10, V1-T4-38  
 CTA ..... V1-T4-132  
 CVH..... V1-T4-130  
 CVH2..... V1-T4-88, V1-T4-120  
 CVS ..... V1-T4-130  
 CVS2..... V1-T4-88, V1-T4-120  
 CV2 ..... V1-T4-88, V1-T4-120, V1-T4-130  
 CV3 ..... V1-T4-130

### D

DPB..... V1-T6-4, V1-T6-6  
 DPB2..... V1-T6-4, V1-T6-6  
 DPF..... V1-T6-4–V1-T6-6  
 DPF2..... V1-T6-4–V1-T6-6  
 DPU..... V1-T6-4–V1-T6-6

DPU2 ..... V1-T6-4–V1-T6-5  
 DS ..... V1-T1-24, V1-T1-68, V1-T5-7  
 DS1 ..... V1-T4-58  
 DS2 ..... V1-T4-58  
 DS3 ..... V1-T4-58  
 DS9 ..... V1-T4-58

### E

ECC ..... V1-T1-95  
 ECCV ..... V1-T1-95  
 EDL ..... V1-T4-33  
 EGS ..... V1-T3-9  
 EHD ..... V1-T4-130  
 EPBD ..... V1-T4-33  
 EPBQ ..... V1-T4-33  
 EPBS ..... V1-T4-33  
 EPBT ..... V1-T4-33  
 ESL ..... V1-T4-33

### G

GB ..... V1-T1-24, V1-T1-68, V1-T1-93  
 GBK ..... V1-T5-9  
 GFC ..... V1-T1-80  
 GFE ..... V1-T1-80  
 GHC..... V1-T5-75  
 GTAP ..... V1-T1-59

### H

HL ..... V1-T1-85  
 HPB ..... V1-T4-50  
 HPC ..... V1-T4-49  
 HPP ..... V1-T4-50  
 HP2 ..... V1-T4-50  
 HP4 ..... V1-T4-49, V1-T4-50  
 HP8 ..... V1-T4-49

### I

IG12..... V1-T2-8  
 IG52..... V1-T2-8  
 IG53..... V1-T2-8  
 IMM..... V1-T4-58

### J

JT..... V1-T5-75

### L

LC ..... V1-T1-21, V1-T1-63

### M

MBB..... V1-T4-39  
 MBE..... V1-T4-42, V1-T4-59  
 MBED ..... V1-T4-45  
 MBER ..... V1-T4-43  
 MBE1..... V1-T4-42, V1-T4-43  
 MBE2..... V1-T4-42, V1-T4-43

MBE3 ..... V1-**T4**-43  
 MBE4 ..... V1-**T4**-43  
 MBE8 ..... V1-**T4**-43  
 MBH ..... V1-**T4**-58  
 MBP ..... V1-**T4**-39  
 MBT ..... V1-**T4**-40  
 MBX ..... V1-**T4**-39  
 MB1 ..... V1-**T4**-40  
 MB2 ..... V1-**T4**-59  
 MB20 ..... V1-**T4**-40  
 MB4 ..... V1-**T4**-40  
 MB5 ..... V1-**T4**-58  
 MB8 ..... V1-**T4**-40, V1-**T4**-59  
 MCB ..... V1-**T1**-38, V1-**T1**-85, V1-**T4**-38  
 MCBK ..... V1-**T4**-38  
 MHD ..... V1-**T5**-23  
 MHM ..... V1-**T5**-22  
 MHP ..... V1-**T5**-23  
 MHR ..... V1-**T5**-22  
 MM ..... V1-**T4**-136  
 MPL ..... V1-**T5**-75–V1-**T5**-77  
 MPLFH ..... V1-**T5**-77  
 MSEG ..... V1-**T2**-6, V1-**T4**-34  
 MSL ..... V1-**T4**-139  
 MST ..... V1-**T4**-139

**N**

NL ..... V1-**T1**-21, V1-**T1**-63

**Q**

QCF ..... V1-**T5**-75  
 QCGF ..... V1-**T5**-75

**R**

RH ..... V1-**T1**-68  
 RN ..... V1-**T1**-17  
 RV ..... V1-**T5**-75, V1-**T5**-77

**S**

SPC ..... V1-**T1**-21, V1-**T1**-63  
 SP1 ..... V1-**T2**-4  
 SR ..... V1-**T1**-39, V1-**T1**-86  
 SRL ..... V1-**T1**-21, V1-**T1**-63  
 ST ..... V1-**T1**-39  
 STL ..... V1-**T4**-24

**T**

TCD ..... V1-**T1**-21, V1-**T1**-63  
 TDL ..... V1-**T1**-21, V1-**T1**-63  
 TH ..... V1-**T1**-85  
 TT120 ..... V1-**T1**-20

**U**

UAHT ..... V1-**T4**-5  
 UAST ..... V1-**T4**-24  
 UAT ..... V1-**T4**-18

UATE ..... V1-**T4**-14  
 UATH ..... V1-**T4**-11, V1-**T4**-12  
 UATR ..... V1-**T4**-4–V1-**T4**-6  
 UATZ ..... V1-**T4**-6, V1-**T4**-19  
 UBEH ..... V1-**T4**-13  
 UBGH ..... V1-**T4**-14  
 UBH ..... V1-**T4**-18, V1-**T4**-19  
 UBHR ..... V1-**T4**-5, V1-**T4**-6, V1-**T4**-13  
 UBHT ..... V1-**T4**-5  
 UBTE ..... V1-**T4**-13  
 UBTH ..... V1-**T4**-11, V1-**T4**-12  
 UBTR ..... V1-**T4**-6  
 UEHT ..... V1-**T4**-18  
 UETH ..... V1-**T4**-13  
 UE7 ..... V1-**T4**-14  
 UFHT ..... V1-**T4**-4–V1-**T4**-5  
 UFT ..... V1-**T4**-11, V1-**T4**-14  
 UFTE ..... V1-**T4**-13  
 UFTH ..... V1-**T4**-11  
 UFTR ..... V1-**T4**-5  
 UGE ..... V1-**T4**-14  
 UGHR ..... V1-**T4**-5  
 UGHT ..... V1-**T4**-4–V1-**T4**-6, V1-**T4**-25  
 UGRS ..... V1-**T4**-6  
 UGTE ..... V1-**T4**-13, V1-**T4**-14  
 UGTH ..... V1-**T4**-11  
 UGTR ..... V1-**T4**-4, V1-**T4**-5, V1-**T4**-25  
 UHI ..... V1-**T4**-18  
 UHIR ..... V1-**T4**-5  
 UHT ..... V1-**T4**-18, V1-**T4**-19  
 UHTR ..... V1-**T4**-4–V1-**T4**-6, V1-**T4**-25, V1-**T4**-29  
 UHTT ..... V1-**T4**-4, V1-**T4**-6, V1-**T4**-18  
 UH4 ..... V1-**T4**-11  
 UH5 ..... V1-**T4**-11  
 UH7 ..... V1-**T4**-11  
 UIH ..... V1-**T4**-14  
 ULTS ..... V1-**T4**-24  
 UNRR ..... V1-**T4**-7  
 URRS ..... V1-**T4**-7  
 URS ..... V1-**T4**-4, V1-**T4**-6, V1-**T4**-7  
 URT ..... V1-**T4**-20  
 URTR ..... V1-**T4**-7  
 USTH ..... V1-**T4**-24  
 USTL ..... V1-**T4**-24  
 USTS ..... V1-**T4**-24  
 UST6 ..... V1-**T4**-24  
 UTE ..... V1-**T4**-13, V1-**T4**-26  
 UTH ..... V1-**T4**-11, V1-**T4**-12, V1-**T4**-26  
 UTRS ..... V1-**T4**-4–V1-**T4**-7, V1-**T4**-25  
 UTTE ..... V1-**T4**-13, V1-**T4**-14  
 UTTH ..... V1-**T4**-11  
 UTZR ..... V1-**T4**-6  
 UT2 ..... V1-**T4**-18, V1-**T4**-19  
 UT3 ..... V1-**T4**-19  
 UT4 ..... V1-**T4**-18, V1-**T4**-19  
 UT5 ..... V1-**T4**-19  
 UT6 ..... V1-**T4**-19  
 U2R ..... V1-**T4**-20

## Appendix 2—Catalog Parent Number Index

U2V .....	V1-T4-20	1208 .....	V1-T2-8
U3R .....	V1-T4-18, V1-T4-20	1210 .....	V1-T2-8
U3V .....	V1-T4-20	1212 .....	V1-T1-91
U4R .....	V1-T4-18-V1-T4-20	1224 .....	V1-T1-50, V1-T1-91
U5R .....	V1-T4-18-V1-T4-20	1624 .....	V1-T1-91
U6R .....	V1-T4-18	17NE .....	V1-T1-92
U921 .....	V1-T4-5	1836 .....	V1-T1-91
		20NE .....	V1-T1-92
<b>W</b>		2024 .....	V1-T1-91
WCG .....	V1-T4-135	24IN .....	V1-T1-91
		24NE .....	V1-T1-92
		2424 .....	V1-T1-91
		2442 .....	V1-T1-91
		2460 .....	V1-T1-20
<b>Numerics</b>		3BR .....	V1-T1-54-V1-T1-56, V1-T1-63
1MCB .....	V1-T4-92, V1-T4-94	3B42 .....	V1-T1-54
1MFS .....	V1-T4-97, V1-T4-98	3HM .....	V1-T4-100
1MHC .....	V1-T4-92, V1-T4-94	3MC .....	V1-T4-100
1MM .....	V1-T4-109, V1-T4-135, V1-T4-136, V1-T4-138	3MCB .....	V1-T4-92, V1-T4-94, V1-T4-100
1MMA .....	V1-T4-135	3MF .....	V1-T4-100
1MMB .....	V1-T4-135-V1-T4-139	3MFS .....	V1-T4-97, V1-T4-98, V1-T4-100
1MMC .....	V1-T4-137	3MHC .....	V1-T4-92, V1-T4-94
1MMG .....	V1-T4-140	3MM .....	V1-T4-135, V1-T4-136
1MMJ .....	V1-T4-136	3MMB .....	V1-T4-135
1MMM .....	V1-T4-137	3MME .....	V1-T4-136, V1-T4-138
1MMP .....	V1-T4-135	3MM2 .....	V1-T4-108-V1-T4-111
1MMR .....	V1-T4-137	3MM3 .....	V1-T4-108-V1-T4-111
1MMS .....	V1-T4-136	3MM4 .....	V1-T4-108-V1-T4-111, V1-T4-131
1MMW .....	V1-T4-135, V1-T4-138	3MM5 .....	V1-T4-108-V1-T4-111, V1-T4-131
1MM3 .....	V1-T4-108, V1-T4-109	3MM6 .....	V1-T4-108-V1-T4-111
1MM4 .....	V1-T4-108, V1-T4-109	3MTB .....	V1-T4-91
1MM5 .....	V1-T4-108, V1-T4-109, V1-T4-135	3UGP .....	V1-T4-99
1MM6 .....	V1-T4-108, V1-T4-109	304 .....	V1-T1-91
1MPL .....	V1-T4-140	3424 .....	V1-T1-55
1MPS .....	V1-T4-78-V1-T4-140	35MM .....	V1-T4-124
1MP2 .....	V1-T4-78, V1-T4-79	35NE .....	V1-T1-92
1MP3 .....	V1-T4-78, V1-T4-79	35SS .....	V1-T4-126
1MP4 .....	V1-T4-78, V1-T4-79	37M .....	V1-T4-138
1MP5 .....	V1-T4-78, V1-T4-79	37MM .....	V1-T4-125, V1-T4-138, V1-T4-139
1MP6 .....	V1-T4-78, V1-T4-79	37SS .....	V1-T4-126
1MTB .....	V1-T4-91	4242 .....	V1-T1-50, V1-T1-91
1UGP .....	V1-T4-99	47 .....	V1-T4-137, V1-T4-139
1003 .....	V1-T4-5, V1-T4-6	48IN .....	V1-T1-91
1004 .....	V1-T4-5, V1-T4-6, V1-T4-12, V1-T4-18, V1-T4-19, V1-T4-24	49 .....	V1-T4-137, V1-T4-139
1005 .....	V1-T4-6	5250 .....	V1-T2-8
1006 .....	V1-T4-6, V1-T4-12, V1-T4-18, V1-T4-29	5262 .....	V1-T2-8
1007 .....	V1-T4-5, V1-T4-12, V1-T4-14, V1-T4-18, V1-T4-24	5362 .....	V1-T2-8
1008 .....	V1-T4-5, V1-T4-6, V1-T4-12, V1-T4-14, V1-T4-18, V1-T4-19, V1-T4-24, V1-T4-29	612I .....	V1-T1-91
1009 .....	V1-T4-5-V1-T4-7, V1-T4-12-V1-T4-14, V1-T4-18, V1-T4-19, V1-T4-29	7821 .....	V1-T4-12
1010 .....	V1-T4-11	7866 .....	V1-T4-5
		816I .....	V1-T1-91

## A

Access Panel	
Marina Power and Lighting Equipment/ RV Park Hook-Ups	
Accessories	V1-T5-77
Accessories	
Classified Circuit Breakers	
Loadcenters and Circuit Breakers	V1-T1-99
Manual Transfer Switches	
Flush Flange Kit	V1-T3-9
Power Inlet Box	V1-T3-9
Marina Power and Lighting Equipment/ RV Park Hook-Ups	
Access Panel	V1-T5-77
Breaker Plate	V1-T5-75
Bus Bar Assembly	V1-T5-76, V1-T5-77
Circuit Breakers	V1-T5-75
Cover Set	V1-T5-75
Digital Electronic Meters	V1-T5-76
Door Hasp	V1-T5-77
External Cover	V1-T5-76
Faceplate	V1-T5-75–V1-T5-77
Fire Extinguisher	V1-T5-77
Fluorescent Light Assembly	V1-T5-75
Fuse Holder	V1-T5-76
Hose and Cable Brackets	V1-T5-75
Isolation Plate	V1-T5-75
Lens	V1-T5-77
Life Ring	V1-T5-77
Light and Lens Assembly	V1-T5-75
Light Fuse	V1-T5-76, V1-T5-77
Light Holder	V1-T5-77
Main Door	V1-T5-75, V1-T5-77
Main Housing	V1-T5-75–V1-T5-77
Mounting Brackets	V1-T5-77
Mounting Feet	V1-T5-76
Phone, Cable, Internet Assemblies	V1-T5-76
Receptacles	V1-T5-75
Spring Closure	V1-T5-75
Strobe Light	V1-T5-77
Water Assemblies	V1-T5-76
Meter Breakers	
House Panel Accessories	V1-T4-50
Metering Products	
Group Metering Inline Current Transformer Cabinets Accessories, Group Metering	V1-T4-132
Meter Socket Accessories	V1-T4-31
Metering Stack Accessories, Group Metering	V1-T4-30, V1-T4-136, V1-T4-138
Mobile Home Panels	V1-T5-23
Direct Feed Kit	V1-T5-23
Padmount Adapter	V1-T5-23
Pedestal Extension	V1-T5-23
Surge Protection Devices and Lightning Arresters	
Flushmount Kit	V1-T2-6
Outdoor Communication Grounding Device	V1-T2-6
Quick Connect Design	V1-T2-6
Raintight Enclosure	V1-T2-6
Surge Protection for AC Power and Cable	V1-T2-6

## Accessories, continued

Temporary Power/RV Park	
Cable TV and Telephone Bracket	V1-T5-7
Fluorescent Light Kit	V1-T5-7
Pad-Mount Bracket	V1-T5-7
Pedestal Extension	V1-T5-7
Rainproof Conduit Hub	V1-T5-7
Renewal Parts	V1-T5-8
Type BR Loadcenters and Circuit Breakers	V1-T1-63
Alarm Contacts	V1-T1-86
Auxiliary Contact	V1-T1-86
Field Installation and Parts	V1-T1-63
Filler Plates	V1-T1-63
Ground Bar Kits	V1-T1-68, V1-T1-93
Handle Lockoffs	V1-T1-85
Handle Ties	V1-T1-85
Hold-Down Kits	V1-T1-86
Main and Sub-Feed Lug Blocks	V1-T1-63
Main Breaker Lug Kits	V1-T1-86
Main Lugs	V1-T1-63
Mechanical Interlock Covers	V1-T1-66
Mechanical Interlocks	V1-T1-86
Padlock Brackets	V1-T1-86
Rainproof Conduit Hubs	V1-T1-68
Shunt Trip	V1-T1-86
Type CH Loadcenters and Circuit Breakers	V1-T1-21
Decorator Cover	V1-T1-25
Field Installation and Parts	V1-T1-21
Goof Collars	V1-T1-25, V1-T1-69
Ground Bar Kits	V1-T1-24
Handle Lockdogs	V1-T1-38
Handle Lockoffs	V1-T1-38
Handle Ties	V1-T1-38
Hold-Down Kits	V1-T1-38
Main Breaker Lug Kits	V1-T1-38
Mechanical Interlock Covers	V1-T1-22
Mechanical Interlocks	V1-T1-22, V1-T1-38
Mounting Bases	V1-T1-38
Neutral Bar Accessories	V1-T1-24
Phase Adapters	V1-T1-24
Rainproof Conduit Hubs	V1-T1-24
Shunt Trip	V1-T1-39
Admiral—SS	
Marina Power and Lighting Equipment	
Power Pedestals	V1-T5-62
Air Conditioning Disconnects	V1-T6-1–V1-T6-10
Cross-Reference	V1-T6-6
Ground Fault Receptacle	V1-T6-5
Molded Case Switch	V1-T6-2, V1-T6-4
Pullouts	
Fused	V1-T6-2, V1-T6-4
Non-Fused	V1-T6-2, V1-T6-4
Alarm Contacts	
Type BR Loadcenters and Circuit Breakers	
Accessories	V1-T1-86
Aluminum Meter Breakers	
Metering Products	
Meter Breakers	V1-T4-53



# Appendix 3—Alphabetical Product Index

ATS Kit  
 Automatic Transfer Switches . . . . . V1-T3-5

ATS Ready LC with factory-installed ATS kit  
 Automatic Transfer Switches . . . . . V1-T3-5

ATS Ready Loadcenter  
 Automatic Transfer Switches . . . . . V1-T3-5

Automatic Transfer Switches . . . . . V1-T3-2–V1-T3-6  
 ATS Ready LC with factory-installed ATS kit . . . . . V1-T3-5  
 ATS Ready Loadcenter . . . . . V1-T3-5  
 ATS Kit . . . . . V1-T3-5  
 Eaton’s Green Line . . . . . V1-T3-2  
 Fully Automatic Transfer Switches . . . . . V1-T3-2

Auxiliary Contact  
 Type BR Loadcenters and Circuit Breakers  
 Accessories . . . . . V1-T1-86

**B**

BR Circuit Breakers  
 BR Specialty Products  
 Type BR  
 Loadcenters and Circuit Breakers . . . . . V1-T1-77

BR Quick Connect Neutral Loadcenters  
 BR Specialty Products  
 Type BR  
 Loadcenters and Circuit Breakers . . . . . V1-T1-57

Breaker Plate  
 Marina Power and Lighting Equipment/  
 RV Park Hook-Ups  
 Accessories . . . . . V1-T5-75

Bus Bar Assembly  
 Marina Power and Lighting Equipment/  
 RV Park Hook-Ups  
 Accessories . . . . . V1-T5-76, V1-T5-77

**C**

Cable TV and Telephone Bracket  
 Temporary Power/RV Park  
 Accessories . . . . . V1-T5-7

CH Circuit Breakers  
 Type CH  
 Loadcenters and Circuit Breakers . . . . . V1-T1-31

CH Specialty Products  
 Non-Metallic Loadcenter . . . . . V1-T1-20

CH Style Renovation Solutions  
 Metering Products  
 Meter Breakers . . . . . V1-T4-54

Circuit Breakers  
 Marina Power and Lighting Equipment/  
 RV Park Hook-Ups  
 Accessories . . . . . V1-T5-75

Classified Circuit Breakers  
 Loadcenters and Circuit Breakers . . . . . V1-T1-96–V1-T1-100  
 Accessories . . . . . V1-T1-99  
 Type CH Replacement Breakers . . . . . V1-T1-97

Commercial Lever Bypass Sockets  
 Metering Products . . . . . V1-T4-10–V1-T4-16

Commercial Meter Stack Modules  
 Group Metering  
 Metering Products . . . . . V1-T4-122

Commercial Safety Sockets  
 Meter Breakers  
 Metering Products . . . . . V1-T4-55

Common Trip Quadplex Breakers  
 Type BR  
 Loadcenters and Circuit Breakers . . . . . V1-T1-83

Communications Grounding Device  
 Metering Products . . . . . V1-T4-34

Convertible Loadcenters MCB  
 Type BR  
 Loadcenters and Circuit Breakers . . . . . V1-T1-51  
 Type CH  
 Loadcenters and Circuit Breakers . . . . . V1-T1-10

Convertible Loadcenters MLO  
 Type BR  
 Loadcenters and Circuit Breakers . . . . . V1-T1-51  
 Type CH  
 Loadcenters and Circuit Breakers . . . . . V1-T1-10

Cover Set  
 Marina Power and Lighting Equipment/  
 RV Park Hook-Ups  
 Accessories . . . . . V1-T5-75

Cross-Reference  
 Metering Products . . . . . V1-T4-25

**D**

Decorator Cover  
 Type CH Loadcenters and Circuit Breakers  
 Accessories . . . . . V1-T1-25

Digital Electronic Kilowatt-hour Meters  
 Marina Power and Lighting Equipment  
 Power Pedestals . . . . . V1-T5-81  
 RV Park Hook-Ups  
 Power Pedestals . . . . . V1-T5-44

Digital Electronic Meters  
 Marina Power and Lighting Equipment/  
 RV Park Hook-Ups  
 Accessories . . . . . V1-T5-76

Direct Feed Kit  
 Mobile Home Panels  
 Accessories . . . . . V1-T5-23

Distribution Equipment—Ground Fault Monitor  
 Marina Power and Lighting Equipment  
 Power Pedestals . . . . . V1-T5-82

Distribution Equipment—MegaYacht Powerpoint  
 Marina Power and Lighting Equipment  
 Power Pedestals . . . . . V1-T5-83

Distribution Equipment—Panels	
Marina Power and Lighting Equipment	
Power Pedestals . . . . .	V1-T5-89
Power Pedestals	
RV Park Hook-Ups . . . . .	V1-T5-49
Distribution Equipment—Substations	
Marina Power and Lighting Equipment	
Power Pedestals . . . . .	V1-T5-86
Distribution Equipment—Transformers	
Marina Power and Lighting Equipment	
Power Pedestals . . . . .	V1-T5-90
Distribution—Ground Fault Monitor	
RV Park Hook-Ups	
Power Pedestals . . . . .	V1-T5-45
Distribution—Substations	
RV Park Hook-Ups	
Power Pedestals . . . . .	V1-T5-46
Distribution—Transformers	
RV Park Hook-Ups	
Power Pedestals . . . . .	V1-T5-50
Door Hasp	
Marina Power and Lighting Equipment/ RV Park Hook-Ups	
Accessories . . . . .	V1-T5-77

## E

Eaton Terms & Conditions	
Freight . . . . .	V1-A1-3
Limitation of Liability . . . . .	V1-A1-5
Terms and Conditions of Sale . . . . .	V1-A1-1
Terms of Payment . . . . .	V1-A1-2
Warranty . . . . .	V1-A1-3
Eaton’s Green Line	
Automatic Transfer Switches . . . . .	V1-T3-2
Emergency Generator Panels	
Manual Transfer Switches . . . . .	V1-T3-7–V1-T3-9
Emergency Power Panels	
Manual Transfer Switches . . . . .	V1-T3-7
Enclosed Breakers	
Loadcenters and Circuit Breakers . . . . .	V1-T1-94–V1-T1-95
EUSERC Requirements Service Entrance Devices	
Meter Breakers	
Metering Products . . . . .	V1-T4-41
External Cover	
Marina Power and Lighting Equipment/ RV Park Hook-Ups	
Accessories . . . . .	V1-T5-76

## F

Faceplate	
Marina Power and Lighting Equipment/ RV Park Hook-Ups	
Accessories . . . . .	V1-T5-75–V1-T5-77
Factory-Installed Surge Protection	
Surge Protection Devices and Lightning Arresters . . . . .	V1-T2-2, V1-T2-9

Field Installation and Parts	
Type BR Loadcenters and Circuit Breakers	
Accessories . . . . .	V1-T1-63
Type CH Loadcenters and Circuit Breakers	
Accessories . . . . .	V1-T1-21
Filler Plates	
Type BR Loadcenters and Circuit Breakers	
Accessories . . . . .	V1-T1-63
Fire Extinguisher	
Marina Power and Lighting Equipment/ RV Park Hook-Ups	
Accessories . . . . .	V1-T5-77
Firehouse	
Marina Power and Lighting Equipment	
Power Pedestals . . . . .	V1-T5-73
RV Park Hook-Ups	
Power Pedestals . . . . .	V1-T5-42
Fluorescent Light Assembly	
Marina Power and Lighting Equipment/ RV Park Hook-Ups	
Accessories . . . . .	V1-T5-75
Fluorescent Light Kit	
Temporary Power/RV Park	
Accessories . . . . .	V1-T5-7
Flush Flange Kit	
Manual Transfer Switches . . . . .	V1-T3-9
Flushmount Kit	
Surge Protection Devices and Lightning Arresters . . . . .	V1-T2-6
Fully Automatic Transfer Switches	
Automatic Transfer Switches . . . . .	V1-T3-2
Fuse Holder	
Marina Power and Lighting Equipment/ RV Park Hook-Ups	
Accessories . . . . .	V1-T5-76
Fused, Unfused and Molded Case Switch	
Air Conditioning Disconnects . . . . .	V1-T6-2–V1-T6-10

## G

Goof Collars	
Type CH Loadcenters and Circuit Breakers	
Accessories . . . . .	V1-T1-25, V1-T1-69
Ground Bar Kits	
Type BR Loadcenters and Circuit Breakers	
Accessories . . . . .	V1-T1-68, V1-T1-93
Type CH Loadcenters and Circuit Breakers	
Accessories . . . . .	V1-T1-24
Ground Fault Receptacle	
Air Conditioning Disconnects . . . . .	V1-T6-5
Group Metering	
Metering Products	
Accessories . . . . .	V1-T4-30, V1-T4-138
Commercial Meter Stack Modules . . . . .	V1-T4-122
Renewal Parts . . . . .	V1-T4-137, V1-T4-139
Residential Meter Stacks . . . . .	V1-T4-106

# Appendix 3—Alphabetical Product Index

## H

Handle Lockdogs	
Type CH Loadcenters and Circuit Breakers	
Accessories . . . . .	V1-T1-38
Handle Lockoffs	
Type BR Loadcenters and Circuit Breakers	
Accessories . . . . .	V1-T1-85
Type CH Loadcenters and Circuit Breakers	
Accessories . . . . .	V1-T1-38
Handle Ties	
Type BR Loadcenters and Circuit Breakers	
Accessories . . . . .	V1-T1-85
Type CH Loadcenters and Circuit Breakers	
Accessories . . . . .	V1-T1-38
Hatteras Light	
Marina Power and Lighting Equipment	
Power Pedestals . . . . .	V1-T5-69
Hold-Down Kits	
Type BR Loadcenters and Circuit Breakers	
Accessories . . . . .	V1-T1-86
Hose and Cable Brackets	
Marina Power and Lighting Equipment/ RV Park Hook-Ups	
Accessories . . . . .	V1-T5-75
House Panels	
Meter Breakers	
Accessories . . . . .	V1-T4-50
Metering Products . . . . .	V1-T4-48

## I

Instrument Rated Sockets	
Metering Products . . . . .	V1-T4-23, V1-T4-24
Isolation Plate	
Marina Power and Lighting Equipment/ RV Park Hook-Ups	
Accessories . . . . .	V1-T5-75

## L

Lens	
Marina Power and Lighting Equipment/ RV Park Hook-Ups	
Accessories . . . . .	V1-T5-77
Life Ring	
Marina Power and Lighting Equipment/ RV Park Hook-Ups	
Accessories . . . . .	V1-T5-77
Light and Lens Assembly	
Marina Power and Lighting Equipment/ RV Park Hook-Ups	
Accessories . . . . .	V1-T5-75
Light Fuse	
Marina Power and Lighting Equipment/ RV Park Hook-Ups	
Accessories . . . . .	V1-T5-76, V1-T5-77

Light Holder	
Marina Power and Lighting Equipment/ RV Park Hook-Ups	
Accessories . . . . .	V1-T5-77
Lighthouse	
Marina Power and Lighting Equipment	
Power Pedestals . . . . .	V1-T5-54
Lighthouse—SS	
Marina Power and Lighting Equipment	
Power Pedestals . . . . .	V1-T5-58
Loadcenter Interiors/OEM Loadcenters	
Loadcenters and Circuit Breakers . . . . .	V1-T1-89–V1-T1-93
Loadcenters and Circuit Breakers . . . . .	V1-T1-1–V1-T1-95, V1-T1-97–V1-T1-100
Classified Circuit Breakers . . . . .	V1-T1-96–V1-T1-100
Accessories . . . . .	V1-T1-99
Type CH Replacement Breakers . . . . .	V1-T1-97
Enclosed Breakers . . . . .	V1-T1-94–V1-T1-95
Loadcenter Interiors/OEM Loadcenters . . . . .	V1-T1-89–V1-T1-93
Type BR . . . . .	V1-T1-42–V1-T1-70
Accessories . . . . .	V1-T1-63
BR Specialty Products	
BR Circuit Breakers . . . . .	V1-T1-77
BR Quick Connect Neutral Loadcenters . . . . .	V1-T1-57
Riser Panel . . . . .	V1-T1-59
Spa Panels . . . . .	V1-T1-58
Type BR Renovation Loadcenter . . . . .	V1-T1-60
Type BR Retrofit Interior Kits . . . . .	V1-T1-61
Common Trip Quadplex Breakers . . . . .	V1-T1-83
Convertible Loadcenters MCB . . . . .	V1-T1-51
Convertible Loadcenters MLO . . . . .	V1-T1-51
Plug-On Circuit Breakers . . . . .	V1-T1-77
Single-Phase . . . . .	V1-T1-48
Three-Phase . . . . .	V1-T1-54
Type CH . . . . .	V1-T1-2–V1-T1-30
Accessories . . . . .	V1-T1-21
CH Circuit Breakers . . . . .	V1-T1-31
CH Specialty Products	
Non-Metallic Loadcenter . . . . .	V1-T1-20
Plug-On Neutral Loadcenter . . . . .	V1-T1-16
Spa Panels . . . . .	V1-T1-13
Surge Panel . . . . .	V1-T1-14
Type CH Renovation Loadcenter . . . . .	V1-T1-17
Type CH Retrofit Interior Kits . . . . .	V1-T1-18
Convertible Loadcenters MCB . . . . .	V1-T1-10
Convertible Loadcenters MLO . . . . .	V1-T1-10
Single-Phase . . . . .	V1-T1-6
Three-Phase . . . . .	V1-T1-11

## M

Main and Sub-Feed Lug Blocks	
Type BR Loadcenters and Circuit Breakers	
Accessories . . . . .	V1-T1-63
Main Breaker Lug Kits	
Type BR Loadcenters and Circuit Breakers	
Accessories . . . . .	V1-T1-86
Type CH Loadcenters and Circuit Breakers	
Accessories . . . . .	V1-T1-38

Main Door		Meter Breakers	
Marina Power and Lighting Equipment/ RV Park Hook-Ups		Accessories . . . . .	V1-T4-58
Accessories . . . . .	V1-T5-75, V1-T5-77	House Panels	
Main Housing		Accessories . . . . .	V1-T4-50
Marina Power and Lighting Equipment/ RV Park Hook-Ups		Metering Products	
Accessories . . . . .	V1-T5-75–V1-T5-77	Aluminum Meter Breakers . . . . .	V1-T4-53
Main Lugs		CH Style Renovation Solutions . . . . .	V1-T4-54
Type BR Loadcenters and Circuit Breakers		Commercial Safety Sockets . . . . .	V1-T4-55
Accessories . . . . .	V1-T1-63	EUSERC Requirements Service	
Manual Transfer Switches . . . . .	V1-T3-7–V1-T3-10	Entrance Devices . . . . .	V1-T4-41
Emergency Generator Panels . . . . .	V1-T3-7	House Panels . . . . .	V1-T4-48
Emergency Power Panels . . . . .	V1-T3-7	Non-EUSERC Combination Service	
Generator Panels . . . . .	V1-T3-9	Entrance Devices . . . . .	V1-T4-37
Indoor and Outdoor Designs . . . . .	V1-T3-8	Residential Meter Breakers . . . . .	V1-T4-35
Indoor and Outdoor Designs . . . . .	V1-T3-7	West Coast All-In-One Design . . . . .	V1-T4-44
Standard Manual Transfer Switch . . . . .	V1-T3-9	Metering Products . . . . .	V1-T4-1–V1-T4-140
Switched Neutral Manual Transfer Switch . . . . .	V1-T3-9	Commercial Lever Bypass Sockets . . . . .	V1-T4-10–V1-T4-16
Marina Power and Lighting Equipment		Communications Grounding Device . . . . .	V1-T4-34
Power Pedestals . . . . .	V1-T5-2, V1-T5-51–V1-T5-90	Cross-Reference . . . . .	V1-T4-25
Admiral—SS . . . . .	V1-T5-62	Group Metering	
Digital Electronic Kilowatthour Meters . . . . .	V1-T5-81	Accessories . . . . .	V1-T4-30, V1-T4-132, V1-T4-136, V1-T4-138
Distribution Equipment—Ground Fault Monitor . . . . .	V1-T5-82	Commercial Meter Stack Modules . . . . .	V1-T4-122
Distribution Equipment—MegaYacht Powerpoint . . . . .	V1-T5-83	Renewal Parts . . . . .	V1-T4-137, V1-T4-139
Distribution Equipment—Panels . . . . .	V1-T5-89	Residential Meter Stacks . . . . .	V1-T4-106
Distribution Equipment—Substations . . . . .	V1-T5-86	Instrument Rated Sockets . . . . .	V1-T4-23, V1-T4-24
Distribution Equipment—Transformers . . . . .	V1-T5-90	Mechanical Lugs . . . . .	V1-T4-33
Firehouse . . . . .	V1-T5-73	Meter Breakers	
Hatteras Light . . . . .	V1-T5-69	Aluminum Meter Breakers . . . . .	V1-T4-53
Lighthouse . . . . .	V1-T5-54	CH Style Renovation Solutions . . . . .	V1-T4-54
Lighthouse—SS . . . . .	V1-T5-58	Commercial Safety Sockets . . . . .	V1-T4-55
Mariner . . . . .	V1-T5-80	EUSERC Requirements Service	
Newport Harbor Mate . . . . .	V1-T5-65	Entrance Devices . . . . .	V1-T4-41
Smart Start . . . . .	V1-T5-79	House Panels . . . . .	V1-T4-48
Marina Power and Lighting Equipment/ RV Park Hook-Ups		Non-EUSERC Combination Service	
Power Pedestals		Entrance Devices . . . . .	V1-T4-37
Accessories . . . . .	V1-T5-75	Residential Meter Breakers . . . . .	V1-T4-35
Mariner		West Coast All-In-One Design . . . . .	V1-T4-44
Marina Power and Lighting Equipment		Meter Socket Accessories	
Power Pedestals . . . . .	V1-T5-80	Accessories . . . . .	V1-T4-31
Mechanical Interlock Covers		Multiple Position Horizontal	
Type BR Loadcenters and Circuit Breakers		Ganged Sockets . . . . .	V1-T4-17–V1-T4-34
Accessories . . . . .	V1-T1-66	Residential Pedestals . . . . .	V1-T4-28, V1-T4-29
Type CH Loadcenters and Circuit Breakers		Single Meter Sockets	
Accessories . . . . .	V1-T1-22	Residential Ringless Type Cover . . . . .	V1-T4-4
Mechanical Interlocks		Tenant Main Circuit Breaker	
Type BR Loadcenters and Circuit Breakers		Type BR . . . . .	V1-T4-116
Accessories . . . . .	V1-T1-86	Type CCV . . . . .	V1-T4-118
Type CH Loadcenters and Circuit Breakers		Type CV . . . . .	V1-T4-119, V1-T4-121
Accessories . . . . .	V1-T1-22, V1-T1-38	Mobile Home Panels	
Mechanical Lugs		Accessories	
Meter Socket Accessories . . . . .	V1-T4-33	Power Pedestals . . . . .	V1-T5-23
		Power Pedestals . . . . .	V1-T5-2, V1-T5-21–V1-T5-27
		Molded Case Switch	
		Air Conditioning Disconnects . . . . .	V1-T6-2, V1-T6-4
		Mounting Bases	
		Type CH Loadcenters and Circuit Breakers	
		Accessories . . . . .	V1-T1-38

# Appendix 3—Alphabetical Product Index

- Mounting Brackets
  - Marina Power and Lighting Equipment/  
RV Park Hook-Ups  
Accessories . . . . . V1-T5-77
- Mounting Feet
  - Marina Power and Lighting Equipment/  
RV Park Hook-Ups  
Accessories . . . . . V1-T5-76
- Multiple Position Horizontal Ganged Sockets
  - Metering Products . . . . . V1-T4-17-V1-T4-34

## N

- Neutral Bar Accessories
  - Type CH Loadcenters and Circuit Breakers  
Accessories . . . . . V1-T1-24
- Newport Camp Mate Power Pedestal
  - RV Park Hook-Ups  
Power Pedestals . . . . . V1-T5-36
- Newport Harbor Mate
  - Marina Power and Lighting Equipment  
Power Pedestals . . . . . V1-T5-65
- Non-EUSERC Combination Service Entrance Devices
  - Metering Products  
Meter Breakers . . . . . V1-T4-37
- Non-Metallic Loadcenter
  - CH Specialty Products  
Type CH  
Loadcenters and Circuit Breakers . . . . . V1-T1-20

## O

- Outdoor Communication Grounding Device
  - Surge Protection Devices and Lightning Arresters . . . . V1-T2-6

## P

- Padlock Brackets
  - Type BR Loadcenters and Circuit Breakers  
Accessories . . . . . V1-T1-86
- Padmount Adapter
  - Mobile Home Panels  
Accessories . . . . . V1-T5-23
- Pad-Mount Bracket
  - Temporary Power/RV Park  
Accessories . . . . . V1-T5-7
- Park Light Power Pedestal
  - RV Park Hook-Ups  
Power Pedestals . . . . . V1-T5-39
- Pedestal Extension
  - Mobile Home Panels  
Accessories . . . . . V1-T5-23
  - Temporary Power/RV Park  
Accessories . . . . . V1-T5-7
- Pedestal Units
  - Temporary Power/RV Park  
Power Pedestals . . . . . V1-T5-16

- Phase Adapters
  - Type CH Loadcenters and Circuit Breakers  
Accessories . . . . . V1-T1-24
- Phone, Cable, Internet Assemblies
  - Marina Power and Lighting Equipment/  
RV Park Hook-Ups  
Accessories . . . . . V1-T5-76
- Plug-On Circuit Breakers
  - Type BR  
Loadcenters and Circuit Breakers . . . . . V1-T1-77
- Plug-On Neutral Loadcenter
  - CH Specialty Products  
Type CH  
Loadcenters and Circuit Breakers . . . . . V1-T1-16
- Plug-On Surge Protection
  - Surge Protection Devices and Lightning Arrester . . . . V1-T2-3
- Power Inlet Box
  - Manual Transfer Switches . . . . . V1-T3-9
- Power Outlet Panels
  - Power Pedestals . . . . . V1-T5-2
- Power Pedestals . . . . . V1-T5-1-V1-T5-90
  - Marina Power and Lighting Equipment . . . . . V1-T5-2,  
V1-T5-51-V1-T5-90
  - Admiral—SS . . . . . V1-T5-62
  - Digital Electronic Kilowatthour Meters . . . . . V1-T5-81
  - Distribution Equipment—Ground Fault Monitor . . . . V1-T5-82
  - Distribution Equipment—MegaYacht Powerpoint . . V1-T5-83
  - Distribution Equipment—Panels . . . . . V1-T5-89
  - Distribution Equipment—Substations . . . . . V1-T5-86
  - Distribution Equipment—Transformers . . . . . V1-T5-90
  - Firehouse . . . . . V1-T5-73
  - Hatteras Light . . . . . V1-T5-69
  - Lighthouse . . . . . V1-T5-54
  - Lighthouse—SS . . . . . V1-T5-58
  - Mariner . . . . . V1-T5-80
  - Newport Harbor Mate . . . . . V1-T5-65
  - Smart Start . . . . . V1-T5-79
- Marina Power and Lighting Equipment/  
RV Park Hook-Ups
  - Accessories . . . . . V1-T5-75
- Mobile Home Panels . . . . . V1-T5-2, V1-T5-21-V1-T5-27
  - Accessories . . . . . V1-T5-23
- Power Outlet Panels . . . . . V1-T5-2
- RV Park Hook-Ups . . . . . V1-T5-28-V1-T5-50
  - Digital Electronic Kilowatthour Meters . . . . . V1-T5-44
  - Distribution Equipment—Panels . . . . . V1-T5-49
  - Distribution—Ground Fault Monitor . . . . . V1-T5-45
  - Distribution—Substations . . . . . V1-T5-46
  - Distribution—Transformers . . . . . V1-T5-50
  - Firehouse . . . . . V1-T5-42
  - Newport Camp Mate Power Pedestal . . . . . V1-T5-36
  - Park Light Power Pedestal . . . . . V1-T5-39
  - Powerhouse Power Pedestal . . . . . V1-T5-30
  - Powerhouse Stainless Steel Power Pedestal . . . . . V1-T5-33
  - Temporary Power/RV Park . . . . . V1-T5-3-V1-T5-20
  - Accessories . . . . . V1-T5-7
  - Pedestal Units . . . . . V1-T5-16
  - Surface Units . . . . . V1-T5-10

Powerhouse Power Pedestal  
 RV Park Hook-Ups  
 Power Pedestals . . . . . V1-T5-30

Powerhouse Stainless Steel Power Pedestal  
 RV Park Hook-Ups  
 Power Pedestals . . . . . V1-T5-33

Pullouts, Fused and Non-Fused  
 Air Conditioning Disconnects . . . . . V1-T6-2, V1-T6-4

## Q

Quick Connect Design  
 Surge Protection Devices and Lightning Arresters . . . . V1-T2-6

## R

Rainproof Conduit Hub  
 Temporary Power/RV Park  
 Accessories . . . . . V1-T5-7

Rainproof Conduit Hubs  
 Type BR Loadcenters and Circuit Breakers  
 Accessories . . . . . V1-T1-68

Type CH Loadcenters and Circuit Breakers  
 Accessories . . . . . V1-T1-24

Raintight Enclosure  
 Surge Protection Devices and Lightning Arresters . . . . V1-T2-6

Receptacles  
 Marina Power and Lighting Equipment/  
 RV Park Hook-Ups  
 Accessories . . . . . V1-T5-75

Renewal Parts  
 Group Metering  
 Metering Products . . . . . V1-T4-137, V1-T4-139

Temporary Power/RV Park  
 Accessories . . . . . V1-T5-8

Residential Backup Transfer Switch Solutions . . . . V1-T3-2–V1-T3-10

Automatic Transfer Switches . . . . . V1-T3-2–V1-T3-6

Manual Transfer Switches . . . . . V1-T3-7–V1-T3-10

Residential Meter Breakers  
 Meter Breakers  
 Metering Products . . . . . V1-T4-35

Residential Meter Stacks  
 Group Metering  
 Metering Products . . . . . V1-T4-106

Meter Packs—1MP, 1MM and 3MM . . . . . V1-T4-88

Residential Pedestals  
 Metering Products . . . . . V1-T4-28, V1-T4-29

Residential Ringless Type Cover  
 Single Meter Sockets  
 Metering Products . . . . . V1-T4-4

Riser Panel  
 BR Specialty Products  
 Type BR  
 Loadcenters and Circuit Breakers . . . . . V1-T1-59

RV Park Hook-Ups  
 Power Pedestals . . . . . V1-T5-28–V1-T5-50

Digital Electronic Kilowatt-hour Meters . . . . . V1-T5-44

Distribution Equipment—Panels . . . . . V1-T5-49

Distribution—Ground Fault Monitor . . . . . V1-T5-45

Distribution—Substations . . . . . V1-T5-46

Distribution—Transformers . . . . . V1-T5-50

Firehouse . . . . . V1-T5-42

Newport Camp Mate Power Pedestal . . . . . V1-T5-36

Park Light Power Pedestal . . . . . V1-T5-39

Powerhouse Power Pedestal . . . . . V1-T5-30

Powerhouse Stainless Steel Power Pedestal . . . . . V1-T5-33

## S

Safety Sockets, Commercial  
 Meter Breakers  
 Metering Products . . . . . V1-T4-55

Service Entrance Surge Protection  
 Surge Protection Devices and Lightning Arresters . . . . V1-T2-2

Shunt Trip  
 Type BR Loadcenters and Circuit Breakers  
 Accessories . . . . . V1-T1-86

Type CH Loadcenters and Circuit Breakers  
 Accessories . . . . . V1-T1-39

Single Meter Sockets  
 Metering Products  
 Residential Ringless Type Cover . . . . . V1-T4-4

Single-Phase  
 Type BR  
 Loadcenters and Circuit Breakers . . . . . V1-T1-48

Type CH  
 Loadcenters and Circuit Breakers . . . . . V1-T1-6

Smart Start  
 Marina Power and Lighting Equipment  
 Power Pedestals . . . . . V1-T5-79

Spa Panels  
 BR Specialty Products  
 Type BR  
 Loadcenters and Circuit Breakers . . . . . V1-T1-58

CH Specialty Products  
 Type CH  
 Loadcenters and Circuit Breakers . . . . . V1-T1-13

Type BR . . . . . V1-T1-58

Spring Closure  
 Marina Power and Lighting Equipment/  
 RV Park Hook-Ups  
 Accessories . . . . . V1-T5-75

Standard Manual Transfer Switch  
 Manual Transfer Switches . . . . . V1-T3-9

Strobe Light  
 Marina Power and Lighting Equipment/  
 RV Park Hook-Ups  
 Accessories . . . . . V1-T5-77

Surface Units  
 Temporary Power/RV Park  
 Power Pedestals . . . . . V1-T5-10

# Appendix 3—Alphabetical Product Index

- Surge Installed Loadcenters
  - Surge Protection Devices and Lightning Arrester . . . . V1-T2-9
- Surge Panel
  - CH Specialty Products
    - Type CH
      - Loadcenters and Circuit Breakers . . . . . V1-T1-14
- Surge Protection . . . . . V1-T2-1–V1-T2-10
  - Factory-Installed Surge Protection . . . . . V1-T2-2, V1-T2-9
  - Plug-On Surge Protection . . . . . V1-T2-3
    - Type 3 Point-of-Use Surge Protection . . . . . V1-T2-3
    - Type BRSURGE . . . . . V1-T2-3
    - Type BRSURGECSA . . . . . V1-T2-3
    - Type CHQSA . . . . . V1-T2-3
    - Type CHSA . . . . . V1-T2-3
    - Type CLSURGE . . . . . V1-T2-3
  - Service Entrance . . . . . V1-T2-2
  - Surge Installed Loadcenters . . . . . V1-T2-9
  - Surge Protection Devices and
    - Lightning Arresters . . . . . V1-T2-2–V1-T2-10
  - Surge Ready Loadcenter . . . . . V1-T2-2, V1-T2-9
  - Two-Stage Protection . . . . . V1-T2-2, V1-T2-3
  - UL 1449 3rd Edition Surge Protection
    - Type 1 . . . . . V1-T2-2
      - Type 1 CHSP . . . . . V1-T2-4
    - Type 2 . . . . . V1-T2-2
      - Type 2 Plug-On . . . . . V1-T2-10
  - UL 1449 3rd Edition, cUL
    - Type 2 CHSP Service Entrance . . . . . V1-T2-5
- Surge Protection Devices and
  - Lightning Arresters . . . . . V1-T2-2–V1-T2-10
    - Surge Protection Receptacles with
      - LED Indicators and Audible Alarm . . . . . V1-T2-8
    - Type BR and CH Surge Breakers . . . . . V1-T2-7
- Surge Protection Receptacles with LED Indicators
  - and Audible Alarm
    - Surge Protection Devices and Lightning Arresters . . . . V1-T2-8
- Surge Ready
  - Type CH
    - Loadcenters and Circuit Breakers . . . . . V1-T1-15
- Surge Ready Loadcenter . . . . . V1-T2-9
  - Surge Protection Devices and Lightning Arresters . . . . V1-T2-2
- Switched Neutral Manual Transfer Switch
  - Manual Transfer Switches . . . . . V1-T3-9

## T

- Temporary Power/RV Park
  - Power Pedestals . . . . . V1-T5-3–V1-T5-20
    - Accessories . . . . . V1-T5-7
    - Pedestal Units . . . . . V1-T5-16
    - Surface Units . . . . . V1-T5-10
- Three-Phase
  - Type BR
    - Loadcenters and Circuit Breakers . . . . . V1-T1-54
  - Type CH
    - Loadcenters and Circuit Breakers . . . . . V1-T1-11
- Transfer Panels
  - Manual Transfer Switches . . . . . V1-T3-7

- Two-Stage Protection
  - Surge Protection Devices and
    - Lightning Arresters . . . . . V1-T2-2, V1-T2-3
- Type 1 Surge Protective Device
  - Surge Protection Devices and Lightning Arresters . . . . V1-T2-2
- Type 2 Surge Protective Device
  - Surge Protection Devices and Lightning Arresters . . . . V1-T2-2
- Type 3 Point-of-Use Surge Protection
  - Surge Protection Devices and Lightning Arresters . . . . V1-T2-3
- Type BR
  - Loadcenters and Circuit Breakers . . . . . V1-T1-42–V1-T1-70
    - Accessories . . . . . V1-T1-63
  - BR Specialty Products
    - BR Circuit Breakers . . . . . V1-T1-77
    - BR Quick Connect Neutral Loadcenters . . . . . V1-T1-57
    - Riser Panel . . . . . V1-T1-59
    - Spa Panels . . . . . V1-T1-58
      - Type BR Renovation Loadcenter . . . . . V1-T1-60
      - Type BR Retrofit Interior Kits . . . . . V1-T1-61
    - Common Trip Quadplex Breakers . . . . . V1-T1-83
    - Convertible Loadcenters MCB . . . . . V1-T1-51
    - Convertible Loadcenters MLO . . . . . V1-T1-51
    - Plug-On Circuit Breakers . . . . . V1-T1-77
    - Single-Phase . . . . . V1-T1-48
    - Spa Panels . . . . . V1-T1-58
      - Three-Phase . . . . . V1-T1-54
  - Type BR and CH Surge Breakers
    - Surge Protection Devices and Lightning Arresters . . . . V1-T2-7
  - Type BR Renovation Loadcenter
    - BR Specialty Products
      - Type BR
        - Loadcenters and Circuit Breakers . . . . . V1-T1-60
    - Type BR Retrofit Interior Kits
      - BR Specialty Products
        - Type BR
          - Loadcenters and Circuit Breakers . . . . . V1-T1-61
  - Type BRSURGE Surge Protection
    - Surge Protection Devices and Lightning Arresters . . . . V1-T2-3
- Type CH . . . . . V1-T1-15
  - Loadcenters and Circuit Breakers . . . . . V1-T1-2–V1-T1-30
    - Accessories . . . . . V1-T1-21
    - CH Circuit Breakers . . . . . V1-T1-31
    - CH Specialty Products
      - Non-Metallic Loadcenter . . . . . V1-T1-20
      - Plug-On Neutral Loadcenter . . . . . V1-T1-16
      - Spa Panels . . . . . V1-T1-13
      - Surge Panel . . . . . V1-T1-14
      - Type CH Renovation Loadcenter . . . . . V1-T1-17
      - Type CH Retrofit Interior Kits . . . . . V1-T1-18
      - Convertible Loadcenters MCB . . . . . V1-T1-10
      - Convertible Loadcenters MLO . . . . . V1-T1-10
      - Single-Phase . . . . . V1-T1-6
      - Surge Ready . . . . . V1-T1-15
      - Three-Phase . . . . . V1-T1-11
- Type CH Renovation Loadcenter
  - CH Specialty Products
    - Type CH
      - Loadcenters and Circuit Breakers . . . . . V1-T1-17

Type CH Replacement Breakers  
 Classified Circuit Breakers  
     Loadcenters and Circuit Breakers . . . . . V1-T1-97

Type CH Retrofit Interior Kits  
 CH Specialty Products  
     Type CH  
         Loadcenters and Circuit Breakers . . . . . V1-T1-18

Type CHQSA Surge Protection  
     Surge Protection Devices and Lightning Arresters . . . . V1-T2-3

Type CHSA Surge Protection  
     Surge Protection Devices and Lightning Arresters . . . . V1-T2-3

Type CLSURGE Surge Protection  
     Surge Protection Devices and Lightning Arresters . . . . V1-T2-3

**U**

UL 1449 3rd Edition  
     Surge Protection Devices and Lightning Arrester. . . . . V1-T2-2

**W**

Water Assemblies  
     Marina Power and Lighting Equipment/  
         RV Park Hook-Ups  
         Accessories . . . . . V1-T5-76

West Coast All-In-One Design  
     Meter Breakers  
         Metering Products . . . . . V1-T4-44