

AIR TOOLS CARPENTER

23 Gauge 1-3/8 Inch Pin Nailer

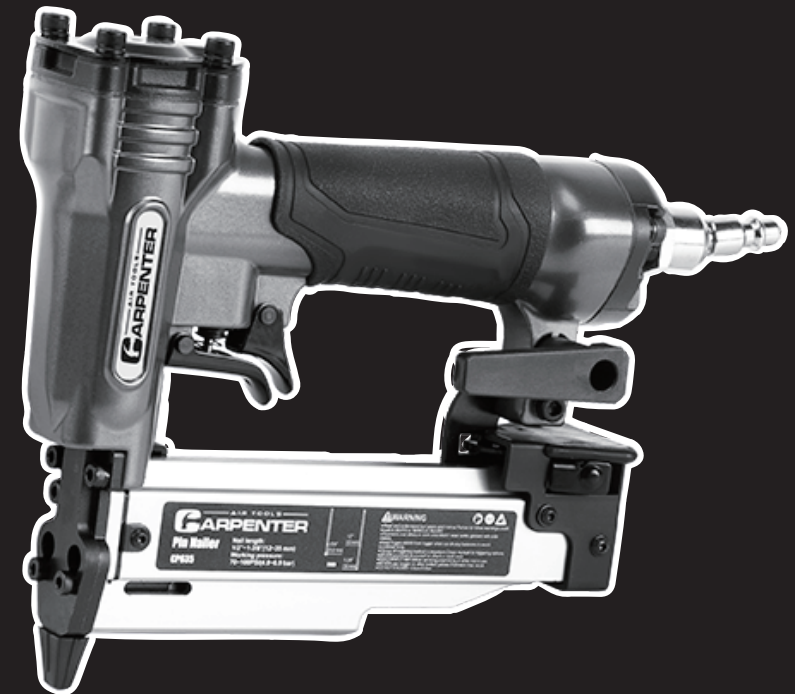

Model No. CP635

IMPORTANT:
Please read this manual carefully before
using this product, and save it for reference.

**INSTRUCTION
MANUAL**

Contact us



info@carpenterpowertools.com



Carpenter Power Tools
359 Hood Rd. Suite #230
Jasper, GA, 30143



1-888-666-1887



<http://www.carpenterpowertools.com>

TABLE OF CONTENTS

TECHNICAL SPECIFICATIONS	4
SAFETY GUIDELINES	5
KEY PARTS DIAGRAM	8
TECHNICAL INFORMATION	9
TYPES OF NAILS	10
OPERATING INSTRUCTIONS	11
MAINTENANCE	15
TROUBLESHOOTING	16
EXPLODED VIEW	18
PARTS LIST	19

TECHNICAL SPECIFICATIONS

Operating pressure	70 – 100 psi (4.8 – 6.9bar 4.9 – 7 kgf/cm ²)
Working Air Hose	Air hose inner diameter of 7mm and length no more than 30 meters
Dimensions (Length*Height*Width)	9.9"(L)x7.4"(H)x2.4"(W) (251mmx189mmx61mm)
Net Weight	2.38 lbs (1.08kg)
Nail capacity	100 nails (1 strip)
Nail Spec.	5/8" - 1-3/8"
Air consumption	0.01 ft ³ /cycle at 90 psi
	(0.29 ltr/cycle at 6.9 bar)
	(0.29 ltr/cycle at 7 kgf/cm ²)
Air inlet	1/4 NPT Thread

CFM: Cubic feet per minute refers to the volumetric flow of air. This information is used to determine the proper compressor to suit your needs.

NPT: National Pipe Thread.

SAFETY GUIDELINES

This manual contains information that relates to PROTECTING PERSONAL SAFETY and PREVENTING EQUIPMENT PROBLEMS. It is very important to read this manual carefully and understand it thoroughly before using the product. The symbols listed below are used to indicate this information.



DANGER!

Potential hazard that could result in serious personal injury including possible death.



WARNING!

Potential hazard that could result in serious personal injury to the tool user or others in the work area.



CAUTION!

Potential hazard that could result in damage to the tool or property.

PERSONAL SAFETY

These precautions are intended for the personal safety of the user and others working with the user. Please take time to read and understand them.

Make sure you read and understand this manual before using this tool. Make sure other users read and understand this manual before they use the tool.

SAFETY GUIDELINES

- **DANGER!** Potential hazard that could result in serious personal injury including possible death.
- Do not use oxygen or any other combustible or bottled gas to power air-powered tools. Failure to observe this warning can cause explosion and serious personal injury or death.
- Do not use this tool in the presence of flammable liquids, dust or gases. Sparks that are created during use may ignite these materials.
- Use only compressed air to power air-powered tools. Use an approved air hose with a minimum length of 25' (7.6 m).
- Do not allow inexperienced or untrained individuals to operate any air-powered tool.
- Keep hands and other parts of the body away from the Outlet (Firing Head) during use.
- Nails or objects in the workpiece can cause serious injury if they are deflected by the workpiece.
- Keep children away from the work area. Do not allow children to handle power tools.
- Never point nailer toward yourself or anyone else.
- Always assume the nailer contains fasteners. Never point the nailer toward yourself or anyone else, whether it contains fasteners or not. If fasteners are mistakenly driven, it can lead to severe injuries. Never engage in horseplay with the nailer. Respect the nailer as a dangerous working implement.

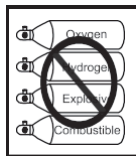

CAUTION!

Potential hazard that could result in damage to the tool or property.

- Disconnect the tool from the air supply and turn off the compressor before performing any maintenance, when the tool is not in use, when it is being handed to another person, when it is left unattended, or when loading and changing nails. Failure to comply may result in injury or damage to equipment.
- Do not exceed the maximum or minimum pressures. Operating the tool at the wrong pressure (too low or too high) may cause excessive noise or rapid wear.
- Use only Non-Detergent Air Tool Lubricating Oil for this tool.
- Near and below freezing, moisture in the air line may freeze and prevent tool operation. Do not store in a cold weather environment to prevent frost or ice formation. Frost and ice on the tools operating valves and mechanisms could cause tool failure.

NOTE: Some commercial air line drying liquids are harmful to "O" rings and seals—
Do not use these low temperature air dryers without checking compatibility.



WARNING!

Potential hazard that could result in serious personal injury to the tool user or others in the work area.

- Always wear eye and hearing protection when using the air compressor. Failure to do so may result in sight or hearing loss.
- Do not overload the tool. Allow the tool to operate at its optimum speed for maximum efficiency.
- Do not point the tool towards yourself or other people, even when the tool has stopped. Keep hands, feet, and all other parts of the body clear from work area.
- Do not attempt to clear nailer jams while the air hose is connected.
- Do not keep the trigger or the Push Lever pressed while loading nails.

No.	Description	No.	Description
①	Top Cover	⑨	Magazine
②	Piston O-Ring	⑩	Magazine Cover
③	Piston	⑪	Lock Lever
④	Driver Blade	⑫	Stop Lever
⑤	Body	⑬	Hook
⑥	Nose	⑭	Air Plug
⑦	Outlet	⑮	Double Trigger
⑧	Trigger	⑯	Valve

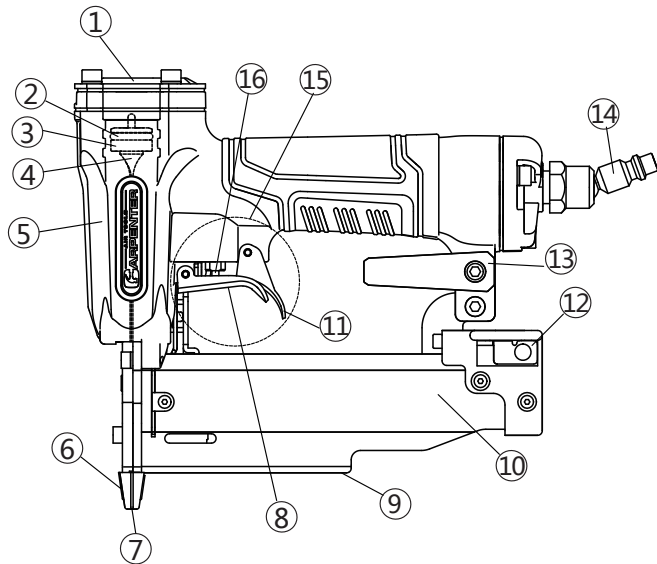

COMPATIBLE COMPRESSORS

GUIDELINES FOR PROPER USE AND OPERATION

Be sure to use a proper air compressor with CARPENTER Air Tools. The compressor should be able to supply a minimal air delivery of 4.1 CFM @ 90 PSI to ensure the compressor can run continuously with the CARPENTER Pin Nailer.

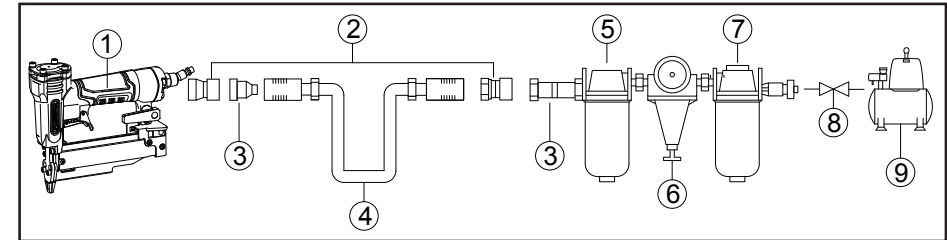

No.	Description	No.	Description
1	Pin Nailer	6	Regulator
2	Quick connector	7	Filter
3	Quick coupler	8	Cut-off valve
4	Air hose	9	Air compressor
5	Lubricator		

- It is recommended that a filter-regulator-lubricator be used and be located as close to the tool
- If a filter-regulator-lubricator is not installed, place up to 6 drops of compressor oil into the air inlet plug before each use.
- If a filter-regulator-lubricator is installed, keep the air filter clean. A dirty filter will reduce the air pressure to the tool, which will cause a reduction in power, efficiency, and general
- Verify that all of the connections in the air supply system are sealed in order to prevent air leakage.

Read and follow all the safety instructions at the beginning of this manual and inspect the air-powered nailer prior to each use in order to ensure that the proper power source is being used and verify that the tool is in proper working order

ACCEPTABLE NAILS

Carpenter Pin Nailer 5/8"--1-3/8"nails as following pic.

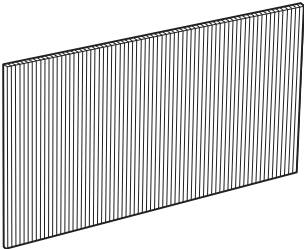
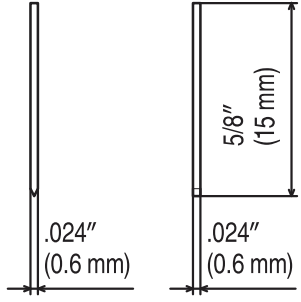
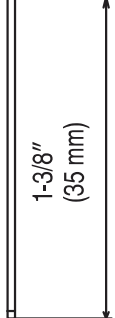
23 Gauge pin nails	Min.	Max.
		

LOADING NAILS

1. Pull the stop lever, open the magazine cover as attached picture position (Fig.A).

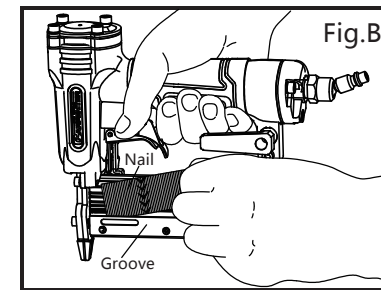
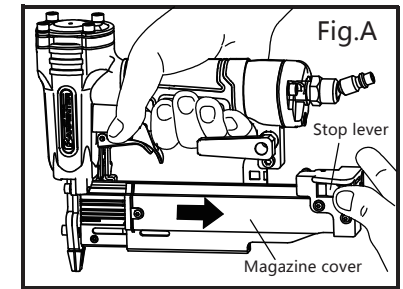

2. Put the pin nails into the groove as the following pic (Fig.B).

3. Push the pin nails into the blade guide and close the magazine (Fig.C).

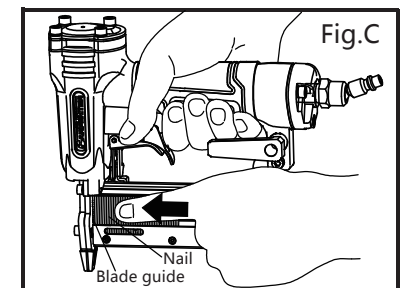

METHODS OF OPERATION

1. Put the nose on the working surface
2. Put the finger on the Double trigger
3. Press the trigger

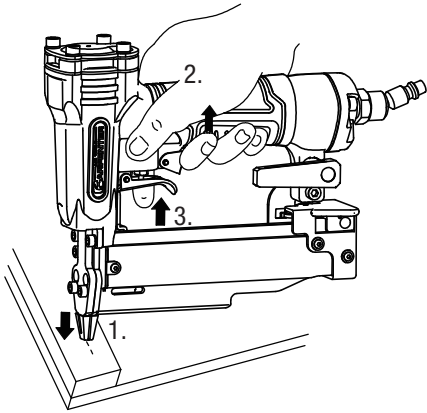

ADJUSTING THE NAILING DEPTH

1. Connect to the air hose.
2. Insert nails into the magazine.
3. Setting the working pressure in the range of 70-100psi.
4. Fire the nail into the working surface.
5. Check the nail depth, if it is too shallow, increase the working pressure, if it is too deep, decrease the working pressure.
6. Rework Step 4-5, until the nail depth is normal.

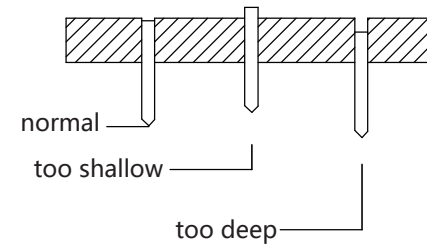

DANGER!

- Do not drive nails on top of other nails or with nailer at too steep an angle. Nails can ricochet and seriously injure someone.
- Do not drive nails from both sides of a wall at the same time. Nails can be driven into and through the wall and hit a person on the opposite side.
- Never drive nails into thin boards or near corners and edges of workpiece. Nails can be driven through or away from workpiece resulting in serious or life threatening injury.
- Never use a nailer which is defective or operating abnormally.
- Never use a nailer as hammer.

CLEARING A JAMMED NAIL

1. Disconnect air hose.
2. Remove the nose cap
3. Disassemble the two hexagon screws
4. Remove the cover plate and remove the pins
5. Assembly the cover plate and tighten the screws
6. Assembly the nose cap

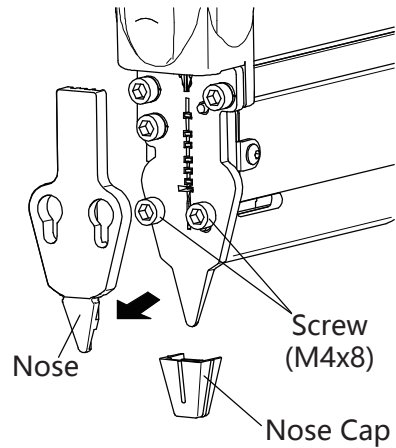

MAINTENANCE

MAINTENANCE REQUIRED	DESCRIPTION	TOOLS OR MATERIALS REQUIRED	MAXIMUM SERVICE INTERVAL		
			Each Use or Every 2 Hrs	Monthly	As Needed
General inspection-free movement	Trigger, spring, safety mechanism	None	X		
In-depth inspection	Worn or broken parts			X	X
Replace worn or broken parts					X
Lubrication	See below	Pneumatic tool oil	X		

- Lubrication: If the air-powered pin nailer and the compressor are not equipped with an in-line lubrication system, place up to 2 drops of pneumatic tool oil into the air inlet before each work day or after every 2 hours of continuous use, depending on the characteristics of the workpiece and type of fasteners used.

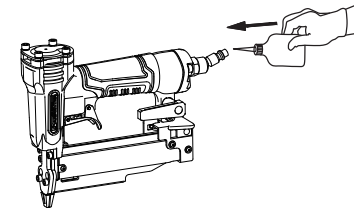

- Air-operated tools must be inspected periodically and worn or broken parts must be replaced to ensure that the tools are operating safely and efficiently.
- Inspect and replace worn or damaged O-rings, seals, etc. Tighten all screws and caps frequently in order to help prevent personal injury.
- Keep the magazine of the tool clean and free of any dirt or abrasive particles.

TROUBLESHOOTING

The following chart lists common issues and solutions. Please read it carefully and follow all instructions carefully. Disconnect the tool from the air supply before making any adjustments.

BASIC MAINTENANCE	POSSIBLE CAUSES	SOLUTIONS
Drain air line filter daily.	Prevent accumulation of moisture and dirt.	Open manual petcock.
Keep lubricator filled.	Keep the Nailer lubricated.	Fill with Carpenter tool lubricant.
Clean filter element — then blow air through filter in direction opposite to normal flow.	Prevent clogging of filter with dirt.	Follow manufacturer's instructions.
Clean magazine and feeder mechanism.	Prevent a jam.	Blow clean daily.
Keep push lever working properly.	Promote operator safety and efficient Nailer operation.	Blow clean daily.
Lubricate the Nailer after nailing.	Extend the Nailer life.	Supply 5 – 10 drops of lubricant into the Nailer.
Drain air compressor.	Keep the Nailer operated properly.	Open petcock on air compressor tank.

BASIC MAINTENANCE	POSSIBLE CAUSES	SOLUTIONS
Nailer operates, but no nail is driven.	Check for a jam. Nail feeder damaged? Pushing spring weakened or damaged? Check for proper nails.	Clear a jam page 14. Replace nail feeder. Replace Pushing spring. Use only recommended nails.
Weak drive. Slow to cycle.	Check air pressure. Driver blade worn? Piston O-ring worn or damaged?	Increase air pressure. (Do not exceed 100 psi (6.9 bar 7.0 kgf/cm ²)) Contact Carpenter for replacement.
Drives too deep.	Check air pressure.	Reduce air pressure. (Adjust 70 – 100 psi (4.8–6.9bar 4.9–7.0 kgf/cm ²))
Skipping nails. Intermittent feed.	Check for proper nails. Nail feeder damaged? Pushing spring weakened or damaged? Piston O-ring worn or damaged?	Use only recommended nails. Replace nail feeder. Replace Pushing spring. Contact Carpenter for replacement.
Nails jam. Driven nail is bent.	Check for proper nails. Driver blade worn?	Use only recommended nails. Contact Carpenter for replacement.
Drives properly during normal operation, but does not drive fully at faster nailing speeds.	Check inside diameter of air hose.	Use larger air hose.

TROUBLESHOOTING

TROUBLESHOOTING

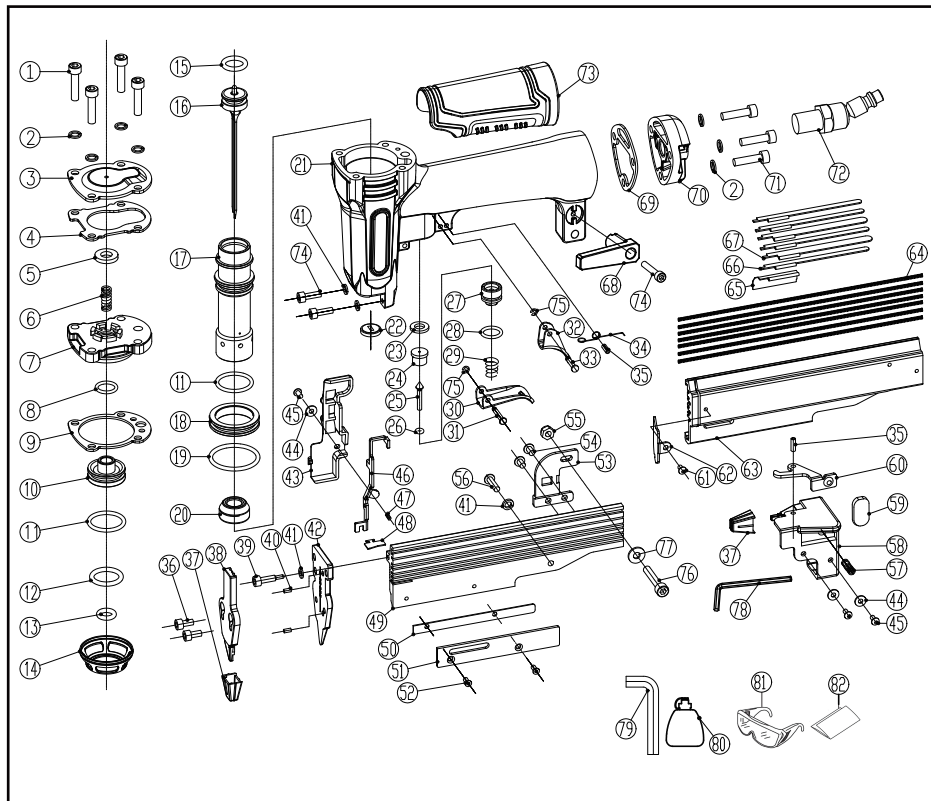

No.	Description	Qty.
1	Hex bolt M5X22	5
2	Washer 5	7
3	Air exhauster	1
4	Washer	1
5	Washer	1
6	Spring	1
7	Cylinder head cap	1
8	O-ring 11.7X2	1
9	Washer	1
10	Switch valve	1
11	O-ring 21.8X2.5	1
12	O-ring 17.2X3	1
13	O-ring 7.6X3	1
14	Support collar upper	1
15	O-ring 12.2X3	1
16	Main piston	1
17	Cylinder	1
18	Support collar lower	1
19	O-ring 30.2X2.65	1
20	Bumper	1
21	Tool body	1
22	Rubber pad	1
23	Sealing washer 12.9x7x1.8	1
24	Valve bushing	1
25	Vale rop	1
26	O-ring 1.7X2	1
27	Sleeve	1
28	O-ring 11.2X2	1
29	Trigger spring	1
30	Trigger I	1
31	Trigger pin 15X3	1
32	Trigger II	1
33	Trigger pin II 11.3X3	1
34	Spring	1
35	Roll pin 3X8	2
36	Hex bolt M4X8	2
37	Muzzle	2
38	guider	1
39	nut	1
40	Roll pin 2.5X5	2
41	Washer 4	4

No.	Description	Qty.
42	Head	1
43	cover	1
44	Washer d=3	3
45	Hex bolt M3X6	3
46	Holder	1
47	Spring	1
48	Top flat	1
49	Fixed magazine	1
50	Article guide pin	1
51	Pintle plate	1
52	Hex bolt M3X6	2
53	Fixed seat	1
54	Hex bolt M4X6	2
55	Hex bolt M5	1
56	Hex bolt M4X10	1
57	Spring	1
58	Retainer	1
59	Protective pad	1
60	Bolt lever	1
61	Hex bolt M3X5	1
62	Limit piece	1
63	Magazine	1
64	Spring	7
65	Top A	1
66	Top B	4
67	Top C	2
68	Hook	1
69	Washer	1
70	End cover	1
71	Hex bolt M5X20	3
72	1/4 NPT air connector	1
73	Handle sleeve	1
74	Hex bolt M4X12	3
75	Split washer 2.5	2
76	Hex bolt M5X25	1
77	Washer d=5	1
78	Allen wrench M4	1
79	Allen wrench M5	1
80	Lubricant oiler	1
81	Eye protection	1
82	Manual	1