

CARPENTER AIR TOOLS

3-in-1 16 Gauge Flooring Nailer & 15.5 Gauge Flooring Stapler



Model No. CFL5016

IMPORTANT:

Please read this manual carefully before using this product, and save it for reference.

**INSTRUCTION
MANUAL**

TABLE OF CONTENTS

TECHNICAL SPECIFICATIONS	4
SAFETY GUIDELINES	5
KEY PARTS DIAGRAM	8
TECHNICAL INFORMATION	9
TYPES OF NAILS	10
OPERATING INSTRUCTIONS	11
MAINTENANCE	15
TROUBLESHOOTING	16
EXPLODED VIEW	18
PARTS LIST	19

TECHNICAL SPECIFICATIONS

NET WEIGHT	12.8lbs /5.8 kg
SHIPPING WEIGHT	15.2 lbs /6.9 kg
DIMENSIONS	21-1/2" (H) x 3-9/16" (W) x 19-1/8" (L) (546x91x486mm)
LOADING CAPACITY	90 staples: 110 T & L cleats
OPERATING PRESSURE	70-115psi (4.8-7.9bar)
FASTENER DETAILS	Drives 1-1/2" to 2" 15.5 Gauge Staples and 16 Gauge T&L Flooring Cleats
DRIVING POWER	420 in./lbs
AIR CONSUMPTION	0.033ft ³ (1.5lit)/cycle at 90 psi (6kg/cm ²)
APPLICATIONS	3/4", 5/8" & 1/2" Tongue & Groove Solidwood flooring

CFM: Cubic feet per minute refers to the volumetric flow of air. This information is used to determine the proper compressor to suit your needs.
NPT: National Pipe Thread.

SAFETY GUIDELINES

This manual contains information that relates to PROTECTING PERSONAL SAFETY and PREVENTING EQUIPMENT PROBLEMS. It is very important to read this manual carefully and understand it thoroughly before using the product. The symbols listed below are used to indicate this information.



DANGER!

Potential hazard that could result in serious personal injury including possible death.



WARNING!

Potential hazard that could result in serious personal injury to the tool user or others in the work area.



CAUTION!

Potential hazard that could result in damage to the tool or property.

PERSONAL SAFETY

These precautions are intended for the personal safety of the user and others working with the user. Please take time to read and understand them.
Make sure you read and understand this manual before using this tool. Make sure other users read and understand this manual before they use the tool.

SAFETY GUIDELINES

- DANGER! Potential hazard that could result in serious personal injury including possible death.
- Do not use oxygen or any other combustible or bottled gas to power air-powered tools. Failure to observe this warning can cause explosion and serious personal injury or death.

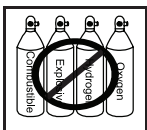

- Do not use this tool in the presence of flammable liquids, dust or gases. Sparks that are created during use may ignite these materials.
- Use only compressed air to power air-powered tools. Use an approved air hose with a minimum length of 25' (7.6 m).
- Do not allow inexperienced or untrained individuals to operate any air-powered tool.
- Keep hands and other parts of the body away from the Outlet (Firing Head) during use.
- Nails or objects in the workpiece can cause serious injury if they are deflected by the workpiece.
- Keep children away from the work area. Do not allow children to handle power tools.
- Never point nailer toward yourself or anyone else.
- Always assume the nailer contains fasteners. Never point the nailer toward yourself or anyone else, whether it contains fasteners or not. If fasteners are mistakenly driven, it can lead to severe injuries. Never engage in horseplay with the nailer. Respect the nailer as a dangerous working implement.

WARNING!

Potential hazard that could result in serious personal injury to the tool user or others in the work area.

- Always wear eye and hearing protection when using the air compressor. Failure to do so may result in sight or hearing loss.
- Do not overload the tool. Allow the tool to operate at its optimum speed for maximum efficiency.
- Do not point the tool towards yourself or other people, even when the tool has stopped. Keep hands, feet, and all other parts of the body clear from work area.
- Do not attempt to clear nailer jams while the air hose is connected.
- Do not keep the trigger or the Push Lever pressed while loading nails.



CAUTION!

Potential hazard that could result in damage to the tool or property.

- Disconnect the tool from the air supply and turn off the compressor before performing any maintenance. When the tool is not in use, when it is being handed to another person, when it is left unattended, or when loading and changing nails. Failure to comply may result in injury or damage to equipment.

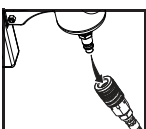

- Do not exceed the maximum or minimum pressures. Operating the tool at the wrong pressure (too low or too high) will cause excessive noise or rapid wear.
- Use only Non-Detergent Air Tool Lubricating Oil for this tool.
- Near and below freezing, moisture in the air line may freeze and prevent tool operation. Do not store in a cold weather environment to prevent frost or ice formation. Frost and ice on the tools operating valves and mechanisms could cause tool failure.

NOTE: Some commercial air line drying liquids are harmful to "O" rings and seals—Do not use these low temperature air dryers without checking compatibility.

KEY PARTS DIAGRAM

No.	Description	No.	Description
1	Magazine	4	Air inlet plug
2	Spacer base plate for depth control	5	Magazine pusher latch
3	Rubber Actuator		

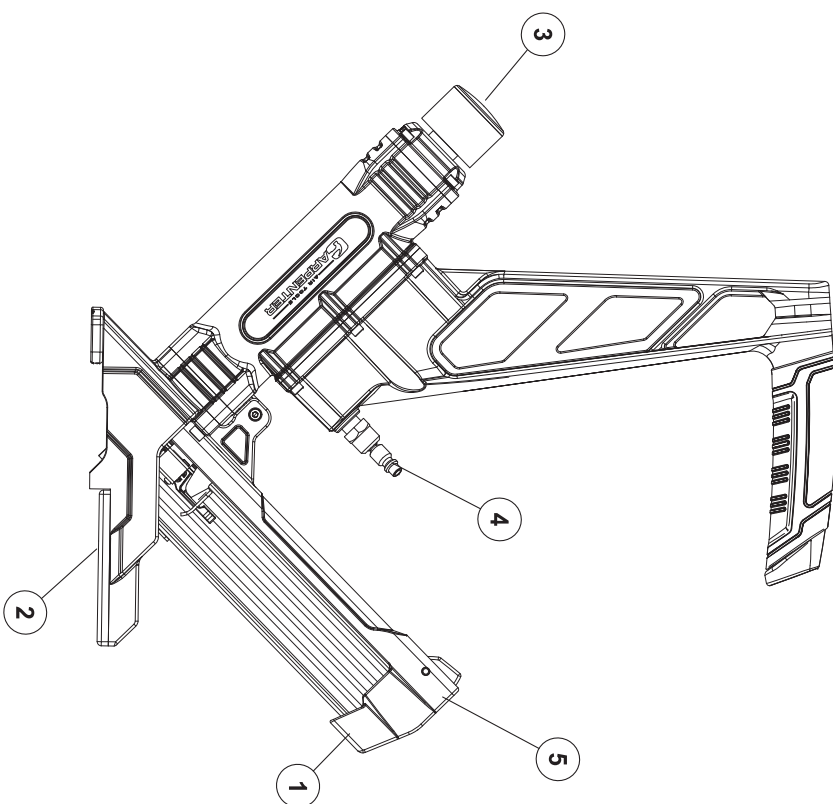

General use

This Carpenter Air-powered 3-in-1 Flooring Nailer drives 15.5 GAUGE staples 1 1/2 to 2" (38 to 50 mm) long with a 1/2" (12.7 mm) crown, and "L&T" shaped cleats and nails that are between 1 1/2 and 2" (38 and 50 mm) in length. It features a heat treated die-cast aluminum housing and a comfortable handle for optimal control and comfort, even during extended use. It is well balanced for stability, and ergonomically designed with a longer handle for ease of operation. It also features a hardened driver blade for longer life, a composite base plate to eliminate scratches and damage to surfaces, and economical air consumption with low noise. This Air-powered 3-in-1 Flooring Nailer is specifically designed for installing hardwood flooring.

Compatible compressors

GUIDELINES FOR PROPER USE AND OPERATION
Be sure to use a proper air compressor with Carpenter Air-powered tools. The compressor should be able to supply a minimal air delivery of 6.36 CFM @ 90 PSI to ensure the compressor can run continuously with the Carpenter Air-powered 3-in-1 Flooring Nailer.

Air system

- Always use clean, dry, regulated, compressed air at 70 to 115 PSI (4.8 to 7.9 bar).
- Do not exceed maximum or minimum pressures. Operating the tool at the wrong pressure (too low or too high) could cause excessive noise or rapid wear of tool.

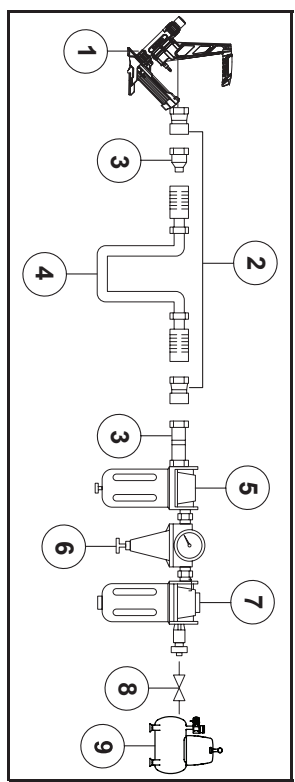

No.	Description	No.	Description
1	Air-powered 3-in-1 Flooring Nailer	6	Regulator
2	Quick connector	7	Filter
3	Quick coupler	8	Cut-off valve
4	Air hose	9	Air compressor
5	Lubricator		

This Air-powered 3-in-1 Flooring Nailer accepts the following size and type of fasteners.

ACCEPTABLE FASTENERS

Flooring staples (15.5 gauge)

Grown: 1/2" (12.7 mm)
Length: 1-1/2" to 2" (38-50mm)

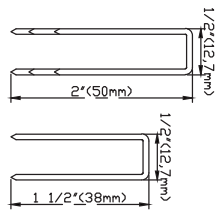

T-Shaped cleats/nails (16 gauge)

Length: 1-1/2" to 2" (38-50mm)

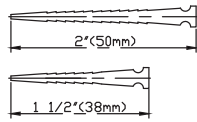

L-Shaped cleats/nails (16 gauge)

Length: 1-1/2" to 2" (38-50mm)

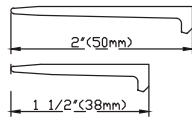

Loading fasteners

1. Disconnect the tool (1) from the air supply (2) (Fig. A).

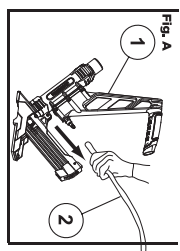

2. Take hold of the Air-powered 3-in-1 Flooring Nailer firmly with one hand. Use the other hand to press the pusher latch (1) on the magazine and slide it back. Make sure you have the right nails for your tool (See page 10). Insert a strip of fasteners (2) into the magazine. Ensure that the points of the fasteners are facing down (Fig. B).

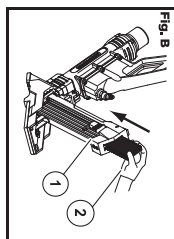

3. Release the Pusher (Fig. C-1) until it closes the magazine resting against the fasteners (Fig. C-2).

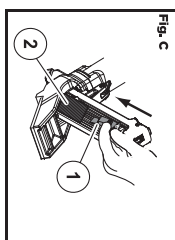

4. Plug in compressor, turn it on, set the pressure regulator to 90 PSI, and attach one end of the air hose to the compressor and the other end of the air hose (1) to the tool (2). Use plumber's tape to avoid air leaks (Fig. D).

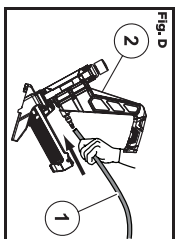

OPERATING INSTRUCTIONS

5. Hold the handle and lift the 3-in-1 Flooring Nailer into place. Strike the Rubber Actuator with the Rubber side of the Mallet to drive a nail (Fig. E).

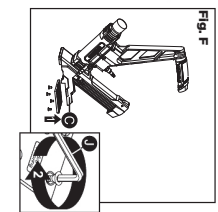
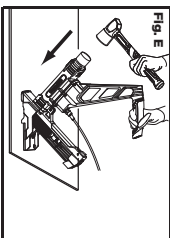

6. Using the hex key (J), hold the nailer upside down and remove the four screws from the base plate by turning counter clockwise. Attach the desired plate (See Fig. F). Ensure the screw holes on the base plate line up with the holes at the nailer base (C). Tighten the screws by turning clockwise (See Fig. F). Make sure screws do not protrude out of the base plate.

INSERTION METHODS

The Air-powered 3-in-1 Flooring "L&T" cleats and staples, which are to be inserted using different insertion methods.

1. "L&T" cleats: Insert the cleats (1) from the top area of magazine into the centre slot at the top of the magazine (Fig. G).

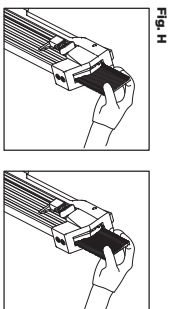
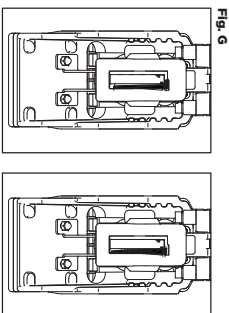

2. Staples: Insert the staples (1) from the top area of the magazine with one arm of the staple in the center slot of the magazine and the other arm along the left side of the magazine (Fig. H).

Clearing a jammed fastener

To clear a jammed fastener:

- Disconnect the tool from the air supply line.
- Remove the fasteners that are stored in the tool's magazine.
- Use pliers or any appropriate tool to remove the jammed fastener.
- Reload the fasteners into the tool magazine.
- Reconnect the air line to the tool's air inlet.
- Test fire 3 to 5 fasteners into a piece of scrap wood in order to ensure proper operation.

1. Pull the pusher latch to the end of the magazine to lock it (Fig. I).

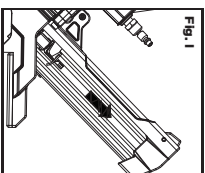

DANGER!

Potential hazard that will result in serious injury or loss of life.

- Do not operate the tool if the fasteners are not loaded, doing so may damage the tool.
- Do not fire fasteners into the air, doing so may cause injury to the operators or others, apart from damaging the tool.
- Load the correct type of fasteners only, do not load different sized fasteners into the magazine, doing so may cause fasteners to jam. Failure to comply will lead to serious injury or loss of life.
- The nailer releases one fastener with each hit, so hitting the whack cap twice will project a second fastener onto the first one which could cause a potential ricochet hazard.
- Ensure that the hammer exerts sufficient amount of force on the nailer. If the force is too low, the fastener will not be inserted completely onto the flooring. For nails that are not completely inserted, use a hammer to pull out the nails or knock the nails in with a nail setter. Do not attempt to drive a fastener into the same location twice.

NOTE:

Test the driving depth using a scrap piece of wood before working on the workpiece. If the fasteners are being driven too deep or not deeply enough, adjust the air pressure in order to provide more or less air pressure, as required.

OPERATING INSTRUCTIONS

OPERATING INSTRUCTIONS

2. Using the hex key, hold the gun upside down and loosen the four screws from the cover plate by turning counter clockwise (Fig. J).

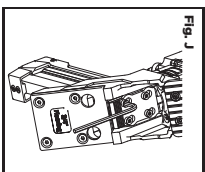

3. Pull out and lift up the cover plate. Remove it to clean the jam (Fig. K & L).

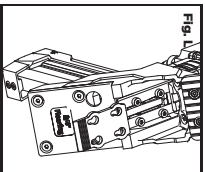
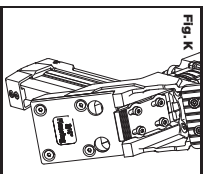

Storage
If it is necessary to store the tool for an extended period of time, apply a generous amount of lubrication before storing. The tool should be allowed to run for approximately 30 seconds after lubricating, in order to ensure that the lubrication is uniformly distributed throughout the tool.

Maintenance

MAINTENANCE REQUIRED	DESCRIPTION	TOOLS OR MATERIALS REQUIRED	MAXIMUM SERVICE INTERVAL	
			Each use or every 2 hrs	Monthly As needed
In-depth inspection	Worn or broken parts			X
Replace worn or broken parts				X
Lubrication	See below	Pneumatic tool oil	X	

- **Lubrication:** If the Air-powered 3-in-1 Flooring Nailer and the compressor are not equipped with an in-line lubrication system, place up to 6 drops of pneumatic tool oil into the air inlet before each work day or after every 2 hours of continuous use, depending on the characteristics of the workpiece and type of fasteners used.

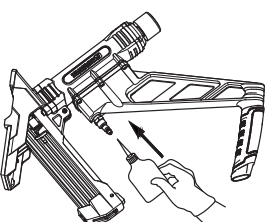

- Air-operated tools must be inspected periodically and worn or broken parts must be replaced to ensure that the tools are operating safely and efficiently.
- Inspect and replace worn or damaged O-rings, seals, etc. Tighten all screws and caps frequently in order to help prevent personal injury.
- Keep the magazine of the tool clean and free of any dirt or abrasive particles.

Troubleshooting

The following chart lists common operating system issues and solutions.

Please read it carefully and follow all instructions carefully.

- Disconnect the tool from the air supply before making any adjustments.

- Repairs and replacement must be performed only by a qualified service technician or in an authorized service centre.

PROBLEM	POSSIBLE CAUSES	SOLUTIONS
Air leakage near the bottom of the tool	<ol style="list-style-type: none"> 1. Screws are loose. 2. The O-rings or the bumper is/are damaged. 	<p>Contact a qualified service technician</p> <ol style="list-style-type: none"> 1. To tighten the screws. 2. To inspect and replace the O-rings or seals.
Air leakage between the body and the cylinder cap	<ol style="list-style-type: none"> 1. The screws are loose. 2. The O-rings or the seals are worn or damaged. 	<ol style="list-style-type: none"> 1. Tighten the screws. 2. Inspect and replace the O-rings or the seals. Have the tool serviced by a qualified service technician.
The fasteners are being driven too deep.	<ol style="list-style-type: none"> 1. The bumper is worn. 2. The air pressure is too high. 	<ol style="list-style-type: none"> 1. Replace the bumper. 2. Adjust the air pressure. Have the tool serviced by a qualified service technician.

PROBLEM	POSSIBLE CAUSES	SOLUTIONS
The tool does not operate properly - it does not drive the fasteners or operates sluggishly.	<ol style="list-style-type: none"> 1. The air supply is inadequate. 2. Lubrication is inadequate. 3. The O-rings or seals are worn or damaged. 4. The exhaust port in the cylinder head is blocked. 	<ol style="list-style-type: none"> 1. Verify that the air supply is adequate. 2. Pour up to 6 drops of oil into the air inlet. 3. Inspect and replace O-rings or seals. Have the tool serviced by a qualified service technician. 4. Replace the damaged internal parts. Have the tool serviced by a qualified service technician.
The tool skips fasteners.	<ol style="list-style-type: none"> 1. The bumper is worn or the spring is damaged. 2. There is dirt in the front plate. 3. Fasteners cannot move freely in the magazine because of dirt or damage. 4. The O-ring on the piston is worn or dry or there is not enough lubrication. 5. The cylinder cover seal is leaking. 	<ol style="list-style-type: none"> 1. Replace the bumper or pusher spring. Have the tool serviced by a qualified service technician. 2. Clean the drive channel on the front plate. 3. Clean the magazine. 4. Replace the O-ring. Have the tool serviced by a qualified service technician. 5. Replace the sealing washer. Have the tool serviced by a qualified service technician.
The tool jams.	<ol style="list-style-type: none"> 1. Fasteners are incorrect or damaged. 2. The driver guide is damaged or worn. 3. The magazine screw is loose. 4. There is dirt in the magazine. 	<p>(See section "Cleaning a jammed fastener").</p> <ol style="list-style-type: none"> 1. Use the proper fasteners. 2. Inspect and replace the driver. 3. Tighten the magazine. 4. Clean the magazine.

EXPLODED VIEW

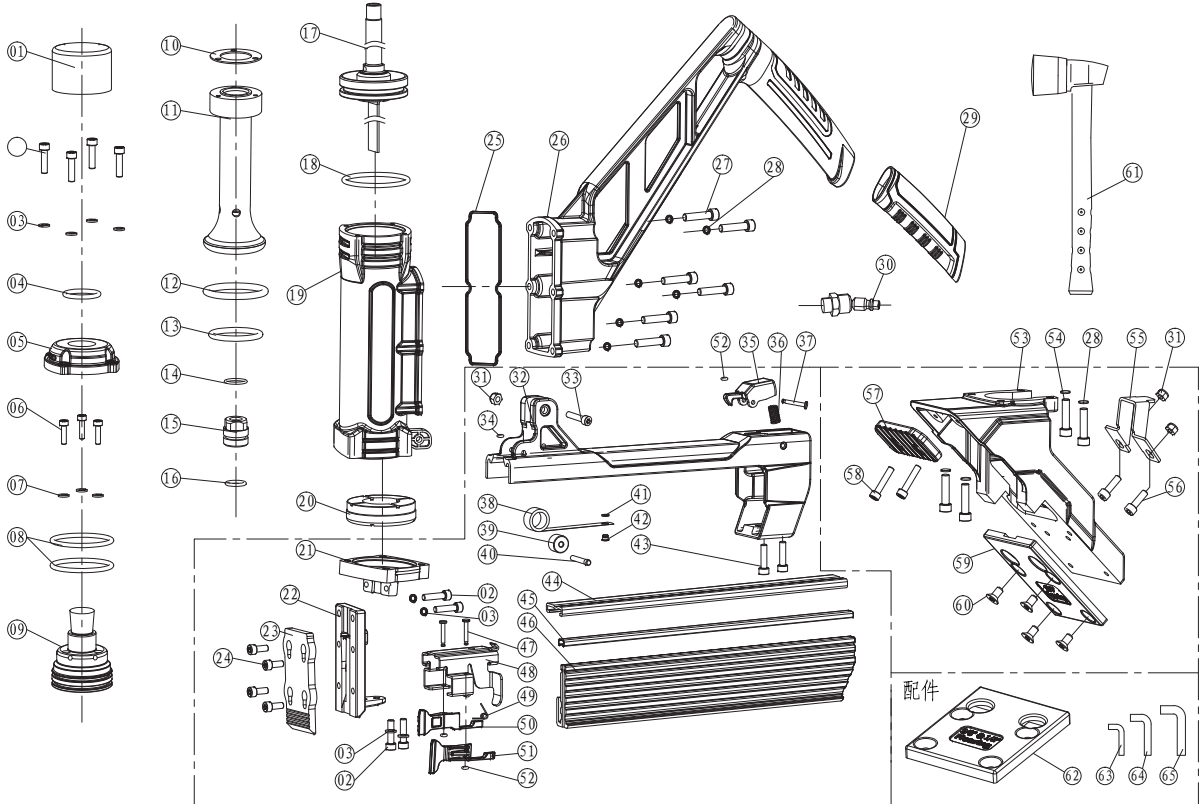

No.	Description	Qty.
-----	-------------	------

1	Whack cap	1
2	M5X20 screw	8
3	washers	8
4	"O" ring	1
5	Cylinder cover	1
6	MAX16 bolt	3
7	washers	3
8	"O" ring	2
9	piston seat	1
10	piston sleeve cover seal	1
11	piston sleeve	1
12	"O" ring (32X4.5)	1
13	"O" ring (12.4X2.5)	1
14	"O" ring (15.6X1.8)	1
15	nut	1
16	"O" ring (12.8X1.8)	1
17	Driver blade	1
	piston shaft	1
	washer	1
	piston	1
	piston pin	1
18	"O" ring (50X3.55)	1
19	Aluminum housing	1
20	Bumper	1
21	cylinder seat	1
22	driver guide plate	1
23	driver guide cover plate	1
24	M6X12 screws	4
25	handle gasket	1
26	Handle	1
27	M6X25 screws	6
28	washer	10
29	Hand grip	1
30	1/4 NPT 18 Air inlet plug	1
31	self locking nut	3
32	Magazine cover	1
33	M5X22 screws	1
34	"O" ring (1.7X2)	1

No.	Description	Qty.
-----	-------------	------

35	Magazine pusher latch	1
36	Magazine pusher latch spring	1
37	Magazine pusher latch pin	1
38	magazine coil spring	1
39	coil spring core	1
40	coil spring pin	1
41	coil spring seal	1
42	coil spring nut	1
43	M5X16 screws	2
44	pusher seat shelf	1
45	nail guide	1
46	Magazine	1
47	Pin	2
48	pusher seat	1
49	pusher spring	2
50	right pusher	1
51	left pusher	1
52	"O" ring	3
53	Base (shoe)	1
54	M6X40 screws	4
55	bracket	1
56	M5X14 screws	2
57	Front foot	1
58	M5X18 screws	2
59	3/4" base plate	1
60	M6X18 screws	4
61	Mallet	1
62	5/8" base plate	1
63	No.4 Hex Key	1
64	No.5 Hex Key	1
65	No.6 Hex Key	1
66	Oil	1
67	Manual	1

If any parts are missing or damaged, or if you have any questions, please call 1-888-666-1887.

PARTS LIST