

OWNER'S MANUAL



Smokin' Pro™ **Model # 1224**

Keep your receipt with this manual for Warranty.

CUSTOMER SERVICE
1-912-638-4724
Service@CharGriller.com

Contents of this manual are Trademarked and Copyrighted by Char-Griller | A&J Manufacturing. Using the information contained in this manual without consent of Char-Griller and/or A&J Manufacturing is strictly prohibited.

**No Returns
on Used Grills**

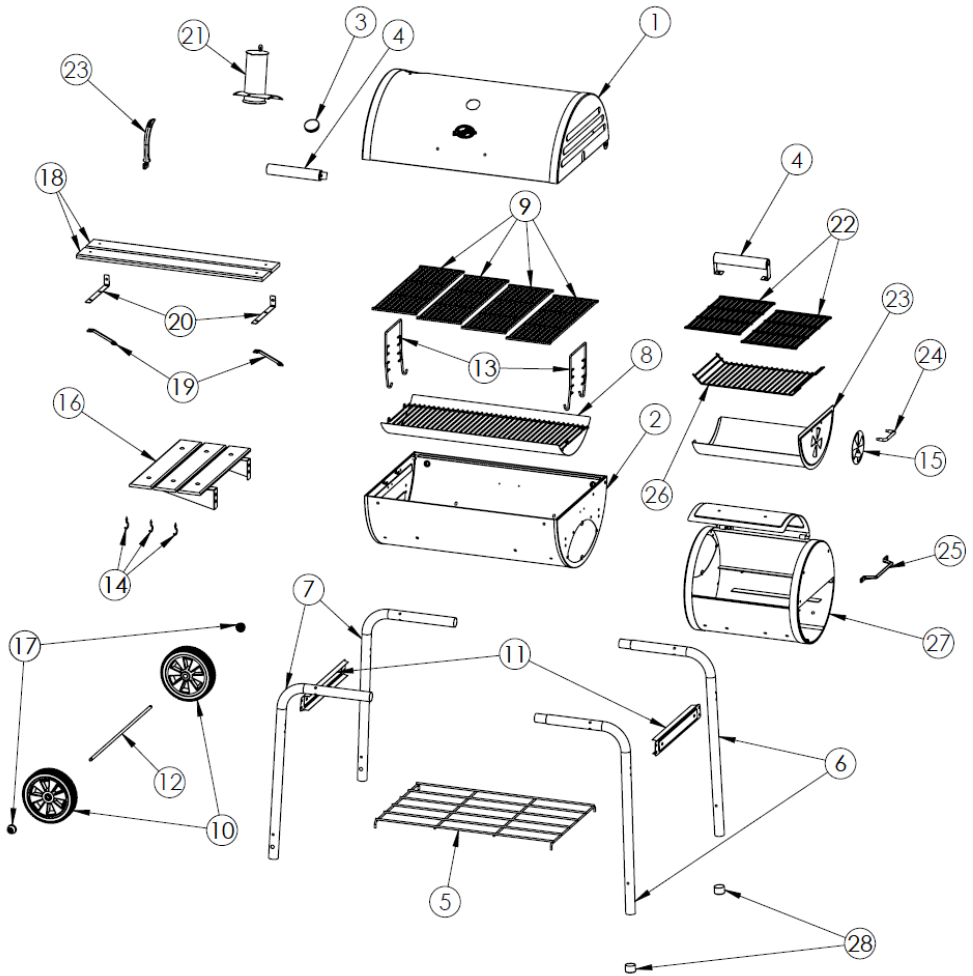

STOP! CALL  FIRST! DO NOT RETURN PRODUCT TO STORE.

CALL (912) 638-4724 This product has been built to the highest quality standards. Call us should you have any questions not addressed in these instructions, or for service information.

Have your grill serial number (located on the back of the grill body or on the leg) when calling.

Sold under license from W.C. Bradley Co.

PARTS LIST AND TOOLS REQUIRED

(Tools Not Included)

Pliers



and 7/16" nut driver



HARDWARE
USED
WITH YOUR
CHAR-GRILLER

Note: Hardware bag may contain extras.



Spring for Smokestack
2 pcs.

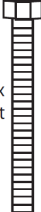

2" Hex Bolt
2 pcs.



1 3/4" Hex Bolt
12 Pcs.



Hair Cotter Pin
4 pcs.



1" Carriage Bolt
10 pcs.



Hinge Pin
2 pcs.



1/2" Self Tapping Screw
2 pcs.



1/2" Hex Bolt
15 pcs.



3/4" Hex Bolt
8 pcs.



"U" Handle Bolt
1 Pc.

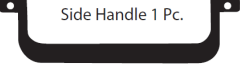

Side Handle 1 Pc.



Acorn Nut
1 for Smokestack Damper



Hex Nut 1/4"
49 pcs.



Lock Washer
9 pcs.



Spacer Tube
2 Pc.



Damper Circle (Not to scale) 1 pcs.



Push on Wheel Cap
2 Pcs. for Wheels

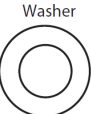

1/4" Washer
2 pcs.

LINE ITEM	QTY	DESCRIPTION	PART NO.
1	1	HOOD	20-0047
2	1	GRILL BODY	20.0049
3	1	HEAT GAUGE	55-0010
4	2	HOOD HANDLE	55-0014
5	1	WIRE SHELF	20-0050
6	2	LONG LEG	10-0055
7	2	SHORT LEG	10-0056
8	1	ASH PAN	20-0048
9	4	COOKING GRATE	10-0049
10	2	WHEEL	55-0003
11	2	LEG BRACE	10-0051
12	1	AXLE	10-0057
13	2	ASH PAN HANGERS	20-0024
14	3	UTENSIL HOOK	50-0003
15	1	DAMPER CIRCLE	10-0036
16	1	SIDE SHELF	30-0016
17	2	HUB CAP	55-0007
18	2	FRONT SHELF SLAT	10-0050
19	2	FRONT SHELF SUPPORTS	10-0053
20	2	FRONT SHELF BRACKETS	10-0052
21	1	SMOKESTACK	30-0015
22	2	SFB COOKING GRATES	10-0025
23	1	SFB DRAWER	20-0100
24	1	SFB DRAWER HANDLE	55-0015
25	1	SFB LARGE HANDLE	55-0016
26	1	FIRE GRATE	20-0028
27	1	SFB BODY	20-0101
28	2	LEG CAP	55-0013

PAGE INTENTIONALLY LEFT BLANK FOR NOTES

ASSEMBLY INSTRUCTIONS

Read all safety warnings and instructions carefully before assembling and operating your grill.

IMPORTANT HINT: DO NOT TIGHTEN ANY NUTS AND BOLTS UNTIL GRILL IS FULLY ASSEMBLED.

Step 1: Assemble Long Legs, Short Legs, and Leg Braces as show below then secure the Leg Braces to one set of Long Leg and Short Leg with four 1 3/4" Hex Bolts and four Hex Nuts.

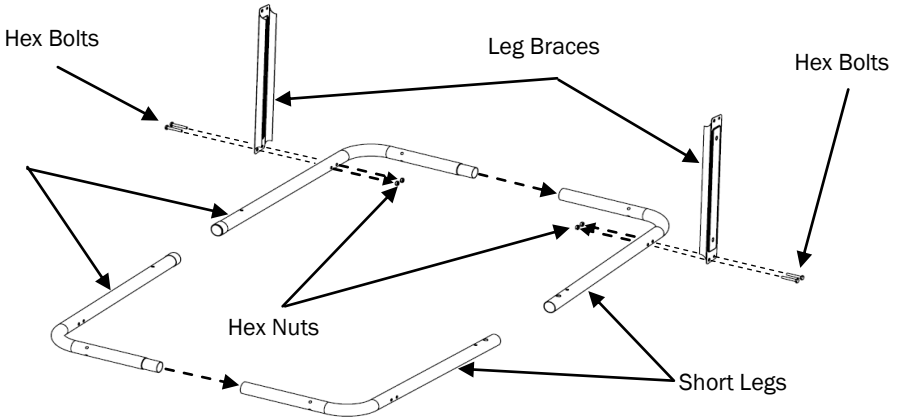

Step 2: Install Bottom Wire Shelf by placing the four corner hooks inside the hole on each leg then rotate the leg assemblies up and secure the Leg Braces to the other side of the Long Leg and Short Leg set.

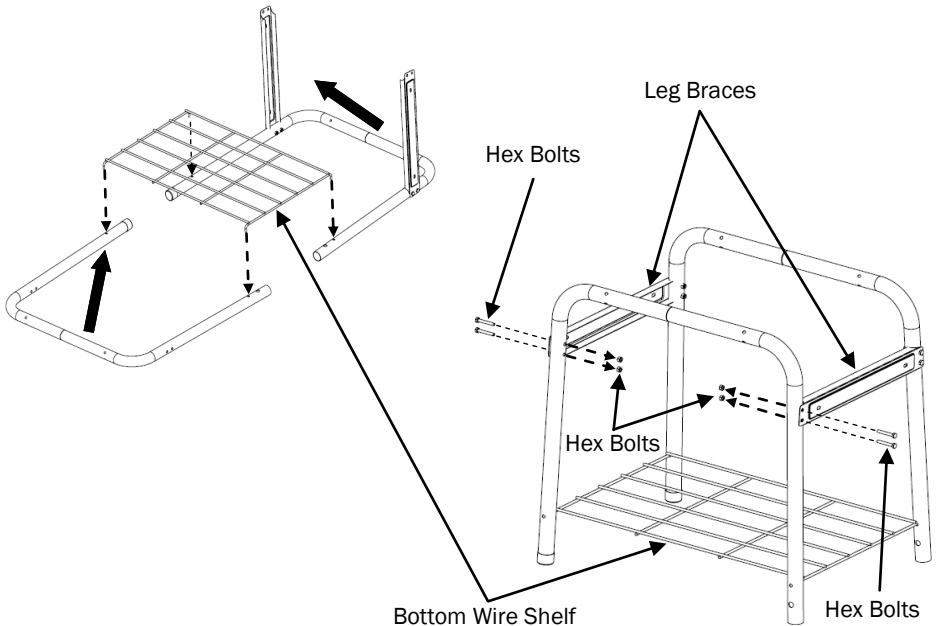

Step 3: Lay the cart assembly down with the Long Legs on the floor then install the Wheels and Wheel Axle. On one end of the Axle insert the Cotter Pin into the hole on the Axle and snap in the Hub Cap. Slide one Flat Washer and one Wheel onto the Axle then slide the Axle through the holes on the Short Legs and Bottom Shelf. Complete the assembly by sliding the other Wheel and Flat Washer onto Axle then insert the Cotter Pin and snap on the Hub Cap.

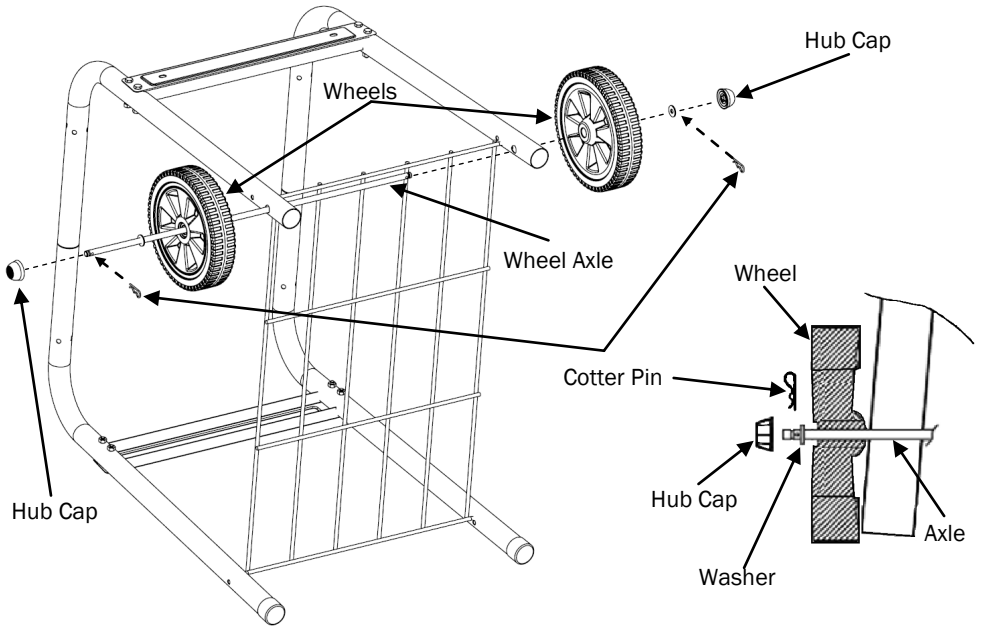

Step 4: Attach the Grill Body to the previous assembly cart using four 1 3/4" Hex Bolts and four Hex Nuts. The Bolts must go through the leg, Grill Body then tighten with the Hex Nuts inside the Grill body.

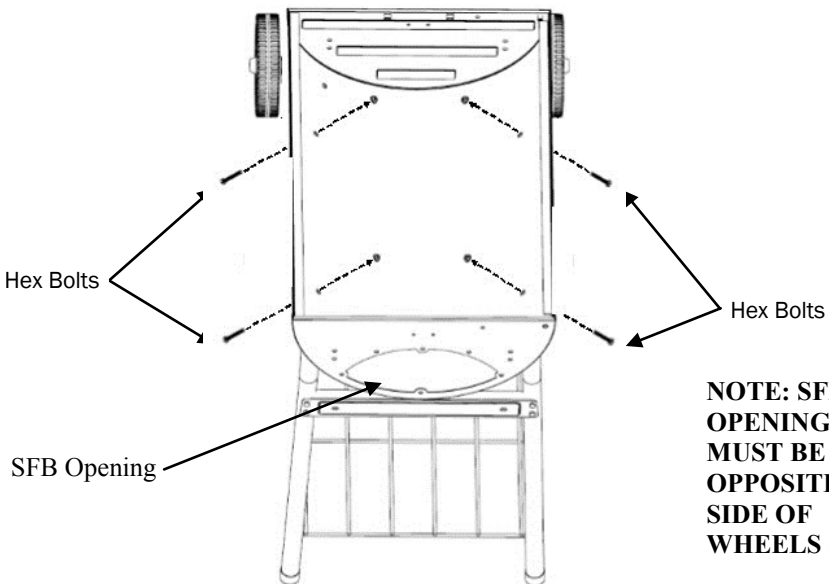

**NOTE: SFB
OPENING
MUST BE ON
OPPOSITE
SIDE OF
WHEELS SIDE.**

Step 5: Install SFB to the Grill Body using six 1/2" Hex Bolts, two 2" Hex Bolts, and eight Hex Nuts. Bolts should go through the holes from the inside of the SFB Body.

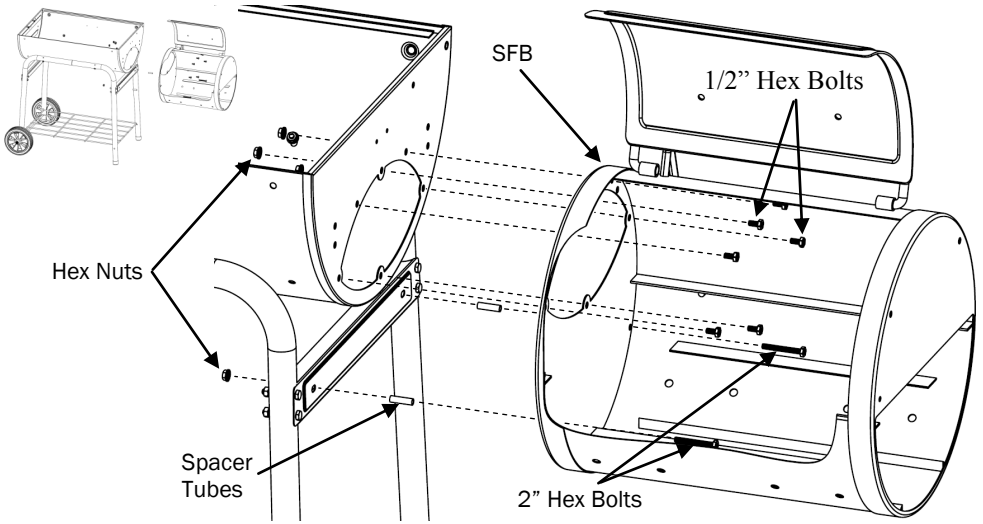

Step 6: Attach the Grill Hood to the Grill Body using the two Hinge Pins and two Cotter Pins provided.

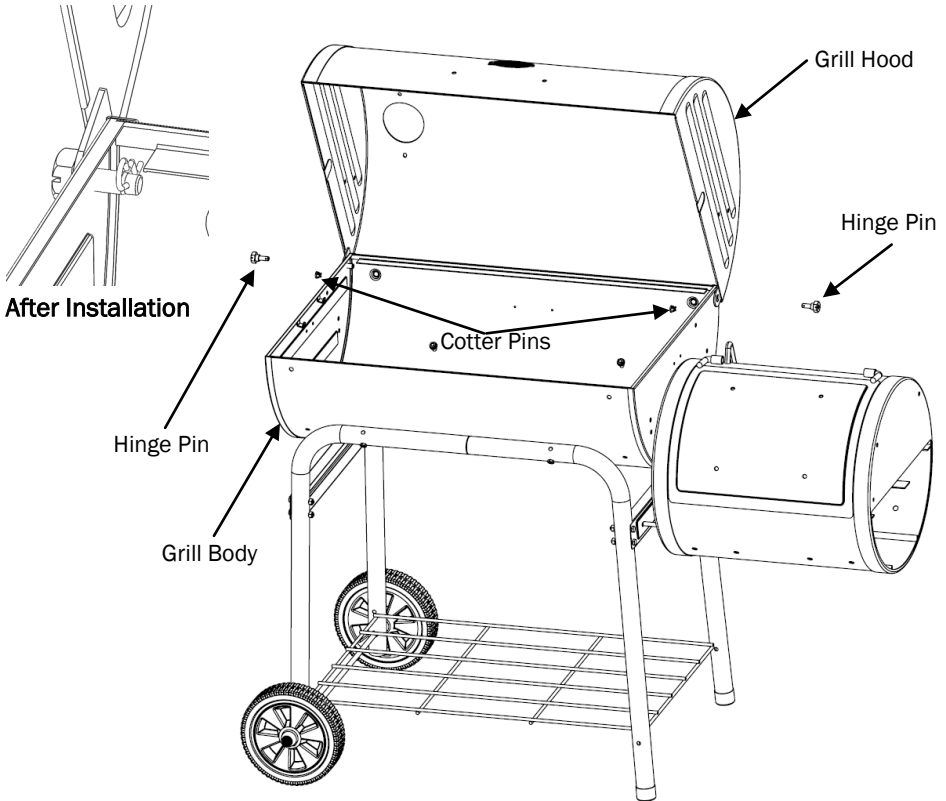

Step 7: Attach Side Shelf to Grill Body with four 1/2" Hex Bolts and four Hex Nuts.

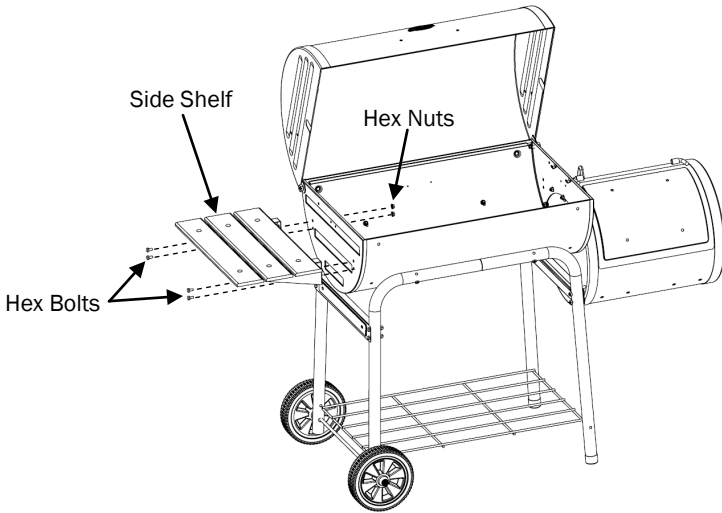

Step 8: Attach Front Shelf to Grill Body with four Hex Bolts and four Hex Nuts. First Assemble the side shelf using four 1" Carriage Bolts and four Hex Nuts.

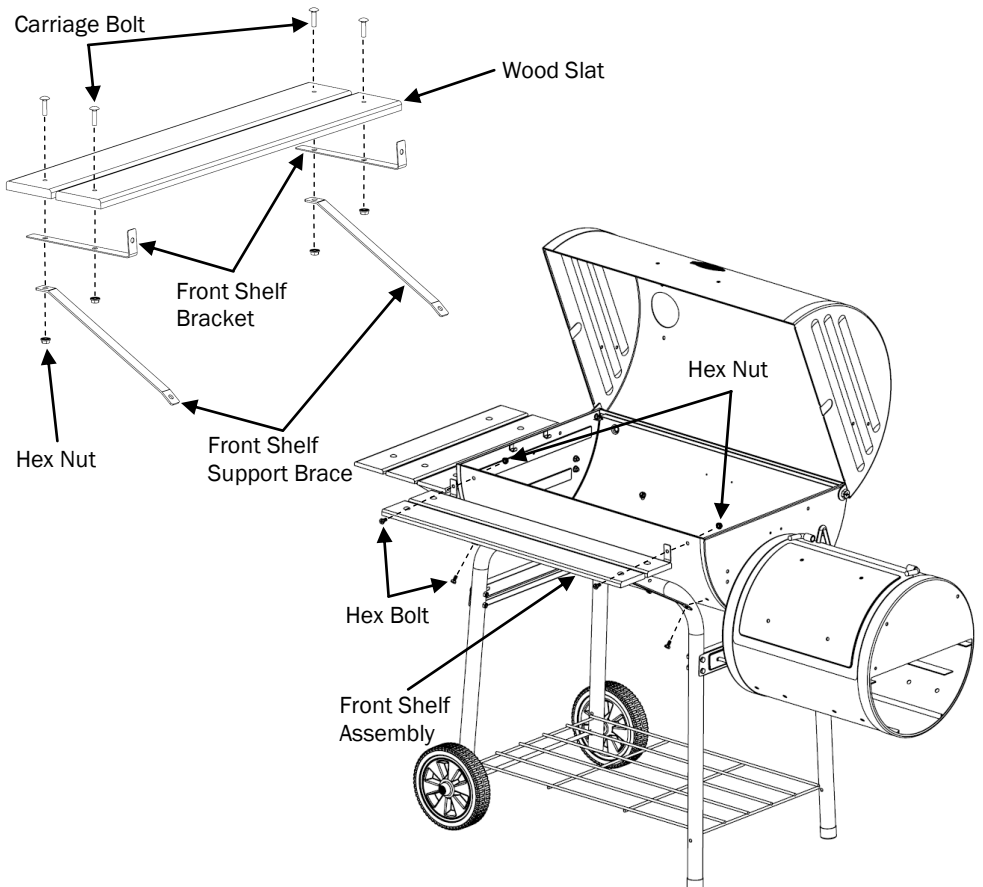

Step 9: Insert Smokestack Assembly through the hole on the Grill Hood from the inside of the Grill Hood then secure it with two Hex Bolts and two Hex Nuts.

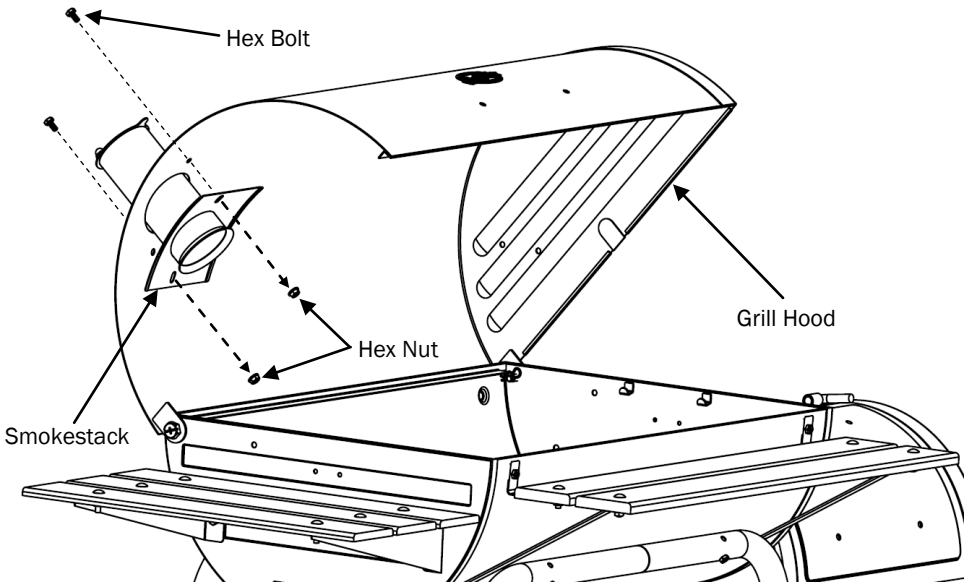

Step 10: Insert Heat Gauge through hole in Grill Hood (from outside) and push the Retainer Ring over tabs on the side of Heat Gauge from inside of the Grill Hood. Then attach Hood Handle to the Grill Hood with two 3/4" Hex Bolts, two Lock Washers, and two Hex Nuts. See below.

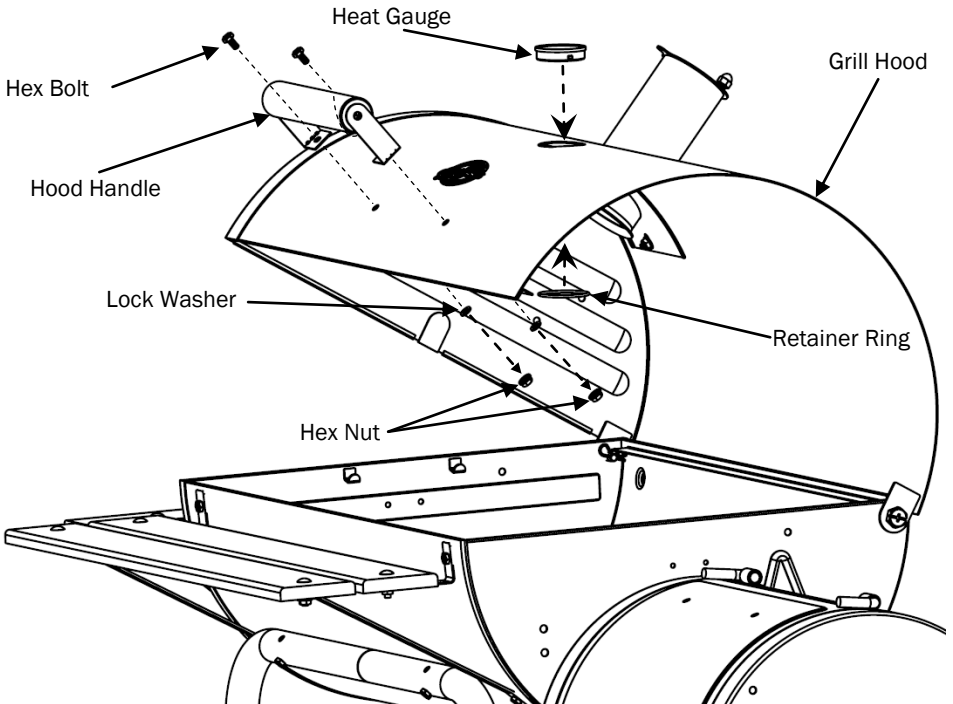

Step 11: Install SFB Handle using two 3/4" Hex Bolts and two Hex Nuts. Then install SFB side Handle using two 1/2" Hex Bolts and two Hex Nuts.

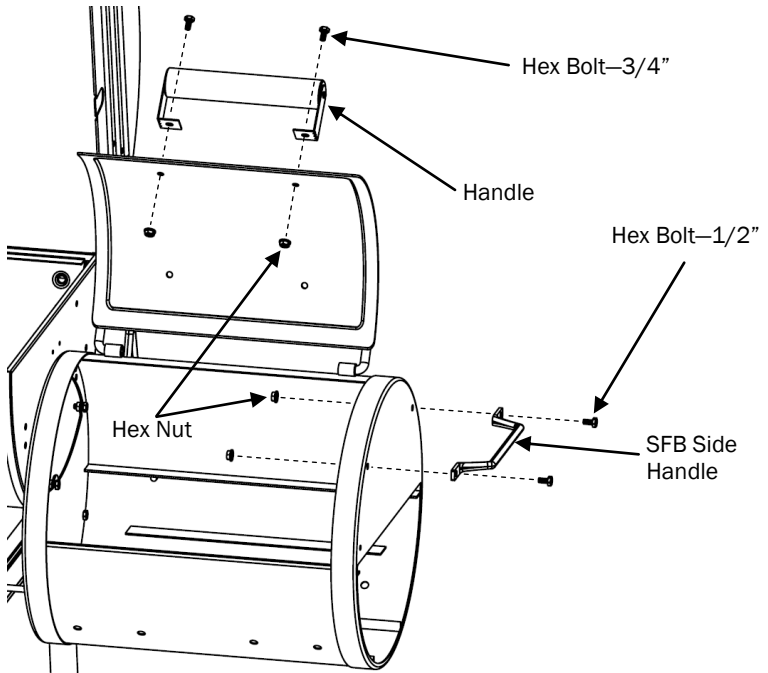

Step 12: Attach the Damper Circle to the inside of the Ash Drawer using one 1/2" Hex Bolt, two Flat Washers, one Lock Washer, and one Hex Nut. Attach the Drawer Handle to the Ash Drawer using two Hex Nuts. Then slide the Ash Drawer into the SFB.

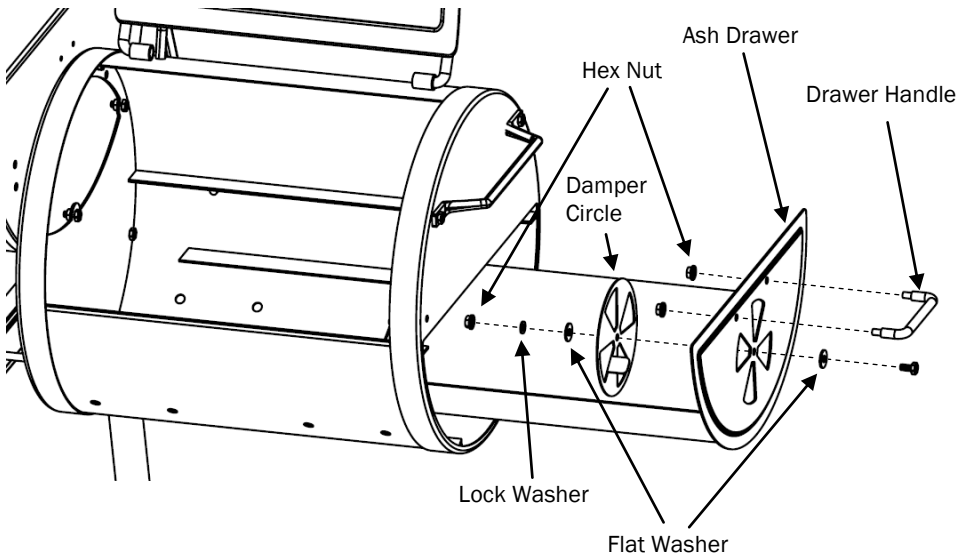

Step 13: Place Charcoal Grate and Cooking Grate onto the SFB Body.

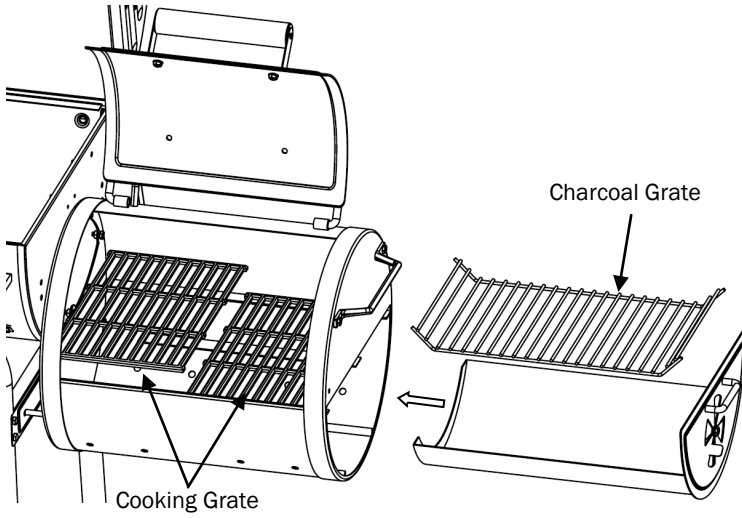

Step 14: Place Ash Pan and Ash Pan Hangers onto Grill Body.

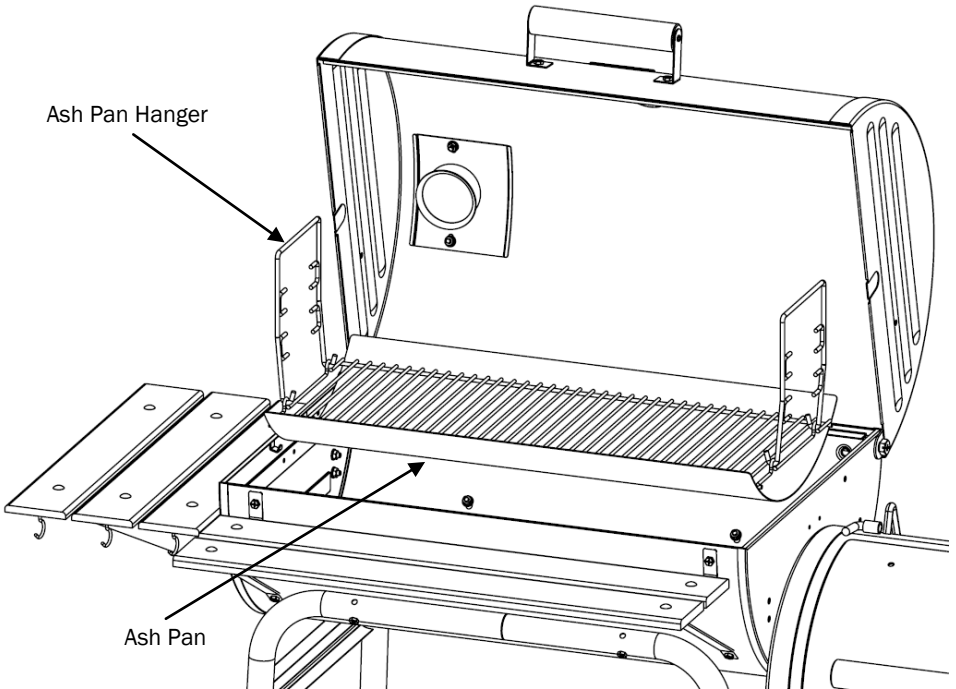

Step 15: Place Cooking Grates onto Grill Body then Install the Utensil Hooks underneath each Side Shelf Slab at the front of the Grill.

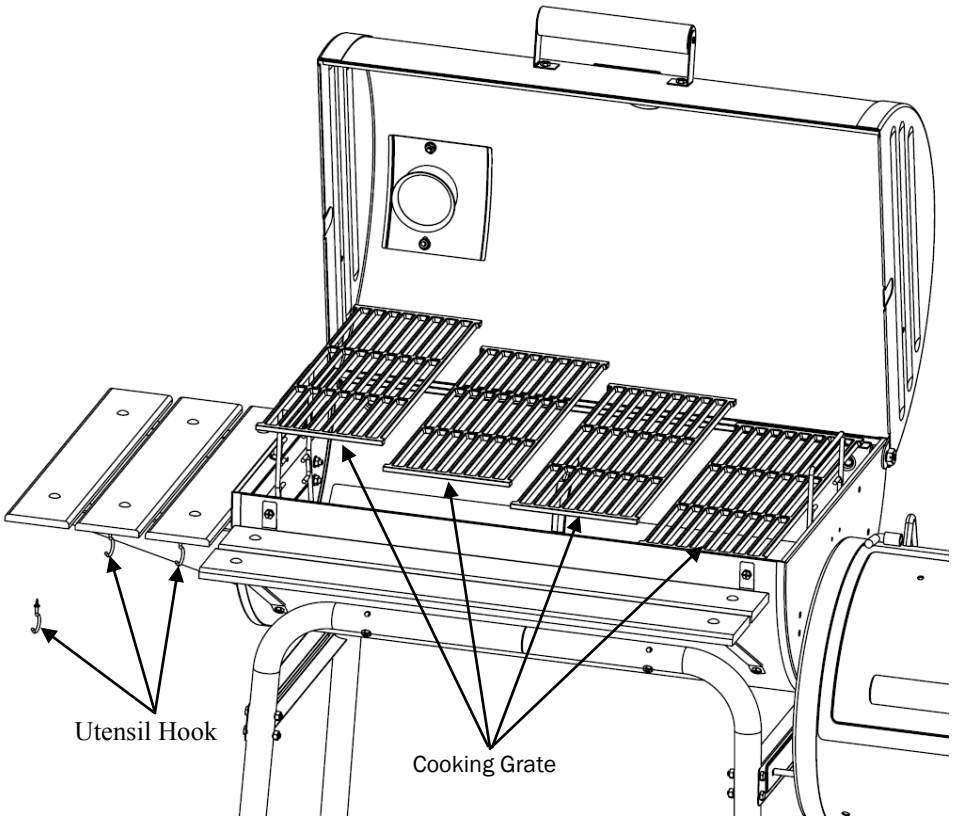

Step 16: Tighten All Bolts and Nuts.

GRILL PREPARATION & OPERATING INSTRUCTIONS

PLEASE NOTE: NO RETURNS ON USED GRILLS

**Read all safety warnings and instructions carefully
Before assembling and operating your grill.**

1. Cure GRILL prior to your initial use to protect the interior and exterior finish and to prevent unnatural flavors to your first meals. (A) Lightly coat ALL INTERIOR SURFACES (including GRILLS, GRATES, AND INSIDE OF BARREL.) with vegetable oil (spray vegetable oil is easiest but do not use near hot coals or fire). (B) Build a medium sized fire on the fire grate. (C) After coals ash over, spread out coals, replace cooking grates, close lid and heat at approximately 250 F for two hours. Re-coat GRATES and return to grill at approximately 200 F for two hours. You can lightly coat the exterior of the grill body (while warm) with vegetable oil. This will extend the life of the finish, much like waxing a car. Your GRILL will then be ready for use. NOTE: Grill will drip a lot of oil during this process and for several uses but will slow over time. **NEVER EXCEED 400 BECAUSE THIS WILL DAMAGE THE FINISH AND CONTRIBUTE TO RUST. PAINT IS NOT WARRANTED AND WILL REQUIRE TOUCH-UP. THIS UNIT IS NOT WARRANTED AGAINST RUST.**
2. To START FIRE – stack 50-60 briquets in pyramid and saturate with lighter fluid (DON'T USE GASOLINE). Light coals in several places, close lid after briquets ash over or _ gray, spread them out and start cooking. If one end burns faster, use tongs to move coals from one end to the other for even heat. **ALWAYS FOLLOW CHARCOAL AND LIGHTER FLUID MANUFACTURERS' INSTRUCTIONS AND WARNINGS. USE OUTDOORS ONLY ON NONCOMBUSTIBLE SURFACE – 15' AWAY FROM WOOD AND COMBUSTIBLE MATERIAL.**
3. Control heat with amount and type of FUEL, DUAL DAMPERS and ADJUSTABLE FIRE GRATE. Adjust GRATE one end at a time. Wood burns hotter than coals. More airflow is more heat.
4. For no flare-ups, cook with lid in the down position. Add water soaked hardwood chips for a smoked flavor.
5. Suggestion: Screw 3/4" cup hooks (not furnished) on front of the wood shelf to hang cooking utensils.
6. Burn out may be rust out. Ashes left in bottom too long hold moisture and rust through any thickness of steel. This grill is made of steel and cast iron, which WILL RUST, ESPECIALLY IF NOT PROPERLY CARED FOR.
7. Do not use self-starting charcoal as it will give unnatural flavor. Burn lighter fluid completely before closing lid.
8. After using, coat vegetable oil on interior grates and bare metal while warm to reduce rust. On the EXTERIOR, remove dust with wire brush and touch up with a high heat paint, available at most hardware/auto stores.
9. You may place a coffee can on bottom shelf under the hole in the grill to catch drippings.
10. HEAT GAUGE may obtain moisture, which will steam out during cooking. Gauge may be calibrated in oven.
11. You may fill unwanted holes with Nuts & Bolts (Not Provided). NOTE: Smoke will escape from areas other than the smokestack. This should not affect your cooking.

GRILLING RECIPES

DIRECT METHOD

STEAK (& ALL MEATS): Cook food directly above coals/heat. Generally speaking, to grill meats, raise fire grate to high position (hot) and sear for one minute on each side with the lid open to seal in flavor and juices. Then lower fire grate to medium position with lid closed and cook to desire doneness.

Control heat with dual dampers and adjustable fire grate.

BETTER BARBECUE: Place grilled meat back in the marinade for several minutes before serving – it will become tastier and juicier. CAUTION: Boil extra marinade first to kill bacteria remaining from the raw meat.

Tip: Cooking with a MEAT THERMOMETER ensures food is fully cooked. Insert into thickest part not touching bone & allow five minutes to register. Internal temperatures for BIRDS should be 170F to 180F and meat should be 140F for rare, 160F medium and 170F for well done.

MARINATED FLANK STEAK: Mix marinade ingredients in nonmetal dish. Let steak stand in marinade for no less than 4 hours in refrigerator. Brown each side for 5 minutes, but center should remain rare. Cut steak diagonally across the grain into thin slices before serving. Grill with fire grate in high (hot) position with lid open or closed.

MARINADE: 1/2 cup vegetable or olive oil, 1/3 cup soy sauce, 1/4 cup red wine vinegar, 2 tbs. Lemon juice, 1 tsp. Dry mustard, 1 minced clove garlic, 1 small minced onion, 1/4 tsp pepper.

QUAIL OR DOVES: Cover birds in Italian dressing (Good Seasons or Kraft Zesty), marinate overnight, pour off dressing and cover with Texas Pete Hot Sauce for 6 hours. Wrap birds in thick bacon secured by a toothpick. *Place on grill – keep turning until bacon is black. Grill for 20 minutes. Sear with lid open and fire grate in high (hot) position for 1 min each side before lowering grate and closing lid. *OR SMOKE by placing birds in center of GRID with fire in both ends of FIRE BOX.

KABOBS: Alternating on skewers any combination of meat, onions, tomatoes, green peppers, mushrooms, zucchini, circular slice of corn-on-the-cob, or pineapple. Meat could consist of chunks of shrimp, scallops, lobster, chicken, sausage, pork, beef, etc. Marinate the meat in refrigerator for several hours. Grill each side approximately 7 minutes turning occasionally while basting with marinade. Leave a small amount of room between pieces in order to cook faster. Grill with lid up and the fire grate in the lowest position. See marinade recipe on last page.

KABOB MARINADE: Mix 1 cup soy sauce, 1/2 cup brown sugar, 1/2 cup vinegar, 1/2 cup pineapple juice, 2 teaspoons salt, 1/2 teaspoon garlic powder and bring to a boil. Marinate beef in mixture a minimum of 4 hours.

HOT DOGS: Grill with lid up and fire grate in high (hot) position for approximately 6 minutes, turn every few minutes.

HAMBURGERS: Mix in chopped onions, green peppers, salt, sear 3/4 inch patties on each side with fire grate in high position for a few minutes. Lower fire grate to medium position and grill with lid down to avoid flare-ups. Cook each side 3 to 7 minutes according to desired doneness. Cook ground meat to 150 internally or until juice runs clear (free of blood) for prevention of E-coli. Burgers can be basted with marinade when turning and/or other ingredients can be mixed in with the ground beef such as chili sauce or powder; or you may marinate by allowing to stand in marinade for 1 or 2 hours at room temperature before cooking; or let stand in covered dish in refrigerator up to 24 hours. Bring to room temperature before cooking. See meat marinade on page 9.

SHRIMP (Peeled) & Crayfish: Place on skewers, coat with melted butter and garlic salt. Grill 4 minutes on each side or until pink. Cocktail sauce optional.

BAKED POTATOES: Rub with butter and wrap in foil and cook on grill with lid down for 50 minutes. Turn after 25 minutes (no need to turn if smoked). Squeeze to check for doneness.

SWEET CORN IN HUSKS: Trim excess silk from end and soak in cold salted water 1 hour before grilling. Grill 25 minutes – turning several times.

SMOKIN' RECIPES: using the Charcoal Grill side of the Duo with a **WATER PAN** (also called **INDIRECT METHOD**).

Pan not included. Disposable bread pan is recommended. **SMOKE BY COOKING SLOWLY** (See chart on page 27 for smoking times). 1) Place water/drip pan on left side of fire grate. 2) Place hot coals on right side (damper end) of fire grate. The charcoal basket accessory helps confine coals to one side. 3) Place meat above water pan. 4) Place fire grate in low position. 5) Close lid & control heat with dampers & adjustable grate.

You may want to sear certain foods before smoking by placing meat directly above coals with **LID** open and **FIRE GRATE** in high (hot) position for several minutes. Add flavor soaked wood chips to the fire and add 1 part marinade, beer or wine to 3 parts water to the drip pan. **OPENING THE SMOKING CHAMBER WILL EXTEND COOKING TIME.** Cooking with meat thermometer ensures food is fully cooked. Insert thermometer into thickest part not touching bone, and allow five minutes to register. Internal temperature for birds should be 170F to 180F or when leg moves easily in joint. Meat should be cooked to internal temperature of 140F for rare, 160F for medium and 170F for well done. Check the water level when cooking more than 4 hours or when you can't hear the water simmering. Add water by moving meat over and pouring water through GRILL into WATER PAN. **IF THE SMOKE IS WHITE, THE FIRE'S RIGHT. IF THE SMOKE IS BLACK, ADD SOME DRAFT.**

SMOKED TURKEY: Empty cavity rinse and pat dry with paper towel, tuck wing tips under the back and tie legs together. Place in center of cooking grid directly above foil drip pan of water. Smoke for 12 minutes per pound. Allow several extra minutes per pound if stuffed to allow for expansion. Use a meat thermometer for best results (190F internal).

SMOKED BAKED HAM: Fully cooked canned ham or smoked and cured whole ham or shank or butt portion. Place fire grate in the lowest position and a drip pan under the meat. Remove rind and score fat diagonally to give a diamond effect. Insert a whole clove in to the center of every diamond. Place ham with fat side up in center of cooking grid directly above drip pan. Close lid. About 9 minutes per pound is suggested for fully cooked hams. Smoked or cured ham which is not fully cooked should be cooked to an internal temperature of 160°. Baste with ham glaze 3 or 4 times during last 30 minutes of cooking time. Garnish with pineapple rings about 15 minutes before end of cooking time.

HAM GLAZE: 1 cup of light brown sugar, firmly packed, 1/2 cup orange juice, 1/2 cup honey, combine sugar, juice and honey. Let marinade sit for at least 4 hours.

SMOKED HOT DOGS STUFFED: Slit hot dogs lengthwise, within 1/4 inch of each end. Stuff hot dogs with cheese and relish and wrap in bacon. Place on cooking grid over drip pan and smoke 15-20 minutes or until bacon is crisp.

SMOKED CHICKEN PARTS AND HALVES: Rinse pieces in cold water and pat dry with paper towels. Brush each piece with vegetable oil and season to taste with salt and pepper. Brown pieces directly above coals with lid open and grate in high or medium position for several minutes. Then place pieces on cooking grate directly above drip pan. With the grate in the low position, cook with lid down for 55 to 60 minutes or until done. Do not use vegetable oil or salt and pepper if using marinade.

SMOKED VENISON: Place leg of venison in a container or "hefty bag" and marinate for 2-4 days, turning daily. Marinate bacon overnight in its marinade. Remove roast from refrigerator at least an hour before cooking. Season generously with seasoned salt and coarse ground black pepper. Wrap 1 lb. Bacon over the top of the roast, and smoke 20/25 minutes per pound, or until tender. Do not overcook.

Venison Marinade: 1 cup Balsamic or wine vinegar, 1 cup olive oil, 2 oz. Worcestershire, 1/2 oz. Tabasco, 2 tbs. Season All, 1 to 2 chopped jalapenos, 3 oz. Soy sauce.
Bacon Marinade: 2 ox. Wine vinegar, 2 oz. Worcestershire, 4 dashes Tabasco.

SMOKED SHRIMP & CRAYFISH: Mix in a foil pan 1/2 cup butter, two cloves of crushed garlic, Tabasco, sliced green pepper, 1 tbs each of minced onions, salt and juices from one lemon. Add shrimp and/ or crayfish and smoke 45 minutes.

SMOKED VEGETABLES: Turnips, potatoes, carrots, okra, mushrooms, peeled onions, zucchini, squash, etc. Put in pan and cover with water and cook for several hours while cooking the meat. Or place vegetables on grill and smoke for 50 minutes, either wrapped in foil or not.

SMOKED FISH: Marinate in brine (1/4 cup dissolved in 1 qt of water) or marinate fish in 1 cup white wine, 1 cup soy sauce mixed with 1 cup lemon juice. Marinate overnight in covered dish in refrigerator. Let air on rack 20 minutes before placing on Pam sprayed grill. Smoke 25 minutes.

SMOKED SPARE/BACK RIBS: Peel off tough layer of skin on back side. Rub all surfaces with seasoning. Place ribs in center of grid above drip pan and smoke approximately 1 1/2 hours or until meats pulls away from bone. Baste with barbecue sauce during last 30 minutes.

CHICKEN MARINADE: Combine 1/2 cup soy sauce, 1/4 cup vegetable oil, 1/4 cup red wine vinegar, 1 teaspoon oregano, 1/2 teaspoon sweet basil, 1/2 teaspoon garlic powder with parsley, 1/4 teaspoon pepper. Pour over chicken pieces in nonmetal dish. Cover and refrigerate overnight, turning occasionally. Use marinade to baste chicken while cooking.

MEAT MARINADE: For steaks, chops, and burgers: Combine 1 cup soy sauce, 2 coarsely chopped large onions and 2 cloves garlic (halved) in an electric blender; cover, process at high speed 1 minute or until mixture is very smooth. Stir in 1/4 cup bottle gravy coloring (Kitchen Bouquet and Gravy Master) and 2 teaspoons Beau Monde seasoning (or substitute 1 teaspoon MSG and 1 teaspoon seasoned salt). Allow meat to stand in marinade at room temperature for 2 hours or refrigerate up to 24 hours in a covered dish. Bring meat to room temperature before cooking.

SHISH KABOB MARINADE: Mix 1 cup soy sauce, 1/2 cup brown sugar, 1/2 cup vinegar, 1/2 cup pineapple juice, 2 teaspoons salt, 1/2 teaspoon garlic powder and bring to a boil. Marinate beef in mixture a minimum of 4 hours.

SMOKING TIMES



Food	Weight	Water Pan Smokin'	Side Fire Box	Temperature on Meat Thermometer
Beef Roasts, Beef Brisket	3 – 4 lbs.	1 – 1½ hours	4 – 5 hours	140° rare
Lamb Roasts, Venison	5 – 7 lbs.	1¾ – 2½ hours	5 – 6 hours	160° medium
Large cuts of Game	7 – 9 lbs.	2½ – 3½ hours	7 – 10 hours	170° well done
Pork Roasts	3 – 4 lbs. 5 – 8 lbs.	1¾ – 2½ hours 2½ – 3 hours	5 – 6 hours 7 – 8 hours	170° 170°
Pork/ Beef Ribs	Full grill	1½ – 2 hours	4 – 6 hours	Meat pulls from bone
Pork Chops	Full grill	¾ – 1¼ hour	4 – 6 hours	Meat pulls from bone
Sausage Links	Full grill	2 – 2¾ hours	4 – 5 hours	170° for fresh sausage
Ham, Fresh	10 lbs.	3 – 4 hours	7 – 8 hours	170°
Ham, Cooked	All sizes	1½ – 2 hours	3 – 4 hours	130°
Chicken (Cut up or split)	1-4 fryers, cut up or split	1 – 1¼ hours	4 – 5 hours	180° / leg moves easily in joint
Chicken (Whole)	1-4 fryers	1¼ – 1½ hour	5 – 6 hours	180° / leg moves easily in joint
Turkey (Unstuffed)	8 – 12 lbs.	1¾ – 2½ hours	7 – 8 hours	180° / leg moves easily in joint
Fish, small whole	Full grill	½ – ¾ hours	2 – 3 hours	Flakes with fork
Fish, filets, steak	Full grill	¼ – ½ hours	1 – 3 hours	Flakes with fork
Duck	3 – 5 lbs.	1 – 1¾ hours	5 – 6 hours	180° / leg moves easily in joint
Small game birds	Full grill	¾ – 1 hour	4 – 5 hours	180° / leg moves easily in joint



IMPORTANT SAFETY WARNINGS

READ ALL SAFETY WARNINGS AND INSTRUCTIONS CAREFULLY BEFORE ASSEMBLING AND OPERATING YOUR GRILL

- Use caution when assembling and operating your grill to avoid scrapes or cuts from sharp edges.
- Do not use gasoline, kerosene or alcohol for lighting charcoal. Use of any of these or similar products could cause an explosion possibly leading to severe bodily injury.
- Keep children & pets away from grill. Supervision is necessary and do not leave grill unattended when in use. Use caution when moving grill to prevent strains. Keep grill at least 15 feet from any combustible material (decks, buildings, fences, trees, bushes, etc).
- When adding charcoal and/or wood, use extreme caution.
- Never move grill when it is in use or when it contains hot coals or ashes.
- Do not place grill near flammable liquids, gases or where flammable vapors may be present.
- Use caution since flames can flare-up when fresh air suddenly comes in contact with fire. When opening the lid, keep hands, face and body safe from hot steam and flame flare-ups.



IMPORTANT SAFETY WARNINGS

READ ALL SAFETY WARNINGS AND INSTRUCTIONS CAREFULLY BEFORE ASSEMBLING AND OPERATING YOUR GRILL

- Do not exceed a temperature of 400 F. Do not allow charcoal and/or wood to rest on the walls of grill. Doing so will greatly reduce the life of
- Always wear oven mitts to protect hands from burns. Avoid touching hot surfaces.
- When opening lid, make sure it is pushed all the way back so it rests against the lid support brackets. Use extreme caution as hood could fall back to a closed position and cause bodily injury.
- Close lid and all dampers to help suffocate flame.
- Always hold an open lid from the wooden handle to prevent it from closing unexpectedly.
- Never leave coals and ashes unattended. Before grill can be left unattended, coals and ashes must be removed. Use caution to protect yourself and property. Carefully place remaining coals and ashes in a noncombustible metal container and saturate completely with water. Allow coals and water to remain in metal container 24 hours prior to disposing.
- To protect against bacteria that could cause illness, keep all meats and refrigerated and thaw in refrigerator or microwave; keep raw meats separate from other foods; wash everything that contacts raw meats; cook thoroughly; and refrigerate leftovers immediately. Cook meats medium to well one.

THESE WARNINGS APPLY ALSO TO THE "SIDE FIRE BOX"

Smokin' Pro 1224

ACCESSORIES ORDER FORM



TO ORDER

Visit:

www.chargriller.com

or

CALL: 912-638-4724

or

FAX: 912-638-2580

or MAIL:

P.O. Box 30864

Sea Island, GA

31561



FedEx



Visit our online store at:

www.chargriller.com

for more Char-Griller®

Professional Accessories™

Professional Accessories™ Branded with Char-Griller® Logo

ALL TOOLS: STAINLESS STEEL & HARDWOOD HANDLES

• Cover #5555

- Custom Fit, Weather Resistant
- Protects grill finish
- Cover Accommodates Side Shelf or Side Fire Box
- Grill cover #5555 fits with Side Fire Box or Side Shelves



• Rotisserie #5022

- Excellent for effortless grilling
- Universal Fit for Most Grills



• Apron #8805

- Machine Washable
- Two Front Pockets
- Adjustable Straps



(continued on next page)



P.O. Box 30864
Sea Island, GA
31561
912-638-4724
www.CharGriller.com

OWNER'S MANUAL

GAS PRODUCTS

WARNING: This product is equipped to operate on propane gas which contains benzene, a chemical known to the State of California to cause cancer, birth defects, or other reproductive harm. This product and combustion by-products produced when using this product contain chemicals known to the State of California to cause cancer, birth defects, or other reproductive harm.

CHARCOAL / PELLETS PRODUCTS

WARNING: This product and combustion by-products produced when using this product contain chemicals known to the State of California to cause cancer, birth defects, or other reproductive harm.

PACKAGING (All Products)

WARNING: Chemicals known to the state of California to cause cancer, birth defects or other reproductive harm are created by the combustion of propane, charcoal, or other wood products.

Warranty Information — Charcoal Grill

Char-Griller® will repair or replace any defective part of its grillers/smokers for a period of up to one year from the date of purchase. Char-Griller® will also repair or replace the body (bottom half) of its grillers/smokers if the metal is rusted through or burned through for a period up to five years. Char-Griller will repair or replace any defective part of its side fire boxes for a period up to one year from the date of purchase.

Proof of purchase, proof of purchase date, photo and prepaid return of the item in question may be required. Misuse, abuse, or commercial use nullifies all warranties. Paint/finish is not warranted. Products are not warranted against rust.

The warranty is for replacement of defective parts only. Manufacture will not be responsible for damage resulting from accident, alteration, misuse, abuse, hostile environments, improper installation, installation not in accordance with local codes of service of unit.

This limited warranty does not cover any scratches, dents, corrosion or discoloring by heat, abrasive and chemical cleaners nor any components used in the installation of the appliance.

Save your receipt for all warranty claims.





**P.O. Box 30864
Sea Island, GA
31561
912-638-4724
www.CharGriller.com**