



2190 Dagenais Blvd. West
LAVAL (QUEBEC)
CANADA
H7L 5X9

TEL: 514.337.4415
FAX: 514.337.4029

info@burcam.com



INSTALLATION INSTRUCTIONS

MODEL 400505 SEWAGE PUMPS

Your pump has been carefully packaged at the factory to prevent damage during shipping. However, occasional damage may occur due to rough handling. **Carefully inspect your pump** for damages that could cause failures. Report any damage to your carrier or your point of purchase.

Please read these instructions carefully. **Failure** to comply to instructions and **designed** operation of this system, may void the warranty.

INITIAL START UP PROCEDURES:

1. Inspect the pump and the sewage tank for any obvious condition that may necessitates cleaning, correction, adjustment or repair.
2. Assure that the pump is secure and vertical for proper operation.
3. Assure that there is adequate clearance from any combustible materials or structure. Stored materials must be kept away from the pump. Shelves or cabinet structures must not be in close proximity over the pump.
4. Assure that the motor is securely plugged into a proper 'GFCI' electrical outlet.
5. Test the 'GFCI' outlet by pressing its test switch. This should prove that the outlet is energized and will trip off to protect against a ground fault. Be sure to reset the 'GFCI' by pressing its reset switch.
(Repeat this step monthly)
6. Lift the float to assure that the pump will start when required. (Step 7 below will test submersible pumps with enclosed floats).
7. Pour pails of water in the sewage tank to turn the pump on. Assure that any check valve present will permit the sewage to flow.
8. Observe that the plumbing can pump the sewage safely out of the residence.
(Repeat this step monthly)



SAFETY INSTRUCTIONS:

Before installation and operation, follow these procedures:

- A** Check with your local electrical and plumbing codes to ensure you comply with the regulations. These codes have been designed with your safety in mind. Be sure you comply with them.
- B** A separate circuit must be lead from the home electrical distribution panel properly protected with a fuse or a circuit breaker. We also required that a ground fault circuit be used as well as a 'GFCI' receptacle. Consult a licensed electrician for all wiring.
- C** The ground terminal on the three prong plugs should never be removed. They are supplied and designed for your protection.
- D** Never make adjustments to any electrical appliance or product with the power connected. Do not only unscrew the fuse or trip the breaker, remove the power plug from the receptacle.

Electrical Connection

For pumping systems using more than one pump, each pump needs to be connected to a separate dedicated circuit protected by a fuse or breaker. This way, the power supply of one pump will not stop operating if the fuse of one of the pumps burns or if the breaker of one of the pumps trips.

Material required for sewage pump application

- Desired length of ABS/DWV 2" pipe, to link up from pump discharge to waste or drain existing pipe.
- Required quantities of 2" ABS/DWV elbow(s) and/or other fitting(s) to run the discharge line.
- 1 only 2" ABS/DWV male adaptor to 2" slip, to connect the discharge pipe to the pump.
- Desired length of ABS/DWV 3" pipe and required quantities of 3" ABS/DWV elbow(s) and/or other fitting(s) to run the vent line.
- 1 only 2" union check valve # 450457.
- 1 only 18" X 30" minimum size sewage basin like # 400420.
- Teflon tape and ABS cement.

NOTICE

This unit is not designed for applications involving salt water or brine. Use with salt water or brine will void warranty.

TOOLS

Screwdrivers, hacksaw to cut pipe, knife to assist in pipe cutting, round file to smooth pipe ends, pipe wrench, adjustable wrench, 1/4" drill bit and drill.

Ensure that you have a gas tight cover for your sewage basin and 3" ABS/DWV vent piping.

APPLICATIONS

- Designed for a permanent installation for homes and cottages application. To pumping where the total head requirements do not exceed 15 feet, including pipe friction losses.

CAPACITY:

5'	3600	USGPH	13600	LPH
10'	3060	USGPH	11600	LPH
15'	1260	USGPH	4775	LPH

FRICITION LOSS IN
PIPE NOT INCLUDED

FEATURES

- Vortex designed impeller made from noryl, will not corrode.
- Rugged cast iron pump body.
- Stainless steel mechanical rotary type motor seal.
- 2" NPT pump discharge.
- Thermal and overload protection.
- Mechanical type float switch, 15A.
- 4/10HP, 115VAC, 60Hz, 4A, (8A when start).

IMPORTANTE NOTICE

The following are minimum requirements in order to protect your residence from flooding. It is a small investment but it is your personal responsibility to protect your home, family and valuables. Failure to comply with the following requirements will also void your warranty:

- Two (2) pumps have to be installed in the sewage pit. The first pump as a primary pump and the second pump as the backup unit.
- An Alarm system model T50454 has to be installed to advise you of any malfunctions.

Pump selection, proper and adequate installation are a must to comply with local by-laws and need to be adhered to.

INSTALLATION STEPS

See typical installation diagram in page 4

STEP 1

We recommend that you install your pump and basin in a clean location where there is adequate room for servicing at a later date. Protection from freezing temperatures and good ventilation should be considered as well, to provide the pump an environment for long life.

Assuming that you have a sump pit located in your basement floor... Your sump pit should be constructed from concrete, brick, tile or more recently a sump basin made from plastic and/or fiberglass. The minimum size of your sump pit must be 18" in diameter and no less than 25" deep. When pit is ready, proceed to next step.

Friction losses in the discharge pipe must be taken into consideration when many elbows and fittings are installed in the discharge line. Each elbows and fittings must be considered as 1 feet of head.

Never run the pump dry. Damage to the seal may occur.

The run of the pipe from the check valve to the existing waste or drain line must never be slooping downward except when connecting to same.

STEP 2

For a new installation, install your sewage basin in the excavation you have provided in the basement floor of your home. Connect the necessary piping from your shower trap, toilet, etc., to the inlet of your sewage basin, with the proper pipe and fittings (see diagram).

STEP 3

Cut a length of 40" to 42" of 2" ABS/DWV pipe. Cement the 2" ABS/DWV male adaptor to 2" slip to one end of this pipe.

STEP 4

With your drill, make a 1/4" hole in the adaptor previously glued. This hole will prevent any air locking wich might occur.

STEP 5 Screw the pipe with the male adaptor into the 2" discharge opening in the pump. Lower pump with piping attached into the sewage basin. Make sure that the pump is as close as possible to the centre of the basin. Adjusting the pump in centre of basin will keep mechanical float switch from rubbing on side of basin.

STEP 6 When you are pumping raw sewage, you must have a gas tight cover on the basin and a vent pipe from basin, connecting to home's vent system (see diagram). Feed the 2" riser pipe from pump's discharge, through the 2" opening in the cover. Secure a 3" vent pipe to the cover and bring the switch and pump motor power cables through the opening in the cover provided.

STEP 7 Install a 2" check valve (model 450457) union type to the 2" discharge riser pipe coming out of the cover, to a length of 2" ABS/DWV pipe, and run the discharge line as short as possible to the home's waste sewer line. Secured the check valve with the provided clamps. Be sure that the arrow on valve are pointing away from pump.

STEP 8 Connect the 3 prong plug of the switch in a receptacle. Insert the motor 3 prong plug into female receptacle on exposed piggy-back of switch plug. The mechanical switch provided for automatic operation is preset to pump. No adjustments are necessary.

STEP 9 Fill the sewage basin with water to test the operation of the submersible sewage pump and switch operation. Pump should start pumping when the water level reaches 12" to 15" above the bottom of the basin and above the pump. Allow the pump to go several "on-off" cycles to assure satisfactory operation.

STEP 10 Secure the gas tight cover and the plug for electrical cords with the gaskets and screws provided with the cover. Make vent connection to home's vent system.

SEWAGE SYSTEM TYPICAL PIPING

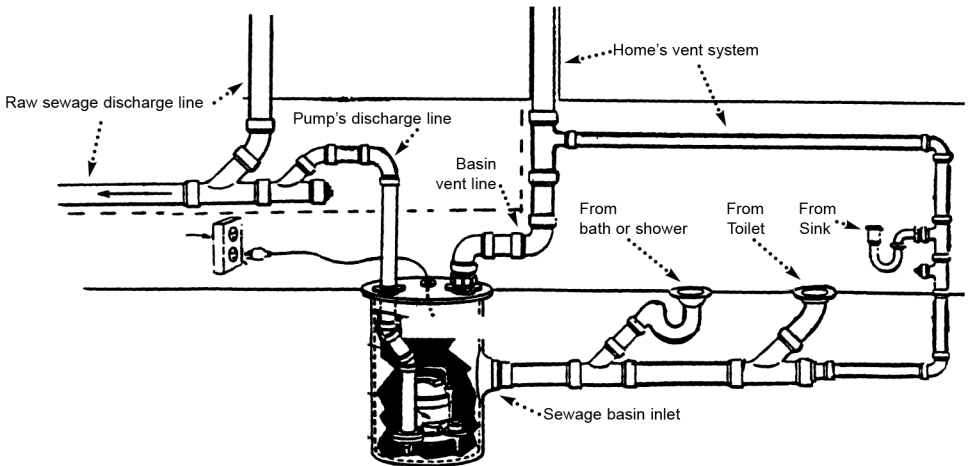

SEWAGE PUMP APPLICATION

STEP 7

Install check valve

STEP 6

Set gas tight cover, discharge and vent pipes

STEP 8

Connect to receptacle

STEP 10

Secure cover and make vent connection

STEP 5

Install discharge pipe and lower pump in centre of basin

STEP 9

Fill with water and test operation

STEP 2

Install sewage basin

STEP 4

Drill a 1/4" hole

STEP 3

Cement 2" adaptor to pipe

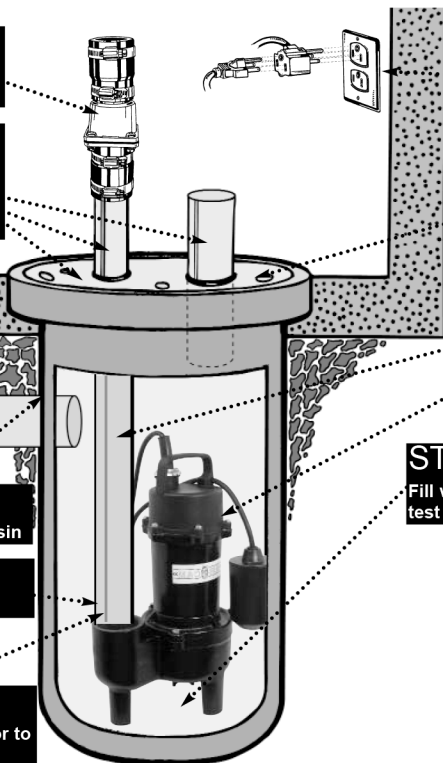

REPAIR PARTS

#	REF	DESCRIPTION	#	REF	DESCRIPTION
1	410013	Power cable	11	410010	Oil seal
2	410017	Power cable adaptor	12	350340	Lower bearing
3	410001	Upper casing	13	506062	Body cap screw
4	410014	Capacitor	14	410003	Motor housing
5	410002	Upper bearing cover	15	410005	Stator
6	410009	Upper bearing	16	410012	O-Ring
7	410006	Seal plate	17	410016	Plug screw
8	410007	Volute base	18	410015	Handle
9	410008	Impeller	19	450453	Mechanical float switch
10	410011	Mechanical seal			

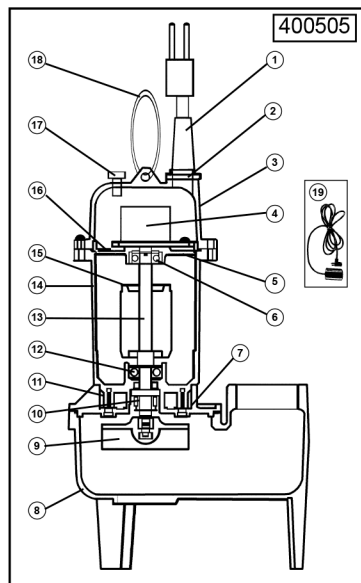

TROUBLE SHOOTING GUIDE CHECKLIST

NEVER MAKE ADJUSTMENTS TO ANY ELECTRICAL APPLIANCE OR PRODUCT WITH THE POWER CONNECTED. DON'T JUST UNSCREW THE FUSE OR TRIP THE BREAKER, REMOVE THE POWER FROM THE RECEPTACLE.

TROUBLE	PROBABLE CAUSE	ACTION
Motor does not run.	Switch is off position Blown fuse Tripped breaker Disconnected plug Corroded plug Float stuck Defective switch Defective motor	Turn switch to on position Replace Reset Re-install Clean Check movement Replace Replace
Motor runs but no water is delivered.	Improper voltage Pump may be airlocked Pump discharge head too high Clogged inlet/impeller	Check voltage Check drilled hole in discharge pipe Wrong pump selection (over 15') Clean
Pump does not deliver to full capacity.	Improper voltage Pump may be airlocked Pump discharge head too high Clogged inlet/impeller	Check voltage Check drilled hole in discharge pipe Wrong pump selection (over 15') Clean
Pump does not shut off.	Defective switch Missing check valve Clogged check valve in open position Float obstruction	Replace Install valve Clean debris Check for movement

TO THE END CONSUMER

If you have any problems with the product, before advising the store, where you've purchased the pump, please contact us at 514 337-4415 , and ask for our sales department, and they will be pleased to help you with any questions you might have, concerning your installation.