

# INSTALLATION INSTRUCTIONS

**MODEL**

**300608**

version H / Z

**SUBMERSIBLE  
SUMP PUMP**

2190 Dagenais Blvd. West  
LAVAL (QUEBEC)  
CANADA  
H7L 5X9

TEL : 514.337.4415  
FAX : 514.337.4029  
info@burcam.com

Your pump has been carefully packaged at the factory to prevent damage during shipping. However, occasional damage may occur due to rough handling. **Carefully inspect your pump** for damages that could cause failures. Report any damage to your carrier or your point of purchase.

Please read these instructions carefully. **Failure** to comply to instructions and **designed** operation of this system, may **void** the warranty.

## NOTICE

This unit have been designed to pump water only. This unit is not designed for applications involving salt water, brine or any other liquids including petroleum products. Use with salt, brine or any other liquids including petroleum products will void the warranty.

## ELECTRICAL CONNECTION

For pumping systems using more than one pump, each pump needs to be connected to a separate dedicated circuit protected by a fuse or breaker. This way, the power supply of one pump will not stop operating if the fuse of one of the pumps burns or if the breaker of one of the pumps trips.



## SAFETY INSTRUCTIONS:

This fine pump that you have just purchased is designed from the latest in material and workmanship. Before installation and operation, we recommend the following procedures:

- A** CHECK WITH YOUR LOCAL ELECTRICAL AND PLUMBING CODES TO ENSURE YOU COMPLY WITH THE REGULATIONS. THESE CODES HAVE BEEN DESIGNED WITH YOUR SAFETY IN MIND. BE SURE YOU COMPLY WITH THEM.
  
- B** WE RECOMMEND THAT A SEPARATE CIRCUIT BE LEAD FROM THE HOME ELECTRICAL DISTRIBUTION PANEL PROPERLY PROTECTED WITH A FUSE OR A CIRCUIT BREAKER. THE MOTOR HAVE TO BE SECURELY PLUGGED INTO A PROPER 'GFCI' ELECTRICAL OUTLET. CONSULT A LICENSED ELECTRICIAN FOR ALL WIRING.
  
- C** THE GROUND TERMINAL ON THE THREE PRONG PLUGS SHOULD NEVER BE REMOVED. THEY ARE SUPPLIED AND DESIGNED FOR YOUR PROTECTION.
  
- D** NEVER MAKE ADJUSTMENTS TO ANY ELECTRICAL APPLIANCE OR PRODUCT WITH THE POWER CONNECTED. DO NOT ONLY UNSCREW THE FUSE OR TRIP THE BREAKER, REMOVE THE POWER PLUG FROM THE RECEPTACLE.

### MONTHLY MANDATORY CHECK-UP :

1. Inspect the pump and the sump for any obvious condition that necessitates cleaning, correction, adjustment or repair.
2. Clear the sump and the surroundings of any paper, leaves or other debris that might clog the input openings. Remove anything that might float into the suction area.
3. Assure that the pump is secure and vertical for proper operation.
4. Assure that there is adequate clearance from any combustible materials or structure. Stored materials must be kept away from the pump. Shelves or cabinet structures must not be in close proximity over the pump.
5. Test the 'GFCI' outlet by pressing its test switch. This should prove that the outlet is energized and will trip off to protect against a ground fault. Be sure to reset the 'GFCI' by pressing its reset switch.
6. Lift the float to prove that the pump will start when required. (Step 8 below will test submersible pumps with enclosed floats).
7. Put the necessary pail of water in the sump to prove that any check valve present will permit effluent to flow.
8. Observe that the plumbing can carry the effluent safely out of the residence.

### MATERIAL REQUIRED FOR A SUBMERSIBLE SUMP PUMP APPLICATION

- Desired length of 1½" or 1¼" of ABS/DWV pipe to link up the pump to the drain line.
- 1 1¼" check valve (350353) or 1½" check valve (350363).
- Required adaptor to connect the check valve to the discharge pipe.
- Sump pit or 1 only sump basin.
- 1¼"- 1½" stainless steel clamps (750886), if required.
- ABS cement.

### Tools

**Screwdrivers, hacksaw to cut pipe, knife to assist in pipe cutting, round file to smooth pipe ends, pipe wrench, adjustable wrench to tighten fittings.**

## APPLICATION

- This submersible sump pump is designed for a permanent sump installation.
- To be used in a residential cottage and farm application.

## FEATURES

- Stainless steel mechanical rotary seal.
- Thermal and overload protection.
- Piggy back grounded cables
- 115VAC, 60Hz.
- 1/3 HP 7.0 A, (14.0 A at start)

## CAPACITIES

	<u>LPH</u>		<u>US GPH</u>
1,5m	11525	5'	3050
3,0m	7675	10'	2025
4,5m	3475	15'	925
5,5m	900	18'	235

FRICITION LOSS IN  
PIPE NOT INCLUDED

## INSTRUCTION STEPS

### IMPORTANT NOTICE

Please note before you proceed with the installation of this product that the manufacturer's guideline **has to** be respected. Failure to comply may void your warranty.

The following are minimum requirements in order to protect your residence from flooding. It is a small investment but it is your personal responsibility to protect your home, family and valuables. Failure to comply with the following requirements may also void your warranty:

- Two (2) pumps **have to** be installed in the sump pit. The first pump as a primary pump and the second pump as the backup unit.
- Burcam alarm system model 450454 **has to** be installed to advise you of any malfunctions.
- As sump pumps are electrically powered and activated so to prevent flooding, a Burcam battery powered back up pump model 300403 **has to** be installed to evacuate the water.

Pump selection, proper and adequate installation are a must to comply with local by-laws and need to be adhered to.

### STEP 1

We recommend that you install your pump in a clean location where there is adequate room for servicing at a later date. Protection from freezing temperatures and good ventilation should be considered as well, to provide the pump an environment for long life. **Do not use to pump gas or toxic fuels. This submersible sump pump is designed to pump water only.**

Friction losses in the discharge pipe must be taken into consideration when the horizontal offset is greater than 50 feet. The discharge pipe should be increased from 1 1/2" to 2". This will reduce friction losses and allow the pump to give maximum performance. More friction losses must also be taken into consideration when many elbows and fittings are installed in the discharge line. Each elbows and fittings must be considered as 1 feet of head. The float switch of your pump has been pre-set at the factory and does not need any adjustment.

**Never run the pump dry.** Damage to the seal may occur. Fill pump pit or sump basin with water before turning on the power.

### STEP 2

Assuming that you have a sump pit located in your basement floor... Your sump pit must be constructed from concrete, brick, tile or more recently a sump basin made from plastic and/ or fiberglass. The minimum size of your sump pit must be 18" in diameter and no less than 25" deep. When pit is ready, proceed to next step.

# SUMP PUMP APPLICATION

(SEE DIAGRAM ON PAGE 5)

## STEP 3

At this step, you have the opportunity to install a 1 1/2" or a 1 1/4" discharge. We recommend a 1 1/2" ABS/DWV discharge. Install a check valve (350362 in-line 1 1/2" or 350353 1 1/4" MNPT inlet and 1 1/4" or 1 1/2" outlet or 350363 1 1/2" MNPT inlet and 1 1/2" or 2" outlet) over discharge pipe of your pump and secure it with stainless steel clamps or glued nipple for ABS/DWV pipe. This check valve will allow easy access to pump, should service be required.

## STEP 4

Install and position your submersible sump pump in the centre of your sump pit or basin and ensure that there is clearance to allow the mechanical float switch a free working area without obstructions (pipe, pit's wall, power cord). The float cord length is factory set and should not need adjustment. If adjustment is required, the switch cord can be shorted or lengthed.

## STEP 5

Install your discharge pipe from check valve to the point of discharge or drain. For installation over 50 feet of horizontal position discharge pipe, use a 2" pipe to reduce friction loss.

## STEP 6

The mechanical switch provided with your pump is supplied with a serial electrical male plug. Fix the power cord of the pump into the piggy-back receptacle of the switch and plug this one into electrical grounded outlet. We recommend that a licensed electrician be employed to do wiring. Permanently ground the motor in accordance to the electrical codes for your area. Do not use an extension cord to connect your pump to the power source. From your distribution panel to the receptacle, we recommend a wire gauge not smaller than 14 gauge. Use tape or tie wrap to fix power cords to discharge pipe.

## STEP 7

Fill the sump pit or basin with water to test the operation of your submersible sump pump. The motor should start when the water level reaches approximately 3" over your pump. Allow the pump to go through several "on-off" cycle to assure satisfactory operation. If needed, see trouble shooting guide in this manual.

## STEP 8

Review your installation with typical diagram. Check all connections for leaks.

# MAINTENANCE

Unplug the switch and pump motor power cord. Remove the pump from pit or basin. Remove trash accumulation and dirt from the pump and float switch. Be sure the float switch operates freely after cleaning. If tar or paint has been received in the pit or basin, use kerosene to remove residue from float switch or pump. **Do not use strong paint solvents.** Be sure impeller turns freely after cleaning.

Check and clean away any debris which may be clogging the suction inlet, pump discharge, check valve and discharge line. Return sump pump to sump pit or basin and reconnect to piping.

## SUMP PUMP APPLICATION

### STEP 3

Prepare your choice of discharge pipe size and check valve

### STEP 2

Sump pit 18" diameter X 25" depth

### STEP 7

Fill the basin and test the operation

### STEP 8

Review and check connections for leaks

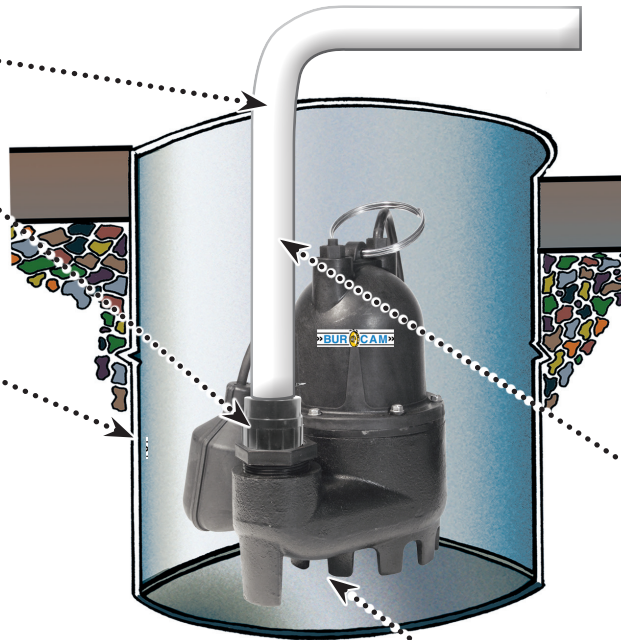

### STEP 6

Connect float and motor power cables

### STEP 5

Install discharge pipe

### STEP 4

Install your pump in centre of pit

## REPAIR PARTS

REF.	PART	DESCRIPTION
1	310264	Pump Casing
2	310265	Impeller
3	350277	Reducing adaptor
4	310266	Oil Seal
5	310267	O Ring
6	310268	Screw
7	310269	Cable Cord And Nut
8	310270	Handle
9	450453A	Mechanical Switch
10	310271	Motor Assembly

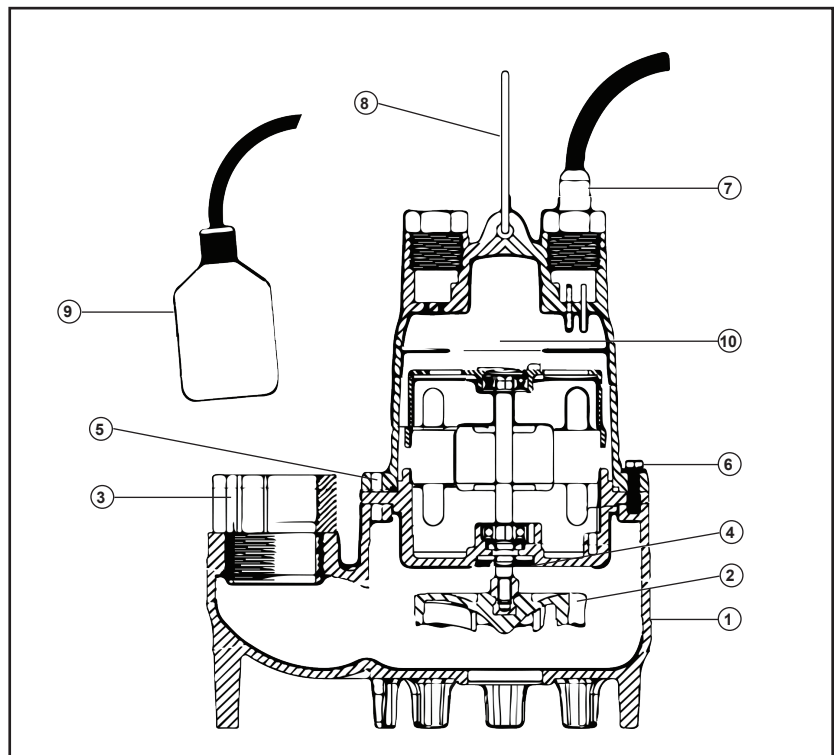

Repair parts may be ordered from your authorized point of sale or from BUR-CAM PUMPS

# TROUBLE SHOOTING GUIDE CHECKLIST

NEVER MAKE ADJUSTMENTS TO ANY ELECTRICAL APPLIANCE OR PRODUCT WITH THE POWER CONNECTED. DON'T JUST UNSCREW THE FUSE OR TRIP THE BREAKER, REMOVE THE POWER FROM THE RECEPTACLE.

TROUBLE	PROBABLE CAUSE	ACTION
<b>Motor does not run.</b>	<ul style="list-style-type: none"> <li>Switch is off position</li> <li>Blown fuse</li> <li>Tripped breaker</li> <li>Plug disconnected</li> <li>Corroded plug</li> <li>Low water level</li> <li>Thermal overcharge</li> <li>Defective switch/float</li> <li>Defective motor</li> <li>Improper float position</li> </ul>	<ul style="list-style-type: none"> <li>Turn switch to on position</li> <li>Replace</li> <li>Reset</li> <li>Re-install</li> <li>Clean prongs</li> <li>Add water and verify</li> <li>Cool the motor</li> <li>Replace</li> <li>Replace/repair</li> <li>Check movement</li> </ul>
<b>Pump does not deliver to full capacity.</b>	<ul style="list-style-type: none"> <li>Jammed impeller</li> <li>Plugged check valve</li> <li>Blocked suction/inlet</li> <li>Discharge leak</li> <li>Blocked line/pipe</li> <li>Worn impeller</li> <li>Defective motor</li> </ul>	<ul style="list-style-type: none"> <li>Clean</li> <li>Clean/replace</li> <li>Check for debris in pit and clean</li> <li>Repair</li> <li>Check for debris or ice</li> <li>Repair/replace</li> <li>Replace</li> </ul>
<b>Pump does not shut off</b>	<ul style="list-style-type: none"> <li>Defective switch</li> <li>Float obstruction</li> <li>Blocked suction/inlet</li> </ul>	<ul style="list-style-type: none"> <li>Replace</li> <li>Adjust/check</li> <li>Check for debris in pit and clean</li> </ul>

**TO THE END CONSUMER**

*If you have any problems with the product, before advising the store, where you've purchased the pump, please contact us at 514 337-4415 , and ask for our sales department, and they will be pleased to help you with any questions you might have, concerning your installation.*