

# FIRE EXTINGUISHER BRACKET

CAT. **FEBRA2-6**  
**FEBRA5-6**

## DURABLE METAL CONSTRUCTION

Steel bracket with stainless steel straps

## CORROSION RESISTANT FINISH

Black coated finish resists corrosion,  
rust and chips.

## APPROVED FOR MARINE USE

Approved for marine use when used  
with the following First Alert fire  
extinguisher models:

**FEBRA2-6:**  
*FE5GR, FE10GR and FE1A10GR*

**FEBRA5-6:**  
*FE2A10GR, FE3A10GR, FE3A40GR*

# First Alert®

## Fire Extinguisher Bracket for 2.5 lb. and 5.0 lb. Fire Extinguishers

### Description:

First Alert Cat. No. FEBRA2-6 and FEBRA5-6 are heavy duty steel mounting brackets designed to fasten First Alert brand fire extinguishers in marine, automotive and in-cab truck applications or anywhere a more secure installation is needed. Their durable metal construction have a corrosion resistant coated finish with stainless steel straps.

The FEBRA2-6 is designed for 2.5 lb. First Alert fire extinguishers. The FEBRA5-6 is designed for 5.0 lb. First Alert fire extinguishers. When used with the following First Alert fire extinguisher models, they are approved to United States Coast Guard (U.S.C.G.) standards for marine applications, approval number 162.028/EX3622:

**FEBRA2-6:**  
FE5GR, FE10GR and FE1A10GR

**FEBRA5-6:**  
FE2A10GR, FE3A10GR, FE3A40GR



**FEBRA2-6**

**FEBRA5-6**



U.S.C.G. Marine  
Approved

Listed to  
UL 299 &  
UL 711  
Standards

# CAT. FEBRA2-6 / FEBRA5-6

## OVERALL DIMENSIONS

FEBRA2-6

FEBRA5-6

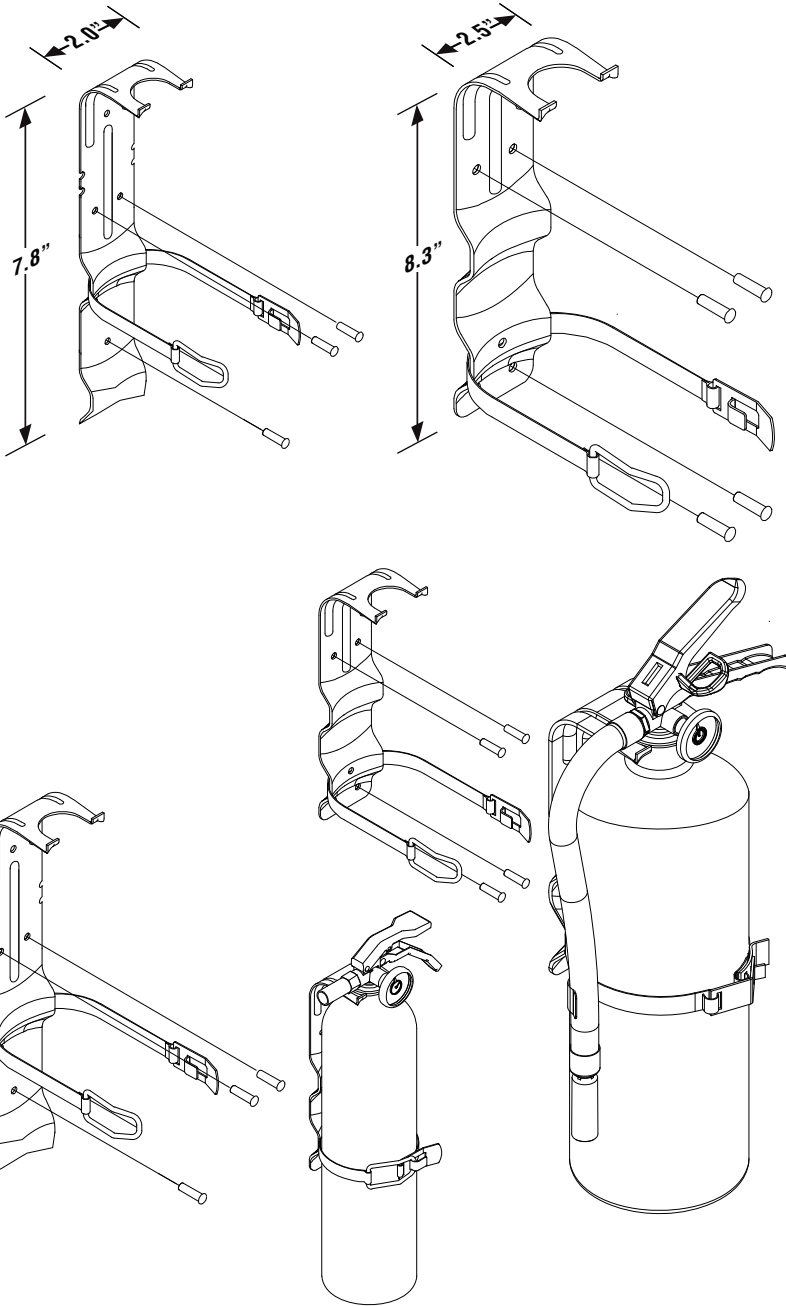

## TECHNICAL SPECS

Dimensions:	7.8"H x 2.0"W (FEBRA2-6) 8.3"H x 2.5"W (FEBRA5-6)
Weight:	0.49 lbs. (FEBRA2-6) 0.94 lbs. (FEBRA5-6)
Construction:	Black powder coated steel body with stainless steel straps
Application:	FE5GR, FE10GR, FE1A10GR (FEBRA2-6) FE2A10GR, FE3A10GR, FE3A40GR (FEBRA5-6)

## SHIPPING SPECS:

Individual Carton Dimensions	3.63 "L x 2.19"W x 11.75"H (FEBRA2-6) 3.50 "L x 2.75"W x 14.25"H (FEBRA5-6)
Weight	0.68 lbs. (FEBRA2-6) 1.2 lbs. (FEBRA5-6)
Cube	0.05 ft3 (FEBRA2-6) 0.08 ft3 (FEBRA2-6)
UPC	0 29054 00100 9 (FEBRA2-6) 0 29054 00101 6 (FEBRA5-6)

Master Carton Dimensions	7.75"L x 7.75"W x 12.31"H (FE3A40GR-2) 9.50"L x 8.00"W x 14.88"H (FE3A40GR-6)
Master Pack	6
Weight	4.0 lbs. (FEBRA2-6) 7.5 lbs. (FEBRA5-6)
Cube	0.43 ft3 (FE3A40GR-2) 0.65 ft3 (FE3A40GR-6)
12 of 5	600 29054 00100 1 (FEBRA2-6) 600 29054 00101 8 (FEBRA5-6)

Pallet Information	
Cases per Layer	30 (FEBRA2-6) 25 (FEBRA5-6)
Number of Layers	3
Cases per Pallet	90 (FEBRA2-6) 75 (FEBRA5-6)
Units per Pallet	540 (FEBRA5-6) 450 (FEBRA5-6)
Cube	43.7 ft3 (FEBRA2-6) 54.6 ft3 (FEBRA5-6)
Weight	425 lbs. (FEBRA2-6) 628 lbs. (FEBRA5-6)

## ARCHITECTURAL AND ENGINEERING SPEC

The fire extinguisher bracket shall be a First Alert Model FEBRA2-6 for 2.5 lb. applications and FEBRA5-6 for 5 lb. applications and shall provide at a minimum the following features and functions:

1. Steel construction with a corrosion resistant coating and stainless steel straps.
2. U.S. Coast Guard approved for marine use with approved bracket. Marine Type, U.S. Coast Guard Type-A-Size II, Type-B:C-Size I. Approval 162.028/EX3622. Valid only with bracket assembly FEBRA2-6 or FEBRA5-6 bracket numbers.
3. The unit shall at a minimum be listed to and meet the requirements of UL711, ULC-S508, UL299 and ULC-S504.

**BRK**<sup>®</sup>  
THE PROFESSIONAL STANDARD  
brkelectronics.com

©2009 BRK Brands, Inc. a Jarden Corporation  
Company (NYSE: JAH)  
3901 Liberty Street Road  
Aurora, IL 60504-8122  
All rights reserved.

First Alert is a registered trademark of the First Alert Trust  
BRK is a registered trademark of BRK Brands, Inc.  
Plus-Fifty C is a registered trademark of Ansul, Inc.  
CM2941