

BEFORE STARTING THE INSTALLATION

Compare the requirements of the installation with the specifications below, to make sure the correct model of CLOSER will be installed.

Type	UL 3 Hr Fire Rated
Closer Size	3
Maximum Door Width	38"
Maximum Door Weight	125 lbs
Maximum opening angle for closer (mounted on door or top jamb)	120° or 155°

1. PARTS AND ASSEMBLY DIAGRAM

Tools needed for installation: hammer, Phillips head screwdriver, punch, electric drill, tape, #12-24 tap for metal doors and jambs. Check that all parts shown in the parts list and in the illustration are present. Match screw size and type to hardware drawing.

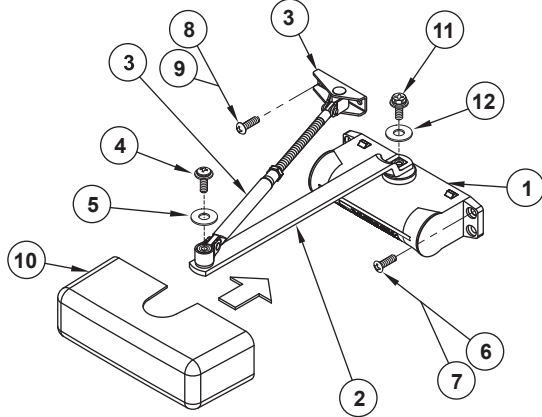

Ref No.	Name of Parts	Qty.
1	Closer Body	1
2	Main Arm	1
3	Forearm and Arm Shoe	1
4	Forearm Connecting Screw & Lockwasher	1
5	Forearm Connecting Washer	1
6	Oval Head Sheet Metal Screw, #12 X 1-1/2"	4
7	Oval Head Machine Screw, 12-24 X 3/4"	4
8	Truss Head Sheet Metal Screw, #12 X 1-1/4"	2
9	Truss Head Machine Screw, 12-24 X 3/4"	2
10	Closer Body Cover	1
11	Main Arm Connecting Screw & Lockwasher	1
12	Main Arm Flat Washer	1

FOR WOOD OR METAL		FOR METAL ONLY	
	← For Closer Body →		
(6)		(7)	
	← For Arm Shoe →		
(8)		(9)	

2. LOCATION OF CLOSER ON THE DOOR

Determine whether the door is left or right hand using the following illustrations. Remember that the CLOSER is always mounted inside the building near the hinge edge of the door.

2A. INWARD OPENING DOOR

This illustration shows the mounting for inward opening doors, as seen from inside the building.

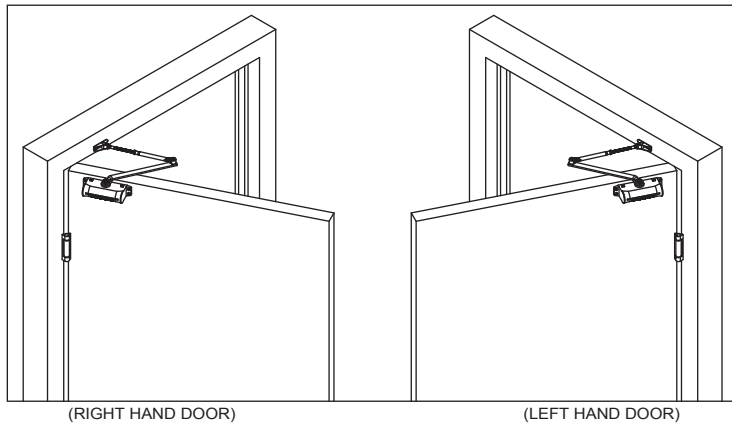

2B. OUTWARD OPENING DOOR

This illustration shows the mounting for outward opening doors, as seen from inside the building.

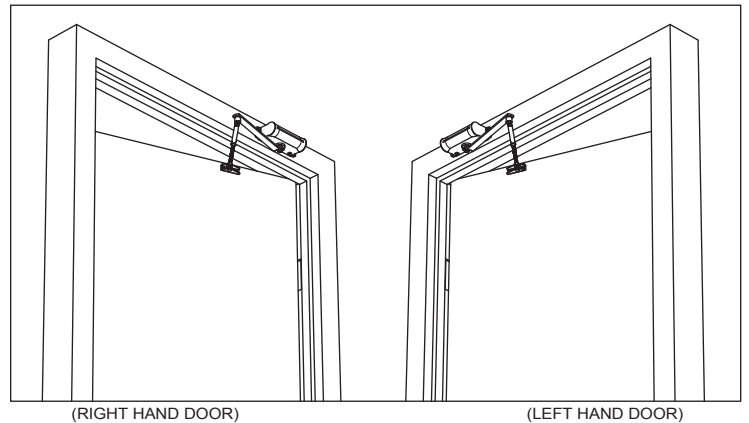

3-4. INSTALLATION PROCEDURE

3A. POSITIONING TEMPLATE

Templates to help position the CLOSER correctly are provided on an enclosed sheet, BE SURE TO USE CORRECT TEMPLATE. Decide the maximum opening angle for the door (120° or 155°) before cutting out the template. The template must be cut differently for each angle.

INWARD OPENING DOORS

Cut out the right or left hand template marked "INWARD OPENING". Tape the template to the upper edge of the door on the hinge side, as shown in the following illustration.

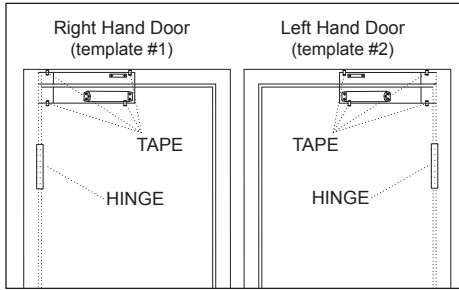

3B. MARKING HOLE LOCATION

Use a hammer and punch to mark the center of each screw hole then remove the template.

3C. PREPARING SCREW HOLES

NOTE: Numbers in parentheses () indicate the item number shown in Parts and Assembly Diagram on the front of this sheet.

3D. FASTENER OPTIONS

For hollow metal doors, machine screws are recommended, but sheet metal screws can be used as an alternative.

OUTWARD OPENING DOORS*

The templates are in two parts. Cut out the right or left hand templates marked "OUTWARD OPENING". Tape the shoe template on the door so that the heavy horizontal line is at the top edge of the door, and the heavy vertical line is along the hinge edge of the door. Tape the body template to the top door jamb so that the heavy horizontal line is along the bottom edge of the top door jamb and the vertical heavy line is directly above the shoe template heavy vertical line.

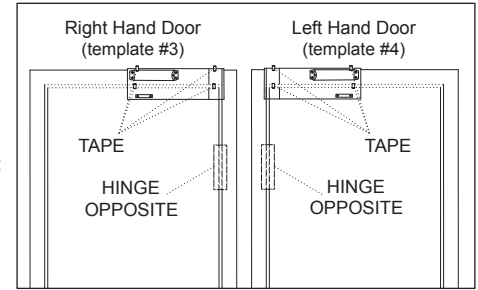

HOLE PREPARATION FOR FASTENERS				
FASTENERS	DOOR OR FRAME	DRILL SIZES	WHERE USED	DRILL DEPTH
12-24 Machine Screws	Hollow Metal	#16 (.177") Drill Bit & 12-24 Tap	Closer Body & Arm Shoe	5/8"
OR		OR		
#12 Sheet Metal Screws		3/16" Drill Bit		
#12 Sheet Metal Screws	Soft Wood	1/8" Drill Bit	Closer Body & Arm Shoe	1-1/4"
	Hard Wood	5/32" Drill Bit		

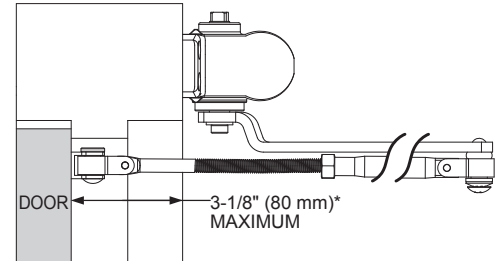

4A. ATTACHING ARM TO BODY

NOTE: Speed adjust valve on closer body (1) must be positioned towards the door hinge. Place arm (2) onto the TOP spindle of the closer body (1) for an inward opening door. Attach with screw (11) and flat washer (12).

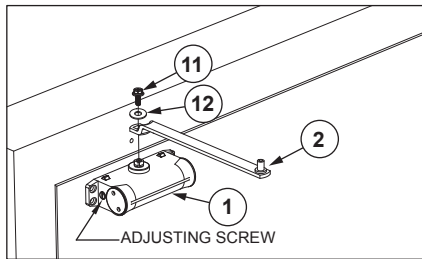

4B. ATTACHING BODY

Position body (1) with arm (2) attached over the drill holes on the door. Spindle with arm attached must be on the top. Fasten to door with four screws for wood (6), or four screws for aluminum or steel doors (6) or (7).

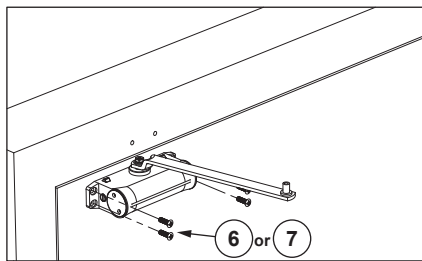

4C. ATTACHING FOREARM SHOE AND LINK ASSEMBLY

Position the forearm shoe (3) over holes on the door top jamb and fasten with two screws (8) for wood or two screws (8) or (9) for aluminum or steel doors.

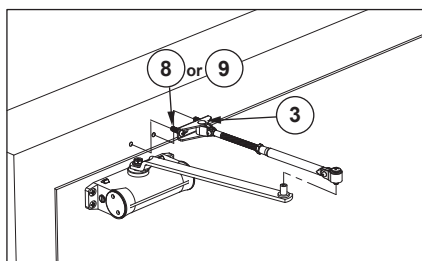

4D. CONNECTING ARM TO FOREARM

Adjust length of forearm to position the forearm at a right angle to frame, when connected to main arm at the elbow. Use washers (5) and screw (4) provided to secure the pivot connection. Tighten forearm locknut.

Important: When door is fully closed and the forearm is at a 90 degree angle to the door, this position creates pressure, which forces the door closed.

4E. SPEED ADJUSTMENT

Closer speed is factory set. If a different speed is desired, speed can be adjusted by a single screw adjustment. Turn speed adjustment screw clockwise for a slower speed and counter clockwise for a faster speed. Do not exceed two turns in either direction.

4F. ATTACH COVER

Slide cover (10) onto body (1). This completes the installation.

ATTENTION: ADJUST CLOSING SPEED TIME TO BETWEEN 4 & 6 SECONDS FROM 90°. USE OF THE DOOR BY HANDICAPPED, ELDERLY, OR SMALL CHILDREN MAY REQUIRE LONGER CLOSING TIMES.

4A. ATTACHING ARM TO BODY

NOTE: Speed adjust valve on closer body (1) must be positioned towards the door hinge. Place arm (2) onto the BOTTOM spindle of the closer body (1) for an outward opening door. Attach with screw (11) and flat washer (12).

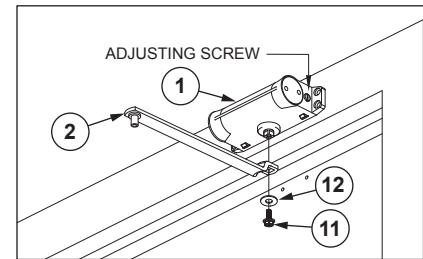

4B. ATTACHING BODY

Position body (1) with arm (2) attached over the drill holes on the jamb. Spindle with arm attached must be on the bottom. Fasten to door with four screws for wood (6), or four screws for aluminum or steel doors (6) or (7).

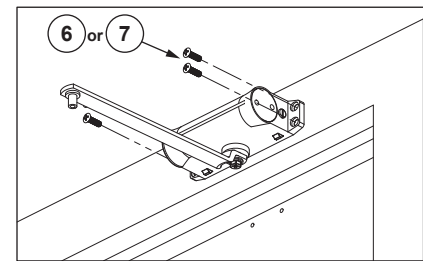

4C. ATTACHING FOREARM SHOE AND LINK ASSEMBLY

Position the forearm shoe (3) over holes on the door and fasten with two screws (8) for wood or two screws (8) or (9) for aluminum or steel doors.

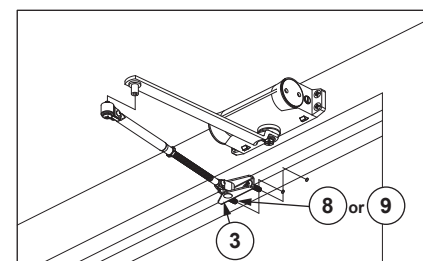

ADJUSTING LENGTH OF FOREARM

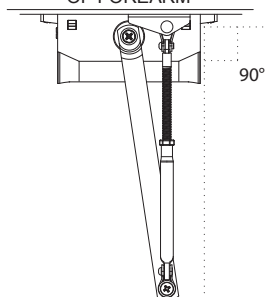

CLOSING SPEED CONTROL

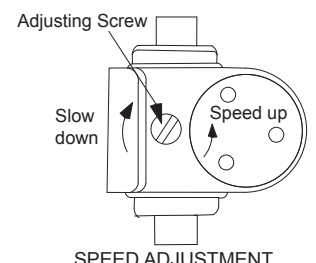

SPEED ADJUSTMENT

CAUTION: DO NOT BACK VALVES OUT OF CLOSER OR LEAK WILL RESULT.