

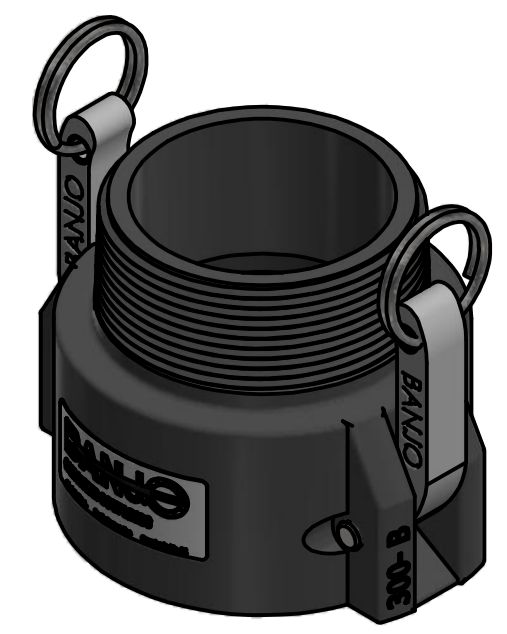

PARTS LIST			
ITEM	QTY	PART NUMBER	DESCRIPTION
1	1	150(200)D	CAM LEVER COUPLING DECAL
2	1	300G	3" Coupling Gasket
3	2	300K	CAM ARM
4	2	300P	CAM ARM PIN
5	1	300XB	3" FML COUPLE X 3" MALE NPT

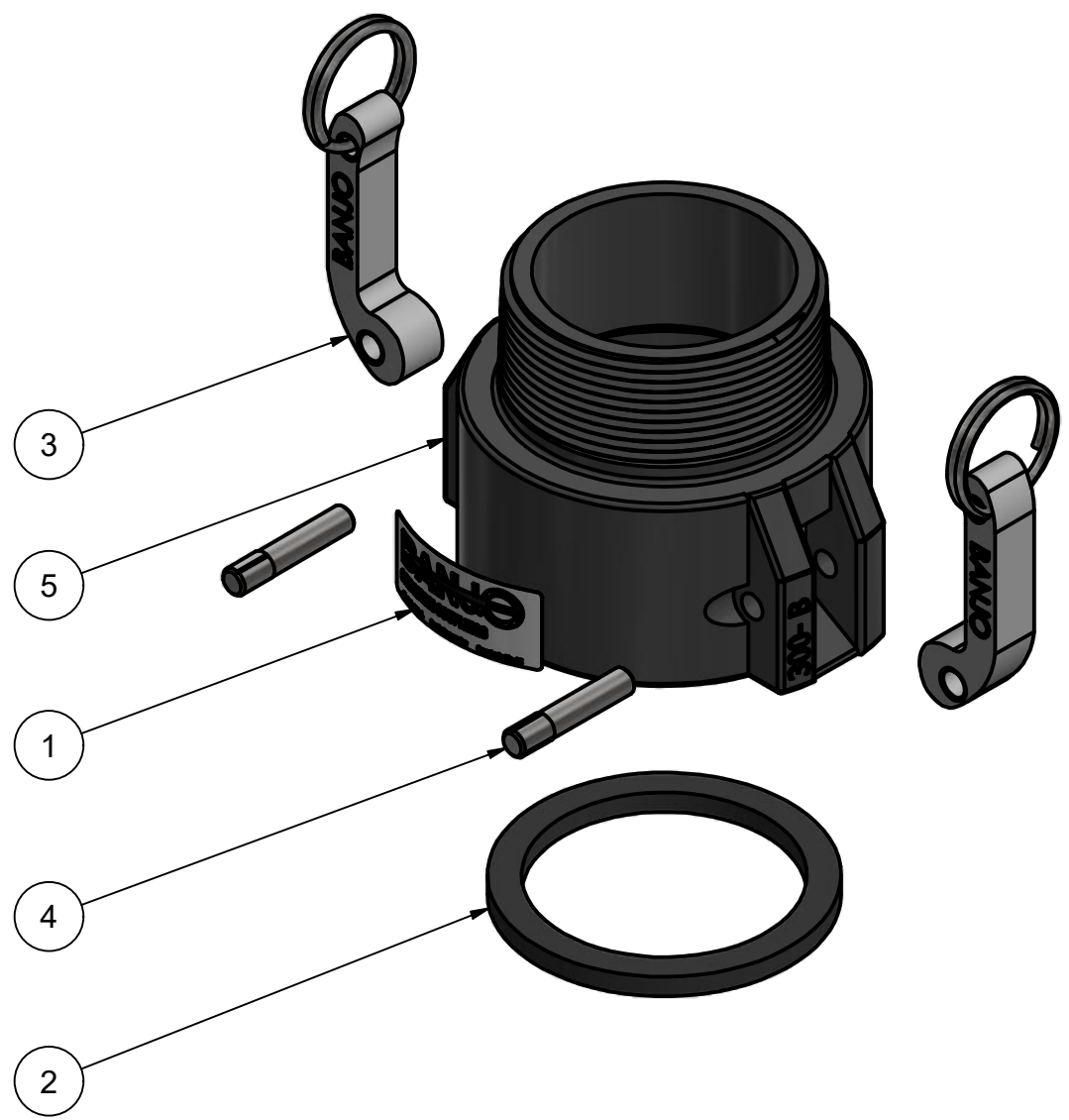

THIS DRAWING AND ALL INFORMATION CONTAINED THEREON ARE THE EXCLUSIVE PROPERTY OF BANJO CORPORATION.

UNLESS SPECIFICALLY NOTED, THIS DRAWING AND ITEMS SHOWN ON THIS DRAWING ARE SUBJECT TO CHANGE AT ANY TIME.



BANJO CORPORATION

150 BANJO DRIVE, CRAWFORDSVILLE, IN 47933
 WEB SITE: WWW.BANJOCORP.COM
 E-MAIL: BANJOSALES@IDEXCORP.COM

DESCRIPTION	FEMALE COUPLER 3" MALE THREAD
PART NUMBER	300B