

Parts List			
ITEM	QTY	PART NUMBER	DESCRIPTION
1	1	LS150-G	#339 O-RING
2	1	LS150-B	1 1/2" LINE STRAINER BODY
3	1	LS150-C	LS CAP ASSY
4	1	LS220	2" LS SCREEN - 20 MESH

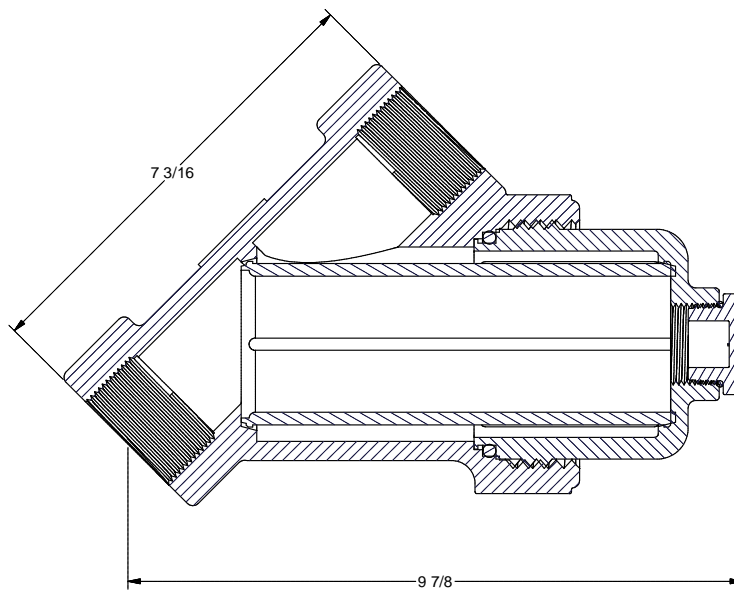

*NOTE:
ADDITIONAL CLEARANCE REQ'D
FOR SCREEN REMOVAL: 7"

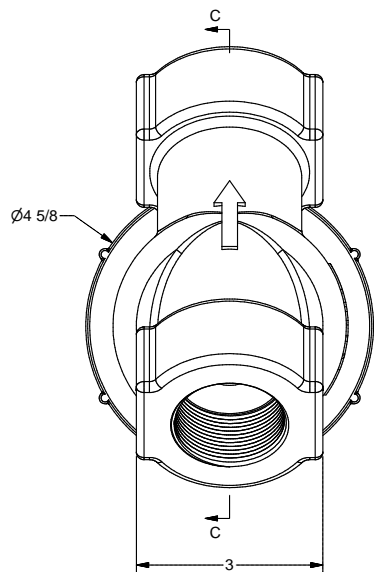
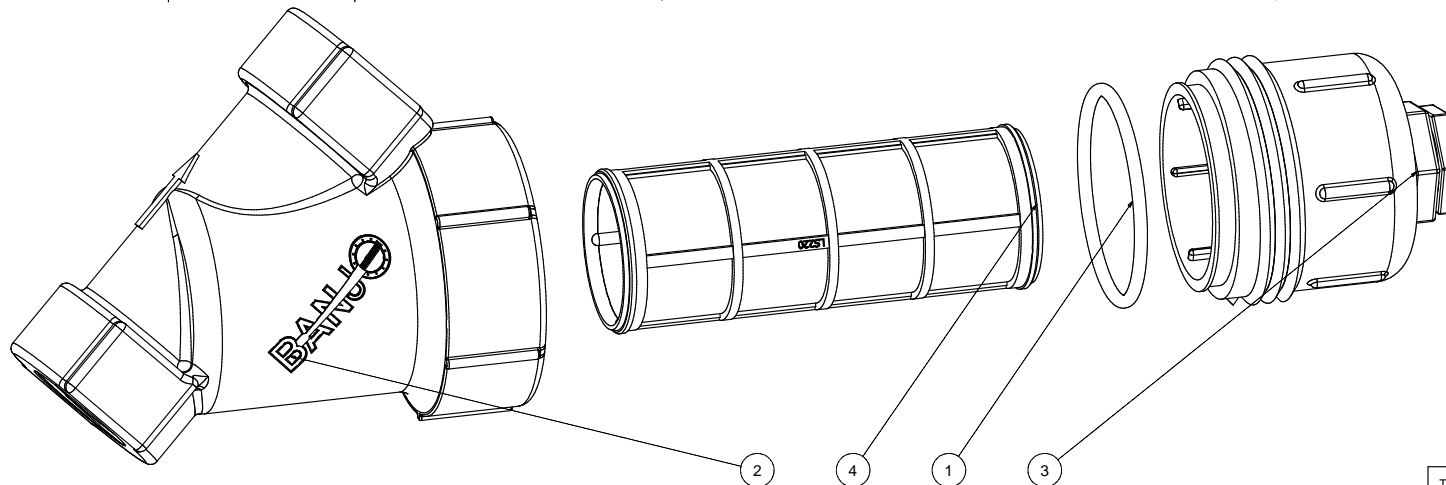

BANJO CORPORATION
150 BANJO DRIVE, CRAWFORDSVILLE, IN 47933
WEB SITE: WWW.BANJOCORP.COM
E-MAIL: SALES1@BANJOCORP.COM

THIS DRAWING AND ALL INFORMATION CONTAINED THEREON ARE THE EXCLUSIVE PROPERTY OF BANJO CORPORATION.

UNLESS SPECIFICALLY NOTED, THIS DRAWING AND ITEMS SHOWN ON THIS DRAWING ARE SUBJECT TO CHANGE AT ANY TIME.

DESCRIPTION
1 1/2" LINE STRAINERW/ #20 MESH
PART NUMBER
LS150-20