



2018

CATALOG & PARTS BOOK

THE BEST BUILT LAWN & GARDEN
PRODUCTS IN AMERICA. PERIOD.



VISIT US ONLINE @
WWW.FIMCOINDUSTRIES.COM

605.232.6800

AVAILABLE SPRAYER OPTIONS

PUMPS



1.0 GPM
HIGH-FLO 12V PUMP



2.1 GPM
HIGH-FLO 12V PUMP



3.8 GPM
HIGH-FLO 12V PUMP



2.2 GPM
PRO-SERIES 12V PUMP



4.0 GPM
PRO-SERIES 12V PUMP

HANDGUNS



**LEVER
HANDGUN**



**PISTOL GRIP
HANDGUN**



**ALUMINUM
HANDGUN**



**PRO SERIES LONG
RANGE HANDGUN**

SPRAY TIPS



**PREMIUM WIDE
ANGLE SPRAY TIPS**
INCLUDES NEW
ANTI-DRIP STRAINER



**PREMIUM AIR
INDUCTED SPRAY TIPS**
INCLUDES NEW
ANTI-DRIP STRAINER



**PREMIUM AIR
INDUCTED SPRAY TIPS**
INCLUDES CHEMSAVER
DRIP-FREE SHUT OFF

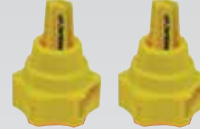

**XTENDER
TIPS**
INCLUDES DRIP-FREE
SHUT OFF VALVES



**XTENDER TIPS
& CENTER TIP**
INCLUDES DRIP-FREE
SHUT OFF VALVES

BOOMS & SPRAY COVERAGES



2-NOZZLE
80" SPRAY COVERAGE



4-NOZZLE
120" SPRAY COVERAGE



5-NOZZLE
100" SPRAY COVERAGE



7-NOZZLE
140" SPRAY COVERAGE



7-NOZZLE - DELUXE
140" SPRAY COVERAGE



2-NOZZLE BOOMLESS
28' SPRAY COVERAGE



3-NOZZLE BOOMLESS
30' SPRAY COVERAGE

LIDS



**STANDARD
5" FILL LID**



**PROFESSIONAL
MULTI-LID**

LEAD WIRES



8' 16 GAUGE LEAD WIRE
WITH QUICK COUPLER, IN-LINE
SWITCH & DELUXE BATTERY CLIPS



10' 14 GAUGE LEAD WIRE
WITH QUICK COUPLER, IN-LINE
SWITCH & DELUXE BATTERY CLIPS

MULTI-LID



- Food grade, 32 ounce measuring cup is attached to tank lid (You no longer have to search for a container)
- Garden hose port secures hose for safe and easy filling with one person
- Fits sprayers with a 5" tank lid
- Made in the USA

Model #	Code #	Carton Size	Shipping Class	UPS Able	UPC Code	List Price
Multi-Lid	7772014	7" x 7" x 7.5"	85	2#	733029113665	\$ 31.99

12 VOLT ON/OFF WIRELESS REMOTE CONTROL CONTROLS ALL 12 VOLT PRODUCTS UP TO 20 AMPS!



FEATURES:

- Wireless Remote
- Convenient Keychain Clip
- 2-way, 2 Wire Flat Molded Connectors
- 16 Gauge Wire



Rear View
Showing
Power In
and Power
Out Hookups



Collapsible Antenna
& Button Cover

Model #	Description	UPC Code	Part Size	List Price
7771938	12 Volt On/Off Wireless Remote Control	733029103536	4.25" x 7"	\$ 34.28



SPRAYER TANK NEUTRALIZER & CLEANER

Fimco's Tank Neutralizer cleaning agent is specifically designed to clean sprayers. Removes dirt, scale and rust from spray booms and tanks, as well as neutralizing the chemical action of spray chemicals previously used in this equipment. A completely soluble powder.

Recommended to be used for flushing sprayers after each timed use. Reduces corrosion in tanks and pumps.

Code #	Description	List Price
5173029	2 lb. Can (Packed 12 per Case)	\$ 36.00

PRO SERIES SPRAYER LINEUP



MODEL NUMBER (PART NUMBER - CATALOG PAGE)	LG-25-PRO (5302922 - PAGE 5)	ATV-25-700-PRO (5302927 - PAGE 6)	LG-3025-PRO (5302926 - PAGE 7)
TANK SIZE			
- 25 Gallons	X	X	X
- 40 Gallons			
- 50 Gallons			
PUMP SIZE (GPM)			
- Pro Series High-Flo 2.2 GPM	X		
- Pro Series High-Flo 4.0 GPM		X	X
PRESSURE (PSI)			
- 100 PSI	X		
- 45 PSI		X	X
MANIFOLD			
- Unit Utilizes Manifold System		X	X
PRESSURE GAUGE			
- 2 1/2" Liquid Filled Gauge		X	X
HANDGUN TYPE			
- Pro Series Handgun, 13" Aluminum	X	X	X
- Pro Series Handgun, 22" Aluminum			
HANDGUN SPRAY DISTANCE			
- 38' Horizontal & 27' Vertical	X	X	X
HANDGUN HOSE LENGTH			
- 25' of 3/8"	X	X	X
HANDGUN HOLDER			
- Pro Series Holder	X	X	X
- Horn Hose Wrap			
SPRAY TIPS			
- AIXR Air Inducted Tip		X	
- XTender End Tips & Center Tip			X
NUMBER OF BOOM NOZZLES			
- 3			X
- 4			
- 7		X	
BOOM SPRAY COVERAGE			
- 120" Coverage			
- 140" Coverage		X	
- 30' Coverage			X
BOOM TYPE			
- 3-Section Folding Boom		X	
- Wet Boom			X
QUICK RELEASE BOOM			
- Unit Utilizes Quick Release Boom		X	X
TIRE SIZE / TYPE			
- 18 x 8.50 - 8 Tire; 1" Axle			
3 POINT HITCH TYPE			
- Category 1			
LEAD WIRE			
- 10' 14 Gauge Heavy Duty Lead Wire	X	X	X
FILLING LID			
- Multi-Lid	X	X	X

PRO SERIES SPRAYER LINEUP



MODEL NUMBER (PART NUMBER - CATALOG PAGE)	LG-40-3PT-PRO (5302929 - PAGE 8)	LG-50-TRL-PRO (5302928 - PAGE 9)	LG-50-TRL-PRO-BL (5302930 - PAGE 9)
TANK SIZE			
- 25 Gallons			
- 40 Gallons	X		
- 50 Gallons		X	X
PUMP SIZE (GPM)			
- Pro Series High-Flo 2.2 GPM	X		
- Pro Series High-Flo 4.0 GPM		X	X
PRESSURE (PSI)			
- 100 PSI	X		
- 45 PSI		X	X
MANIFOLD			
- Unit Utilizes Manifold System	X	X	X
PRESSURE GAUGE			
- 2 1/2" Liquid Filled Gauge	X	X	X
HANDGUN TYPE			
- Pro Series Handgun, 13" Aluminum			
- Pro Series Handgun, 22" Aluminum	X	X	X
HANDGUN SPRAY DISTANCE			
- 38' Horizontal & 27' Vertical	X	X	X
HANDGUN HOSE LENGTH			
- 25' of 3/8"	X	X	X
HANDGUN HOLDER			
- Pro Series Holder	X		
- Horn Hose Wrap		X	X
SPRAY TIPS			
- AIXR Air Induced Tip	X	X	
- XTender End Tips & Center Tip			X
NUMBER OF BOOM NOZZLES			
- 3			X
- 4	X		
- 7		X	
BOOM SPRAY COVERAGE			
- 120" Coverage	X		
- 140" Coverage		X	
- 30' Coverage			X
BOOM TYPE			
- 3-Section Folding Boom	X	X	
- Wet Boom			X
QUICK RELEASE BOOM			
- Unit Utilizes Quick Release Boom			
TIRE SIZE / TYPE			
- 18 x 8.50 - 8 Tire; 1" Axle		X	X
3 POINT HITCH TYPE			
- Category 1	X		
LEAD WIRE			
- 10' 14 Gauge Heavy Duty Lead Wire	X	X	X
FILLING LID			
- Multi-Lid	X	X	X

PROFESSIONAL GRADE SPRAYERS

WHAT MAKES OUR NEW **PRO SERIES** THE BEST SPRAYERS ON THE MARKET TODAY?

UPGRADED PUMPS



HFP-2.2 G.P.M. & HFP-4.0 G.P.M.



- High-Flo 12 Volt Pro Series Pump; 2.2 GPM & 4.0 GPM
- Professional Grade Pump Upgraded Elastomers Is Ideal For:
 - Harsh Chemicals
 - Oil Based Chemicals With Surfactants

- Heavy Duty Motor
- 2.2 GPM - 1/2" MNPT Straight
- 4.0 GPM - 1/2" MNPT Straight
- **DO NOT USE with Flammable or Combustible Liquids**

LONG RANGE HANDGUNS



22" Pro Series



13" Pro Series

- 22" or 13" Aluminum Barrel
- Handgun Delivers:
 - 38' Max Horizontal Spray
 - 27' Max Vertical Spray

- 1/2" FNPT Inlet
- Easy Pull Trigger Handle
- Ergonomic Handgun Design
- Adjustable On/Off Trigger Stop

- Integrated Trigger Lock
- No Drip Shut Off
- Adjustable Spray Pattern
- .09375 Orifice Disc (3/32)

MULTI-LID



- Food grade, 32 ounce measuring cup is attached to tank lid. (You no longer have to search for a container)
- Garden hose port secures hose for safe and easy filling with one person
- Fits sprayers with a 5" tank lid
- Made in the USA

HEAVY DUTY LEAD WIRES



- 10' HEAVY DUTY 14 GAUGE LEAD WIRE
- WITH QUICK COUPLER, IN-LINE SWITCH & DELUXE BATTERY CLIPS

PRO SERIES SPOT SPRAYER

25 Gallon Poly Tank

Multi-Lid: To Accurately Measure & Pour Chemicals

Bowl Strainer

Pro Series High-Flo 2.2 GPM Demand Pump With 100 PSI Max Pressure

Long Range 13" Pro Series Handgun With Integrated Trigger Lock Delivers 38' Horizontal & 27' Vertical Spray

25' Of 3/8" Hose

10' 14 Gauge Lead Wire With Quick Coupler, In-Line Switch & Deluxe Battery Clips

LG-25-PRO

PROFESSIONAL GRADE PUMP

10 FT 14 GAUGE LEAD WIRE



Ratchet Straps NOT Included



2.2 GPM | **PRO SERIES**

Professional Grade Pump With Upgraded Elastomers Is Ideal For:

- Harsh Chemicals
- Oil Based Chemicals With Surfactants



With Quick Coupler, In-Line On/Off Switch & Deluxe Battery Clips



LG-25-PRO

Sprayer Weight	Water Weight	Sprayer W/Water Weight
23 lbs	209 lbs	232 lbs

Model #	Code #	Tank Size	Shipping Weight	Carton Size	Shipping Class	Cubic Feet	UPS Able	UPC Code	List Price
LG-25-PRO	5302922	25 Gallon	-	32 x 15 x 20	150	5.7	YES	733029116864	\$ 473.00

PRO SERIES 7-NOZZLE ATV SPRAYER

PRO SERIES SPRAYERS
UTV SPRAYERS
SPOT SPRAYERS
ATV SPRAYERS
TRAILER SPRAYERS
UTILITY & 3PT SPRAYERS
SMID SPRAYERS & BOOMS
PUMPS
SPRAYER ACCESSORIES
DRY MATERIAL SPREADERS
TRAILER CARTS & AERATORS
SPRAYER COMPONENTS
PARTS/ST BREAKDOWNS

25 Gallon Poly Tank

Pro Series High-Flo 4.0 GPM Demand Pump With 45 PSI Max Pressure

Innovative Manifold With On/Off Valves For Pressure/Control & Boom Operation

Multi-Lid: To Accurately Measure & Pour Chemicals

Bowl Strainer

2 1/2" Liquid Filled Gauge

Long Range 13" Pro Series Handgun With Integrated Trigger Lock Delivers 38' Horizontal & 27' Vertical Spray

10' 14 Gauge Lead Wire With Quick Coupler, In-Line Switch & Deluxe Battery Clips

25' Of 3/8" Hose

7 Nozzle, 3 Section Folding Boom - 140" Spray Coverage

Quick Release Feature Allows Operator To Quickly Install / Remove Spray Boom To Convert From Spot To ATV Sprayer

ATV-25-700-PRO

INNOVATIVE MANIFOLD

SPRAY TIPS & BOOM PATTERN



AIXR PREMIUM AIR INDUCED
INCLUDES NEW ANTI-DRIP STRAINER

7-NOZZLE BOOM SPRAY PATTERN (140")

ATV-25-700-PRO



Sprayer Weight	Water Weight	Sprayer W/Water Weight
56 lbs	209 lbs	265 lbs

Model #	Code #	Tank Size	Shipping Weight	Carton Size	Shipping Class	Cubic Feet	UPS Able	UPC Code	List Price
ATV-25-700-PRO	5302927	25 Gallon	-	56 x 15 x 26	150	12.7	No	733029117434	\$ 766.00

PRO SERIES BOOMLESS ATV SPRAYER

25 Gallon Poly Tank

Pro Series High-Flo 4.0 GPM Demand Pump With 45 PSI Max Pressure

Innovative Manifold With On/Off Valves For Pressure/Control & Boom Operation

Multi-Lid: To Accurately Measure & Pour Chemicals

Bowl Strainer

2 1/2" Liquid Filled Gauge

Long Range 13" Pro Series Handgun With Integrated Trigger Lock Delivers 38' Horizontal & 27' Vertical Spray

10' 14 Gauge Lead Wire With Quick Coupler, In-Line Switch & Deluxe Battery Clips

25' Of 3/8" Hose

All 3 Nozzles Have Built-In Drip Free Shutoff Valves To Spray From 6 Feet To 30 Feet Spray Coverage

Quick Release Feature Allows Operator To Quickly Install / Remove Spray Boom To Convert From Spot To ATV Sprayer

LG-3025-PRO

INNOVATIVE MANIFOLD

SPRAY TIPS & BOOM PATTERN



XTENDER TIPS & CENTER TIP
INCLUDES DRIP FREE SHUT OFF VALVES



BOOMLESS NOZZLE SPRAY PATTERN (30')

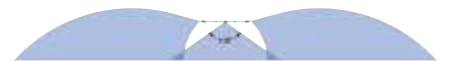

LG-3025-PRO



Sprayer Weight	Water Weight	Sprayer W/Water Weight
35 lbs	209 lbs	244 lbs

Model #	Code #	Tank Size	Shipping Weight	Carton Size	Shipping Class	Cubic Feet	UPS Able	UPC Code	List Price
LG-3025-PRO	5302926	25 Gallon	-	38 x 15 x 20	150	6.6	Yes	733029117427	\$ 897.00

PRO SERIES SPRAYERS
UTV SPRAYERS
SPOT SPRAYERS
ATV SPRAYERS
TRAILER SPRAYERS
UTILITY & 3PT SPRAYERS
SKID SPRAYERS & BOOMS
PUMPS
SPRAYER ACCESSORIES
DRY MATERIAL SPREADERS
TRAILER CARTS & AERATORS
SPRAYER COMPONENTS
PARTSLIST BREAKDOWNS

PRO SERIES SPRAYERS
 UTV SPRAYERS
 SPOT SPRAYERS
 ATV SPRAYERS
 TRAILER SPRAYERS
 UTILITY & 3PT SPRAYERS
 SMID SPRAYERS & BOOMS
 PUMPS
 SPRAYER ACCESSORIES
 DRY MATERIAL SPREADERS
 TRAILER CARTS & AERATORS
 SPRAYER COMPONENTS
 PARTS/LIST BREAKDOWNS

PRO SERIES 3PT SPRAYER

40 Gallon Poly Tank

2 1/2" Liquid Filled Gauge

Multi-Lid: To Accurately Measure & Pour Chemicals

Innovative Manifold With On/Off Valves For Pressure/Control & Boom Operation

Bowl Strainer

Long Range 22" Pro Series Handgun With Integrated Trigger Lock Delivers 38' Horizontal & 27' Vertical Spray

Pro Series High-Flo 2.2 GPM Demand Pump With 100 PSI Max Pressure

25' Of 3/8" Hose

Category 1 3 Point Hitch

4 Nozzle, 3 Section Folding Boom - 120" Spray Coverage

10' 14 Gauge Lead Wire With Quick Coupler, In-Line Switch & Deluxe Battery Clips

LG-40-3PT-PRO

INNOVATIVE MANIFOLD

SPRAY TIPS & BOOM PATTERN



LG-40-3PT-PRO



Sprayer Weight	Water Weight	Sprayer W/Water Weight
80 lbs	334 lbs	414 lbs

Model #	Code #	Tank Size	Shipping Weight	Carton Size	Shipping Class	Cubic Feet	UPS Able	UPC Code	List Price
LG-40-3PT-PRO	5302929	40 Gallon	90#	40 x 24 x 24	150	13.4	139#	733029117458	\$ 1,071.00

PRO SERIES TRAILER SPRAYERS

PRO SERIES
SPRAYERS

UTV
SPRAYERS

SPOT
SPRAYERS

ATV
SPRAYERS

TRAILER
SPRAYERS

UTILITY &
3PT SPRAYERS

SKID SPRAYERS
& BOOMS

PUMPS

SPRAYER
ACCESSORIES

DRY MATERIAL
SPREADERS

TRAILER CARTS
& AERATORS

SPRAYER
COMPONENTS

PARTSLIST
BREAKDOWNS

50 Gallon
Poly Tank

Multi-Lid: To Accurately
Measure & Pour Chemicals

Long Range 22" Pro Series Handgun
With Integrated Trigger Lock Delivers
38' Horizontal & 27' Vertical Spray

25' Of
3/8" Hose

Innovative Manifold
With On/Off Valves
For Pressure/Control
& Boom Operation

2 1/2" Liquid
Filled Gauge

7 Nozzle,
3 Section
Folding Boom
- 140" Spray
Coverage

18 x 8.50 - 8 Tire
1" Axle

10' 14 Gauge Lead Wire With
Quick Coupler, In-Line Switch
& Deluxe Battery Clips

Pro Series High-Flo
4.0 GPM Demand Pump
With 45 PSI Max Pressure

LG-50-TRL-PRO

INNOVATIVE MANIFOLD

SPRAY TIPS & BOOM PATTERN

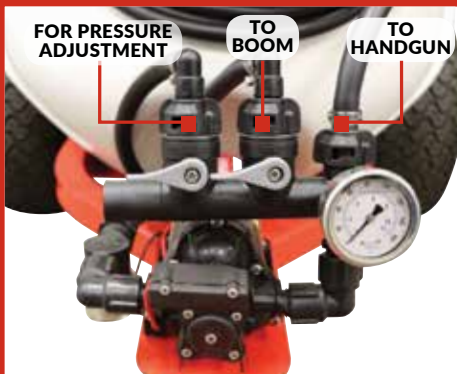

AIXR PREMIUM AIR INDUCED
INCLUDES NEW ANTI-DRIP STRAINER

7-NOZZLE BOOM SPRAY PATTERN (140")

XTENDER TIPS & CENTER TIP
INCLUDES DRIP FREE SHUT OFF VALVES

BOOMLESS NOZZLE SPRAY PATTERN (30")

LG-50-TRL-PRO & LG-50-TRL-PRO-BL



Sprayer Weight	Water Weight	Sprayer W/Water Weight
180 lbs	417 lbs	597 lbs

Model #	Code #	Tank Size	Shipping Weight	Carton Size	Shipping Class	Cubic Feet	UPS Able	UPC Code	List Price
LG-50-TRL-PRO	5302928	50 Gallon	-	55 x 41 x 28	150	36.6	No	733029117441	\$ 1,495.00
LG-50-TRL-PRO-BL	5302930	50 Gallon	-	55 x 41 x 28	150	36.6	No	733029117571	\$ 1,433.00

UTV SPRAYER LINEUP



MODEL NUMBER (PART NUMBER - CATALOG PAGE)	UTV-45-7 (5302864 - PAGE 12)	UTV-45-BL (5302865 - PAGE 12)	UTV-65-7 (5302830 - PAGE 13)	UTV-65-BL (5302843 - PAGE 13)
TANK SIZE				
- 45 Gallons	X	X		
- 65 Gallons			X	X
PUMP SIZE (GPM)				
- High-Flo 3.8 GPM	X	X	X	X
PRESSURE (PSI)				
- 45 PSI	X	X	X	X
MANIFOLD				
- Unit Utilizes SDManifold System	X	X	X	X
PRESSURE GAUGE				
- 2" Dry 100 Back Mount	X	X	X	X
HANDGUN TYPE				
- Pistol Grip Handgun With X-26 Tip	X	X	X	X
HANDGUN SPRAY DISTANCE				
- 35' Horizontal & 26' Vertical	X	X	X	X
HANDGUN HOSE LENGTH				
- 25' of 3/8"	X	X	X	X
HANDGUN HOLDER				
- Horn Hose Wrap	X	X	X	X
SPRAY TIPS				
- AIXR Air Inducted Tip	X		X	
- XTender End Tips & Center Tip		X		X
NUMBER OF BOOM NOZZLES				
- 3		X		X
- 7	X		X	
BOOM SPRAY COVERAGE				
- 140" Coverage	X		X	
- 30' Coverage		X		X
BOOM TYPE				
- 3-Section Folding Boom	X		X	
- Wet Boom		X		X
EASY GRIP BOOM SYSTEM				
- Unit Utilizes Easy Grip System	X	X	X	X
LEAD WIRE				
- 8' 16 Gauge Lead Wire	X	X	X	X
FILLING LID				
- Multi-Lid	X	X	X	X



WHAT OPTIONS ARE AVAILABLE FOR YOUR UTV SPRAYER?



PRO SERIES SPRAYERS
UTV SPRAYERS
SPOT SPRAYERS
ATV SPRAYERS
TRAILER SPRAYERS
UTILITY & 3PT SPRAYERS
SKID SPRAYERS & BOOMS
PUMPS
SPRAYER ACCESSORIES
DRY MATERIAL SPREADERS
TRAILER CARTS & AERATORS
SPRAYER COMPONENTS
PARTSLIST BREAKDOWNS

HOSE REEL ATTACHMENT



INCLUDES 50' OF 3/8" HOSE
(UNIT AND BOOM NOT INCLUDED)

BOOM OPTIONS

7-NOZZLE, 3 SECTION (140")

AIXR
PREMIUM
AIR INDUCED
INCLUDES NEW
ANTI-DRIP
STRAINER



7-NOZZLE BOOM SPRAY PATTERN (140")



OR

3-NOZZLE BOOMLESS (30')

XTENDER TIPS
& CENTER TIP

INCLUDES DRIP FREE
SHUT OFF VALVES



BOOMLESS NOZZLE SPRAY PATTERN (30')

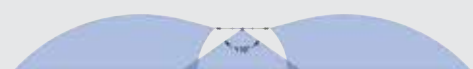

TANK DRY & WATER WEIGHTS

Product	Tank Size	Dry Sprayer Weight Without Spray Boom	Dry Sprayer Weight With Spray Boom	Total Sprayer Weight When Filled with Water
UTV-45-7	36" x 30"	46 lbs	81 lbs	465 lbs
UTV-45-BL	36" x 30"	46 lbs	66 lbs	450 lbs
UTV-65-7	47" x 34.5"	58 lbs	87 lbs	640 lbs
UTV-65-BL	47" x 34.5"	58 lbs	72 lbs	625 lbs

(UTV) UTILITY VEHICLE SPRAYERS

Innovative Manifold With On/Off Valves For Pressure/Control & Boom Operation

3.8 GPM High-Flo
12V Pump;
45 PSI; 11 Amp

Pistol Grip Handgun With 35' Horizontal & 26' Vertical Spray

25' Of
3/8" Hose

45 Gallon
Poly Tank

Multi-Lid:
To Accurately
Measure
& Pour
Chemicals



Easy Grip Boom Design Allows For Quick Install/
Removal Of Spray Boom And Saves Space For Storage

All 3 Nozzles Have Built-In Drip Free Shutoff
Valves To Spray From 6' To 30'

UTV-45-BL

UTV ACCESSORY

SPRAY TIPS & BOOM PATTERN



OPTIONAL
HOSE REEL
ATTACHMENT

INCLUDES
50' OF 3/8" HOSE



XTENDER TIPS & CENTER TIP

INCLUDES DRIP FREE
SHUT OFF VALVES



BOOMLESS NOZZLE SPRAY PATTERN (30')

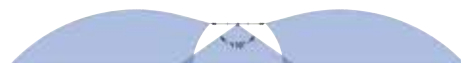

UTV-45-7 & UTV-45-BL

See Pages 168 & 169 For Exploded View & Parts List

Model #	Code #	Tank Size	Shipping Weight	Carton Size	Shipping Class	Cubic Feet	UPS Able	UPC Code	List Price
UTV-45-7	5302864	45 Gallon	130	37 x 31 x 19	150	12.7	NO	733029114839	\$ 1,045.00
UTV-45-BL	5302865	45 Gallon	125	37 x 31 x 19	150	12.7	NO	733029114822	\$ 985.00
UTV-HR-50	5302886	NA	46	34 x 16 x 14	85	4.8	49#	733029115003	\$ 324.00

(UTV) UTILITY VEHICLE SPRAYERS

Innovative Manifold With On/Off Valves For Pressure/Control & Boom Operation

3.8 GPM High-Flo
12V Pump;
45 PSI; 11 Amp

Pistol Grip Handgun With 35' Horizontal & 26' Vertical Spray

25' Of
3/8" Hose

65 Gallon
Poly Tank

Multi-Lid:
To Accurately
Measure
& Pour
Chemicals



Easy Grip Boom Design Allows For Quick Install/
Removal Of Spray Boom And Saves Space For Storage

7 Nozzle, 3 Section Folding Boom
- 140" Spray Coverage

UTV-65-7



UTV ACCESSORY

OPTIONAL
HOSE REEL
ATTACHMENT

INCLUDES
50' OF 3/8" HOSE



SPRAY TIPS & BOOM PATTERN

AIXR
PREMIUM
AIR INDUCED
INCLUDES NEW
ANTI-DRIP
STRAINER



7-NOZZLE BOOM SPRAY PATTERN (140")



UTV-65-7 & UTV-65-BL

See Pages 168 & 169 For Exploded View & Parts List

Model #	Code #	Tank Size	Shipping Weight	Carton Size	Shipping Class	Cubic Feet	UPS Able	UPC Code	List Price
UTV-65-7	5302830	65 Gallon	135	47 x 36 x 18	150	17.7	NO	733029114433	\$ 1,102.00
UTV-65-BL	5302843	65 Gallon	130	47 x 36 x 18	150	17.7	NO	733029114327	\$ 1,042.00
UTV-HR-50	5302886	NA	46	34 x 16 x 14	85	4.8	49#	733029115003	\$ 324.00

PRO SERIES SPRAYERS
UTV SPRAYERS
SPOT SPRAYERS
ATV SPRAYERS
TRAILER SPRAYERS
UTILITY & 3PT SPRAYERS
SKID SPRAYERS & BOOMS
PUMPS
SPRAYER ACCESSORIES
DRY MATERIAL SPREADERS
TRAILER CARTS & AERATORS
SPRAYER COMPONENTS
PARTSLIST BREAKDOWNS

SPOT SPRAYER LINEUP



MODEL NUMBER (PART NUMBER - CATALOG PAGE)	LG-*EC (PAGE 16)	LG-*P (PAGE 17)	LG-28-S (5301063 - PAGE 18)	LG-*PM (PAGE 19)
TANK SIZE				
- 10 Gallons	X			
- 15 Gallons	X	X		X
- 20 Gallons	X			
- 25 Gallons	X	X	X	X
- 40 Gallons				
PUMP SIZE (GPM)				
- High-Flo 1.0 GPM	X			
- High-Flo 2.1 GPM		X	X	X
- High-Flo 3.8 GPM				
PRESSURE (PSI)				
- 60 PSI		X	X	X
- 45 PSI				
- 35 PSI	X			
MANIFOLD				
- Unit Utilizes Manifold System				X
PRESSURE GAUGE				
- 2" Dry 100 PSI Pressure Gauge				X
HANDGUN TYPE				
- Lever Handgun With X-26 Poly Tip	X	X		X
- Pistol Grip Handgun With X-26 Brass Tip			X	
HANDGUN SPRAY DISTANCE				
- 25' Horizontal & 12' Vertical	X			
- 30' Horizontal & 15' Vertical		X		
- 35' Horizontal & 25' Vertical			X	X
- 35' Horizontal & 26' Vertical				
HANDGUN HOSE LENGTH				
- 15' of 3/8"	X	X	X	X
- 25' of 3/8"				
HANDGUN HOLDER				
- Molded Clips	X	X	X	X
LEAD WIRE				
- 96" Lead Wire	X	X	X	X
FILLING LID				
- 5" Standard	X	X	X	X
STEEL FRAME				
- For Full Drain Sumps				

SPOT SPRAYER LINEUP

PRO SERIES SPRAYERS
UTV SPRAYERS
SPOT SPRAYERS
ATV SPRAYERS
TRAILER SPRAYERS
UTILITY & 3PT SPRAYERS
SKID SPRAYERS & BOOMS
PUMPS
SPRAYER ACCESSORIES
DRY MATERIAL SPREADERS
TRAILER CARTS & AERATORS
SPRAYER COMPONENTS
PARTSLIST BREAKDOWNS



MODEL NUMBER (PART NUMBER - CATALOG PAGE)	LG-*SM (PAGE 20)	LG-25-HV (5301222 - PAGE 21)	LG-40-DLX (5302186 - PAGE 22)	LG-40-SS (5301335 - PAGE 23)
TANK SIZE				
- 10 Gallons				
- 15 Gallons	X			
- 20 Gallons				
- 25 Gallons	X	X		
- 40 Gallons			X	X
PUMP SIZE (GPM)				
- High-Flo 1.0 GPM				
- High-Flo 2.1 GPM	X		X	
- High-Flo 3.8 GPM		X		X
PRESSURE (PSI)				
- 60 PSI	X		X	
- 45 PSI		X		X
- 35 PSI				
MANIFOLD				
- Unit Utilizes Manifold System	X	X	X	
PRESSURE GAUGE				
- 2" Dry 100 PSI Pressure Gauge	X	X		
HANDGUN TYPE				
- Lever Handgun With X-26 Poly Tip				
- Pistol Grip Handgun With X-26 Brass Tip	X	X	X	X
HANDGUN SPRAY DISTANCE				
- 25' Horizontal & 12' Vertical				
- 30' Horizontal & 15' Vertical				
- 35' Horizontal & 25' Vertical	X		X	
- 35' Horizontal & 26' Vertical		X		X
HANDGUN HOSE LENGTH				
- 15' of 3/8"	X	X	X	
- 25' of 3/8"				X
HANDGUN HOLDER				
- Molded Clips	X	X	X	X
LEAD WIRE				
- 96" Lead Wire	X	X	X	X
FILLING LID				
- 5" Standard	X	X	X	X
STEEL FRAME				
- For Full Drain Sumps				X

ECONOMY SPOT SPRAYERS

10, 15, 20 Or 25 Gallon Poly Tank

Lever Handgun With 25' Horizontal & 12' Vertical Spray

1.0 GPM Demand Pump With 35 PSI Max Pressure

8' 16 Gauge Lead Wire With Quick Coupler, In-Line On/Off Switch & Deluxe Battery Clips

15' Of 3/8" Hose

LG-20-EC

HIGH-FLO PUMP

8' 16 GAUGE LEAD WIRE



1.0 GPM **HIGH FLO**

- 12 Volt Demand Pump
- 35 PSI Max
- 4 Amp



With Quick Coupler, In-Line On/Off Switch & Deluxe Battery Clips

LG-10-EC, LG-15-EC, LG-20-EC, & LG-25-EC

Sprayer Model	Sprayer Weight	Water Weight	Sprayer W/Water Weight
LG-10-EC	13 lbs	83 lbs	96 lbs
LG-15-EC	14 lbs	125 lbs	139 lbs
LG-20-EC	16 lbs	167 lbs	183 lbs
LG-25-EC	18 lbs	209 lbs	227 lbs

See Page 157 For Exploded View & Parts List

Model #	Code #	Tank Size	Shipping Weight	Carton Size	Shipping Class	Cubic Feet	UPS Able	UPC Code	List Price
LG-10-EC	5301547	10 Gallon	14	31 x 14 x 12	150	3.1	32#	733029005250	\$ 170.00
LG-15-EC	5301302	15 Gallon	15	34 x 16 x 14	150	4.5	46#	733029003058	\$ 181.00
LG-20-EC	5301548	20 Gallon	17	38 x 18 x 15	150	6.0	62#	733029005267	\$ 198.00
LG-25-EC	5301378	25 Gallon	20	40 x 19 x 16	150	7.1	74#	733029003195	\$ 209.00

STANDARD SPOT SPRAYERS

15 Or 25 Gallon Poly Tank

Lever Handgun With 30' Horizontal & 15' Vertical Spray

2.1 GPM Demand Pump With 60 PSI Max Pressure

8' 16 Gauge Lead Wire With Quick Coupler, In-Line On/Off Switch & Deluxe Battery Clips

15' Of 3/8" Hose



LG-29-P

HIGH-FLO PUMP

8' 16 GAUGE LEAD WIRE



Ratchet Straps NOT Included



2.1 GPM **HIGH FLO**

- 12 Volt Demand Pump
- 60 PSI Max
- 8 Amp



With Quick Coupler, In-Line On/Off Switch & Deluxe Battery Clips

Sprayer Model	Sprayer Weight	Water Weight	Sprayer W/Water Weight
LG-13-P	16 lbs	125 lbs	141 lbs
LG-29-P	20 lbs	209 lbs	229 lbs

LG-13-P & LG-29-P

Model #	Code #	Tank Size	Shipping Weight	Carton Size	Shipping Class	Cubic Feet	UPS Able	UPC Code	List Price
LG-13-P	5300393	15 Gallon	17	34 x 16 x 14	150	4.5	46#	733029001009	\$ 230.00
LG-29-P	5300632	25 Gallon	22	40 x 19 x 16	150	7.1	74#	733029001443	\$ 246.00

DELUXE SPOT SPRAYERS

25 Gallon Poly Tank

Pistol Grip Handgun With 35' Horizontal & 25' Vertical Spray



2.1 GPM Demand Pump With 60 PSI Max Pressure

8' 16 Gauge Lead Wire With Quick Coupler, In-Line On/Off Switch & Deluxe Battery Clips

15' Of 3/8" Hose

LG-28-S



Ratchet Straps NOT Included

HIGH-FLO PUMP



2.1 GPM **HIGH FLO**
 - 12 Volt Demand Pump
 - 60 PSI Max
 - 8 Amp

8' 16 GAUGE LEAD WIRE



With Quick Coupler, In-Line On/Off Switch & Deluxe Battery Clips

Sprayer Weight	Water Weight	Sprayer W/Water Weight
21 lbs	209 lbs	230 lbs

LG-28-S

Model #	Code #	Tank Size	Shipping Weight	Carton Size	Shipping Class	Cubic Feet	UPS Able	UPC Code	List Price
LG-28-S	5301063	25 Gallon	22	40 x 19 x 16	150	7.1	74#	733029002310	\$ 266.00

MANIFOLD SPOT SPRAYERS

15 Or 25 Gallon Poly Tank

Innovative Manifold With On/Off Valves For Pressure/Control & Boom Operation

Lever Handgun With 30' Horizontal & 15' Vertical Spray

2" Dry 100 PSI Pressure Gauge

15' Of 3/8" Hose

2.1 GPM Demand Pump With 60 PSI Max Pressure

8' 16 Gauge Lead Wire With Quick Coupler, In-Line On/Off Switch & Deluxe Battery Clips



LG-14-PM

INNOVATIVE MANIFOLD

HIGH-FLO PUMP

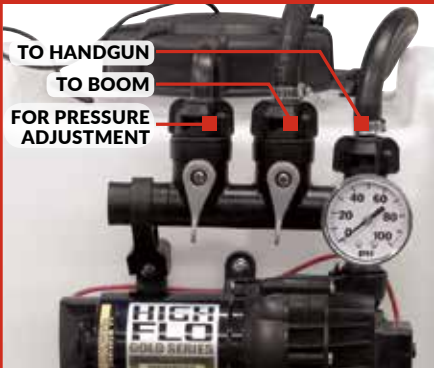

Sprayer Model	Sprayer Weight	Water Weight	Sprayer W/Water Weight
LG-14-PM	16 lbs	125 lbs	141 lbs
LG-25-PM	22 lbs	209 lbs	231 lbs

LG-14-PM & LG-25-PM

See Page 158 For Exploded View & Parts List

Model #	Code #	Tank Size	Shipping Weight	Carton Size	Shipping Class	Cubic Feet	UPS Able	UPC Code	List Price
LG-14-PM	5301144	15 Gallon	17	34 x 16 x 14	150	4.5	46#	733029002549	\$ 262.00
LG-25-PM	5301146	25 Gallon	23	40 x 19 x 16	150	7.1	74#	733029002563	\$ 274.00

PRO SERIES SPRAYERS
UTV SPRAYERS
SPOT SPRAYERS
ATV SPRAYERS
TRAILER SPRAYERS
UTILITY & 3PT SPRAYERS
SKID SPRAYERS & BOOMS
PUMPS
SPRAYER ACCESSORIES
DRY MATERIAL SPREADERS
TRAILER CARTS & AERATORS
SPRAYER COMPONENTS
PARTSLIST BREAKDOWNS

MANIFOLD SPOT SPRAYERS

15 Or 25 Gallon Poly Tank

Innovative Manifold With On/Off Valves For Pressure/Control & Boom Operation



Pistol Grip Handgun With 35' Horizontal & 25' Vertical Spray

2" Dry 100 PSI Pressure Gauge

2.1 GPM Demand Pump With 60 PSI Max Pressure

8' 16 Gauge Lead Wire With Quick Coupler, In-Line On/Off Switch & Deluxe Battery Clips

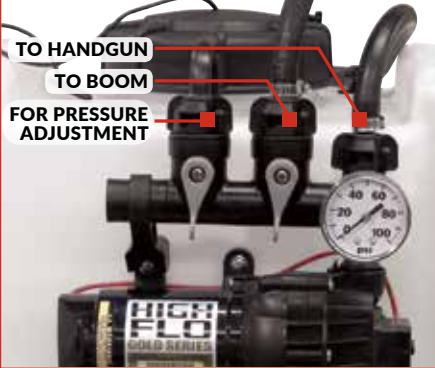
15' Of 3/8" Hose

LG-25-SM	INNOVATIVE MANIFOLD	HIGH-FLO PUMP
 <p>Ratchet Straps NOT Included</p>		 <p>2.1 GPM HIGH FLO</p> <ul style="list-style-type: none"> - 12 Volt Demand Pump - 60 PSI Max - 8 Amp

Sprayer Model	Sprayer Weight	Water Weight	Sprayer W/Water Weight
LG-14-SM	16 lbs	125 lbs	141 lbs
LG-25-SM	21 lbs	209 lbs	230 lbs

LG-14-SM & LG-25-SM

Model #	Code #	Tank Size	Shipping Weight	Carton Size	Shipping Class	Cubic Feet	UPS Able	UPC Code	List Price
LG-14-SM	5301145	15 Gallon	17	34 x 16 x 15	150	4.5	46#	733029002556	\$ 274.00
LG-25-SM	5301147	25 Gallon	23	40 x 19 x 16	150	7.1	74#	733029002570	\$ 293.00

DELUXE MANIFOLD SPOT SPRAYERS

25 Gallon Poly Tank

Innovative Manifold With On/Off Valves For Pressure/Control & Boom Operation

Pistol Grip Handgun With 35' Horizontal & 26' Vertical Spray

2" Dry 100 PSI Pressure Gauge

3.8 GPM Demand Pump With 45 PSI Max Pressure

8' 16 Gauge Lead Wire With Quick Coupler, In-Line On/Off Switch & Deluxe Battery Clips

15' Of 3/8" Hose

LG-25-HV

INNOVATIVE MANIFOLD

HIGH-FLO PUMP

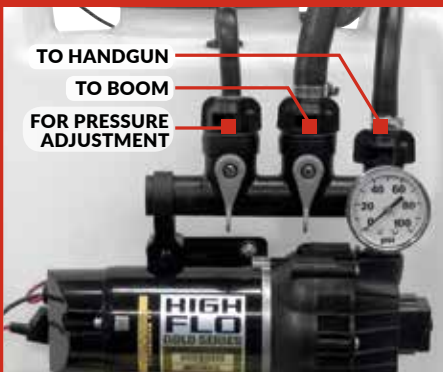

LG-25-HV

Sprayer Weight	Water Weight	Sprayer W/Water Weight
22 lbs	209 lbs	231 lbs

Model #	Code #	Tank Size	Shipping Weight	Carton Size	Shipping Class	Cubic Feet	UPS Able	UPC Code	List Price
LG-25-HV	5301222	25 Gallon	24	40 x 19 x 16	15#	7.1	74#	733029002990	\$ 330.00

PRO SERIES SPRAYERS
UTV SPRAYERS
SPOT SPRAYERS
ATV SPRAYERS
TRAILER SPRAYERS
UTILITY & 3PT SPRAYERS
SKID SPRAYERS & BOOMS
PUMPS
SPRAYER ACCESSORIES
DRY MATERIAL SPREADERS
TRAILER CARTS & AERATORS
SPRAYER COMPONENTS
PARTSLIST BREAKDOWNS

40 GALLON SPOT SPRAYER

40 Gallon Poly Tank

2.1 GPM Demand Pump With 60 PSI Max Pressure

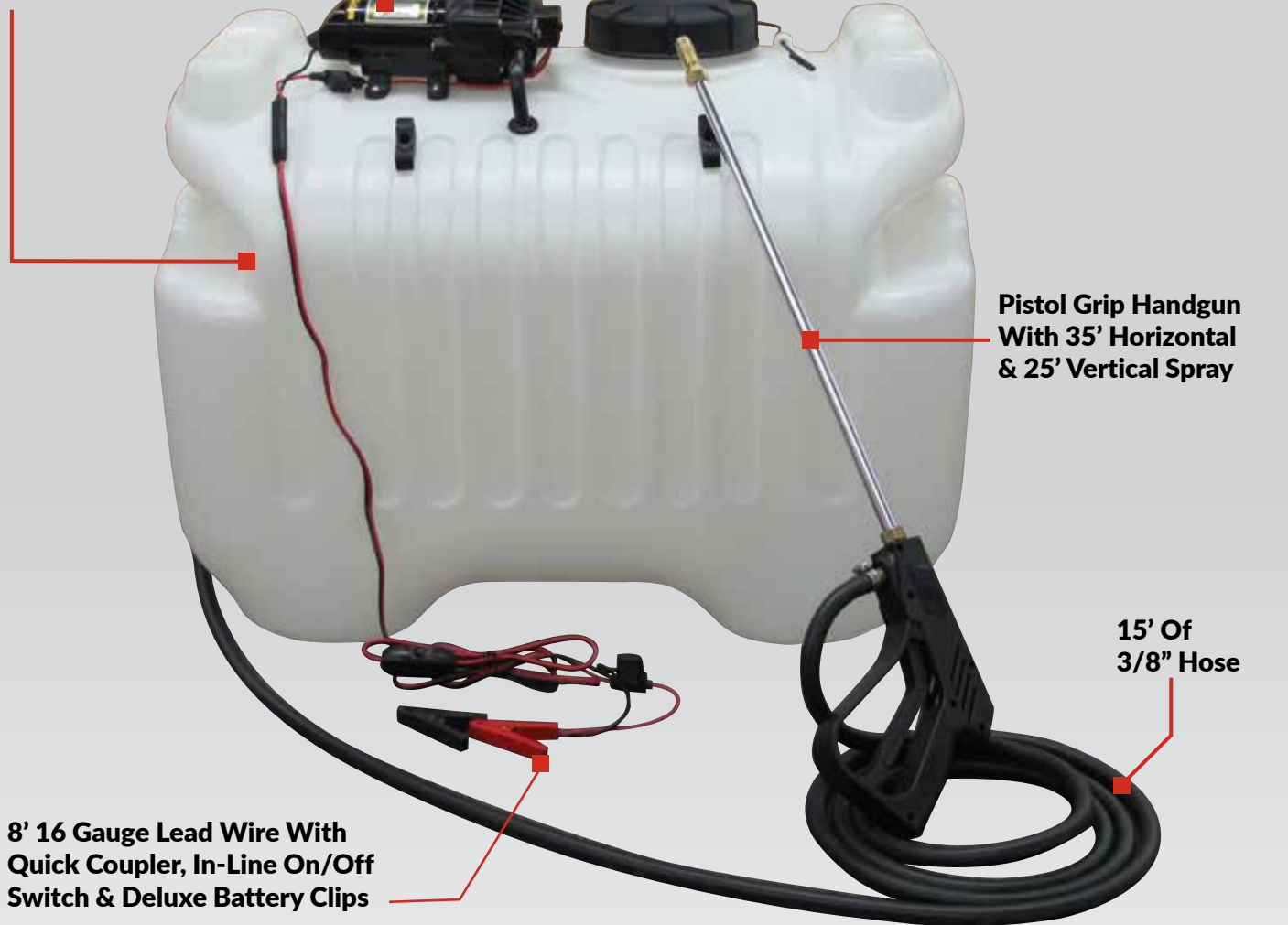

Pistol Grip Handgun With 35' Horizontal & 25' Vertical Spray

15' Of 3/8" Hose

8' 16 Gauge Lead Wire With Quick Coupler, In-Line On/Off Switch & Deluxe Battery Clips

LG-40-DLX

HIGH-FLO PUMP

8' 16 GAUGE LEAD WIRE



Ratchet Straps NOT Included



2.1 GPM

HIGH FLO

- 12 Volt Demand Pump
- 60 PSI Max
- 8 Amp



With Quick Coupler, In-Line On/Off Switch & Deluxe Battery Clips

LG-40-DLX

Sprayer Weight	Water Weight	Sprayer W/Water Weight
28 lbs	334 lbs	362 lbs

Model #	Code #	Tank Size	Shipping Weight	Carton Size	Shipping Class	Cubic Feet	UPS Able	UPC Code	List Price
LG-40-DLX	5302186	40 Gallon	30	30 x 20 x 24	150	8.4	87#	733029107336	\$ 308.00

PRO SERIES SPRAYERS
UTV SPRAYERS
SPOT SPRAYERS
ATV SPRAYERS
TRAILER SPRAYERS
UTILITY & 3PT SPRAYERS
SMID SPRAYERS & BOOMS
PUMPS
SPRAYER ACCESSORIES
DRY MATERIAL SPREADERS
TRAILER CARTS & AERATORS
SPRAYER COMPONENTS
PARTS LIST BREAKDOWNS

40 GALLON SPOT SPRAYERS

40 Gallon Poly Tank

3.8 GPM Demand Pump With 45 PSI Max Pressure

Steel Frame For Complete Drainage

Pistol Grip Handgun With 35' Horizontal & 26' Vertical Spray

8' 16 Gauge Lead Wire With Quick Coupler, In-Line On/Off Switch & Deluxe Battery Clips

25' Of 3/8" Hose

LG-40-SS

HIGH-FLO PUMP

8' 16 GAUGE LEAD WIRE



3.8 GPM **HIGH FLO**

- 12 Volt Demand Pump
- 45 PSI Max
- 11 Amp



With Quick Coupler, In-Line On/Off Switch & Deluxe Battery Clips

LG-40-SS

Sprayer Weight	Water Weight	Sprayer W/Water Weight
52 lbs	334 lbs	386 lbs

Model #	Code #	Tank Size	Shipping Weight	Carton Size	Shipping Class	Cubic Feet	UPS Able	UPC Code	List Price
LG-40-SS	5301335	40 Gallon	55	40 x 26 x 25	150	15.1	NO	733029003096	\$ 498.00

WHEELED SPOT SPRAYER LINEUP



MODEL NUMBER (PART NUMBER - CATALOG PAGE)	LG-4-3-1 (5302314 - PAGE 25)	LG-8-P (5302164 - PAGE 26)	LG-5P (5302165 - PAGE 26)
TANK SIZE			
- 4 Gallons	X		
- 5 Gallons			X
- 8 Gallons		X	
PUMP SIZE (GPM)			
- High-Flo 1.0 GPM		X	X
- Lithium Ion .15 GPM	X		
HANDGUN TYPE			
- Lever Handgun With X-26 Poly Tip		X	X
- Lithium Ion Handgun With Adjustable Poly Tip	X		
HANDGUN SPRAY DISTANCE			
- 15' Horizontal & 8' Vertical	X		
- 25' Horizontal & 12' Vertical		X	X
HANDGUN HOSE LENGTH			
- 15' of 3/8"			X
- 15' of 3/8" Coiled Hose		X	
- 8' of Coiled Hosesd	X		
HANDGUN HOLDER			
- Molded Clips	X	X	
- Hose Wrap On Handle			X
FILLING LID			
- 5" Standard		X	
- 3" Fill Cap	X		
- 2" Fill Cap			X
TIRES			
- 8" Plastic Wheels, White Rims		X	
- 10" Rubber Wheels, White Rims			X
- 8" Plastic Wheels, Gray Rims	X		



SPRAYER TANK NEUTRALIZER & CLEANER

Fimco's Tank Neutralizer cleaning agent is especially designed to clean sprayers. Removes dirt, scale and rust from spray booms and tanks, as well as neutralizing the chemical action of spray chemicals previously used in this equipment. A completely soluble powder.

Recommended to be used for flushing sprayers after each time used. Reduces corrosion in tanks and pumps.

Code #	Description	List Price
5173029	2 lb. Can (Packed 12 per Case)	\$ 36.00

LITHIUM ION WHEELED SPOT SPRAYER

Rechargeable
.15 GPM Lithium
Ion Battery
Powered Handgun
/ Pump With
Continuous Use
For 1 Hour

2.5 Hour
Recharge Time

8' Of Flexible
Coiled Hose
For Ease Of
Use

Lithium Ion
Handgun
With 15'
Horizontal
& 8' Vertical
Spray

4 Gallon
Poly Tank

8" Plastic
Wheels,
Gray Rims

Adjustable
Nozzle
From
Straight
To Mist



WHEELED



HANDHELD



BACKPACK



LG-4-3-1

Sprayer Weight	Water Weight	Sprayer W/Water Weight
20 lbs	33 lbs	53 lbs

Model #	Code #	Tank Size	Shipping Weight	Carton Size	Shipping Class	Cubic Feet	UPS Able	UPC Code	List Price
LG-4-3-1	5302314	4 Gallon	20	14 x 11 x 23	150	2.1	22#	733029109989	\$ 163.00

PRO SERIES SPRAYERS
UTV SPRAYERS
SPOT SPRAYERS
ATV SPRAYERS
TRAILER SPRAYERS
UTILITY & 3PT SPRAYERS
SKID SPRAYERS & BOOMS
PUMPS
SPRAYER ACCESSORIES
DRY MATERIAL SPREADERS
TRAILER CARTS & AERATORS
SPRAYER COMPONENTS
PARTSLIST BREAKDOWNS

WHEELED SPOT SPRAYERS



- 8 Gallon Tank
- Diaphragm Pump
- 1.0 G.P.M.; 35 P.S.I.

- 8 Inch Wheels
- Collapsable Handle
- 15' of Coiled Hose

- 12 Volt Battery rechargeable
- Handgun w/Adjustable Tip
- Battery & Charger Included

Sprayer Weight	Water Weight	Sprayer W/Water Weight
23 lbs	67 lbs	90 lbs

LG-8-P

Model #	Code #	Tank Size	Shipping Weight	Carton Size	Shipping Class	Cubic Feet	UPS Able	UPC Code	List Price
LG-8-P	5302164	8 Gallon	24	19 x 17 x 23	150	4.3	45#	733029007841	\$ 261.00



- 5 Gallon Tank
- 10 Inch Wheels
- Diaphragm Pump
- 1.0 G.P.M.; 35 P.S.I.
- Totally Enclosed Pump & Battery
- 12 Volt Battery rechargeable
- 15' Hand Gun Hose
- 18" Handgun w/Adjustable Tip
- Steel Frame & Handle
- Longer Lasting Battery & Charger Included
- Quick Change Tank Design

Sprayer Weight	Water Weight	Sprayer W/Water Weight
36 lbs	42 lbs	78 lbs

LG-5P

Model #	Code #	Tank Size	Shipping Weight	Carton Size	Shipping Class	Cubic Feet	UPS Able	UPC Code	List Price
LG-5-P	5302165	5 Gallon	33	21 x 18 x 23	150	4.8	52#	733029002211	\$ 410.00

LITHIUM ION POWERED HANDGUN / PUMP



Easily Convert Your Pump Up Style Sprayer For Effortless Spraying



HOSE & SPRAYER NOT INCLUDED

- Lithium Ion Battery Powered Handgun / Pump With Continuous Use Over 1 Hour
- 2.5 Hour Recharge Time
- Roundup® Ready

.15 GPM LITHIUM ION BATTERY POWERED PUMP

SPRAY DISTANCE
15 FT HORIZONTAL
8 FT VERTICAL



LITHIUM ION POWERED HANDGUN

Model #	Code #	UPC Code	List Price
7771966	7771966	733029110626	\$ 86.82

PRO SERIES SPRAYERS
UTV SPRAYERS
SPOT SPRAYERS
ATV SPRAYERS
TRAILER SPRAYERS
UTILITY & 3PT SPRAYERS
SKID SPRAYERS & BOOMS
PUMPS
SPRAYER ACCESSORIES
DRY MATERIAL SPREADERS
TRAILER CARTS & AERATORS
SPRAYER COMPONENTS
PARTSLIST BREAKDOWNS

ATV SPRAYER LINEUP



MODEL NUMBER (PART NUMBER - CATALOG PAGE)	ATV-15-2QR (5302318 - PAGE 31)	ATV-20-2QR (5302319 - PAGE 31)	ATV-25-700-QR (5302320 - PAGE 32)
TANK SIZE			
- 15 Gallons	X		
- 20 Gallons		X	
- 25 Gallons			X
PUMP SIZE (GPM)			
- High-Flo 2.1 GPM	X	X	X
- High-Flo 3.8 GPM			
PRESSURE (PSI)			
- 60 PSI	X	X	X
- 45 PSI			
MANIFOLD			
- Unit Utilizes Manifold System	X	X	X
PRESSURE GAUGE			
- 2" Dry 100 PSI Pressure Gauge	X	X	X
HANDGUN TYPE			
- Lever Handgun With X-26 Poly Tip	X	X	X
- Pistol Grip Handgun With X-26 Brass Tip			
HANDGUN SPRAY DISTANCE			
- 30' Horizontal & 15' Vertical	X	X	X
- 35' Horizontal & 26' Vertical			
HANDGUN HOSE LENGTH			
- 15' of 3/8"	X	X	X
HANDGUN HOLDER			
- Molded Clips	X	X	X
SPRAY TIPS			
- TF-VP3 Wide Angle Tip	X	X	
- AIXR Air Inducted Tip			X
- XTender End Tips			
- XTender End Tips & Center Tip			
NUMBER OF BOOM NOZZLES			
- 2	X	X	
- 3			
- 7			X
BOOM SPRAY COVERAGE			
- 80" Coverage	X	X	
- 140" Coverage			X
- 28' Coverage			
- 30' Coverage			
BOOM TYPE			
- Rigid L-Shape	X	X	
- 3-Section Folding Boom			X
- 3-Section Folding Boom, Deluxe Shielded Boom			
- 2-Bracket			
- Wet Boom			
QUICK RELEASE BOOM			
- Unit Utilizes Quick Release Boom	X	X	X
LEAD WIRE			
- 96" Lead Wire	X	X	X
FILLING LID			
- 5" Standard	X	X	X

ATV SPRAYER LINEUP



MODEL NUMBER (PART NUMBER - CATALOG PAGE)	ATV-25-71-QR (5302321 - PAGE 33)	LG-25-BL-QR (5302323 - PAGE 34)	LG-3025-QR (5302322 - PAGE 35)
TANK SIZE			
- 15 Gallons			
- 20 Gallons			
- 25 Gallons	X	X	X
PUMP SIZE (GPM)			
- High-Flo 2.1 GPM			
- High-Flo 3.8 GPM	X	X	X
PRESSURE (PSI)			
- 60 PSI			
- 45 PSI	X	X	X
MANIFOLD			
- Unit Utilizes Manifold System	X	X	X
PRESSURE GAUGE			
- 2" Dry 100 PSI Pressure Gauge	X	X	X
HANDGUN TYPE			
- Lever Handgun With X-26 Tip			
- Pistol Grip Handgun With X-26 Tip	X	X	X
HANDGUN SPRAY DISTANCE			
- 30' Horizontal & 15' Vertical			
- 35' Horizontal & 26' Vertical	X	X	X
HANDGUN HOSE LENGTH			
- 15' of 3/8"	X	X	X
HANDGUN HOLDER			
- Molded Clips	X	X	X
SPRAY TIPS			
- TF-VP3 Wide Angle Tip			
- AIXR Air Inducted Tip	X		
- XTender End Tips		X	
- XTender End Tips & Center Tip			X
NUMBER OF BOOM NOZZLES			
- 2		X	
- 3			X
- 7	X		
BOOM SPRAY COVERAGE			
- 80" Coverage			
- 140" Coverage	X		
- 28' Coverage		X	
- 30' Coverage			X
BOOM TYPE			
- Rigid L-Shape			
- 3-Section Folding Boom			
- 3-Section Folding Boom, Deluxe Shielded Boom	X		
- 2-Bracket		X	
- Wet Boom			X
QUICK RELEASE BOOM			
- Unit Utilizes Quick Release Boom	X	X	X
LEAD WIRE			
- 96" Lead Wire	X	X	X
FILLING LID			
- 5" Standard	X	X	X

PRO SERIES SPRAYERS
UTV SPRAYERS
SPOT SPRAYERS
ATV SPRAYERS
TRAILER SPRAYERS
UTILITY & 3PT SPRAYERS
SKID SPRAYERS & BOOMS
PUMPS
SPRAYER ACCESSORIES
DRY MATERIAL SPREADERS
TRAILER CARTS & AERATORS
SPRAYER COMPONENTS
PARTSLIST BREAKDOWNS



WHAT OPTIONS ARE AVAILABLE FOR YOUR ATV SPRAYER?



PRO SERIES SPRAYERS
UTV SPRAYERS
SPOT SPRAYERS
ATV SPRAYERS
TRAILER SPRAYERS
UTILITY & 3PT SPRAYERS
SKID SPRAYERS & BOOMS
PUMPS
SPRAYER ACCESSORIES
DRY MATERIAL SPREADERS
TRAILER CARTS & AERATORS
SPRAYER COMPONENTS
PARTS/LIST BREAKDOWNS

ADVANCEMENT IN SPRAY TIPS: ANTI-DRIP STRAINERS

TF-VP3 PREMIUM WIDE ANGLE
INCLUDES NEW ANTI-DRIP STRAINER



AIXR PREMIUM AIR INDUCED
INCLUDES NEW ANTI-DRIP STRAINER



AIXR PREMIUM AIR INDUCED
INCLUDES CHEMSAVER DRIP-FREE SHUT OFF



XTENDER TIPS

INCLUDES NEW ANTI-DRIP STRAINER

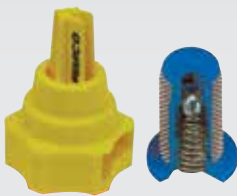

ADVANCEMENT IN BOOMS: QUICK RELEASE (QR) CLAMPS

QUICK RELEASE BOOM CLAMPS ALLOW OPERATOR TO QUICKLY INSTALL / REMOVE SPRAYER BOOMS TO MAXIMIZE PRODUCTIVITY



OPEN
Remove Or Insert Boom



CLOSED
Clamps Boom Into Place

2-NOZZLE ATV SPRAYERS

15 Or 20 Gallon Poly Tank

2.1 GPM High-Flo 12V Pump; 60 PSI; 8 Amp

Innovative Manifold With On/Off Valves For Pressure/Control & Boom Operation With 2" Dry 100 PSI Pressure Gauge

5" Fill Lid

Lever Handgun With 30' Horizontal & 15' Vertical Spray

15' Of 3/8" Hose

2 Nozzle Boom - 80" Spray Coverage

Quick Release Feature Allows Operator To Quickly Install / Remove Spray Boom To Convert From Spot To ATV Sprayer



ATV-15-2QR



INNOVATIVE MANIFOLD

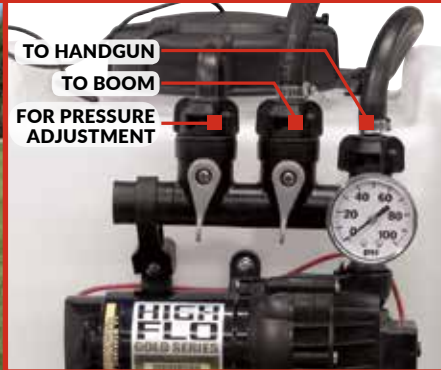

SPRAY TIPS & BOOM PATTERN

TF-VP3 PREMIUM WIDE ANGLE
INCLUDES NEW ANTI-DRIP STRAINER



2-NOZZLE BOOM SPRAY PATTERN (80")



ATV-15-2QR & ATV-20-2QR

Sprayer Model	Sprayer Weight	Water Weight	Sprayer W/Water Weight
ATV-15-2QR	25 lbs	125 lbs	150 lbs
ATV-20-2QR	27 lbs	167 lbs	194 lbs

See Page 159 For Exploded View & Parts List

Model #	Code #	Tank Size	Shipping Weight	Carton Size	Shipping Class	Cubic Feet	UPS Able	UPC Code	List Price
ATV-15-2QR	5302318	15 Gallon	29	40 x 19 x 16	150	7.1	74#	733029110022	\$ 375.00
ATV-20-2QR	5302319	20 Gallon	30	40 x 19 x 16	150	7.1	74#	733029110039	\$ 392.00

PRO SERIES SPRAYERS
UTV SPRAYERS
SPOT SPRAYERS
ATV SPRAYERS
TRAILER SPRAYERS
UTILITY & 3PT SPRAYERS
SKID SPRAYERS & BOOMS
PUMPS
SPRAYER ACCESSORIES
DRY MATERIAL SPREADERS
TRAILER CARTS & AERATORS
SPRAYER COMPONENTS
PARTSLIST BREAKDOWNS

7-NOZZLE ATV SPRAYER

25 Gallon Poly Tank

2.1 GPM High-Flo 12V Pump; 60 PSI; 8 Amp

Innovative Manifold With On/Off Valves For Pressure/Control & Boom Operation With 2" Dry 100 PSI Pressure Gauge

5" Fill Lid

Lever Handgun With 30' Horizontal & 15' Vertical Spray

15' Of 3/8" Hose

7 Nozzle, 3 Section Folding Boom - 140" Spray Coverage

Quick Release Feature Allows Operator To Quickly Install / Remove Spray Boom To Convert From Spot To ATV Sprayer

ATV-25-700-QR

INNOVATIVE MANIFOLD

SPRAY TIPS & BOOM PATTERN

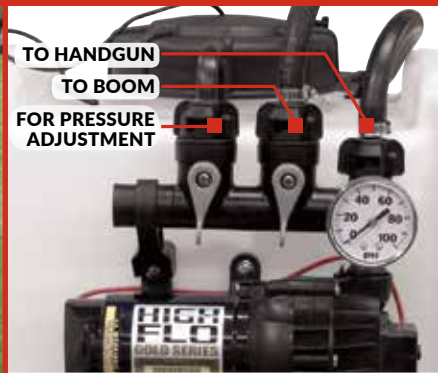

ATV-25-700-QR

Sprayer Weight	Water Weight	Sprayer W/Water Weight
59 lbs	209 lbs	268 lbs

Model #	Code #	Tank Size	Shipping Weight	Carton Size	Shipping Class	Cubic Feet	UPS Able	UPC Code	List Price
ATV-25-700-QR	5302320	25 Gallon	63	56 x 20 x 21	150	13.7	142#	733029110046	\$ 526.00

7-NOZZLE DELUXE ATV SPRAYER



25 Gallon Poly Tank

3.8 GPM High-Flo 12V Pump; 45 PSI; 11 Amp

Innovative Manifold With On/Off Valves For Pressure/Control & Boom Operation With 2" Dry 100 PSI Pressure Gauge

5" Fill Lid

Pistol Grip Handgun With 35' Horizontal & 26' Vertical Spray

15' Of 3/8" Hose

7 Nozzle, 3 Section Folding Deluxe Boom (Shielded Tips) - 140" Spray Coverage

Quick Release Feature Allows Operator To Quickly Install / Remove Spray Boom To Convert From Spot To ATV Sprayer

ATV-25-71-QR



Ratchet Straps NOT Included

INNOVATIVE MANIFOLD

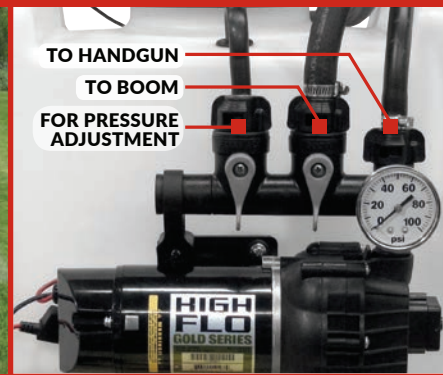

SPRAY TIPS & BOOM PATTERN



Sprayer Weight	Water Weight	Sprayer W/Water Weight
64 lbs	209 lbs	273 lbs

ATV-25-71-QR

See Page 160 For Exploded View & Parts List

Model #	Code #	Tank Size	Shipping Weight	Carton Size	Shipping Class	Cubic Feet	UPS Able	UPC Code	List Price
ATV-25-71-QR	5302321	25 Gallon	68	56 x 20 x 21	150	13.7	142#	733029110053	\$ 694.00

PRO SERIES SPRAYERS
UTV SPRAYERS
SPOT SPRAYERS
ATV SPRAYERS
TRAILER SPRAYERS
UTILITY & 3PT SPRAYERS
SKID SPRAYERS & BOOMS
PUMPS
SPRAYER ACCESSORIES
DRY MATERIAL SPREADERS
TRAILER CARTS & AERATORS
SPRAYER COMPONENTS
PARTSLIST BREAKDOWNS

2-NOZZLE BOOMLESS ATV SPRAYER

PRO SERIES SPRAYERS
UTV SPRAYERS
SPOT SPRAYERS
ATV SPRAYERS
TRAILER SPRAYERS
UTILITY & 3PT SPRAYERS
SKID SPRAYERS & BOOMS
PUMPS
SPRAYER ACCESSORIES
DRY MATERIAL SPREADERS
TRAILER CARTS & AERATORS
SPRAYER COMPONENTS
PARTS LIST BREAKDOWNS



LG-25-BL-QR

Ratchet Straps NOT Included

INNOVATIVE MANIFOLD

TO HANDGUN
TO BOOM
FOR PRESSURE ADJUSTMENT

SPRAY TIPS & BOOM PATTERN

XTENDER TIPS

INCLUDES NEW ANTI-DRIP STRAINER

BOOMLESS NOZZLE SPRAY PATTERN (28')

LG-25-BL-QR

Sprayer Weight	Water Weight	Sprayer W/Water Weight
31 lbs	209 lbs	240 lbs

Model #	Code #	Tank Size	Shipping Weight	Carton Size	Shipping Class	Cubic Feet	UPS Able	UPC Code	List Price
LG-25-BL-QR	5302323	25 Gallon	35	39 x 19 x 16	150	6	62#	733029110077	\$ 595.00

3-NOZZLE BOOMLESS ATV SPRAYER



LG-3025-QR



INNOVATIVE MANIFOLD

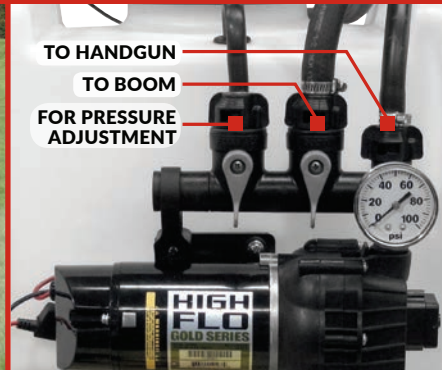

SPRAY TIPS & BOOM PATTERN

XTENDER TIPS & CENTER TIP

INCLUDES DRIP FREE SHUT OFF VALVES



BOOMLESS NOZZLE SPRAY PATTERN (30')

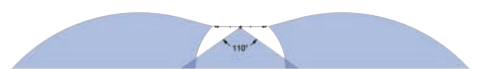

Sprayer Weight	Water Weight	Sprayer W/Water Weight
31 lbs	209 lbs	240 lbs

LG-3025-QR

See Page 161 For Exploded View & Parts List

Model #	Code #	Tank Size	Shipping Weight	Carton Size	Shipping Class	Cubic Feet	UPS Able	UPC Code	List Price
LG-3025-QR	5302322	25 Gallon	35	39 x 19 x 16	150	6	62#	733029110060	\$ 657.00

TRAILER SPRAYER LINEUP



MODEL NUMBER (PART NUMBER - CATALOG PAGE)	LG-* -TRL (PAGES 39 & 40)	LG-*500-303 (PAGE 41)	TR-* -EX (PAGE 41)	LG-2500-BL (5302182 - PAGE 42)
TANK SIZE				
- 15 Gallons		X		
- 20 Gallons	X		X	
- 25 Gallons		X		X
- 30 Gallons	X		X	
- 40 Gallons				
- 60 Gallons				
PUMP SIZE (GPM)				
- High-Flo 2.1 GPM	X	X	X	
- High-Flo 3.8 GPM				X
GAS ENGINE				
- 3.5 HP Gas Engine With 4 Roller Pump				
PRESSURE (PSI)				
- 45 PSI				X
- 60 PSI	X	X	X	
- 120 PSI				
MANIFOLD				
- Unit Utilizes Manifold System	X	X	X	X
PRESSURE GAUGE				
- 2" Dry 100 PSI Pressure Gauge	X	X	X	X
- 200 PSI Pressure Gauge				
HANDGUN TYPE				
- Lever Handgun With X-26 Poly Tip		X	X	
- Pistol Grip Handgun With X-26 Brass Tip	X			X
HANDGUN SPRAY DISTANCE				
- 30' Horizontal & 15' Vertical		X	X	
- 35' Horizontal & 25' Vertical	X			
- 35' Horizontal & 26' Vertical				X
- 45' Horizontal & 30' Vertical				
HANDGUN HOSE LENGTH				
- 15' of 3/8"	X	X	X	X
- 25' of 3/8"				
HANDGUN HOLDER				
- Molded Clips		X	X	X
- Front Mounted Hose Wrap	X			
- Side Mounted Hose Wrap				
SPRAY TIPS				
- TF-VP3 Wide Angle Tip	X	X	X	
- AIXR Air Inducted Tip				
- XTender End Tips				X
- XTender End Tips & Center Tip				
NUMBER OF BOOM NOZZLES				
- 2	X	X	X	X
- 3				
- 5				
- 7				
BOOM SPRAY COVERAGE				
- 80" Coverage	X	X	X	
- 100" Coverage				
- 140" Coverage				
- 28' Coverage				X
- 30' Coverage				
BOOM TYPE				
- Rigid L-Shape		X	X	
- Breakaway 2-Nozzle Boom	X			
- 3-Section Folding Boom				
- 2-Bracket				X
- Wet Boom				
LEAD WIRE				
- 96" Lead Wire	X	X	X	X
FILLING LID				
- 5" Standard	X	X	X	X

TRAILER SPRAYER LINEUP



MODEL NUMBER (PART NUMBER - CATALOG PAGE)	TR-40-EX (5301338 - PAGE 43)	TR-40-GAS (5301339 - PAGE 44)	ATVTS-60-12V (PAGE 45)	ATVTS-60-4R (PAGE 46)
TANK SIZE				
- 15 Gallons				
- 20 Gallons				
- 25 Gallons				
- 30 Gallons				
- 40 Gallons	X	X		
- 60 Gallons			X	X
PUMP SIZE (GPM)				
- High-Flo 2.1 GPM	X			
- High-Flo 3.8 GPM			X	
GAS ENGINE				
- 3.5 HP Gas Engine With 4 Roller Pump		X		X
PRESSURE (PSI)				
- 45 PSI			X	
- 60 PSI	X			
- 120 PSI		X		X
MANIFOLD				
- Unit Utilizes Manifold System	X		X	
PRESSURE GAUGE				
- 2" Dry 100 PSI Pressure Gauge	X		X	X
- 200 PSI Pressure Gauge		X		
HANDGUN TYPE				
- Lever Handgun With X-26 Tip				
- Pistol Grip Handgun With X-26 Tip	X	X	X	X
HANDGUN SPRAY DISTANCE				
- 30' Horizontal & 15' Vertical				
- 35' Horizontal & 25' Vertical	X			
- 35' Horizontal & 26' Vertical			X	
- 45' Horizontal & 30' Vertical		X		X
HANDGUN HOSE LENGTH				
- 15' of 3/8"				
- 25' of 3/8"	X	X	X	X
HANDGUN HOLDER				
- Molded Clips				
- Front Mounted Hose Wrap				
- Side Mounted Hose Wrap	X	X	X	X
SPRAY TIPS				
- TF-VP3 Wide Angle Tip				
- AIXR Air Inducted Tip	X	X	X	X
- XTender End Tips				
- XTender End Tips & Center Tip			X	X
NUMBER OF BOOM NOZZLES				
- 2				
- 3			X	X
- 5	X	X		
- 7			X	X
BOOM SPRAY COVERAGE				
- 80" Coverage				
- 100" Coverage	X	X		
- 140" Coverage			X	X
- 28' Coverage				
- 30' Coverage			X	X
BOOM TYPE				
- Rigid L-Shape				
- Breakaway 2-Nozzle Boom				
- 3-Section Folding Boom	X	X	X	X
- 2-Bracket				
- Wet Boom			X	X
LEAD WIRE				
- 96" Lead Wire	X		X	
FILLING LID				
- 5" Standard	X	X	X	X

PRO SERIES SPRAYERS
UTV SPRAYERS
SPOT SPRAYERS
ATV SPRAYERS
TRAILER SPRAYERS
UTILITY & 3PT SPRAYERS
SKID SPRAYERS & BOOMS
PUMPS
SPRAYER ACCESSORIES
DRY MATERIAL SPREADERS
TRAILER CARTS & AERATORS
SPRAYER COMPONENTS
PARTSLIST BREAKDOWNS



WHAT OPTIONS ARE AVAILABLE FOR YOUR TRAILER SPRAYER?

PRO SERIES SPRAYERS
UTV SPRAYERS
SPOT SPRAYERS
ATV SPRAYERS
TRAILER SPRAYERS
UTILITY & 3PT SPRAYERS
SKID SPRAYERS & BOOMS
PUMPS
SPRAYER ACCESSORIES
DRY MATERIAL SPREADERS
TRAILER CARTS & AERATORS
SPRAYER COMPONENTS
PARTS LIST BREAKDOWNS



ADVANCEMENT IN SPRAY TIPS: ANTI-DRIP STRAINERS

TF-VP3 PREMIUM WIDE ANGLE
INCLUDES NEW ANTI-DRIP STRAINER



AIXR PREMIUM AIR INDUCED
INCLUDES NEW ANTI-DRIP STRAINER



XTENDER TIPS
INCLUDES NEW ANTI-DRIP STRAINER

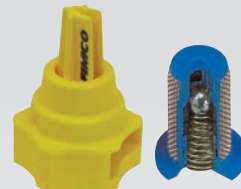

BREAKAWAY SPRING SYSTEM



NEW BREAKAWAY SPRING SYSTEM ALLOWS THE BOOM TO BE FOLDED BACKWARDS OR FORWARDS.

GREAT FOR STORING IN COMPACT SPACES.

INNOVATIVE MANIFOLD

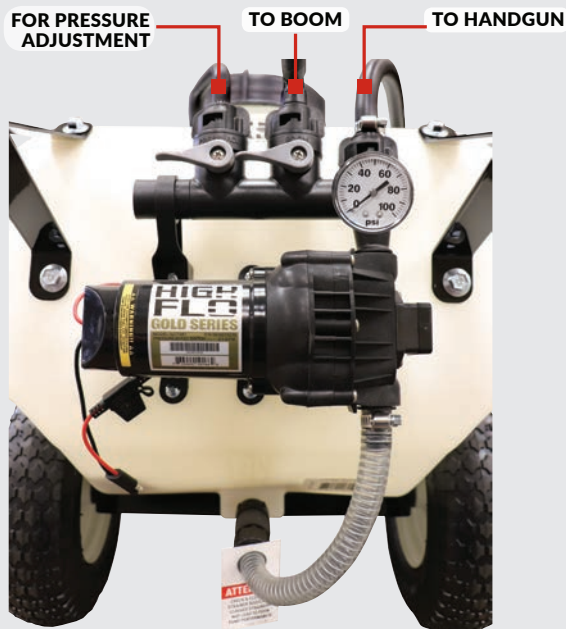

20 GALLON TRAILER SPRAYER



20 Gallon Poly Tank

5" Fill Lid

Pistol Grip Handgun With 35' Horizontal & 25' Vertical Spray

15' Of 3/8" Hose

2 Nozzle Breakaway Boom Design - 80" Spray Coverage

Innovative Manifold With On/Off Valves For Pressure/Control & Boom Operation

2.1 GPM Demand Pump With 60 PSI Max Pressure

2" Dry 100 PSI Pressure Gauge

4.10/3.50 - 6 Tire 5/8" Axle

Square Steel Frame

8' 16 Gauge Lead Wire With Quick Coupler, In-Line On/Off Switch & Deluxe Battery Clips **PLUS 5' Extension Wire**

Adjustable Height Hitch

LG-20-TRL

INNOVATIVE MANIFOLD

SPRAY TIPS & BOOM PATTERN

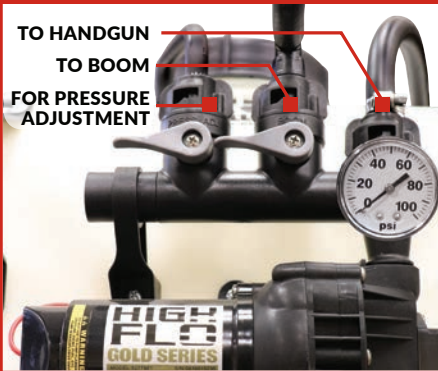

TF-VP3 PREMIUM WIDE ANGLE
INCLUDES NEW ANTI-DRIP STRAINER



2-NOZZLE BOOM SPRAY PATTERN (80")



Sprayer Weight	Water Weight	Sprayer W/Water Weight
51 lbs	167 lbs	218 lbs

LG-20-TRL

See Page 163 For Exploded View & Parts List

Model #	Code #	Tank Size	Shipping Weight	Carton Size	Shipping Class	Cubic Feet	UPS Able	UPC Code	List Price
LG-20-TRL	5302316	20 Gallon	54	36 x 20 x 17	150	7.1	74#	733029110008	\$ 513.00

30 GALLON TRAILER SPRAYER

30 Gallon Poly Tank

5" Fill Lid

Pistol Grip Handgun With 35' Horizontal & 25' Vertical Spray

15' Of 3/8" Hose

2 Nozzle Breakaway Boom Design - 80" Spray Coverage

Adjustable Height Hitch

Innovative Manifold With On/Off Valves For Pressure/Control & Boom Operation

2.1 GPM Demand Pump With 60 PSI Max Pressure

4.80/4.00 - 8 Tire 3/4" Axle

Square Steel Frame

2" Dry 100 PSI Pressure Gauge

8' 16 Gauge Lead Wire With Quick Coupler, In-Line On/Off Switch & Deluxe Battery Clips **PLUS 5' Extension Wire**

LG-30-TRL

INNOVATIVE MANIFOLD

SPRAY TIPS & BOOM PATTERN

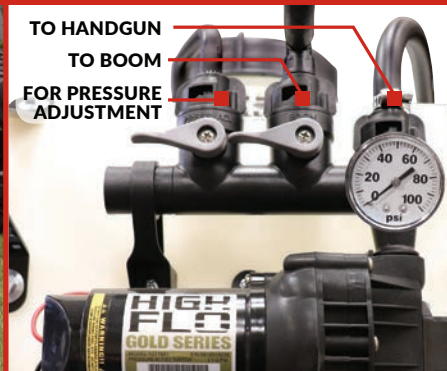

Sprayer Weight	Water Weight	Sprayer W/Water Weight
63 lbs	250 lbs	313 lbs

LG-30-TRL

See Page 163 For Exploded View & Parts List

Model #	Code #	Tank Size	Shipping Weight	Carton Size	Shipping Class	Cubic Feet	UPS Able	UPC Code	List Price
LG-30-TRL	5302317	30 Gallon	65	45 x 20 x 20	150	11	109#	733029110015	\$ 564.00

STANDARD TRAILER SPRAYERS

15, 20, 25 Or 30 Gallon Poly Tank

5" Fill Lid

Innovative Manifold With On/Off Valves For Pressure/Control & Boom Operation

2" Dry 100 PSI Pressure Gauge

2.1 GPM High-Flo 12V Pump; 60 PSI; 8 Amp

2 Nozzle Boom - 80" Spray Coverage

4.10/3.50 - 4 Tire 5/8" Axle
(LG-1500-303/TR-20-EX)

4.10/3.50 - 6 Tire 5/8" Axle
(LG-2500-303/TR-30-EX)

8' 16 Gauge Lead Wire With Quick Coupler, In-Line On/Off Switch & Deluxe Battery Clips

Lever Handgun With 30' Horizontal & 15' Vertical Spray

15' Of 3/8" Hose

LG-1500-303



INNOVATIVE MANIFOLD

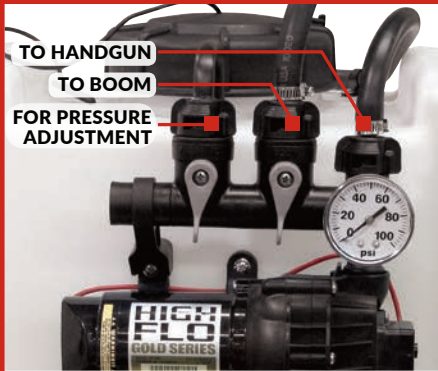

SPRAY TIPS & BOOM PATTERN

TF-VP3 PREMIUM WIDE ANGLE
INCLUDES NEW ANTI-DRIP STRAINER



2-NOZZLE BOOM SPRAY PATTERN (80")



Sprayer Model	Sprayer Weight	Water Weight	Sprayer W/Water Weight
LG-1500-303	46 lbs	125 lbs	171 lbs
LG-2500-303	56 lbs	209 lbs	265 lbs
TR-20-EX	50 lbs	167 lbs	217 lbs
TR-30-EX	62 lbs	250 lbs	312 lbs

LG-1500-303, LG-2500-303, TR-20-EX & TR-30-EX

See Page 162 For Exploded View & Parts List

Model #	Code #	Tank Size	Shipping Weight	Carton Size	Shipping Class	Cubic Feet	UPS Able	UPC Code	List Price
LG-1500-303	5301064	15 Gallon	49	48 x 20 x 17	150	9.5	99#	733029002266	\$ 472.00
LG-2500-303	5301065	25 Gallon	59	50 x 20 x 18	150	10.5	109#	733029002273	\$ 520.00
TR-20-EX	5301549	20 Gallon	51	50 x 20 x 18	150	10.5	109#	733029005274	\$ 496.00
TR-30-EX	5301486	30 Gallon	64	49 x 20 x 19	150	11	115#	733029004703	\$ 543.00

BOOMLESS TRAILER SPRAYERS

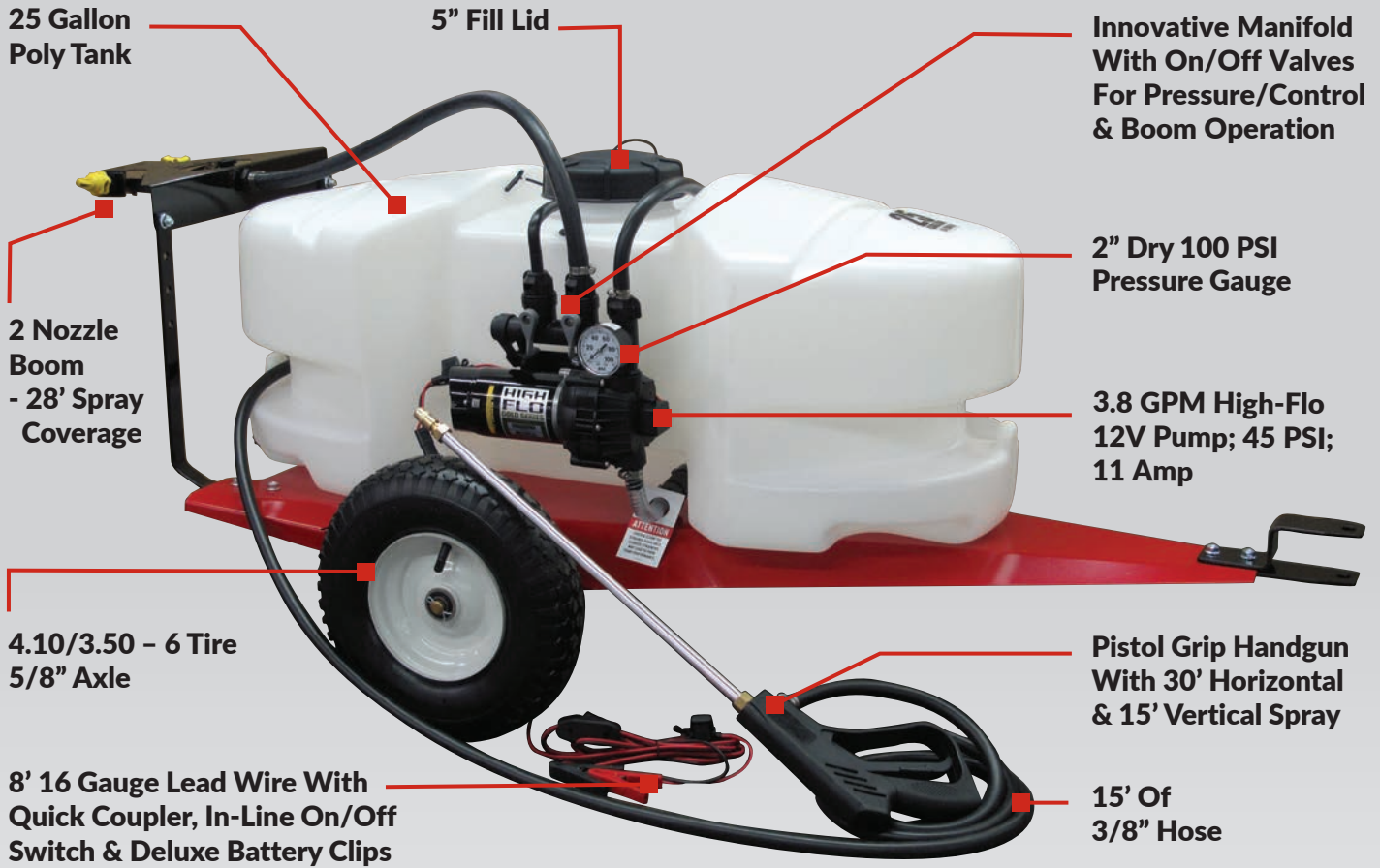

25 Gallon Poly Tank

5" Fill Lid

Innovative Manifold With On/Off Valves For Pressure/Control & Boom Operation

2" Dry 100 PSI Pressure Gauge

2 Nozzle Boom - 28' Spray Coverage

3.8 GPM High-Flo 12V Pump; 45 PSI; 11 Amp

4.10/3.50 - 6 Tire 5/8" Axle

Pistol Grip Handgun With 30' Horizontal & 15' Vertical Spray

8' 16 Gauge Lead Wire With Quick Coupler, In-Line On/Off Switch & Deluxe Battery Clips

15' Of 3/8" Hose

LG-2500-BL



INNOVATIVE MANIFOLD

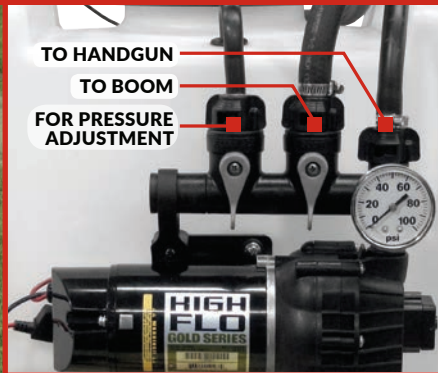

SPRAY TIPS & BOOM PATTERN

XTENDER TIPS

INCLUDES NEW ANTI-DRIP STRAINER

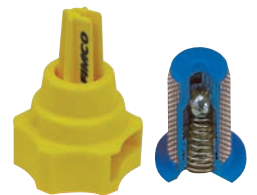

BOOMLESS NOZZLE SPRAY PATTERN (28')



LG-2500-BL

Sprayer Weight	Water Weight	Sprayer W/Water Weight
55 lbs	209 lbs	264 lbs

Model #	Code #	Tank Size	Shipping Weight	Carton Size	Shipping Class	Cubic Feet	UPS Able	UPC Code	List Price
LG-2500-BL	5302182	25 Gallon	59	50 x 20 x 18	150	10.5	109#	733029107350	\$ 587.00

PRO SERIES SPRAYERS
UTV SPRAYERS
SPOT SPRAYERS
ATV SPRAYERS
TRAILER SPRAYERS
UTILITY & 3PT SPRAYERS
SKID SPRAYERS & BOOMS
PUMPS
SPRAYER ACCESSORIES
DRY MATERIAL SPREADERS
TRAILER CARTS & AERATORS
SPRAYER COMPONENTS
PARTS/LIST BREAKDOWNS

40 GALLON TRAILER SPRAYERS



TR-40-EX

INNOVATIVE MANIFOLD

SPRAY TIPS & BOOM PATTERN

AIXR PREMIUM AIR INDUCED
INCLUDES NEW ANTI-DRIP STRAINER

5-NOZZLE BOOM SPRAY PATTERN (100")

Sprayer Weight	Water Weight	Sprayer W/Water Weight
151 lbs	334 lbs	485 lbs

TR-40-EX

See Page 164 For Exploded View & Parts List

Model #	Code #	Tank Size	Shipping Weight	Carton Size	Shipping Class	Cubic Feet	UPS Able	UPC Code	List Price
TR-40-EX	5301338	40 Gallon	205	65 x 26 x 31	150	30.4	NO	733029003126	\$ 1,192.00

PRO SERIES SPRAYERS
 ATV SPRAYERS
 SPOT SPRAYERS
 ATV SPRAYERS
TRAILER SPRAYERS
 UTILITY & 3PT SPRAYERS
 SKID SPRAYERS & BOOMS
 PUMPS
 SPRAYER ACCESSORIES
 DRY MATERIAL SPREADERS
 TRAILER CARTS & AERATORS
 SPRAYER COMPONENTS
 PARTSLIST BREAKDOWNS

40 GALLON TRAILER SPRAYERS



TR-40-GAS

127cc BRIGGS & STRATTON ENGINE

SPRAY TIPS & BOOM PATTERN

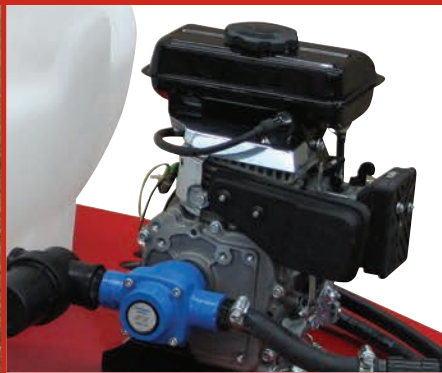

AIXR
PREMIUM
AIR INDUCED
INCLUDES NEW
ANTI-DRIP
STRAINER



5-NOZZLE BOOM SPRAY PATTERN (100")

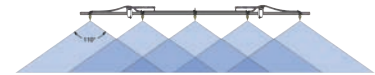

TR-40-GAS

Sprayer Weight	Water Weight	Sprayer W/Water Weight
176 lbs	334 lbs	510 lbs

Model #	Code #	Tank Size	Shipping Weight	Carton Size	Shipping Class	Cubic Feet	UPS Able	UPC Code	List Price
TR-40-GAS	5301339	40 Gallon	230	65 x 26 x 31	150	30.4	NO	733029003133	\$ 1,736.00

60 GALLON TRAILER SPRAYERS



ATVTS-60-12V-BL

SPRAY TIP OPTIONS & BOOM PATTERNS



XTENDER TIPS & CENTER TIP

INCLUDES DRIP FREE SHUT OFF VALVES



BOOMLESS NOZZLE SPRAY PATTERN (30')

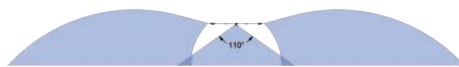

AIXR PREMIUM AIR INDUCED

INCLUDES NEW ANTI-DRIP STRAINER



7-NOZZLE BOOM SPRAY PATTERN (140')



ATVTS-60-12V & ATVTS-60-12V-BL

Sprayer Model	Sprayer Weight	Water Weight	Sprayer W/Water Weight
ATVTS-60-12V	239 lbs	500 lbs	739 lbs
ATVTS-60-12V-BL	239 lbs	500 lbs	739 lbs

See Page 165 For Exploded View & Parts List

Model #	Code #	Tank Size	Shipping Weight	Carton Size	Shipping Class	Cubic Feet	UPS Able	UPC Code	List Price
ATVTS-60-12V	5301192	60 Gallon	295	73.5 x 35 x 30	150	45	NO	733029002686	\$ 1,620.00
ATVTS-60-12V-BL	5301305	60 Gallon	269	73.5 x 35 x 30	150	45	NO	733029003249	\$ 1,683.00

60 GALLON TRAILER SPRAYERS

PRO SERIES
SPRAYERS
UTV
SPRAYERS
SPOT
SPRAYERS
ATV
SPRAYERS
TRAILER
SPRAYERS
UTILITY &
3PT SPRAYERS
SKID SPRAYERS
& BOOMS
PUMPS
SPRAYER
ACCESSORIES
DRY MATERIAL
SPREADERS
TRAILER CARTS
& AERATORS
SPRAYER
COMPONENTS
PARTS/LIST
BREAKDOWNS



ATVTS-60-4R

SPRAY TIP OPTIONS & BOOM PATTERNS



XTENDER TIPS & CENTER TIP

INCLUDES DRIP FREE SHUT OFF VALVES



BOOMLESS NOZZLE SPRAY PATTERN (30')

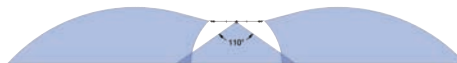

AIXR PREMIUM AIR INDUCED
INCLUDES NEW ANTI-DRIP STRAINER



7-NOZZLE BOOM SPRAY PATTERN (140")



ATVTS-60-4R

Sprayer Model	Sprayer Weight	Water Weight	Sprayer W/Water Weight
ATVTS-60-4R	239 lbs	500 lbs	739 lbs
ATVTS-60-4R-BL	224 lbs	500 lbs	724 lbs

Model #	Code #	Tank Size	Shipping Weight	Carton Size	Shipping Class	Cubic Feet	UPS Able	UPC Code	List Price
ATVTS-60-4R	5301306	60 Gallon	305	73.5 x 35 x 30	150	45.0	NO	733029003256	\$ 2,247.00
ATVTS-60-4R-BL	5301307	60 Gallon	280	73.5 x 35 x 30	150	45.0	NO	733029003232	\$ 2,195.00

PASTURE BLASTER®



PB-300ELTS-BL

Sprayer Weight	Water Weight	Sprayer W/Water Weight
800 lbs	2502 lbs	3302 lbs

Model #	Code #	Tank Size	Shipping Weight	Carton Size	Shipping Class	Cubic Feet	UPS Able	UPC Code	List Price
PB-300ELTS-BL	5301657	300 Gallon	775	121 x 73 x 67	500	343	NO	733029008299	\$ 5,838.00

PRO SERIES SPRAYERS
UTV SPRAYERS
SPOT SPRAYERS
ATV SPRAYERS
TRAILER SPRAYERS
UTILITY & 3PT SPRAYERS
SKID SPRAYERS & BOOMS
PUMPS
SPRAYER ACCESSORIES
DRY MATERIAL SPREADERS
TRAILER CARTS & AERATORS
SPRAYER COMPONENTS
PARTSLIST BREAKDOWNS

3 POINT SPRAYER LINEUP



	MODEL NUMBER (PART NUMBER - CATALOG PAGE)	LG-40-3PT-12V (5302032 - PAGE 49)	LG-40-3PT-12V-BL (5302335 - PAGE 50)	LG-55-3PT (5300576 - PAGE 51)	LG-60-3PT (5301160 - PAGE 52)
TANK SIZE					
- 40 Gallons		X	X		
- 55 Gallons				X	
- 60 Gallons					X
PUMP SIZE (GPM)					
- High-Flo 2.1 GPM		X			
- High-Flo 3.8 GPM			X		
- Roller Pump Not Included				X	X
PRESSURE (PSI)					
- 45 PSI			X		
- 60 PSI		X			
- 300 PSI				X	X
MANIFOLD					
- Unit Utilizes Manifold System		X	X		
PRESSURE GAUGE					
- 2" Dry 100 PSI Pressure Gauge		X	X		
- 2" Dry 400 PSI Pressure Gauge				X	X
HANDGUN TYPE					
- Pistol Grip Handgun With X-26 Tip		X	X		
HANDGUN SPRAY DISTANCE					
- 35' Horizontal & 25' Vertical		X			
- 35' Horizontal & 26' Vertical			X		
HANDGUN HOSE LENGTH					
- 25' of 3/8"		X	X		
HANDGUN HOLDER					
- Molded Clips		X	X		
SPRAY TIPS					
- AIRX Air Inducted Tip		X		X	X
- XTender End Tips & Center Tip			X		
NUMBER OF BOOM NOZZLES					
- 3			X		
- 4		X			
- 7				X	X
BOOM SPRAY COVERAGE					
- 120" Coverage		X			
- 140" Coverage				X	X
- 30' Coverage			X		
BOOM TYPE					
- 3-Section Folding Boom		X		X	X
- Wet Boom			X		
3 POINT HITCH TYPE					
- Category 1		X	X	X	X
LEAD WIRE					
- 96" Lead Wire		X	X		
FILLING LID					
- 5" Standard		X	X	X	X

40 GALLON 3 POINT SPRAYER

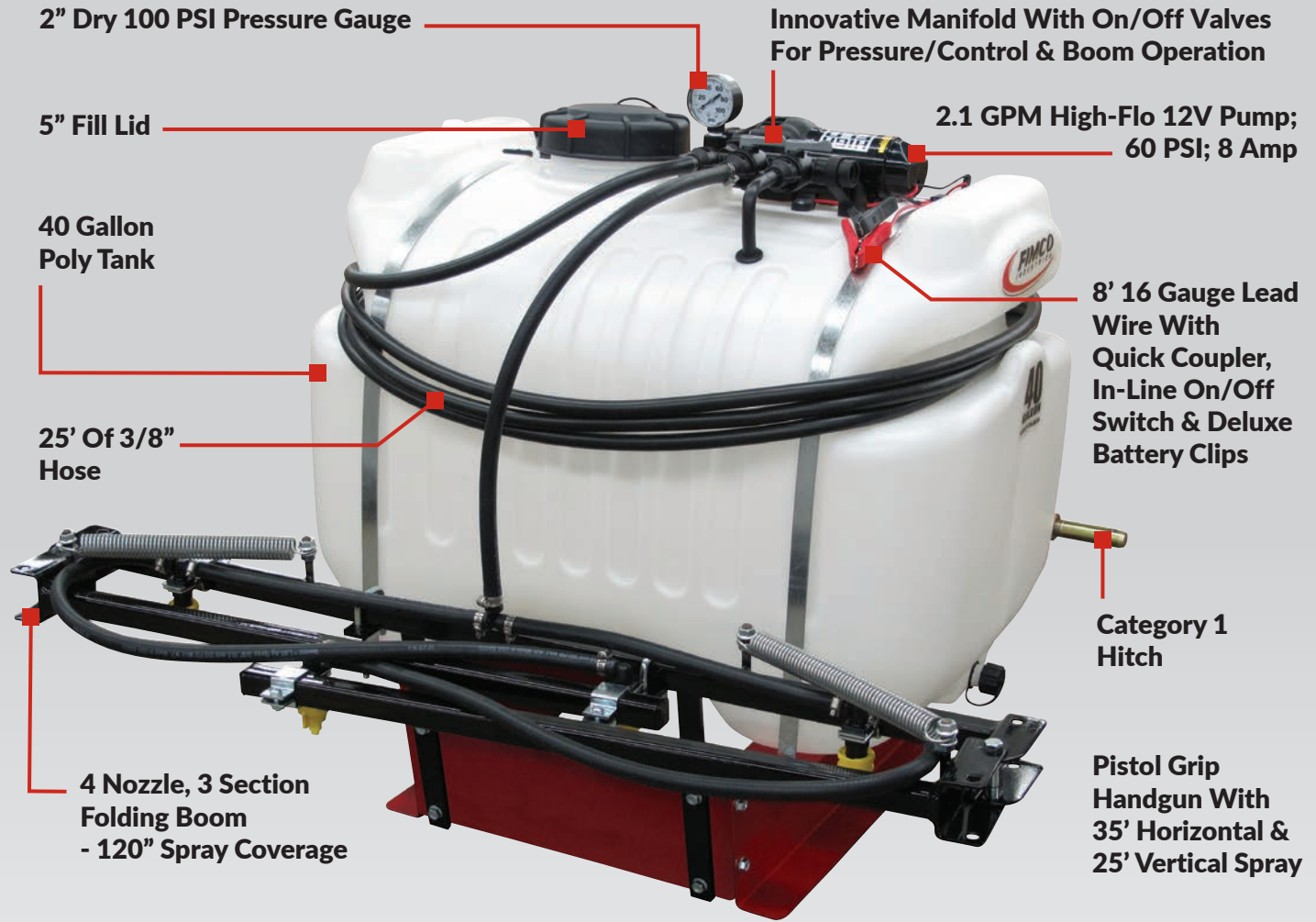

2" Dry 100 PSI Pressure Gauge

Innovative Manifold With On/Off Valves For Pressure/Control & Boom Operation

5" Fill Lid

2.1 GPM High-Flo 12V Pump; 60 PSI; 8 Amp

40 Gallon Poly Tank

8' 16 Gauge Lead Wire With Quick Coupler, In-Line On/Off Switch & Deluxe Battery Clips

25' Of 3/8" Hose

Category 1 Hitch

4 Nozzle, 3 Section Folding Boom - 120" Spray Coverage

Pistol Grip Handgun With 35' Horizontal & 25' Vertical Spray

LG-40-3PT-12V



INNOVATIVE MANIFOLD



SPRAY TIPS & BOOM PATTERN

AIXR
PREMIUM
AIR INDUCED
INCLUDES NEW
ANTI-DRIP
STRAINER



4-NOZZLE BOOM SPRAY PATTERN (120")



Sprayer Weight	Water Weight	Sprayer W/Water Weight
87 lbs	334 lbs	421 lbs

LG-40-3PT-12V

See Page 166 For Exploded View & Parts List

Model #	Code #	Tank Size	Shipping Weight	Carton Size	Shipping Class	Cubic Feet	UPS Able	UPC Code	List Price
LG-40-3PT-12V	5302032	40 Gallon	90	40 x 24 x 24	150	13.4	139#	733029010513	\$ 723.00

PRO SERIES SPRAYERS
UTV SPRAYERS
SPOT SPRAYERS
ATV SPRAYERS
TRAILER SPRAYERS
UTILITY & 3PT SPRAYERS
SKID SPRAYERS & BOOMS
PUMPS
SPRAYER ACCESSORIES
DRY MATERIAL SPREADERS
TRAILER CARTS & AERATORS
SPRAYER COMPONENTS
PARTS LIST BREAKDOWNS

40 GALLON BOOMLESS 3 POINT SPRAYER

2" Dry 100 PSI Pressure Gauge

Innovative Manifold With On/Off Valves For Pressure/Control & Boom Operation

5" Fill Lid

3.8 GPM High-Flo 12V Pump; 45 PSI; 11 Amp

40 Gallon Poly Tank

8' 16 Gauge Lead Wire With Quick Coupler, In-Line On/Off Switch & Deluxe Battery Clips

25' Of 3/8" Hose

Category 1 Hitch

All 3 Nozzles Have Built-In Drip Free Shutoff Valves To Spray From 6' To 30'

Pistol Grip Handgun With 35' Horizontal & 26' Vertical Spray

LG-40-3PT-12V-BL

INNOVATIVE MANIFOLD

SPRAY TIPS & BOOM PATTERN

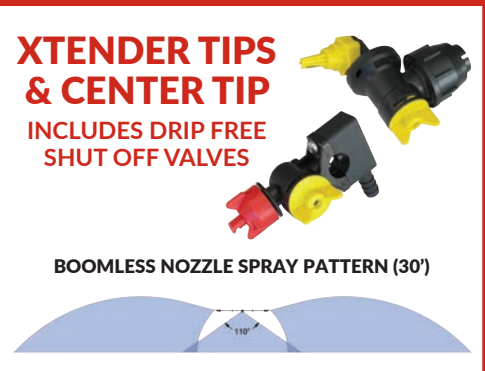
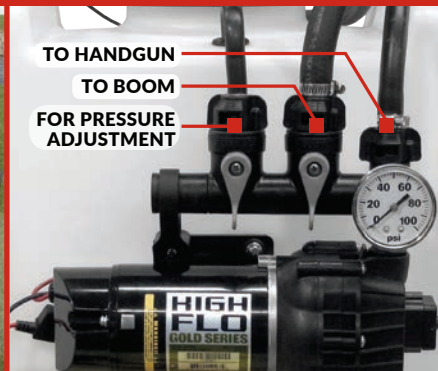

TO HANDGUN
TO BOOM
FOR PRESSURE ADJUSTMENT

XTENDER TIPS & CENTER TIP
INCLUDES DRIP FREE SHUT OFF VALVES

BOOMLESS NOZZLE SPRAY PATTERN (30')

Sprayer Weight	Water Weight	Sprayer W/Water Weight
82 lbs	334 lbs	416 lbs

LG-40-3PT-12V-BL

Model #	Code #	Tank Size	Shipping Weight	Carton Size	Shipping Class	Cubic Feet	UPS Able	UPC Code	List Price
LG-40-3PT-12V-BL	5302335	40 Gallon	90	40 x 24 x 24	150	13.4	139#	733029110732	\$ 891.00

PRO SERIES SPRAYERS
UTV SPRAYERS
SPOT SPRAYERS
ATV SPRAYERS
TRAILER SPRAYERS
UTILITY & 3PT SPRAYERS
SKID SPRAYERS & BOOMS
PUMPS
SPRAYER ACCESSORIES
DRY MATERIAL SPREADERS
TRAILER CARTS & AERATORS
SPRAYER COMPONENTS
PARTS/UST BREAKDOWNS

55 GALLON 3 POINT SPRAYERS



LG-55-3PT

SPRAY TIP OPTIONS & BOOM PATTERNS



XTENDER TIPS & CENTER TIP

INCLUDES DRIP FREE SHUT OFF VALVES



BOOMLESS NOZZLE SPRAY PATTERN (30')

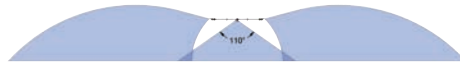

AIXR
PREMIUM
AIR INDUCED
INCLUDES NEW
ANTI-DRIP
STRAINER



7-NOZZLE BOOM SPRAY PATTERN (140")



LG-55-3PT & LG-55-3PT-BL

Sprayer Model	Sprayer Weight	Water Weight	Sprayer W/Water Weight
LG-55-3PT	176 lbs	459 lbs	635 lbs
LG-55-3PT-BL	157 lbs	459 lbs	616 lbs

Model #	Code #	Tank Size	Shipping Weight	Carton Size	Shipping Class	Cubic Feet	UPS Able	UPC Code	List Price
LG-55-3PT	5300576	55 Gallon	180	47 x 35 x 39	150	37	NO	733029001146	\$ 1,036.00
- Category 1, 3 Row, 7 Nozzle Boom, Less Pump									
LG-55-3PT-BL	5301383	55 Gallon	177	47 x 35 x 39	150	37	NO	733029003294	\$ 1,028.00

The LG-55-3PT-BL has a boomless nozzle with 30' coverage. Uses a 6 roller pump. Pump not included. Unit Weight 127 lbs.

OPTIONAL ACCESSORIES

Model #	Code #	Weight	Description	List Price
BB-308	5300675	7	Handgun Kit w/25' Hose	\$ 138.00
5271707	5271707	9	6 Roller Pump w/Coupler (540 RPM)	\$ 268.00

3 POINT SPRAYERS



5" FILL LID



SPRAY TIP OPTIONS & BOOM PATTERNS

XTENDER TIPS & CENTER TIP
INCLUDES DRIP FREE SHUT OFF VALVES

BOOMLESS NOZZLE SPRAY PATTERN (30')

AIXR PREMIUM AIR INDUCED
INCLUDES NEW ANTI-DRIP STRAINER

7-NOZZLE BOOM SPRAY PATTERN (140")

Sprayer Model	Sprayer Weight	Water Weight	Sprayer W/Water Weight
LG-60-3PT	210 lbs	500 lbs	710 lbs
LG-60-3PT-BL	195 lbs	500 lbs	695 lbs

LG-60-3PT

See Page 167 For Exploded View & Parts List

Model #	Code #	Tank Size	Shipping Weight	Carton Size	Shipping Class	Cubic Feet	UPS Able	UPC Code	List Price
LG-60-3PT	5301160	60 Gallon	265	45 x 41 x 40	150	43	NO	733029002617	\$ 1,290.00
LG-60-3PT-BL	5301340	60 Gallon	250	45 x 41 x 40	150	43	NO	733029003140	\$ 1,274.00

The LG-60-3PT-BL has a boomless nozzle with 30' coverage. Uses a 6 roller pump. Pump not included. Unit Weight 200 lbs.

OPTIONAL ACCESSORIES

Model #	Code #	Weight	Description	List Price
BB-309	5301253	6	Handgun Kit w/25' Hose	\$ 97.00
5271707	5271707	9	6 Roller Pump w/Coupler (540 RPM)	\$ 268.00

PRO SERIES SPRAYERS
UTV SPRAYERS
SPOT SPRAYERS
ATV SPRAYERS
TRAILER SPRAYERS
UTILITY & 3PT SPRAYERS
SKID SPRAYERS & BOOMS
PUMPS
SPRAYER ACCESSORIES
DRY MATERIAL SPREADERS
TRAILER CARTS & AERATORS
SPRAYER COMPONENTS
PARTS/ST BREAKDOWNS

110 & 150 GALLON 3 POINT SPRAYERS

COMPLETE SPRAYER CONSISTS OF:

- Carrier Cat 1 or 2
- Saddle
- Tank
- Plumbing Kit, Less Pump
- Boom Assembly



110 GALLON UNIT SHOWN

**SEE PAGES 65 TO 66
FOR BOOM SELECTION**

Model #	Code #	Tank Size	Shipping Weight	Carton Size	Shipping Class	Cubic Feet	UPS Able	UPC Code	List Price
5300438	5300438	110 Gallon	388	50 x 45 x 84	150	109.4	NA	733029001573	\$ 2,591.00
(1) 27-D 3 Point Carrier • (1) 30-110SB Saddle and Straps • (1) 5169003 110 Gal Poly Tank (1) 715-LP Roller Pump Kit Less Pump • (1) 257-8 8 Row Boom Assembly, 28 Ft With 17 Nozzles, AIXR Tips									

COMPLETE SPRAYER LESS PUMP (EXAMPLE)	Model #	Shipping Bundle #	Description	Unit Weight	List Price
	5300836		Complete 110 Gallon 3 Point Sprayer W/Boomless Nozzle • Same as 5300438 Except Uses • (1) M-122 Roller Pump Kit Less Pump • No Boom	190	\$ 1,908.00
	5300921		Complete 150 Gallon 3 Point Sprayer • (1) 27-D 3 Point Carrier • (1) 32-150SB Saddle & Straps • (1) 5169020 150 Gal Poly Tank • (1) 715-LP Roller Pump Kit Less Pump • (1) 257-8 8 Row Boom Assembly	307	\$ 2,863.00
	5301252		Complete 150 Gallon 3 Point Sprayer W/Boomless Nozzle • Same as 5300921 Except Uses • (1) M-122 Roller Pump Kit Less Pump • No Boom	225	\$ 2,138.00

ORDER COMPONENTS BY MODEL NO. INDIVIDUAL COMPONENTS FOR CUSTOMIZED SPRAYERS

CARRIER	27-D	5300061	3 Pt. CARRIER for 110 or 150 gal Poly Tank (Less Saddle & Straps) Category I & II	70	\$ 594.00
SADDLES	30-110SB	5300860	Saddle & Straps for 110 Gal Poly Tank (30")	36	\$ 232.56
	32-150SB	5300861	Saddle & Straps for 150 Gal Poly Tank (32")	54	\$ 278.16
TANKS	5169003	5169003	110 Gal Poly Tank (30")	41	\$ 326.58
	5169020	5169020	150 Gal Poly Tank (32")	54	\$ 394.62
PLUMBING KITS	M-122	5300584	Roller Pump Kit W/Boomless Nozzle, Less Pump		\$ 573.00
	715-LP	5300381	Roller Pump Kit, Less Pump	29	\$ 409.00

OPTIONAL EQUIPMENT

AGITATOR	814	5300025	Single Agitator Kit (Bottom Tank Mounting)	4	\$ 54.79
-----------------	-----	---------	--	---	----------

PRO SERIES SPRAYERS
UTV SPRAYERS
SPOT SPRAYERS
ATV SPRAYERS
TRAILER SPRAYERS
UTILITY & 3PT SPRAYERS
SKID SPRAYERS & BOOMS
PUMPS
SPRAYER ACCESSORIES
DRY MATERIAL SPREADERS
TRAILER CARTS & AERATORS
SPRAYER COMPONENTS
PARTSLIST BREAKDOWNS

200 - 300 GALLON 3 POINT SPRAYERS

COMPLETE SPRAYER CONSISTS OF:

- 3 Point Carrier, Category 1 & 2
- Saddle and Straps
- Roller Pump Kit w/Strainer & 8 Way Selector Valve or PTO Centrifugal Pump Kit w/1-1/4" Suction Hose, 8-Way Selector Valve, Strainer, Hoses. (Less Pump)
- Agitator Kit
- 8 or 10 Row Boom Assembly with Vari-Spacing Nylon Nozzles w/Tips
- 200 or 300 gallon Polyethylene Tank with (1) 3/4" & (1) 1-1/4" Bottom Fittings



**SEE PAGES 65 TO 66
FOR BOOM SELECTION**

Model #	Code #	Tank Size	Shipping Weight	Carton Size	Shipping Class	Cubic Feet	UPS Able	UPC Code	List Price
5300758	5300758	200 Gallon	511	90 x 48 x 53	150	132.6	NA	733029002778	\$ 3,096.00
(1) BB-32 3 Point Carrier • (1) 38-200SB Saddle and Strap Assembly • (1) 5169004 200 Gallon Poly Tank (1) 715-LP Plumbing & Hose Kit Less Pump • (1) 814 Agitator, Kit • (1) 257-8 Boom Assembly, 28 Ft With 17 Nozzles, AIXR Tips									

Model #	Code #	Tank Size	Shipping Weight	Carton Size	Shipping Class	Cubic Feet	UPS Able	UPC Code	List Price
5300653	5300653	300 Gallon	606	90 x 48 x 53	150	132.6	NA	733029001597	\$ 3,500.00
(1) BB-32 3 Point Carrier • (1) 38-300SB Saddle and Strap Assembly • (1) 5169002 300 Gallon Poly Tank (1) 715-LP Plumbing & Hose Kit Less Pump • (1) 814 Agitator Kit • (1) 257-8 Boom Assembly, 28 Ft With 17 Nozzles, AIXR Tips									

	Model #	Shipping Bundle #	Description	Unit Weight	List Price
COMPLETE SPRAYER LESS PUMP (EXAMPLE)		5300826	Complete 200 Gallon 3 Point Sprayer W/Boomless Nozzle • Same as 5300758 Except Uses • (1) M-122 Roller Pump Kit Less Pump • No Boom Or Agitator Kit	338	\$ 2,368.00
		5300827	Complete 300 Gallon 3 Point Sprayer W/Boomless Nozzle • Same as 5300653 Except Uses • (1) M-122 Roller Pump Kit Less Pump • No Boom Or Agitator Kit	378	\$ 2,762.00

ORDER COMPONENTS BY MODEL NO. INDIVIDUAL COMPONENTS FOR CUSTOMIZED SPRAYERS

CARRIER	BB-32	5300374	3 Point Carrier less Saddle Category I & II (Carries 200 or 300 Gal Poly Tank)	178	\$ 861.00
SADDLES	38-200SB	5300863	Saddle & Straps for (38") 200 Gal Poly Tank	57	\$ 304.38
	38-300SB	5300864	Saddle & Straps for (38") 300 Gal Poly Tank	100	\$ 555.18
TANKS	5169004	5169004	200 Gal Poly Tank (38" x 50")	56	\$ 477.72
	5169002	5169002	300 Gal Poly Tank (38" x 75")	81	\$ 614.63
PLUMBING KITS	M-122	5300584	Roller Pump Kit W/Boomless Nozzle, Less Pump		\$ 573.00
	715-LP	5300381	Roller Pump Kit, Less Pump	29	\$ 409.00
	716-LP	5300032	Centrifugal Pump Kit Less Pump	46	\$ 504.00
	716-3EG-12LP	5300034	Centrifugal Pump Kit Less Pump w/Electric Pressure Control	54	\$ 1,431.00
AGITATOR	814	5300025	Single Agitator Kit (Bottom Tank Mounting)	4	\$ 54.79
			OPTIONAL EQUIPMENT		
	812	5300024	Dual Agitator Kit (Bottom Tank Mounting)	5	\$ 112.78

300, 400 & 500 GALLON 3 POINT SPRAYERS

COMPLETE SPRAYER CONSISTS OF:

- Carrier
- Saddle
- Tank
- Plumbing Kit, Less Pump
- Boom Assembly
- Agitator Kit



**SEE PAGES 65 TO 66
FOR BOOM SELECTION**

	Model #	Shipping Bundle #	Description	Unit Weight	List Price
COMPLETE SPRAYER LESS PUMP (EXAMPLE)		5300820	Complete 500 Gallon 3 Point Sprayer <ul style="list-style-type: none"> • (1) 31-F45 3 Point Carrier • (1) 48-500 Saddle & Straps • (1) 5169030 500 Gallon Poly Tank • (1) 716-LP Centrifugal Plumbing Kit Less Pump • (1) 1210 (10 Row) Boom Assembly; 35 Ft With 21 Nozzles. AIXR Tips • (1) 812 Agitator Kit 	1,066	\$ 8,994.66

ORDER COMPONENTS BY MODEL NO. INDIVIDUAL COMPONENTS FOR CUSTOMIZED SPRAYERS

CARRIER	31-F45	5300375	3 Point Carrier less Saddle Category III (For 300, 400 or 500 Gal Poly Tank)	325	\$ 2,178.60
SADDLES	300E-SB	5301509	Saddle & Straps for 300 Gal Elliptical Tank	100	\$ 380.76
	42-400-SB	5300865	Saddle & Straps for 400 Gal (42") Poly Tank	130	\$ 513.00
	48-500-SB	5300866	Saddle & Straps for 500 Gal (48") Poly Tank	138	\$ 538.08
TANKS	5169081		300 Gal Elliptical Tank 30" High-48" Wide-66" Long	81	\$ 768.64
	5169029		400 Gal Round Tank 42" x 80"	101	\$ 854.11
	5169030		500 Gal Round Tank 48" x 74"	118	\$ 966.34
PLUMBING KITS	715-LP	5300381	Roller Pump Kit, Less Pump	29	\$ 409.00
	716-LP	5300032	Centrifugal Pump Kit Less Pump	46	\$ 504.00
	716-3EG-12LP	5300034	Centrifugal Pump Kit Less Pump w/Electric Pressure Control	54	\$ 1,431.00
AGITATOR	812	5300024	Dual Agitator Kit (Bottom Tank Mounting)	5	\$ 112.78

(UTL) UTILITY VEHICLE SPRAYERS

8' 16 Gauge Lead Wire With Quick Coupler, In-Line On/Off Switch & Deluxe Battery Clips

Innovative Manifold With On/Off Valves For Pressure/Control & Boom Operation

Pistol Grip Handgun With 35' Horizontal & 26' Vertical Spray

5" Fill Lid

60 Gallon Poly Tank

UTL-60-12V-BL with the boomless nozzle configuration

All 3 Nozzles Have Built-In Drip Free Shutoff Valves To Spray From 6' To 30'

UTL-40-12V shown - 5 Nozzle configuration

3.8 GPM High-Flo 12V Pump; 45 PSI; 11 Amp

SPRAY TIP OPTIONS & BOOM PATTERNS

AIXR PREMIUM AIR INDUCED
INCLUDES NEW ANTI-DRIP STRAINER



5-NOZZLE BOOM SPRAY PATTERN (100")



AIXR PREMIUM AIR INDUCED
INCLUDES NEW ANTI-DRIP STRAINER



7-NOZZLE BOOM SPRAY PATTERN (140")



XTENDER TIPS & CENTER TIP
INCLUDES DRIP FREE SHUT OFF VALVES



BOOMLESS NOZZLE SPRAY PATTERN (30')

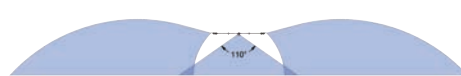

Sprayer Model	Sprayer Weight	Water Weight	Sprayer W/Water Weight
UTL-40-5	115 lbs	334 lbs	449 lbs
UTL-40-12V	112 lbs	334 lbs	446 lbs
UTL-40-12V-BL	106 lbs	334 lbs	440 lbs
UTL-60-12V	121 lbs	500 lbs	621 lbs
UTL-60-7	133 lbs	500 lbs	633 lbs
UTL-60-12V-BL	114 lbs	500 lbs	614 lbs

UTL-40-5, UTL-40-12V, UTL-40-12V-BL, UTL-60-12V, UTL-60-7, UTL-60-12V-BL

Model #	Code #	Pump Size	Boom	Tank Size	Shipping Weight	Carton Size	Shipping Class	Cubic Feet	UPS Able	UPC Code	List Price
UTL-40-5	5301399	2.1 GPM	5 Nozzle	40 Gallon	167	44 x 44 x 36	150	40.4	NO	733029003355	\$ 1,040.00
UTL-40-12V	5301343	3.8 GPM	5 Nozzle	40 Gallon	164	44 x 44 x 36	150	40.4	NO	733029003379	\$ 1,104.00
UTL-40-12V-BL	5301344	3.8 GPM	Boomless	40 Gallon	158	44 x 44 x 30	150	33.7	NO	733029003386	\$ 1,104.00
UTL-60-12V	5301347	3.8 GPM	5 Nozzle	60 Gallon	173	44 x 44 x 36	150	40.4	NO	733029003416	\$ 1,124.00
UTL-60-7	5301400	3.8 GPM	7 Nozzle	60 Gallon	185	44 x 44 x 36	150	40.4	NO	733029003362	\$ 1,186.00
UTL-60-12V-BL	5301348	3.8 GPM	Boomless	60 Gallon	166	44 x 44 x 30	150	33.7	NO	733029003423	\$ 1,124.00



WHAT OPTIONS ARE AVAILABLE FOR YOUR SKID SPRAYER?



PRO SERIES SPRAYERS
UTV SPRAYERS
SPOT SPRAYERS
ATV SPRAYERS
TRAILER SPRAYERS
UTILITY & 3PT SPRAYERS
SKID SPRAYERS & BOOMS
PUMPS
SPRAYER ACCESSORIES
DRY MATERIAL SPREADERS
TRAILER CARTS & AERATORS
SPRAYER COMPONENTS
PARTSLIST BREAKDOWNS

HOSE REELS

ENGINES



ELECTRIC REELS



HAND CRANK REELS



HANDGUNS

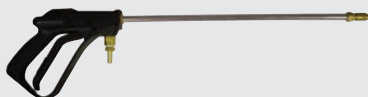

PISTOL GRIP HANDGUN



ALUMINUM HANDGUN



PRO SERIES LONG RANGE HANDGUN

12 VOLT SKID SPRAYERS



SK-61-12V

INNOVATIVE MANIFOLD

8 FT 16 GAUGE LEAD WIRE

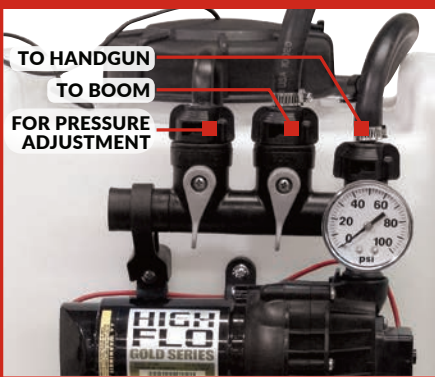

With Quick Coupler, In-Line On/Off Switch & Deluxe Battery Clips

SK-61-12V

Sprayer Weight	Water Weight	Sprayer W/Water Weight
126 lbs	500 lbs	626 lbs

Model #	Code #	Tank Size	Shipping Weight	Carton Size	Shipping Class	Cubic Feet	UPS Able	UPC Code	List Price
SK-61-12V	5301304	60 Gallon	180	65 x 26 x 31	150	30.4	NO	733029003225	\$ 895.00

OPTIONAL ACCESSORIES

Model #	Code #	Weight	Description	List Price
T-62	5301394	57	Trailer Kit (15/600 Tires)	\$ 399.00
T-62-HD	5301471	77	Heavy Duty Trailer Kit (18 x 850 x 8 Tires)	\$ 530.00
BK-2-61	5301468	15	2 Nozzle Boom Kit (80" Coverage)	\$ 114.00
BK-4-61	5301469	25	5 Nozzle Boom Kit (100" Coverage)	\$ 250.00
BK-7-61	5301470	33	7 Nozzle Boom Kit (140" Coverage)	\$ 293.00

GAS SKID SPRAYERS



SK-61-4R

127cc BRIGGS GAS ENGINE

163cc HONDA GAS ENGINE



Sprayer Model	Sprayer Weight	Water Weight	Sprayer W/Water Weight
SK-61-4R	151 lbs	500 lbs	651 lbs
SK-61-4R-HR	186 lbs	500 lbs	686 lbs
SK-61-6R-HON	160 lbs	500 lbs	660 lbs

SK-61-4R

Model #	Code #	Tank Size	Shipping Weight	Carton Size	Shipping Class	Cubic Feet	UPS Able	UPC Code	List Price
SK-61-4R	5301336	60 Gallon	185	65 x 26 x 31	150	30.4	NO	733029003102	\$ 1,711.00
SK-61-4R-HR	5301379	60 Gallon	215	65 x 26 x 31	150	30.4	NO	733029003768	\$ 2,170.00
SK-61-6R-HON	5301518	60 Gallon	232	65 x 26 x 31	150	30.4	NO	733029005137	\$ 2,631.00

OPTIONAL ACCESSORIES

Model #	Code #	Weight	Description	List Price
T-62	5301394	57	Trailer Kit (15/600 Tires)	\$ 399.00
T-62-HD	5301471	77	Heavy Duty Trailer Kit (18 x 850 x 8 Tires)	\$ 530.00
BK-2-61	5301468	15	2 Nozzle Boom Kit (80" Coverage)	\$ 114.00
BK-4-61	5301469	25	5 Nozzle Boom Kit (100" Coverage)	\$ 250.00
BK-7-61	5301470	33	7 Nozzle Boom Kit (140" Coverage)	\$ 293.00

FIREFIGHTING SKID SPRAYER

Electric Rewind Hose Reel With
Spool Kit 300' of 600 PSI, 1/2" PVC Hose

16" Fill Lid

300 Gallon
Poly Tank



163cc Honda Gas Engine, 3 Diaphragm Pump
- 10.6 GPM With 580 PSI

Heavy Duty Aluminum Pistol Grip Handgun With
49' Horizontal & 37' Vertical Spray, Pressure to 800 PSI

Sprayer Weight	Water Weight	Sprayer W/Water Weight
586 lbs	2502 lbs	3088 lbs

TSSK-300

163cc HONDA GAS ENGINE

ADDITIONAL HANDGUN



The TSSK-300 Also Comes With
The TeeJet 25660 Lawn Gun

**USED FOR LAWN SERVICES, FIRE FIGHTING
& MANY OTHER APPLICATIONS**

TSSK-300

Model #	Code #	Tank Size	Shipping Weight	Shipping Class	UPS Able	UPC Code	List Price
TSSK-300	5301337	300 Gallon	470	250	NO	733029003164	\$ 9,011.00

FIREFIGHTING SKID SPRAYERS

200 Gallon Poly Tank

16" Fill Lid

Hand Rewind Hose Reel
300' of 600 PSI, 1/2" Rubber Braid Hose

205cc Briggs, 163cc Honda, Or 196cc Power Pro Gas Engine

Heavy Duty Aluminum Pistol Grip Handgun With 49' Horizontal & 37' Vertical Spray, Pressure to 800 PSI

8 Roller Pump

EXCELLENT IN HELPING TO CONTROL GRASS FIRES OTHER TYPES OF FIRES

LSS-235-H & LSS-240	LSS-280
 PISTOL GRIP HANDGUN	
SPRAY DISTANCE 49 FT HORIZONTAL 37 FT VERTICAL	SPRAY DISTANCE 45 FT HORIZONTAL 33 FT VERTICAL

Sprayer Model	Sprayer Weight	Water Weight	Sprayer W/Water Weight
LSS-235-H	396 lbs	1668 lbs	2064 lbs
LSS-240	401 lbs	1668 lbs	2069 lbs
LSS-280	396 lbs	1668 lbs	2064 lbs
LSS-280-E	396 lbs	1668 lbs	2064 lbs
LSS-280-EH	401 lbs	1668 lbs	2069 lbs
LSS-280-H	396 lbs	1668 lbs	2064 lbs

Model #	Code #	Tank Size	Shipping Weight	Carton Size	Shipping Class	Cubic Feet	UPS Able	UPC Code	List Price
LSS-240	5301259	200 Gallon	500	79 x 41 x 49	150	91.0	NA	733029004352	\$ 6,304.00
196cc Power Pro Recoil Start Engine • Three Diaphragm Pump - 580 P.S.I. - 10 G.P.M. • Hand Rewind Hose Reel • 300 Ft. of 600 P.S.I. Working Pressure PVC Hose • Tank Equipped with Agitator • Heavy Duty Pistol Grip Handgun • 37 Ft. Vertical Spray Height									
LSS-235-H	5301869	200 Gallon	518	79 x 41 x 49	150	91.0	NA	733029008787	\$ 7,827.00
163cc Honda Engine & Electric Hose Reel									
LSS-280	5300467	200 Gallon	500	79 x 41 x 49	150	91.0	NA	733029001139	\$ 4,210.00
205cc Briggs & Stratton Recoil Start Engine • 8 Roller Pump - 0-150 P.S.I. - 7.8 G.P.M. • Hand Rewind Hose Reel 300 Ft. of 1/2" 2 Braid Rubber Hose • Tank Equipped with Agitator • Heavy Duty Pistol Grip Handgun									
LSS-280-H	5301865	200 Gallon	500	79 x 41 x 49	150	91.0	NA	733029008749	\$ 4,748.00
163cc Honda Engine									
LSS-280-E	5301866	200 Gallon	518	79 x 41 x 49	150	91.0	NA	733029008756	\$ 5,380.00
205cc Briggs Engine & Electric Hose Reel									
LSS-280-EH	5301867	200 Gallon	518	79 x 41 x 49	150	91.0	NA	733029008763	\$ 5,806.00
163cc Honda Engine & Electric Hose Reel									

PRO SERIES SPRAYERS
UTV SPRAYERS
SPOT SPRAYERS
ATV SPRAYERS
TRAILER SPRAYERS
UTILITY & 3PT SPRAYERS
SKID SPRAYERS & BOOMS
PUMPS
SPRAYER ACCESSORIES
DRY MATERIAL SPREADERS
TRAILER CARTS & AERATORS
SPRAYER COMPONENTS
PARTS LIST BREAKDOWNS

SKID MOUNTED SPRAYERS

COMPLETE SPRAYER CONSISTS OF:

- 150 Gallon Polyethylene Tank
- Adjustable Pressure - Pressure Gauge
- Suction Line Filter
- Handgun - 25 Foot Handgun hose
- Optional Trailer & Boom Assembly Available
- 205cc Briggs & Stratton Gas Engine



PISTOL GRIP HANDGUN

SPRAY DISTANCE
45 FT HORIZONTAL
33 FT VERTICAL

Sprayer Weight	Water Weight	Sprayer W/Water Weight
202 lbs	1251 lbs	1453 lbs

Model #	Code #	Tank Size	Shipping Weight	Carton Size	Shipping Class	Cubic Feet	UPS Able	UPC Code	List Price
9-150	5300431	150 Gallon	314	79 x 41 x 49	150	91.9	NO	733029001214	\$ 2,848.00

OPTIONAL ACCESSORIES FOR 150 GAL SKIDS

Model #	Shipping Bundle #	Description	Unit Weight	List Price
T-65	5300428	Trailer Kit for 150 Gal Skid Sprayer w/ 4 Bolt 15" Wheels (Less Tires)	85	\$ 801.00
BK-6	5300260	Boom Assy w/ 13 Vari-Spacing Nozzles, 21' Coverage	90	\$ 1,027.14
T-61	5301234	Trailer Kit For Skid Sprayer w/18 x 850-8 Turf Wheels (Off-Road)	100	\$ 703.00

COMPLETE SPRAYER CONSISTS OF:

- 110, 200 Or 300 Gallon Polyethylene Tank
- Adjustable Pressure - Pressure Gauge
- Suction Line Filter
- Handgun - 25 Foot Handgun hose
- Optional Trailer & Boom Assembly Available
- 205cc Briggs & Stratton Gas Engine
- 150 PSI, 7.9 GPM



Sprayer Model	Sprayer Weight	Water Weight	Sprayer W/Water Weight
SK-110-8R	225 lbs	917 lbs	1142 lbs
9-200	294 lbs	1668 lbs	1962 lbs
9-300	254 lbs	2502 lbs	2756 lbs

Model #	Shipping Bundle #	Description	Shipping Weight	Unit Weight	List Price
SK-110-8R	5301052	110 Gallon Poly Tank Skid Sprayer	279	229	\$ 2,627.00
9-200	5300655	200 Gallon Poly Tank Skid Sprayer	336	286	\$ 3,031.00
9-300	5300656	300 Gallon Poly Tank Skid Sprayer	415	365	\$ 3,539.00

HOSE REELS

LOW PRESSURE COX REEL

- Heavy duty 1/4" plate steel support post and mounting plate
- 1" Oil-lite self lubricating bearing
- Solid 1" steel center support shaft
- Full flow swivel joint
- Adjustable arm guide (wall, floor, ceiling and pit)
- Cartridge style spring motor
- 4 Roller non-s snag hose guide
- Eight position locking ratchet



MFG Part #	FIMCO Part #	Hose ID	Hose OD	Ft	PSI	List Price
P-LP-350	5274152	3/8"	21/32"	50	300	\$ 677.41
P-LP-415	5274153	1/2"	27/32"	15	300	\$ 548.48

COX HAND CRANK REEL



MFG Part #	FIMCO Part #	Inlet/Outlet	Reel Capacity In Feet	PSI	List Price
1125-4-325	5274304	1/2"	450' of 3/8" 325' of 1/2"	3000	\$ 572.01

COX 12 VOLT ELECTRIC REEL (Gear Driven)

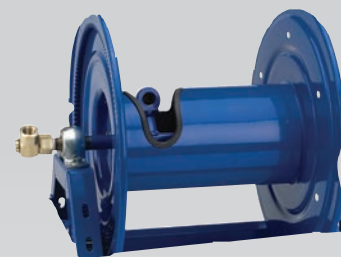

MFG Part #	FIMCO Part #	Inlet/Outlet	Reel Capacity In Feet	PSI	List Price
1125-4-325E	5274305	1/2"	450' of 3/8" 325' of 1/2"	3000	\$ 1,319.74

1526-17-18

- 1/2 FNPT Inlet & Outlet
- Holds 300 Ft of 1/2" ID. x 7/8" OD. Hose
- 3000 PSI Max. Pressure
- Temperature Range -20° to 400°
- Optional Guide Rollers & Mounting Bracket



GENERAL PUMP HAND CRANK REEL



MFG Part #	FIMCO Part #	Inlet/Outlet	Reel Capacity In Feet	PSI	List Price
D30006	5277374	3/8" NPT-M 3/8" NPT-F	200' of 3/8"	3500	\$ 291.20

MANUAL REWIND HOSE REELS	Model #	Shipping Bundle #	Description	Weight	List Price
	1526-17-18	5272182	Hannay Manual Rewind Hose Reel Crank is Permanently Attached to the Reel Axle on this Model	38	\$ 635.95

OPTIONS	Model #	Shipping Bundle #	Description	Weight	List Price
	5274195-BLK	5274195	Mounting Stand for Hose Reels		\$ 204.00

PRO-SERIES BOOM ASSEMBLIES



**AIXR
PREMIUM
AIR INDUCTED**
INCLUDES NEW
ANTI-DRIP STRAINER



- Adjustable Spacing Nozzles 20" Spacing Standard
- Adjustable Height
- 4-Way Hinge For Boom Protection
- Cross Over Folding With Center Support & Lock For Low Profile Transport
- Welded Square Tube Boom Sections For Strength
- Nozzle Harness Assemblies Come Complete With Cap, Tip & Strainers
- Diaphragm Check Valve Nozzle Harnesses Are Optional

This high quality boom comes in a 6 row (21' - 13 nozzle), 8 row (28' - 17 nozzles) or 10 row (35' - 21 nozzles) lengths.

They come complete with nozzle harness assemblies and upright mounting angles.

PRO-SERIES-21, -28, & -35

Model #	Code #	Tank Size	Shipping Weight	Carton Size	Shipping Class	Cubic Feet	UPS Able	UPC Code	List Price
PRO-SERIES-21-QJ	5301353	6 Row	188	94 x 27 x 10	150	14.7	NA	733029004185	\$ 1,303.00
PRO-SERIES-28-QJ	5301354	8 Row	203	94 x 27 x 10	150	14.7	NA	733029004192	\$ 1,477.00
PRO-SERIES-35-QJ	5301355	10 Row	230	94 x 27 x 10	150	14.7	NA	733029004185	\$ 1,686.00

PRO SERIES SPRAYERS
UTV SPRAYERS
SPOT SPRAYERS
ATV SPRAYERS
TRAILER SPRAYERS
UTILITY & 3PT SPRAYERS
SKID SPRAYERS & BOOMS
PUMPS
SPRAYER ACCESSORIES
DRY MATERIAL SPREADERS
TRAILER CARTS & AERATORS
SPRAYER COMPONENTS
PARTS/LIST BREAKDOWNS

SERIES 257 BOOM ASSEMBLIES



AIXR
PREMIUM
AIR INDUCTED

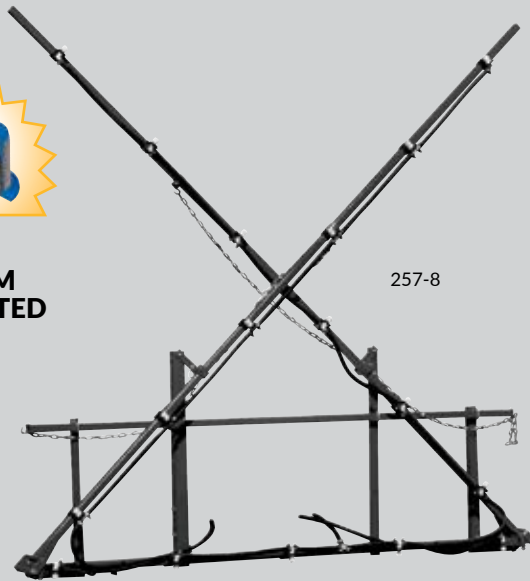

SPECIFICATIONS

- Adjustable spacing nozzles
- Height adjustment
- 4-Way hinge for boom protection
- Cross over folding
- Caps, strainers and tips standard
- Square tube boom construction
- Diaphragm check valve nozzles - optional

	Model #	Shipping Bundle #	Description	Unit Weight	List Price
6 ROW QUICKJET	257-6	5300424	6 Row, 21 Foot Boom W/13 Nozzles Includes The Following: 5300343257 Back Rack Bundle 53003486 Row Outer Boom Bundle 5300351Nozzle Harness W/ AIXR11003VP Tips	82	\$ 1,014.00
6 ROW DIAPHRAGM	257-6QJD	5300693	6 Row, 21 Foot Boom W/13 Nozzles Includes The Following: 5300343257 Back Rack Bundle 53003486 Row Outer Boom Bundle 5300702Nozzle Harness W/QuickJet Diaphragm Nozzles W/ AIXR11003VP Tips	82	\$ 1,083.00
8 ROW QUICKJET	257-8	5300658	8 Row, 28 Foot Boom W/17 Nozzles Includes The Following: 5300343257 Back Rack Bundle 53003448 Row Outer Boom Bundle 5300336Nozzle Harness W/ AIXR11003VP Tips	96	\$ 1,018.00
8 ROW DIAPHRAGM	257-8QJD	5300694	8 Row, 28 Foot Boom W/17 Nozzles Includes The Following: 5300343257 Back Rack Bundle 53003448 Row Outer Boom Bundle 5300355Nozzle Harness W/QuickJet Diaphragm Nozzles W/ AIXR11003VP Tips	96	\$ 1,296.00
10 ROW QUICKJET	257-10	5300426	10 Row, 35 Foot Boom W/21 Nozzles Includes The Following: 5300343257 Back Rack Bundle 530034910 Row Outer Boom Bundle 5300350Nozzle Harness W/ AIXR11003VP Tips	110	\$ 1,110.00
10 ROW DIAPHRAGM	257-10QJD	5300695	10 Row, 35 Foot Boom W/21 Nozzles Includes The Following: 5300343257 Back Rack Bundle 530034910 Row Outer Boom Bundle 5300360Nozzle Harness W/QuickJet Diaphragm Nozzles W/ AIXR11003VP Tips	110	\$ 1,485.00

SERIES 1200 & SERIES 1357 BOOM ASSEMBLIES



SERIES 1200

- Square tube construction
- Shock absorbers on boom for easy flotation
- Low profile for transport
- Diaphragm check valve nozzles optional
- Adjustable spacing nozzles
- Height adjustment
- 4-Way hinge for boom protection
- Cross over folding
- Caps, strainers and tips standard



AIXR
PREMIUM
AIR INDUCED

	<u>Model #</u>	<u>Shipping Bundle #</u>	<u>Description</u>	<u>Unit Weight</u>	<u>List Price</u>
12 ROW QUICKJET 42 ft. Boom	1212	5300448	12 Row (5 Section) Boom Ass'y W/1-1/4" Square Tube W/Shock Absorbers & 25 Nozzles	268	\$ 2,800.00
12 ROW DIAPHRAGM 42 ft. Boom	1212QJD	5300698	12 Row (5 Section) Boom Ass'y W/1-1/4" Square Tube W/Shock Absorbers & 25 Nozzles	268	\$ 3,315.20
OPTION	FB-14	5300669	Hydraulic Height Adjustment Self-Leveling Boom Attachment w/Shock-Absorbers & Springs Gives Additional Cushion To Boom On Rough Terrain At High Speed (Lifts 20")	110	\$ 2,019.20

SERIES 1357

- Square Tube Construction
- Height Adjustment
- Adjustable Spacing Nozzles
- Cross Over Folding-Low Profile for Transport
- 4 Way Breakaway Hinge for Boom Protection
- Tips, Caps, & Strainers Standard



12 ROW QUICKJET 25 Nozzles	1357-12QJD	5300699	42 Ft. Heavy Duty 12 Row Boom - 5 Sections Folds Behind Sprayer - 3/4" Nozzle Harness Included	434	\$ 5,776.00
14 ROW QUICKJET 29 Nozzles	1357-14QJD	5300700	48 Ft. Heavy Duty 14 Row Boom - 5 Sections Folds Behind Sprayer - 3/4" Nozzle Harness Included	444	\$ 5,955.20
OPTIONAL HYDRAULIC LIFT KIT	HL-1357	5300719	Hydraulic Lift Kit Pivots The Outer Booms Up and Down On 1357 Series Booms. Includes (2) Hydraulic Cylinders and Attaching Hardware	60#	\$ 796.80
OPTION	FB-14	5300669	Hydraulic Height Adjustment Self-Leveling Boom Attachment w/Shock-Absorbers & Springs Gives Additional Cushion To Boom On Rough Terrain At High Speed (Lifts 20")	110	\$ 2,019.20

OPTIONAL HYDRAULIC LIFT KIT & HANDGUNS



BB 300 HANDGUN KIT

Includes 25' 3/8" 2 Braid Hose, Model 43-AL Aluminum HandGun, Brass Shutoff Valve.

5300199 \$ 235.91

OPTIONAL HYDRAULIC LIFT KIT (FITS SERIES 1200 & 1357 BOOMS)	Model #	Shipping Bundle #	Description	Unit Weight	List Price
	FB-14	5300669	Hydraulic Height Adjustment, Self-Leveling, Boom Attachment w/Shock-Absorbers and Springs Gives additional Cushion to Boom on Rough Terrain at High Speed, (Lifts 20")	110	\$ 2,019.20



ES-132C

ROLLER & DIAPHRAGM PUMP KITS

For low to moderate volume and pressure spraying of fence rows, livestock, and orchards. All iron construction - Super Rollers - Stainless Steel Shafts. Models ES-131, & ES-132, Include base plate, Engine, Pump, Hand Gun w/25' Hose, Manifold, Gauge, Bypass, and Suction Hose.

Model #	Code #	Pump Description	HP	GPM	PSI	WT	List Price
ES-131	5300280	Hypro 4 Roller Pump Direct Driven at 2600 RPM	127cc Briggs	5.4	150	77	\$ 1,727.00
ES-132C	5300058	Hypro 8 Roller Pump Direct Driven at 600 RPM	205cc Briggs	7.8	300	93	\$ 1,775.00
G-4101C	5300473	Same as ES-131 Less Manifold, Gauge, Handgun, and All Hose	127cc Briggs	5.4	150	67	\$ 718.00
G-7560CR	5300475	Same as ES-132 Less Manifold, Gauge, Handgun, and All Hoses	205cc Briggs	7.8	300	77	\$ 2,691.07

PRO SERIES SPRAYERS
UTV SPRAYERS
SPOT SPRAYERS
ATV SPRAYERS
TRAILER SPRAYERS
UTILITY & 3PT SPRAYERS
SKID SPRAYERS & BOOMS
PUMPS
SPRAYER ACCESSORIES
DRY MATERIAL SPREADERS
TRAILER CARTS & AERATORS
SPRAYER COMPONENTS
PARTSLIST BREAKDOWNS

PRO SERIES HIGH-FLO 12 VOLT PUMPS



HFP-2.2 G.P.M.



- High-Flo 12 Volt Pro Series Pump; 2.2 GPM
- Professional Grade Pump Upgraded Elastomers - Ideal For:
 - Harsh Chemicals
 - Oil Based Chemicals With Surfactants
- Heavy Duty Motor
- 100 PSI
- Viton Valves
- Geolast Diaphragm
- Two Pin Connector 6" Long
- 1/2"-14NPT Male Threads
- **DO NOT USE With Flammable Or Combustible Liquids**

Boxed Part #	Individual Part #	Volts	Amps	Demand Switch or Relief Valve	Max Pressure	GPM	UPC Code	List Price
5281325	5151075	12	4	Demand Switch	100	2.2	733029117601	Call For Pricing

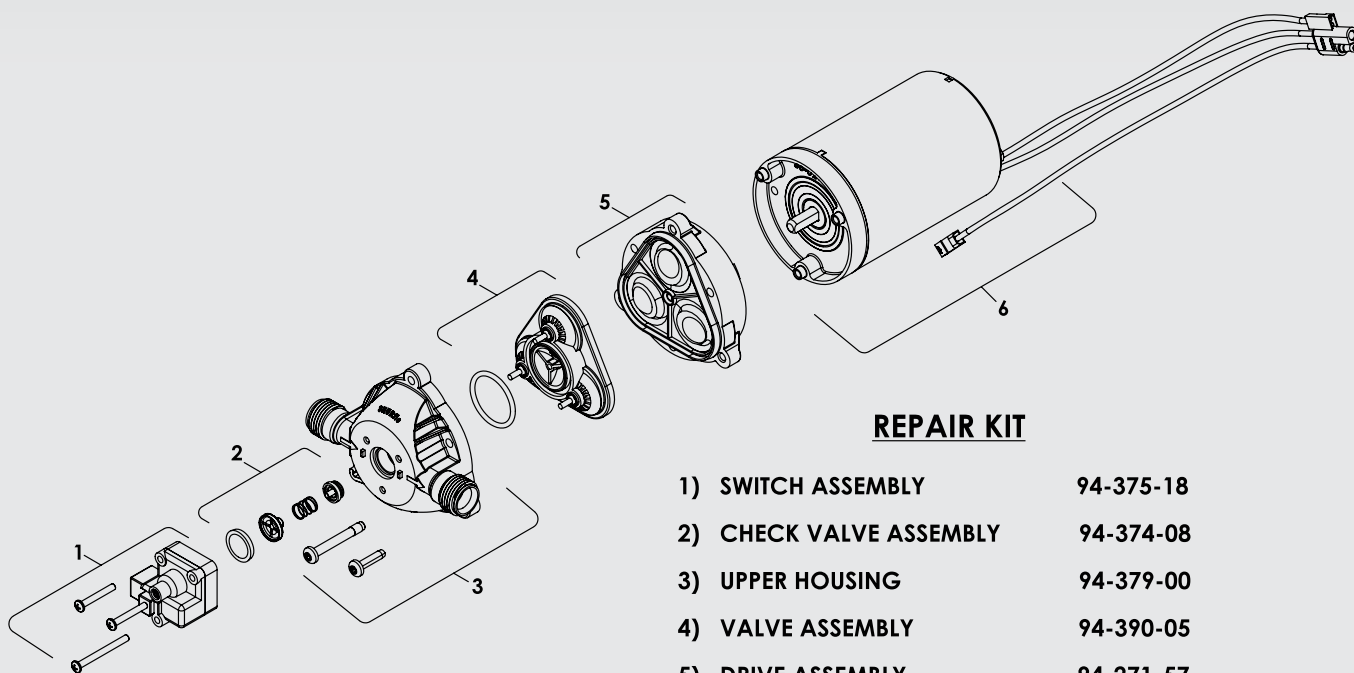

REPAIR KIT

- | | |
|-------------------------|--------------|
| 1) SWITCH ASSEMBLY | 94-375-18 |
| 2) CHECK VALVE ASSEMBLY | 94-374-08 |
| 3) UPPER HOUSING | 94-379-00 |
| 4) VALVE ASSEMBLY | 94-390-05 |
| 5) DRIVE ASSEMBLY | 94-271-57 |
| 6) MOTOR | 94-11-111-04 |

PRO SERIES SPRAYERS
UTV SPRAYERS
SPOT SPRAYERS
ATV SPRAYERS
TRAILER SPRAYERS
UTILITY & 3PT SPRAYERS
SKID SPRAYERS & BOOMS
PUMPS
SPRAYER ACCESSORIES
DRY MATERIAL SPREADERS
TRAILER CARTS & AERATORS
SPRAYER COMPONENTS
PARTS/ST BREAKDOWNS

PRO SERIES HIGH-FLO 12 VOLT PUMPS



HFP-4.0 G.P.M.



- High-Flo 12 Volt Pro Series Pump; 4.0 GPM
- Professional Grade Pump Upgraded Elastomers - Ideal For:
 - Harsh Chemicals
 - Oil Based Chemicals With Surfactants
- Heavy Duty Motor
- 45 PSI
- Viton Valves
- Geolast Diaphragm
- Two Pin Connector 6" Long
- 1/2"-14NPT Male Threads
- **DO NOT USE With Flammable Or Combustible Liquids**

Boxed Part #	Individual Part #	Volts	Amps	Demand Switch or Relief Valve	Max Pressure	GPM	UPC Code	List Price
5281326	5151073	12	11	Demand Switch	60	4.0	733029117618	Call For Pricing

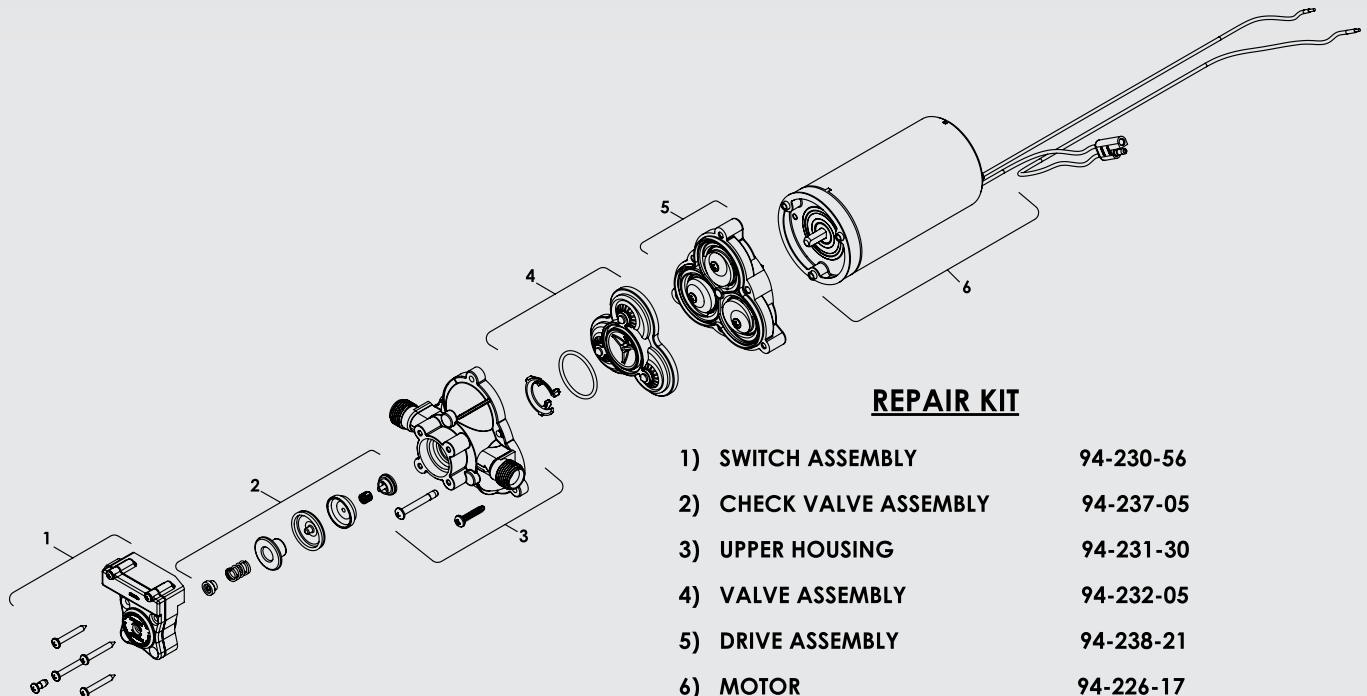

PRO SERIES SPRAYERS
UTV SPRAYERS
SPOT SPRAYERS
ATV SPRAYERS
TRAILER SPRAYERS
UTILITY & 3PT SPRAYERS
SKID SPRAYERS & BOOMS
PUMPS
SPRAYER ACCESSORIES
DRY MATERIAL SPREADERS
TRAILER CARTS & AERATORS
SPRAYER COMPONENTS
PARTS LIST BREAKDOWNS

HIGH-FLO 12 VOLT PUMPS



1.0 G.P.M.



- 12 Volt Diaphragm Pump
- 1.0 G.P.M.
- 35 P.S.I. Max Pressure
- 4 Amp Draw
- Ready For Round-up®
- **DO NOT USE with Flammable or Combustible Liquids**

- DEMAND SWITCH MODELS operate only when liquid flow is required. Pump and motor stop instantly when discharge is closed.
- Diaphragm design eliminates troublesome shaft seal.
- Pump can be run indefinitely without damage.

- Ball bearing drive - assures longer pump life.
- Excellent self-priming capability.
- Santoprene diaphragms and viton valves are standard.
- Maximum temperature of pumped liquid 130°F.
- Permanent magnet motor - long life brushes.

- Fuse Protected
- Built-In cooling fan

Boxed Part #	Individual Part #	Volts	Amps	Demand Switch or Relief Valve	Max Pressure	GPM	UPC Code	List Price
5275086	5277980	12	4.0	Demand Switch	35	1	733029101846 (Boxed)	\$ 104.42

Pump Model: 5277980

12 Volt, 4 Amp, 1.0 G.P.M., 35 P.S.I.

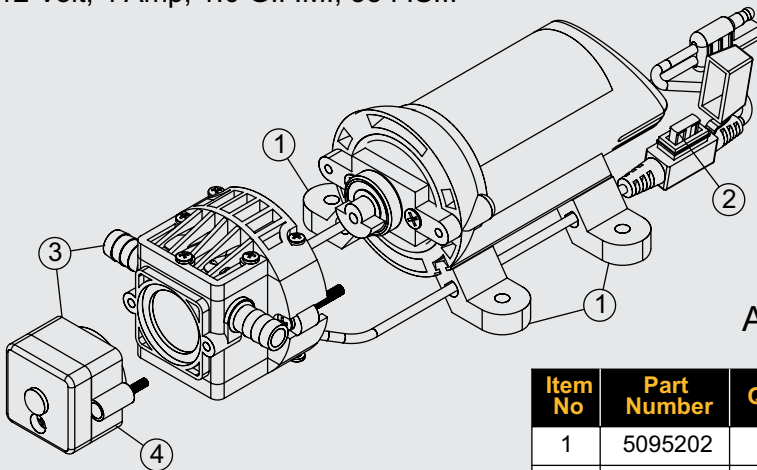

Available Replacement Parts

Item No	Part Number	Qty	Description	Retail Package
1	5095202	1	Mounting Feet (Pkg of 4)	7772088
2	5157204	1	5 Amp 'Mini Blade' Fuse	-
3	5275531	1	Pump Assembly with Pressure Switch	-
4	5157201	1	Pressure Switch w/Diaphragm	7771879

PRO SERIES SPRAYERS
UTV SPRAYERS
SPOT SPRAYERS
ATV SPRAYERS
TRAILER SPRAYERS
UTILITY & 3PT SPRAYERS
SMID SPRAYERS & BOOMS
PUMPS
SPRAYER ACCESSORIES
DRY MATERIAL SPREADERS
TRAILER CARTS & AERATORS
SPRAYER COMPONENTS
PARTS/ST BREAKDOWNS

HIGH-FLO 12 VOLT PUMPS



2.1 G.P.M.

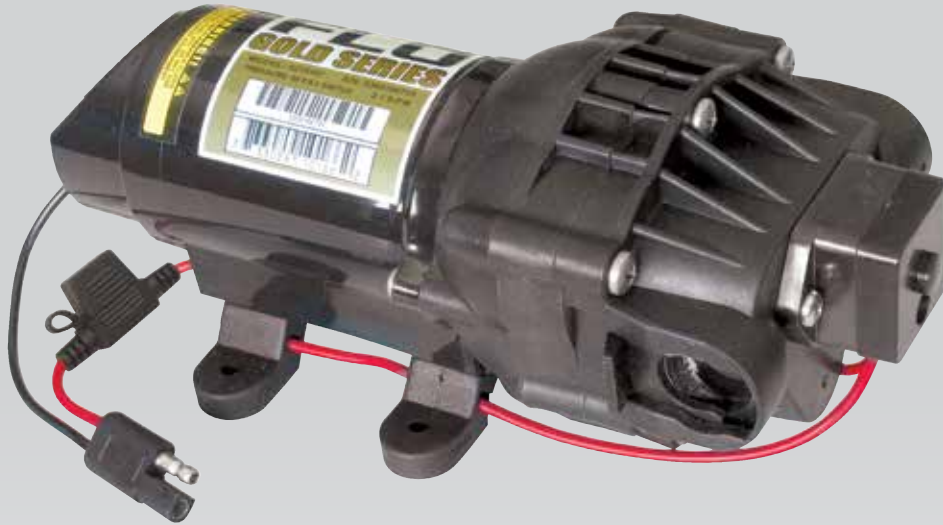

- 12 Volt Diaphragm Pump
- 2.1 G.P.M.
- 60 P.S.I. Max Pressure
- 8 Amp Draw
- Ready For Round-up®
- **DO NOT USE with Flammable or Combustible Liquids**

- DEMAND SWITCH MODELS operate only when liquid flow is required. Pump and motor stop instantly when discharge is closed.
- Diaphragm design eliminates troublesome shaft seal.
- Pump can be run indefinitely without damage.

- Ball bearing drive - assures longer pump life.
- Excellent self-priming capability.
- Santoprene diaphragms and viton valves are standard.
- Maximum temperature of pumped liquid 130°F.
- Permanent magnet motor - long life brushes.

- Fuse Protected
- Built-In cooling fan

Boxed Part #	Individual Part #	Volts	Amps	Demand Switch or Relief Valve	Max Pressure	GPM	UPC Code	List Price
5275087	5277981	12	8.0	Demand Switch	60	2.1	733029101853 (Boxed)	\$ 145.39

Pump Model: 5277981

12 Volt, 8 Amp, 2.1 G.P.M., 60 P.S.I.

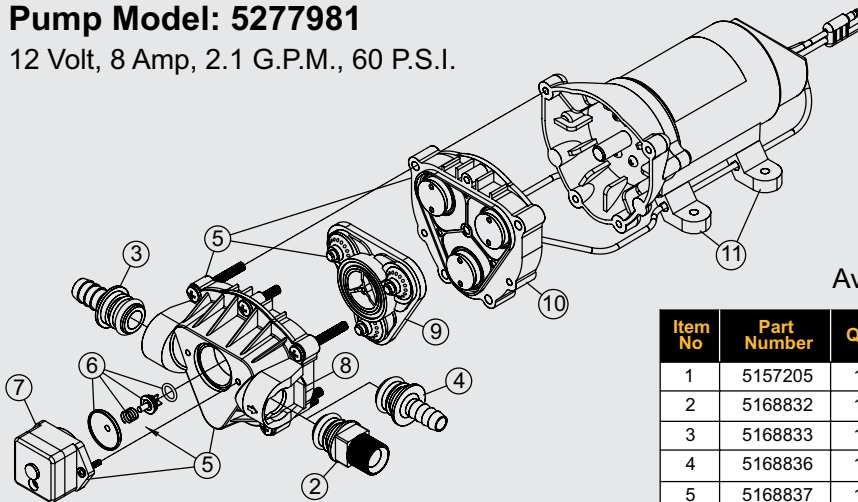

Available Replacement Parts

Item No	Part Number	Qty	Description	Retail Package
1	5157205	1	7.5 Amp 'Mini Blade' Fuse	-
2	5168832	1	Port Kit Fitting, 1/2" MNPT	7771824
3	5168833	1	Port Kit Fitting, 1/2" Hose Barb	
4	5168836	1	Port Kit Fitting, 3/8" Hose Barb	
5	5168837	1	Upper Housing Assembly	-
6	5168839	1	Plunger Kit	-
7	5157202	1	Pressure Switch Assembly	7771880
8	20408-000	1	Pkg. (2) Clips (Port Fitting)	7771830
9	5168820	1	Check Valve Kit (w/O-Ring)	7771833
10	5168838	1	Diaphragm/Piston/Cam/Bearing Kit	-
11	5095202	1	Mounting Feet (Pkg of 4)	7772088

12 VOLT PUMPS



2.1 G.P.M. BYPASS



- Internal Bypass Pump; 2.1 G.P.M.
- Pumps Until Power Is Shut Off
- 60 P.S.I. Max Pressure
- 8 Amp Draw
- Ready For Round-Up®
- **DO NOT USE with Flammable or Combustible Liquids**

- RELIEF VALVE MODELS have pressure controlled by an internal relief valve, and run continuously unless electric current is turned off.
- Diaphragm design eliminates troublesome shaft seal.
- Pump can be run indefinitely without damage.
- Ball bearing drive - assures longer pump life.
- Excellent self-priming capability.
- Santoprene diaphragms and viton valves are standard.
- Maximum temperature of pumped liquid 130°F.
- Permanent magnet motor - long life brushes.
- Fuse Protected
- Built-In cooling fan

Boxed Part #	Individual Part #	Volts	Amps	Demand Switch or Relief Valve	Max Pressure	GPM	UPC Code	List Price
5275814	5277995	12	8.0	Relief Valve	60	2.1	733029102560 (Boxed)	\$ 148.28

Pump Model: 5277995

12 Volt, 8 Amp, 2.1 G.P.M., Bypass, 60 P.S.I.

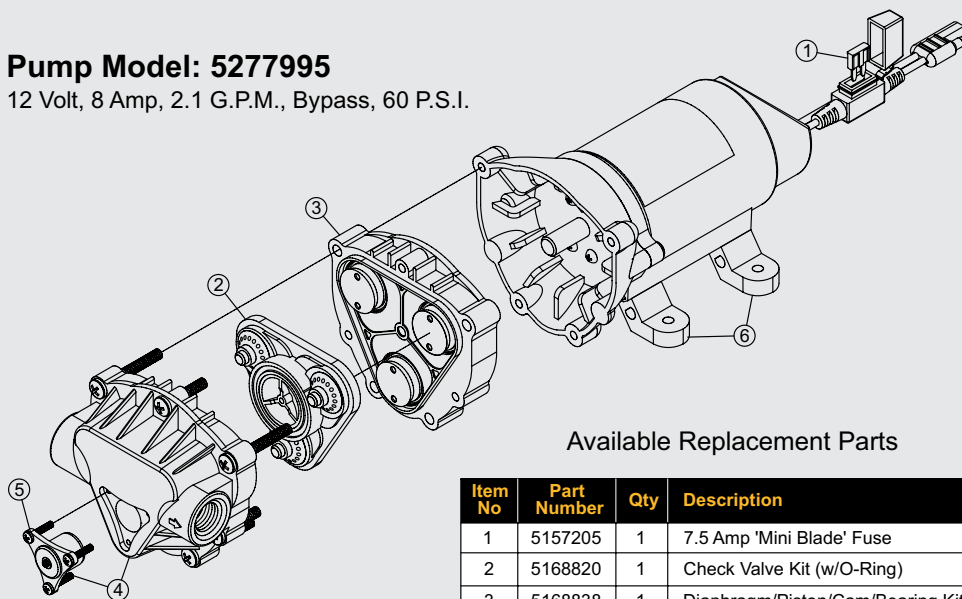

Available Replacement Parts

Item No	Part Number	Qty	Description	Retail Package
1	5157205	1	7.5 Amp 'Mini Blade' Fuse	-
2	5168820	1	Check Valve Kit (w/O-Ring)	7771833
3	5168838	1	Diaphragm/Piston/Cam/Bearing Kit	-
4	5277233	1	Head/Bypass Assembly (2.1 gpm)	-
5	5277232	1	Bypass Assembly (2.1 gpm)	-
6	5095202	1	Mounting Feet (Pkg of 4)	7772088

PRO SERIES SPRAYERS
UTV SPRAYERS
SPOT SPRAYERS
ATV SPRAYERS
TRAILER SPRAYERS
UTILITY & 3PT SPRAYERS
SMID SPRAYERS & BOOMS
PUMPS
SPRAYER ACCESSORIES
DRY MATERIAL SPREADERS
TRAILER CARTS & AERATORS
SPRAYER COMPONENTS
PARTS/UST BREAKDOWNS

12 VOLT PUMPS



3.8 G.P.M.



- 12 Volt Diaphragm Pump
- 3.8 G.P.M.
- 45 P.S.I. Max Pressure
- 11 Amp Draw
- Ready For Round-up®
- **DO NOT USE with Flammable or Combustible Liquids**

- DEMAND SWITCH MODELS operate only when liquid flow is required. Pump and motor stop instantly when discharge is closed.
- Diaphragm design eliminates troublesome shaft seal.
- Pump can be run indefinitely without damage.

- Ball bearing drive - assures longer pump life.
- Excellent self-priming capability.
- Santoprene diaphragms and viton valves are standard.
- Maximum temperature of pumped liquid 130°F.
- Permanent magnet motor - long life brushes.

- Fuse Protected
- Built-In cooling fan

Boxed Part #	Individual Part #	Volts	Amps	Demand Switch or Relief Valve	Max Pressure	GPM	UPC Code	List Price
5275088	5277982	12	11.0	Demand Switch	45	3.8	733029101860 (Boxed)	\$ 189.29

Pump Model: 5277982

12 Volt, 11 Amp, 3.8 G.P.M., 45 P.S.I.

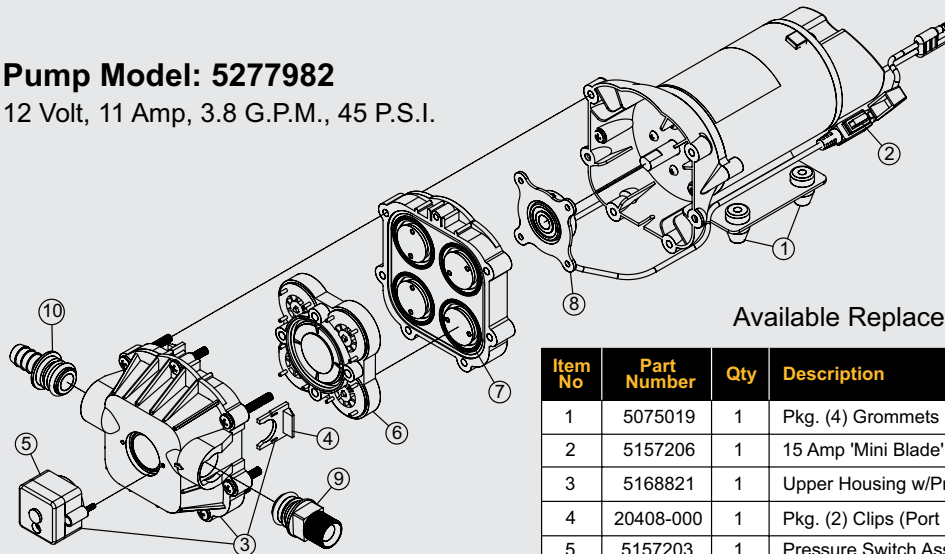

Available Replacement Parts

Item No	Part Number	Qty	Description	Retail Package
1	5075019	1	Pkg. (4) Grommets	-
2	5157206	1	15 Amp 'Mini Blade' Fuse	-
3	5168821	1	Upper Housing w/Pressure Switch	-
4	20408-000	1	Pkg. (2) Clips (Port Fitting)	7771830
5	5157203	1	Pressure Switch Assembly	7771881
6	5168824	1	Check Valve w/O-Ring	7771878
7	5168826	1	Diaphragm Kit w/Pistons & (4) Screws	-
8	5168828	1	Cam/Bearing Kit, w/Set Screw	-
9	5168832	1	Port Kit Fitting, 1/2" MNPT	7771831
10	5168833	1	Port Kit Fitting, 1/2" Hose Barb	

12 VOLT PUMPS

SHURFLO® 8009-598-236



- 12 Volt Diaphragm Pump
- 2.2 G.P.M.
- 60 PSI
- Viton Valves
- Santoprene Diaphragm
- Two Pin Connector 6" Long
- 3/8"-NPT Female Threads
- **DO NOT USE With Flammable Or Combustible Liquids**

Boxed Part #	Individual Part #	Volts	Amps	Demand Switch or Relief Valve	Max Pressure	GPM	UPC Code	List Price
5281323	5151076	12	8	Demand	60 PSI	2.2	733029117588	Call For Pricing

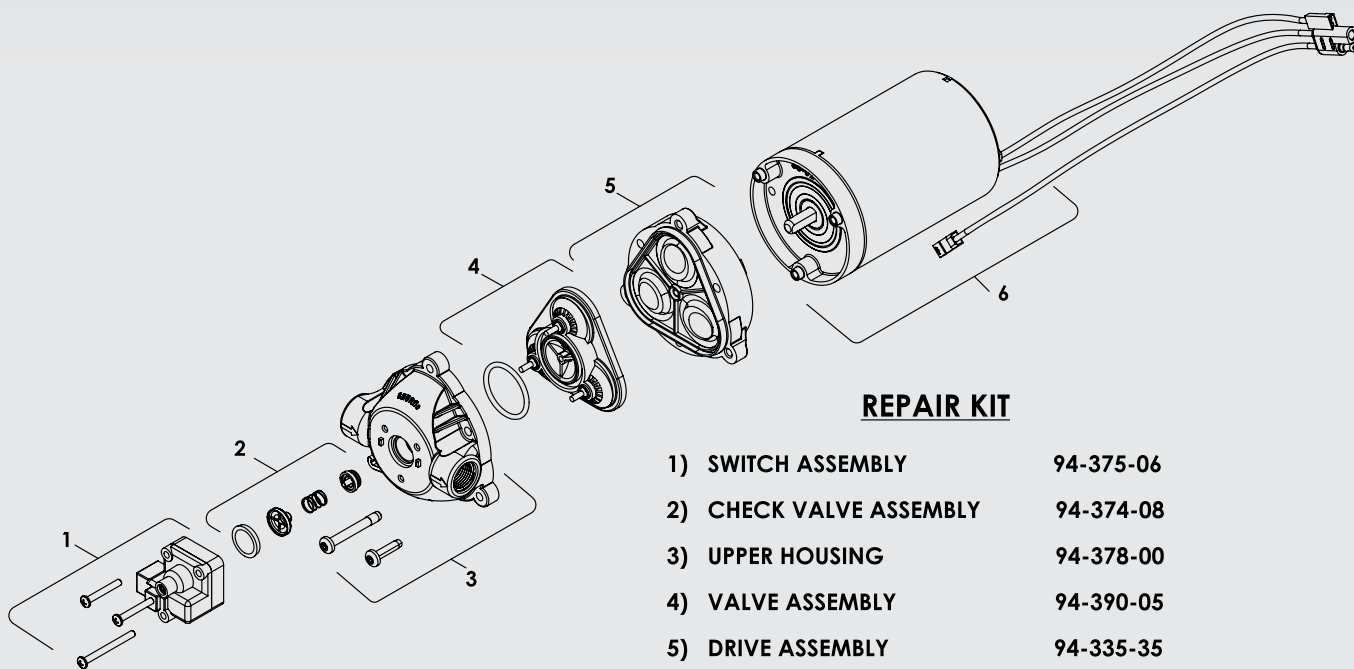

REPAIR KIT

- | | |
|-------------------------|--------------|
| 1) SWITCH ASSEMBLY | 94-375-06 |
| 2) CHECK VALVE ASSEMBLY | 94-374-08 |
| 3) UPPER HOUSING | 94-378-00 |
| 4) VALVE ASSEMBLY | 94-390-05 |
| 5) DRIVE ASSEMBLY | 94-335-35 |
| 6) MOTOR | 94-11-111-04 |

12 VOLT DEMAND DIAPHRAGM PUMP

SHURFLO® 5059-1310/1311



* National Pipe Straight Mechanical

- 12 Volt Diaphragm Pump
- 5.3 G.P.M. (Max)
- 60 P.S.I. (Max)
- 17 Amp Draw (Max)
- Viton Valves
- Santoprene Diaphragm
- Ports
- 1310 - 1/2" NPTF & 1311 - 1/2" NPSM*
- **DO NOT USE with Flammable or Combustible Liquids**

Model	PSI	GPM	BAR	L /min	Amps
5059-1311-D011	0	5.3	0	20.1	6.5
	10	4.7	.69	17.8	9.0
	20	4.3	1.38	16.3	11.8
5059-1310-D011	30	4.1	2.07	15.5	12.4
	40	3.8	2.75	14.4	14.0
	50	3.6	3.45	13.6	15.4
	60	3.4	4.14	12.9	17.0

Boxed Part #	Individual Part #	Volts	Amps	Demand Switch or Relief Valve	Max Pressure	GPM	UPC Code	List Price
5059-1310-D012	5059-1310-D011	12	17	Demand (Pressure Switch)	60	5.3		Call For Pricing
5059-1311-D012	5059-1311-D011	12	17	Constant Flow (Internal ByPass)	60	5.3		Call For Pricing

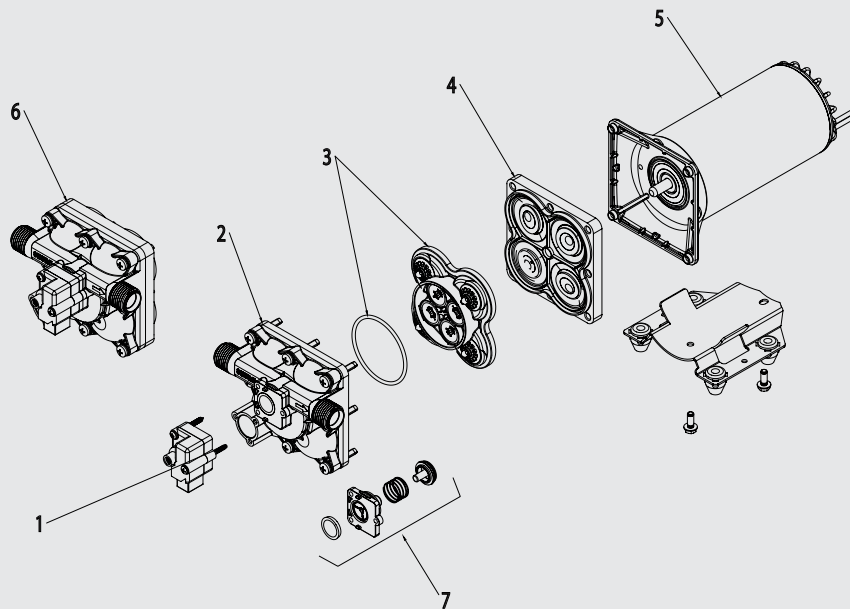

Switched Configuration

Model	1 Switch Only	2 Upper Housing	3 Valve Assembly	4 Drive Assembly	5 Motor	6 Pump Head	7 Check Valve
5059-1310-xxxx	94-910-02	94-910-11	94-910-05	94-910-04	94-71-000-17	94-910-10	94-910-03
5059-1311-xxxx	94-910-02	94-910-01	94-910-05	94-910-04	94-71-000-17	94-910-00	94-910-03

PRO SERIES SPRAYERS
UTV SPRAYERS
SPOT SPRAYERS
ATV SPRAYERS
TRAILER SPRAYERS
UTILITY & 3PT SPRAYERS
SKID SPRAYERS & BOOMS
PUMPS
SPRAYER ACCESSORIES
DRY MATERIAL SPREADERS
TRAILER CARTS & AERATORS
SPRAYER COMPONENTS
PARTSLIST BREAKDOWNS

12 VOLT BYPASS DIAPHRAGM PUMP

SHURFLO® 5059-3610/3611



- 12 Volt Diaphragm Pump
- 5.3 G.P.M. (Max)
- 90 P.S.I. (Max)
- 20.9 Amp Draw (Max)
- Viton Valves
- Santoprene Diaphragm
- Ports
- 3610 - 1/2" NPTF & 3611 - 1/2" NPSM*
- **DO NOT USE with Flammable or Combustible Liquids**

* National Pipe Straight Mechanical

Model	PSI	GPM	BAR	L/min	Amps
5059-3611-D011 5059-3610-D011	0	5.3	0	20.1	6.5
	10	4.7	.7	17.8	9.0
	20	4.3	1.4	16.3	10.2
	30	4.1	2.1	15.5	12.0
	40	3.4	2.8	12.9	13.5
	50	2.6	3.4	9.8	15.2
	60	1.8	4.1	6.8	16.9
	70	1.1	4.8	4.2	18.5
	80	0.4	5.5	1.5	20.1
	90	0.0	6.2	0.0	20.9

Boxed Part #	Individual Part #	Volts	Amps	Demand Switch or Relief Valve	Max Pressure	GPM	UPC Code	List Price
5059-3610-D012	5059-3610-D011	12	20.9	Constant Flow (Internal ByPass)	90	5.3		Call For Pricing
5059-3611-D012	5059-3611-D011	12	20.9	Constant Flow (Internal ByPass)	90	5.3		Call For Pricing

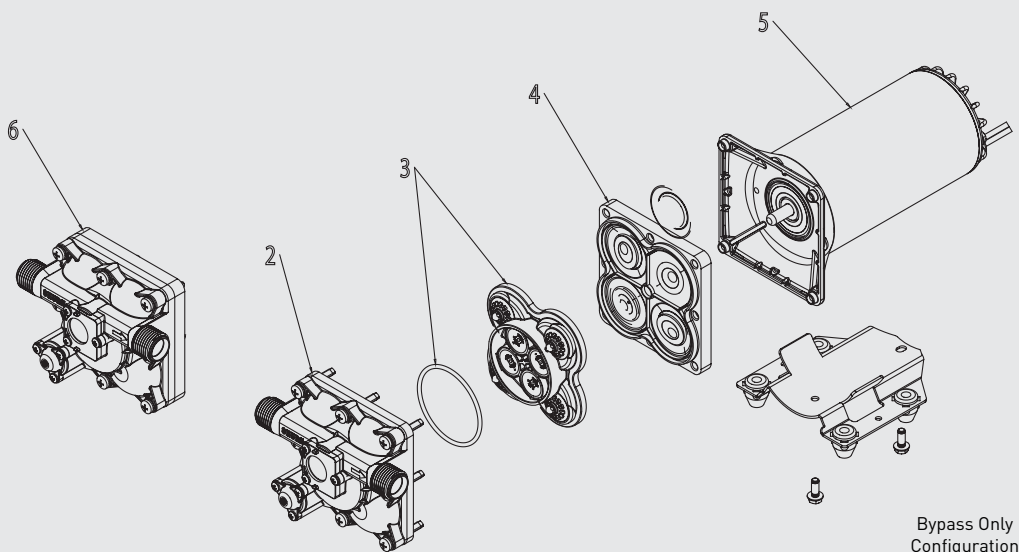

Model	1 Switch Only	2 Upper Housing	3 Valve Assembly	4 Drive Assembly	5 Motor	6 Pump Head	7 Check Valve
5059-3610-xxxx	N/A	94-910-15	94-910-05	94-910-04	94-71-000-17	94-910-13	N/A
5059-3611-xxxx	N/A	94-910-14	94-910-05	94-910-04	94-71-000-17	94-910-12	N/A

PRO SERIES SPRAYERS
UTV SPRAYERS
SPOT SPRAYERS
ATV SPRAYERS
TRAILER SPRAYERS
UTILITY & 3PT SPRAYERS
SKID SPRAYERS & BOOMS
PUMPS
SPRAYER ACCESSORIES
DRY MATERIAL SPREADERS
TRAILER CARTS & AERATORS
SPRAYER COMPONENTS
PARTS/UST BREAKDOWNS

BOOMS & OTHER ACCESSORIES

2 Nozzle Boom

The BK-1 boom assembly is for use on trailer sprayers with pressure controls & pressure gauge. See page 147 for parts list.



Model #	Code #	Description	Wt.	List Price
BK-1	5300954	2 Nozzle boom, w/brackets & feeder hose, 80" Coverage	14	\$ 82.00

5 Nozzle Boom

The BK-5 boom assembly is for use on trailer sprayers with pressure controls & pressure gauge. See page 149 for parts list.



Model #	Code #	Description	Wt.	List Price
BK-5	5300955	5 Nozzle, 3 section break-away boom, w/brackets & feeder hose, 100" Coverage	26	\$ 208.00

7 Nozzle Boom

The BK-70 boom assembly is for use on trailer sprayers with pressure controls & pressure gauge. See page 149 for parts list.



Model #	Code #	Description	Wt.	List Price
BK-70	5301197	7 Nozzle, 3 section break-away boom, 140" Coverage	28	\$ 292.00

On/Off Switch Kit

Can be used on all sprayers with 12 volt electric pumps. Connects between battery and pump wiring and turns sprayer "on" or "off" from the operators seat.

Code #	Description	Wt.	List Price
5278017	96" Wire W/Switch (5 Amp)	1	\$ 9.32
5278114	96" Wire W/Switch (15 Amp)	1	\$ 13.06
5275053	10' Wire Assy W/ Lighter Adapter & Switch	1	\$ 17.49
5273212	5' Extension Cable	1	\$ 6.25
7771827	Standard Handgun W/15' Of Spiral Hose	1	\$ 31.68



Handgun Kit



Model #	Code #	Wt.	List Price
BB-303	5300345	5	\$ 45.00

Standard handgun with 15 ft. of hose, (Optional for LG-1500 and LG-2500).

Handgun Kit



Model #	Code #	Wt.	List Price
BB-304	5300346	6	\$ 56.00

Deluxe handgun w/15 Ft. of hose, (Optional for LG-1500 and LG-2500).

FIMCO 4 FT PLANOGRAM LAYOUT



5277550Each 4 ft planogram comes with **3 of each** of the parts below, \$ 1,945.65
 "Time to reorder" cards, & a 4 ft banner

Part #	Description	Part #	Description	Part #	Description
5173029	TANK & PUMP CLEANER	7771829	PKG.OF (1)5143204 Y-VALVE	7771888	PKG/3/8"POLY SWIVEL HOSE-
7771592	2-STRAINERS	7771830	PKG. OF (2)SLIDE CLIPS	7771913	BLISTERPAK/(2)5168836
7771766	PKG OF (2)25612-6-NYR	7771831	PKG.OF (2) 3.8GPM PUMP	7771938	PKG.OF (1)12V.WIRELESS
7771767	PKG OF (2) TF-VP3 TIPS	7771833	PKG. OF (1)5168820 CHECK	7771950	PACKAGE OF 15 FOOT OF
7771769	PKG OF (2)TP8002VP TIPS	7771873	PKG.OF (1) 5143419	7771952	PKG OF 4 AIXR11002VP
7771770	PKG OF (2)8079-PP-50	7771878	PKG/3.8GPM CHECK VALVE	7771953	PK OF 1 18635-111-406-NYB
7771771	PKG OF ONE 5018331 X26	7771879	PKG/35PSI PRESSURE SWITCH	7771954	PK OF 1 18636-112-406-NYB
7771774	PKG OF ONE ADJUSTABLE TIP	7771880	PKG/60PSI PRESSURE SWITCH	7771955	PK OF 1 18637-113-406-NYB
7771778	PKG OF (1)5167031 GAUGE	7771881	PKG/45PSI PRESSURE SWITCH	7771956	PKG OF 2 25600-1-NYR
7771781	PKG/(1)5274861 NOZZLE,CAP	7771882	PKG OF (2) WAND CLIPS	7771967	MANIFOLD KIT
7771784	PKG. OF (1) 5278114 LEAD	7771883	PKG/5'EXTENSION WIRE	7772014	MULTI-LID FIMCO BOXED
7771786	PKG (1)5275053 LEAD WIRE	7771884	PKG/WETBOOM CENTER NOZZLE	7772086	PKG OF (1) 5167097 GAUGE
7771824	PKG.OF(3)2.1GPM PUMP PORT	7771885	PKG/WETBOOM END NOZZLE	7772087	MANIFOLD REPAIR KIT
7771825	PK.OF(1)DRAINCAP & TETHER	7771886	PKG/QUAD POLY BYPASS TUBE	7772088	FIMCO 4 PK FEET
7771826	PK.OF(1)TANK LID & TETHER	7771887	PKG/TRIPLEX POLY BYPASS		

TEEJET 4 FT PLANOGRAM LAYOUT



5302794 TeeJet parts planogram comes with 4 each..... \$ 9,082.00
of parts shown, plus a 4 foot banner.

FIMCO is a premier distributor of TeeJet products. We can help you custom build a parts planogram for your market.

PRO SERIES
SPRAYERS
UTV
SPRAYERS
SPOT
SPRAYERS
ATV
SPRAYERS
TRAILER
SPRAYERS
UTILITY &
3 FT SPRAYERS
SKID SPRAYERS
& BOOMS
PUMPS
SPRAYER
ACCESSORIES
DRY MATERIAL
SPREADERS
TRAILER CARTS
& AERATORS
SPRAYER
COMPONENTS
PARTSLIST
BREAKDOWNS

PACKAGED & REPLACEMENT PARTS



Part #	OEM Number	Description	UPC Code	Part Size	Part Weight	List Price
7771592	5116242	Small Strainers (2)	733029100863	2-5/8" x 4-3/8"	.01 Lbs	\$ 2.46
7771765	5046052	Nylon Caps - 8027 (2)	733029101341	2-5/8" x 4-3/8"	.05 Lbs	\$ 3.95
7771767	5018327	Tip - TF-VP3 (2)	733029101365	2-5/8" x 4-3/8"	.01 lbs	\$ 7.80
7771769	5018265	Tip - TP8002VP (2)	733029101389	2-5/8" x 4-3/8"	.01 lbs	\$ 4.54
7771770	5116019	Strainer - 50 Mesh-8079-PP-50 (2)	733029101396	2-5/8" x 4-3/8"	.05 Lbs	\$ 5.19



Part #	OEM Number	Description	UPC Code	Part Size	Part Weight	List Price
7771771	5018331	Adjustable Brass Tip For 5273959	733029101402	2-5/8" x 4-3/8"	.10 Lbs	\$ 10.54
7771774	5018330	Adjustable Poly Tip For 5163100	733029101433	2-5/8" x 4-3/8"	.01 Lbs	\$ 9.37
7771778	5167031	Stainless Steel Glycerin Gauge - 100 PSI	733029101495	3" x 5-1/8"	.45 Lbs	\$ 29.23
7771781	5274861	Left/Right Boomless Nozzle Tip, Cap & O-Ring	733029101525	2-5/8" x 4-3/8"	.05 Lbs	\$ 58.55
7771784	5278114	Wire Harness With On/Off Switch	733029101617	3-5/8" x 6-5/8"	.30 Lbs	\$ 14.05



Part #	OEM Number	Description	UPC Code	Part Size	Part Weight	List Price
7771786	5275053	Cigarette Lighter Adapter With On/Off Switch	733029101648	3-5/8" x 6-5/8"	.30 Lbs	\$ 16.38
7771824	5168832, 5168833, 5168836	Port Fittings for 2.1 G.P.M. Pump	733029102379	3-1/2" x 5-1/2"	.10 lbs	\$ 8.77
7771825	5168832, 5168833	Drain Plug & Tether	733029102195	2-5/8" x 4-3/8"	.05 lbs	\$ 5.86
7771826	5058188	Tank Lid & Tether	733029102201	8-3/4" x 9-3/4"	.55 lbs	\$ 16.40
7771829	5143204	Y Valve	733029102270	3" x 5-1/8"	.10 lbs	\$ 9.36

PACKAGED & REPLACEMENT PARTS



Part #	OEM Number	Description	UPC Code	Part Size	Part Weight	List Price
7771830	5003742	Slide Clips for 2.1 & 3.8 G.P.M. Pumps (2)	733029102386	2-5/8" x 4-3/8"	.01 lbs	\$ 8.21
7771831	5168832, 5168833	Port Fittings for 3.8 G.P.M. Pump	733029102393	3-1/2" x 5-1/2"	.05 lbs	\$ 5.83
7771833	5168820	Check Valve for 2.1 G.P.M. Pump	733029102416	3-5/8" x 5-1/2"	.10 lbs	\$ 25.72
7771873	5143419	Single Shut-Off Valve	733029102527	3-1/2" x 5-1/2"	.05 lbs	\$ 8.14
7771878	5168824	Check Valve - 3.8 G.P.M.	733029102645	5-3/8" x 5-1/2"	.15 lbs	\$ 31.61



Part #	OEM Number	Description	UPC Code	Part Size	Part Weight	List Price
7771879	5157201	Check Valve for 2.1 G.P.M. Pump	733029102416	3-5/8" x 5-1/2"	.10 lbs	\$ 32.22
7771880	5157202	60 PSI Pressure Switch For 2.1 G.P.M. Pump	733029102669	2-5/8" x 4-3/8"	.10 lbs	\$ 32.22
7771881	5157203	45 PSI Pressure Switch For 3.8 G.P.M. Pump	733029102676	2-5/8" x 4-3/8"	.10 lbs	\$ 32.22
7771882	5053096, 5117334	Wand Clips	733029102683	2-5/8" x 4-3/8"	.10 lbs	\$ 4.13
7771883	5273212	5 Foot Extension Wire	733029102690	3-5/8" x 6-5/8"	.15 lbs	\$ 7.40



Part #	OEM Number	Description	UPC Code	Part Size	Part Weight	List Price
7771884	5275123	Center Nozzle Wet Boom	733029102706	3-5/8" x 6-5/8"	.25 lbs	\$ 21.06
7771885	5275122	End Nozzle Wet Boom	733029102713	3-5/8" x 6-5/8"	.35 lbs	\$ 76.09
7771887	5100357	Poly Bypass Tube (2.1 G.P.M. Pump)	733029102737	3-3/8" x 9"	.05 lbs	\$ 4.87
7771967	5020201, 5051144, 5075022, 5117168, 5117338, 5143432, 5143435, 5194224, 5302791	Manifold Kit	733029102737	5-1/4" x 11"	.30 lbs	\$ 25.00
7772086	5167097	Back Mount Dry Pressure Gauge	733029111067	3-5/8" x 6-5/8"	.30 lbs	\$ 8.51

PRO SERIES SPRAYERS
 ATV SPRAYERS
 SPOT SPRAYERS
 ATV SPRAYERS
 TRAILER SPRAYERS
 UTILITY & 3PT SPRAYERS
 SKID SPRAYERS & BOOMS
 PUMPS
 SPRAYER ACCESSORIES
 DRY MATERIAL SPREADERS
 TRAILER CARTS & AERATORS
 SPRAYER COMPONENTS
 PARTSLIST BREAKDOWNS

ATV QUICK RELEASE BOOM KITS

PRO SERIES SPRAYERS
UTV SPRAYERS
SPOT SPRAYERS
ATV SPRAYERS
TRAILER SPRAYERS
UTILITY & 3PT SPRAYERS
SKID SPRAYERS & BOOMS
PUMPS
SPRAYER ACCESSORIES
DRY MATERIAL SPREADERS
TRAILER CARTS & AERATORS
SPRAYER COMPONENTS
PARTS/LIST BREAKDOWNS

2-NOZZLE BOOM KIT



80" SPRAY COVERAGE

ATVBK-200-QR



TF-VP3
PREMIUM WIDE ANGLE
INCLUDES NEW ANTI-DRIP STRAINER



5-NOZZLE BOOM KIT



100" SPRAY COVERAGE

ATVBK-500-QR



AIXR
PREMIUM AIR INDUCED
INCLUDES NEW ANTI-DRIP STRAINER



7-NOZZLE BOOM KIT



140" SPRAY COVERAGE

ATVBK-700-QR



AIXR
PREMIUM AIR INDUCED
INCLUDES NEW ANTI-DRIP STRAINER

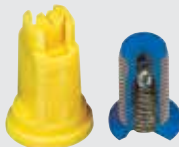

ATV QUICK RELEASE BOOM KITS

7-NOZZLE DELUXE BOOM KIT

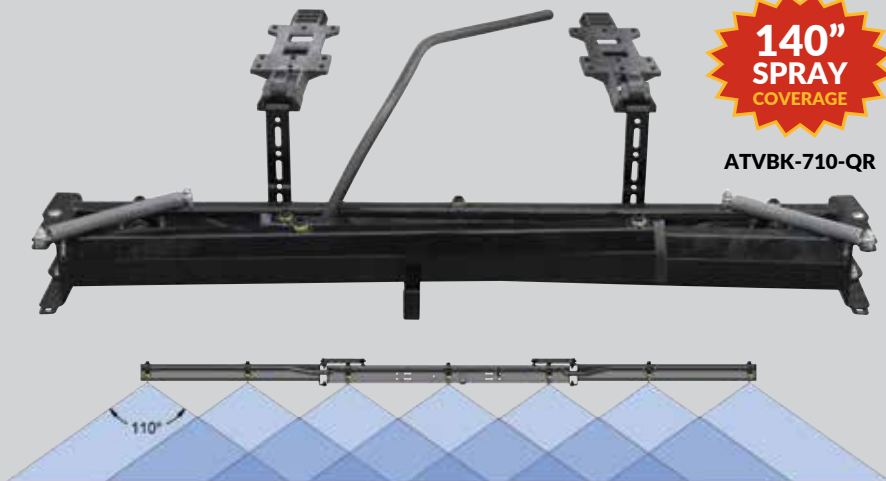

AIXR
PREMIUM AIR INDUCED
INCLUDES CHEMSAVER
DRIP-FREE SHUT OFF



BOOMLESS NOZZLE BOOM KIT

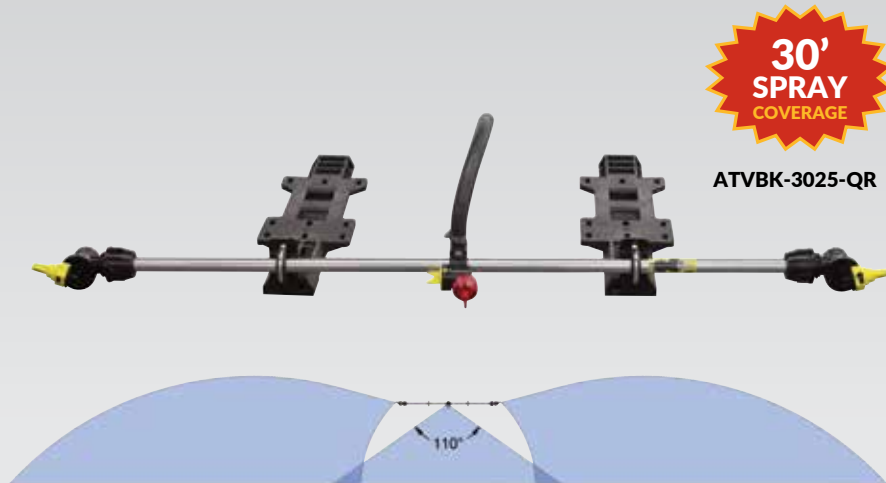

XTENDER END TIPS & CENTER SPRAY TIP
INCLUDES DRIP-FREE
SHUT OFF VALVES



Model #	Code #	Number Of Nozzles	Weight	Carton Size	Shipping Class	Cubic Feet	UPS Able	UPC Code	List Price
ATVBK-200-QR	5302339	2	18	54 x 11 x 6	150	2.0	YES	733029110770	\$ 174.00
- Minimum Pump Requirement - 1.0 G.P.M. DOES NOT INCLUDE TANK AND PUMP.									
ATVBK-500-QR	5302338	5	28	54 x 11 x 6	150	2.0	YES	733029117063	\$303.00
- Minimum Pump Requirement - 2.1 G.P.M. DOES NOT INCLUDE TANK AND PUMP.									
ATVBK-700-QR	5302337	7	29	53 x 11 x 6	150	2.0	YES	733029110756	\$ 315.00
- Minimum Pump Requirement - 2.1 G.P.M. DOES NOT INCLUDE TANK AND PUMP.									
ATVBK-710-QR	5302336	7	40	53 x 11 x 6	150	2.0	YES	733029110749	\$ 459.00
- Minimum Pump Requirement - 3.8 G.P.M. DOES NOT INCLUDE TANK AND PUMP.									
ATVBK-3025-QR	5302334	3	18	54 x 11 x 6	150	2.0	YES	733029110725	\$ 328.00
- Minimum Pump Requirement - 3.8 G.P.M. DOES NOT INCLUDE TANK AND PUMP.									

KITS INCLUDE: Pressure gauge, manifold & hose to convert your spot sprayer into an ATV sprayer.

PRO SERIES SPRAYERS
UTV SPRAYERS
SPOT SPRAYERS
ATV SPRAYERS
TRAILER SPRAYERS
UTILITY & 3PT SPRAYERS
SKID SPRAYERS & BOOMS
PUMPS
SPRAYER ACCESSORIES
DRY MATERIAL SPREADERS
TRAILER CARTS & AERATORS
SPRAYER COMPONENTS
PARTSLIST BREAKDOWNS

DRY MATERIAL SPREADERS

PRO SERIES SPRAYERS
UTV SPRAYERS
SPOT SPRAYERS
ATV SPRAYERS
TRAILER SPRAYERS
UTILITY & 3PT SPRAYERS
SKID SPRAYERS & BOOMS
PUMPS
SPRAYER ACCESSORIES
DRY MATERIAL SPREADERS
TRAILER CARTS & AERATORS
SPRAYER COMPONENTS
PARTS/ST BREAKDOWNS



ATV-DMS-12V	VARIABLE SPEED CONTROL	APPROVED FOR:
	 5' TO 45' SPREAD WIDTH	<ul style="list-style-type: none"> • FERTILIZER • SEED • BAIT • PELLETS • ICE MELTING PELLETS • GRANULAR - INSECTICIDES - FUNGICIDES - HERBICIDES 

ATV-DMS-12V

Model #	Code #	Capacity	Shipping Weight	Carton Size	Shipping Class	UPS Able	UPC Code	List Price
ATV-DMS-12V	5301845	2.2 cu ft	69	29 x 21 x 22	85	81#	733029008633	\$ 584.00
VSC-10	5275918					3#	733029102812	\$ 177.25

VSC-10 Can be purchased separately and works on all 12 volt High-Flo pumps

DRY MATERIAL SPREADERS

MOUNTED ON AN ATV

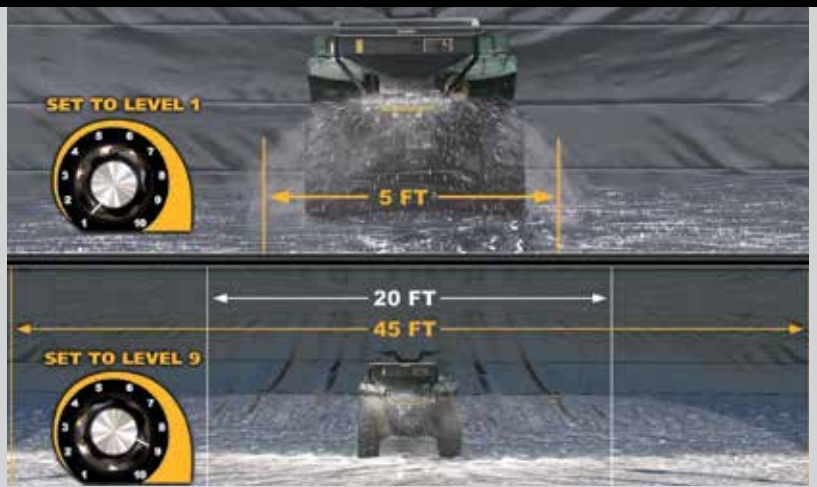
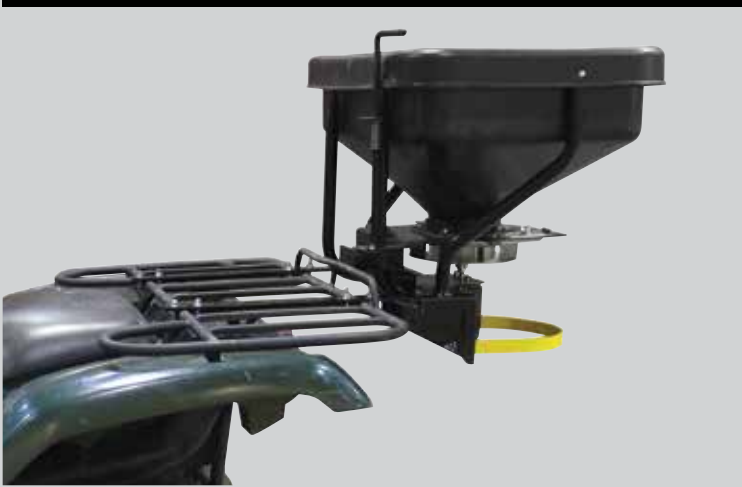

MOUNTED ON A PICKUP



By using the optional receiver hitch mount, the ATV-DMS-12V can easily be attached to a pickup to make de-icing a simple task! And with the dust cover on top, your de-icing material won't get wet or fly out of the hopper.

OPTIONAL DRY MATERIAL ACCESSORIES



Rain Cover
5058193



1-1/4" Hitch
5301902



2" Hitch
5301901

Model #	Code #	Carton Size	Shipping Class	UPS Able	UPC Code	List Price
1-1/4" Receiver Hitch	5301902	25 x 13 x 3	85	20#	733029009081	\$ 108.00
2" Receiver Hitch	5301901	25 x 13 x 3	85	20#	733029009074	\$ 142.00
Rain Cover	5058193			1#	733029104014	\$ 7.34
3 Pack Rain Cover	7771916	25 x 13 x 3		2#	733029107442	\$ 29.27

PRO SERIES SPRAYERS
UTV SPRAYERS
SPOT SPRAYERS
ATV SPRAYERS
TRAILER SPRAYERS
UTILITY & 3PT SPRAYERS
SKID SPRAYERS & BOOMS
PUMPS
SPRAYER ACCESSORIES
DRY MATERIAL SPREADERS
TRAILER CARTS & AERATORS
SPRAYER COMPONENTS
PARTSLIST BREAKDOWNS

DRY MATERIAL SPREADERS



DMS-TR-12V-2.2

VARIABLE SPEED CONTROL

APPROVED FOR:



5' TO 45'
SPREAD WIDTH

- FERTILIZER
- SEED
- BAIT
- PELLETS
- ICE MELTING PELLETS
- GRANULAR
- INSECTICIDES
- FUNGICIDES
- HERBICIDES



DMS-TR-12V-2.2

Model #	Code #	Hopper Size	Shipping Weight	Carton Size	Shipping Class	Cubic Feet	UPS Able	UPC Code	List Price
DMS-TR-12V-2.2	5302028	2.2 Cu Ft.	108	29 x 20 x 26	85	8.8	91#	733029010476	\$ 624.00
VSC-10	5275918						3#	733029102812	\$ 177.25

VSC-10 Can be purchased separately and works on all 12 volt High-Flo pumps

DRY MATERIAL SPREADERS



6-BLADE RADIAL FAN



VARIABLE SPEED CONTROL



5' TO 45'
SPREAD WIDTH

APPROVED FOR:

- FERTILIZER
- SEED
- BAIT
- PELLETS
- ICE MELTING PELLETS
- GRANULAR
- INSECTICIDES
- FUNGICIDES
- HERBICIDES



DMS-TR-12V-5.0

Model #	Code #	Hopper Size	Shipping Weight	Carton Size	Shipping Class	Cubic Feet	UPS Able	UPC Code	List Price
DMS-TR-12V-5.0	5302035	5.0 Cu Ft.	165	40 x 44 x 36	85	36.7	NO	733029010544	\$ 884.00
VSC-10	5275918						3#	733029102812	\$ 177.25

VSC-10 Can be purchased separately and works on all 12 volt High-Flo pumps

DRY MATERIAL SPREADERS

PRO SERIES SPRAYERS
UTV SPRAYERS
SPOT SPRAYERS
ATV SPRAYERS
TRAILER SPRAYERS
UTILITY & 3PT SPRAYERS
SKID SPRAYERS & BOOMS
PUMPS
SPRAYER ACCESSORIES
DRY MATERIAL SPREADERS
TRAILER CARTS & AERATORS
SPRAYER COMPONENTS
PARTS/LIST BREAKDOWNS



DMS-3PT-12V-4.5

VARIABLE SPEED CONTROL

APPROVED FOR:



- FERTILIZER
- SEED
- BAIT
- PELLETS
- ICE MELTING PELLETS
- GRANULAR
- INSECTICIDES
- FUNGICIDES
- HERBICIDES



DMS-3PT-12V-4.5

Model #	Code #	Hopper Size	Shipping Weight	Carton Size	Shipping Class	Cubic Feet	UPS Able	UPC Code	List Price
DMS-3PT-12V-4.5	5302045	4.5 Cu Ft.	125	40 x 26 x 30	85	18	NO	733029010551	\$ 692.00
VSC-10	5275918						3#	733029102812	\$ 177.25

VSC-10 Can be purchased separately and works on all 12 volt High-Flo pumps

POLY & STEEL LAWN ROLLERS



Poly Roller

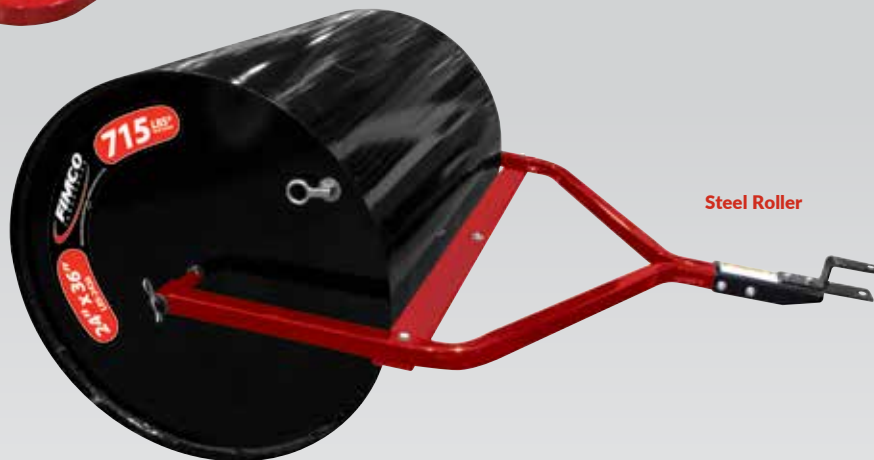

Steel Roller

POLY ROLLERS

- Polyethylene Lawn Roller
- Tow hitch
- Rounded End Caps prevent gouging and will not leave ruts
- Polyethylene drum resist rust and dents
- Lightweight when empty, for easy transportation and storage
- Durable (1") hitch tubes for towing
- Common hitch pin attachment for easy use with any vehicle
- Provides level surface to combat effects of freezing, burrowing animals, and wheel track ruts
- Effective packing of new seeding and soil to root contact for newly laid sod

STEEL ROLLERS

- Steel Lawn Roller
- 14 gauge steel end cap and drums
- Tow Hitch
- Durable (1") hitch tubes for towing
- Common hitch pin attachment for easy use with any vehicle
- Provides level surface to combat effects of freezing, burrowing animals, and wheel track ruts
- Effective packing of new seeding and soil to root contact for newly laid sod

LAWN ROLLERS

Model #	Code #	Material	Roller Size	Weight With Water	Shipping Weight	Carton Size	Shipping Class	UPS Able	UPC Code	List Price
LRP-1824	5301944	Poly	18 x 24	268	42	32 x 20 x 18	85	60#	733029009296	\$ 252.00
LRP-1836	5301945	Poly	18 x 36	390	51	44 x 20 x 18	85	82#	733029009302	\$ 275.00
LRP-1848	5301946	Poly	18 x 48	510	63	57 x 20 x 18	85	106#	733029009319	\$ 296.00
LRP-2436	5301947	Poly	24 x 36	668	76	44 x 25 x 25	85	142#	733029009326	\$ 348.00
LRP-2448	5301948	Poly	24 x 48	878	92	56 x 25 x 25	85	NO	733029009333	\$ 383.00
LRS-2436	5301949	Steel	24 x 36	715	163	44 x 25 x 25	85	NO	733029009340	\$ 543.00
LRS-2448	5301950	Steel	24 x 48	934	189	56 x 25 x 25	85	NO	733029009357	\$ 626.00

42" TINE DE-THATCHER

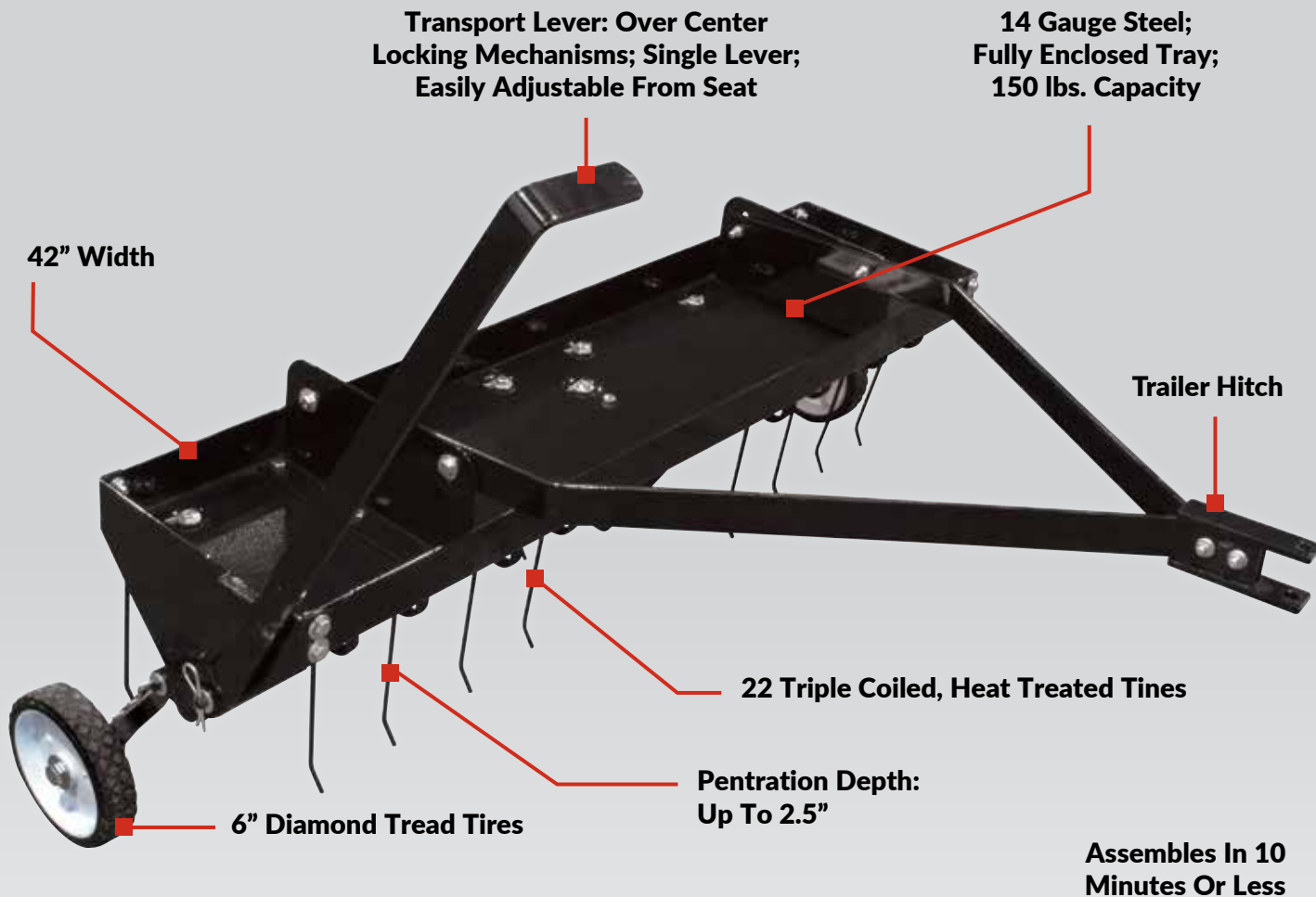

DTH-42



DTH-42

Model #	Code #	Width	Shipping Weight	Carton Size	Shipping Class	Cubic Feet	UPS Able	UPC Code	List Price
DTH-42	5301491	42 Inches	50	50 x 13 x 11	150	4.2	50#	733029004581	\$ 226.00

42" PLUG AERATOR

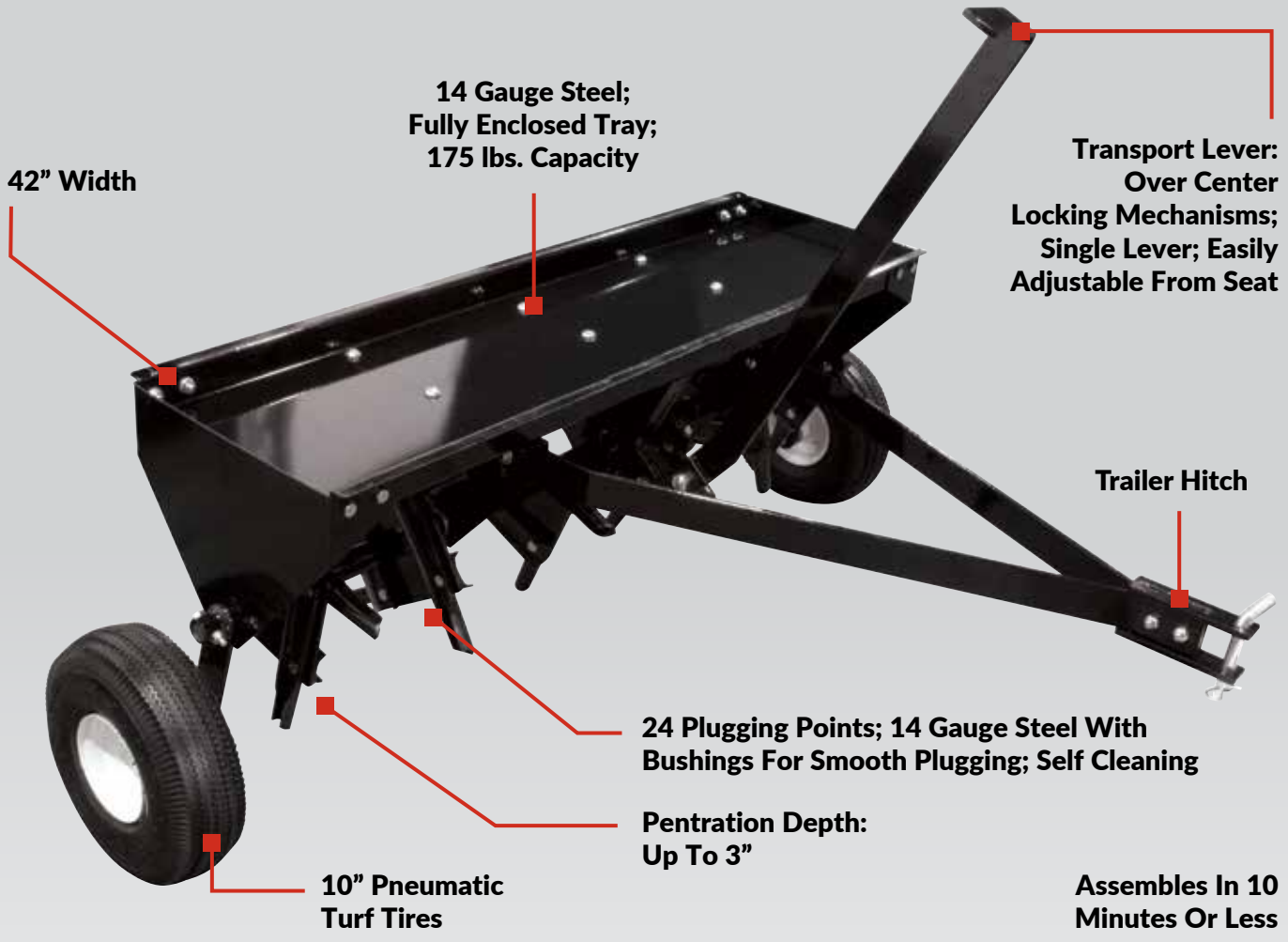

Assembles In 10 Minutes Or Less

PLG-42



PLG-42

Model #	Code #	Width	Shipping Weight	Carton Size	Shipping Class	Cubic Feet	UPS Able	UPC Code	List Price
PLG-42	5301530	42 Inches	85	51 x 18 x 14	150	7.5	78#	733029005182	\$ 369.00

PRO SERIES SPRAYERS
UTV SPRAYERS
SPOT SPRAYERS
ATV SPRAYERS
TRAILER SPRAYERS
UTILITY & 3PT SPRAYERS
SKID SPRAYERS & BOOMS
PUMPS
SPRAYER ACCESSORIES
DRY MATERIAL SPREADERS
TRAILER CARTS & AERATORS
SPRAYER COMPONENTS
PARTSLIST BREAKDOWNS

42" SPIKE AERATOR

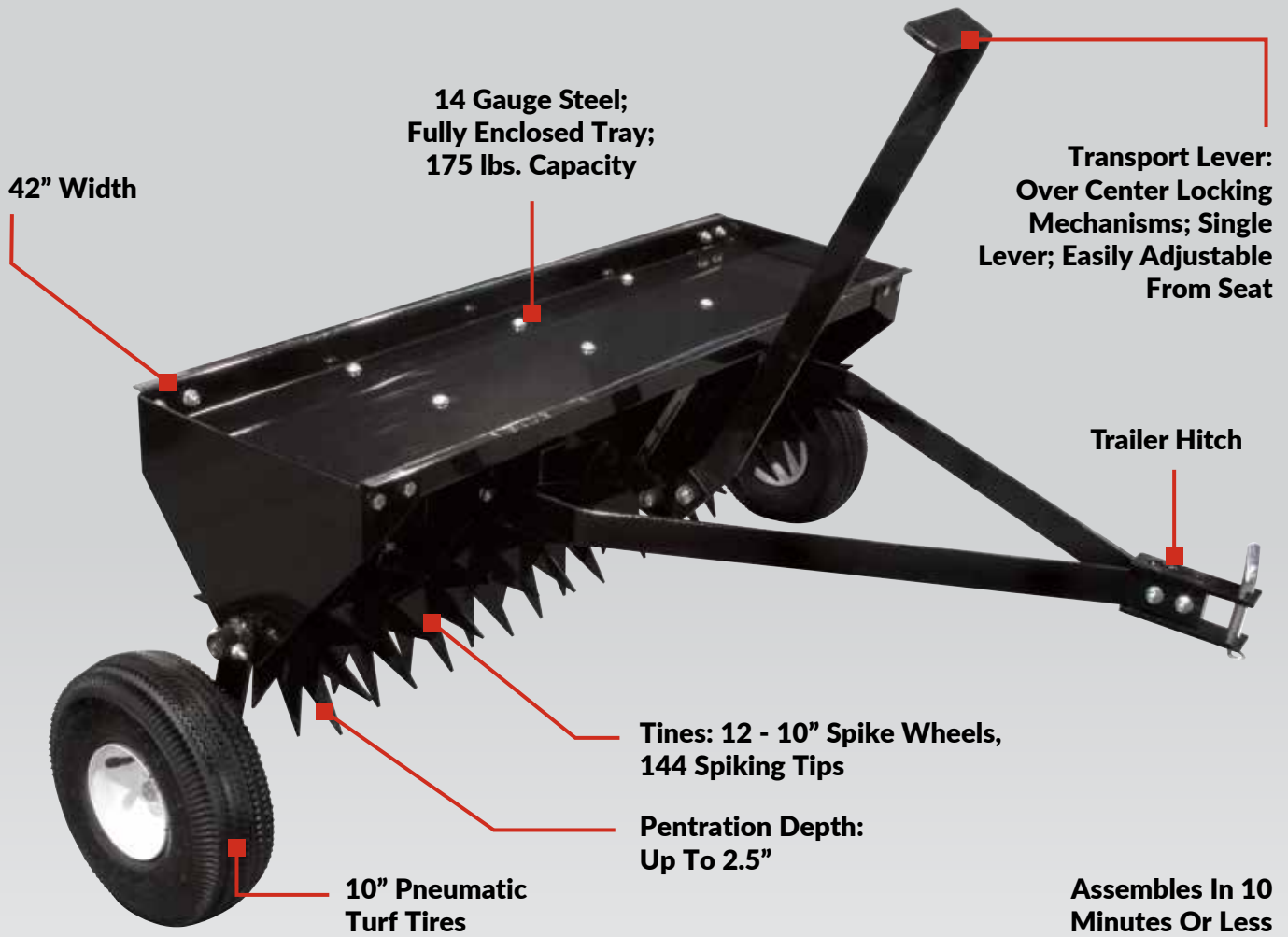

SPK-42



SPK-42

Model #	Code #	Width	Shipping Weight	Carton Size	Shipping Class	Cubic Feet	UPS Able	UPC Code	List Price
SPK-42	5301531	42 Inches	85	51 x 18 x 14	150	7.5	78#	733029005199	\$ 416.00

10 CU. FT. POLY CART

Weight Capacity:
600 lbs.

10 CU. FT.

Convenient
Push/Pull
Handle

Molded-In
Features Let
You Add Bed
Dividers

TC-10-P

Easy
Dump
Release

16" Stud Tread Tire
With Metal Hub

Bed Design:
One Piece Poly

Easy
Dump
Release

TC-10P-EC

Fully Assembled Welded
Pedestal & Under Carriage Frame

TC-10-P

CONVERTIBLE POLY CART

DUMPING ACTION



TC-10-P, TC-10P-EC, & TC-10P-EC-B

Model #	Code #	Box Size	Shipping Weight	Carton Size	Shipping Class	Cubic Feet	UPS Able	UPC Code	List Price
TC-10-P	5301461	10 Cu. Ft.	75	49 x 36 x 14	85	14.5	149#	733029003614	\$ 261.00
TC-10P-EC**	5301841	10 Cu. Ft.	575 Pallet	-	85	-	NO	733029008589	\$ 250.00
TC-10P-EC-B	5302051	10 Cu. Ft.	75	49 x 36 x 14	85	14.5	149#	733029010605	\$ 282.00

**Available only in bulk packaging of 8 carts

15 CU. FT. ATV POLY CART

Bed Design:
One Piece Poly

Weight Capacity:
700 lbs.

15 CU. FT.
Heaping

Bed Dimensions:
59" L x 37" W x 16" H



Easy Step
Dump Release

16" x 6.5" - 8" Tires

3/4" Solid Steel Axle

TC-15-HP

EASY STEP DUMP RELEASE

DUMPING ACTION



TC-15-HP

Model #	Code #	Box Size	Shipping Weight	Carton Size	Shipping Class	Cubic Feet	UPS Able	UPC Code	List Price
TC-15-HP	5302027	15 Cu Ft.	85	48 x 40 x 14-3/4	85	16.5	NO	733029010469	\$ 449.00

10 CU. FT. STEEL TRAILER CART



TC-10-18

Model #	Code #	Box Size	Shipping Weight	Carton Size	Shipping Class	Cubic Feet	UPS Able	UPC Code	List Price
TC-10-18	5301546	10 Cu. Ft.	108	44 x 34 x 14	85	12.2	127#	733029005243	\$ 294.00

PRO SERIES SPRAYERS
UTV SPRAYERS
SPOT SPRAYERS
ATV SPRAYERS
TRAILER SPRAYERS
UTILITY & 3PT SPRAYERS
SKID SPRAYERS & BOOMS
PUMPS
SPRAYER ACCESSORIES
DRY MATERIAL SPREADERS
TRAILER CARTS & AERATORS
SPRAYER COMPONENTS
PARTSLIST BREAKDOWNS

17 CU. FT. STEEL TRAILER CART

Removable Tailgate With Slotted Base For Support

Weight Capacity: 1,500 lbs.

17 CU. FT.

Gauge Of Steel: 16 Gauge Body; 16 Gauge Tailgate



Bed Dimensions: 59" L x 37" W x 16" H

16" x 6.5" - 8" Tires

3/4" Solid Steel Axle

Easy Dump Release

TC-17

EASY DUMP RELEASE

DUMPING ACTION



TC-17

Model #	Code #	Box Size	Shipping Weight	Carton Size	Shipping Class	Cubic Feet	UPS Able	UPC Code	List Price
TC-17	5301397	17 Cu. Ft.	250	61 x 39 x 17	85	23.5	NO	733029003331	\$ 481.00

4 WHEEL STEERABLE 17 CU. FT. TRAILER CART

Removable Tailgate With Slotted Base For Support

Weight Capacity: 2,000 lbs.

17 CU. FT.

Gauge Of Steel: 16 Gauge Body; 16 Gauge Tailgate



4 Wheel Steerable Axle Cart Steerable Front Wheels Makes Moving Around The Farm or Yard Easy.

Bed Dimensions: 59" L x 37" W x 16" H

16" x 6.5" - 8" Tires

3/4" Solid Steel Axle

TC-17-4

REMOVEABLE TAILGATE ACTION



TC-17-4

Model #	Code #	Box Size	Shipping Weight	Carton Size	Shipping Class	Cubic Feet	UPS Able	UPC Code	List Price
TC-17-4	5301398	17 Cu. Ft.	277	61 x 39 x 17	85	23.5	NO	733029003348	\$ 701.00

PRO SERIES SPRAYERS
UTV SPRAYERS
SPOT SPRAYERS
ATV SPRAYERS
TRAILER SPRAYERS
UTILITY & 3PT SPRAYERS
SKID SPRAYERS & BOOMS
PUMPS
SPRAYER ACCESSORIES
DRY MATERIAL SPREADERS
TRAILER CARTS & AERATORS
SPRAYER COMPONENTS
PARTSLIST BREAKDOWNS

FOAM MARKERS & POLYETHYLENE TANKS

FOAM MARKERS

Delivers Maximum Foam With Low Concentrate Usage. Foam Made At End Of Boom Nozzle. No Pumping Of Foam Out To The End Of Boom!

- Maximum foam volume
- 5 gallon tank capacity
- Fits farm sprayer booms up to 80 Feet
- Fast electric side switching with in-cab control
- Adjustable foam control valve
- Environmentally friendly - uses low foam concentrate (2%-3%)
- Electro-pneumatic operated



Model #	Code #	Description	Wt.	List Price
FM-5	5300691	Complete Foam Marker Kit	40	\$ 1,516.00
	5173032	1 Gallon Foam Marker Concentrate	10	\$ 85.58

OVAL SPRAYER TANKS WITH FLAT BOTTOM

Model #	Code #	Description	Weight	List Price
5169262	5169242	15 Gal Oval w/Flat Bottom 34" Long-16" Wide-13" High	8	\$ 69.00
5169264	5169243	25 Gal Oval w/Flat Bottom 39" Long-17.5" Wide-15" High	12	\$ 80.00
5169271	5169245	40 Gal Oval w/Flat Bottom 39.5" Long-24.5" Wide- 20" High	18	\$ 163.94
5169275	5169249	60 Gal Oval w/Flat Bottom & Sump, 26 3/4" Wide x 23" High	24	\$ 214.45

5" Fill Opening - Drain Outlet W/Cap & Tether



VERTICAL SPRAYER TANK

Bundle #	Description	Weight	List Price
5169048	65 Gal Vertical Tank 23" x 42" High (1) 1-1/4" Fitting	25	\$ 212.48

8" Fill Opening - (1) 1-1/4" Side Bottom Fitting



ROUND HORIZONTAL SPRAYER TANKS

Bundle #	Description	Weight	List Price
5169058	25 Gal Round Tank 22-1/2" x 21" w/ (2) 1/2" Fittings.	14	\$ 178.94
5169059	55 Gal Round Tank 22-1/2" x 38"	23	\$ 198.21
5169247	55 Gal Round Tank 22-1/2" x 38" Leg Tank	23	\$ 229.40
*5169003	110 Gal Round Tank 30" x 41"	40	\$ 326.58
*5169020	150 Gal Round Tank 32" x 46"	50	\$ 394.62
*5169004	200 Gal Round Tank 38" x 47"	64	\$ 477.72
*5169056	200 Gal Round Tank 32" x 62"	64	\$ 477.72
*5169002	300 Gal Round Tank 38" x 68"	88	\$ 614.63
*5169029	400 Gal Round Tank 42" x 74"	101	\$ 854.11
*5169030	500 Gal Round Tank 48" x 74"	122	\$ 966.34

5" Fill Opening - (2) 3/4" Bottom Fitting - *8" Fill Opening - (1) 3/4" & (1) 1-1/4" Bottom Fitting



TANKS, SADDLES & STRAPS FOR POLYETHYLENE TANKS



RECTANGULAR SPRAYER TANK

Bundle #	Description	Weight	List Price
5169062	12 Gal Rectangular Tank 18" Long-14" Wide 12" High 3/4" Fitting	9	\$ 139.75

5" Fill Opening - (1) 3/4" Bottom Fitting

ELLIPTICAL HORIZONTAL SPRAYER TANKS



Bundle #	Description	Weight	List Price
5169081*	300 Gal Elliptical Tank 30" High-48" Wide-70" Long	114	\$ 768.64
5169217*	500 Gal Elliptical Tank 36" High-57" Wide-82" Long	163	\$ 1,076.04

* 10" Fill Opening - (1) 3/4" & (1) 1-1/4" Bottom Fitting

NOTE: Price Does Not Include Saddle

SADDLE & STRAPS FOR ROUND HORIZONTAL SPRAYER TANKS



Model #	Bundle #	Description	Weight	List Price
22-55SB	5300326	Saddle for 55 Gallon Tank (22 1/2" Diameter)	34	\$ 147.06
30-110SB	5300860	Saddle for 110 Gallon Tank (30" Diameter)	36	\$ 232.56
32-150SB	5300861	Saddle for 150 Gallon Tank (32" Diameter)	54	\$ 278.16
38-200SB	5300863	Saddle for 200 Gallon Tank (38" Diameter)	57	\$ 304.38
32-200SB	5300862	Saddle for 200 Gallon Tank (32" Diameter)	75	\$ 491.34

SADDLE & STRAPS FOR ROUND HORIZONTAL SPRAYER TANKS (300, 400 & 500 GALLON)



Model #	Bundle #	Description	Weight	List Price
38-300SB	5300864	Saddle for 300 Gallon Tank (38" Diameter)	100	\$ 555.18
42-400SB	5300865	Saddle for 400 Gallon Tank (42" Diameter)	130	\$ 513.00
48-500SB	5300866	Saddle for 500 Gallon Tank (48" Diameter)	138	\$ 538.08

SADDLE & STRAPS FOR ELLIPTICAL HORIZONTAL SPRAYER TANKS (300 & 500 GALLON)

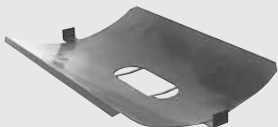

Model #	Bundle #	Description	Weight	List Price
300E-SB	5301509	Saddle for 300 Gallon Elliptical Tank	100	\$ 380.76

PRO SERIES SPRAYERS
UTV SPRAYERS
SPOT SPRAYERS
ATV SPRAYERS
TRAILER SPRAYERS
UTILITY & 3PT SPRAYERS
SKID SPRAYERS & BOOMS
PUMPS
SPRAYER ACCESSORIES
DRY MATERIAL SPREADERS
TRAILER CARTS & AERATORS
SPRAYER COMPONENTS
PARTS LIST BREAKDOWNS

NORWESCO TANKS

VERTICAL STORAGE TANKS

Premium Weight - White in color; Heavy Weight - Blue in color

Gallon Capacity	Diameter	Height/Length	Fill Opening	Drain	Premium Weight Part #	Tank Availability	Heavy Weight Part #	Tank Availability
65 ∞	23"	42"	8"	1 1/4"	45192	A	-	-
105	23"	63"	8"	1 1/4"	40803	A	-	-
150	30"	56"	8"	1 1/4"	41859	A	-	-
165	31"	55"	16"	2" Siphon	40281	A	-	-
200	30"	72"	16"	1 1/4"	41856	A	-	-
210	32"	69"	16"	2" Siphon	47401	A	-	-
250	30"	89"	8"	2" Siphon	41854	A	-	-
300	36"	78"	16"	2" Siphon	40213	A	-	-
305	46"	49"	16"	2" Siphon	40302	C,D,E,F,G,H,L	-	-
500	48"	72"	16"	2" Siphon	40148	A	40150	F,H,L
550	67"	42"	16"	2" Siphon	40023	A	-	-
750	48"	102"	16"	2" Siphon	40606	B,C,D	-	-
1000	64"	79"	16"	2" Siphon	40152	A	40154	B,C,E,F,G,H,L
1100	87"	51"	16"	2" Siphon	40070	A	40081	C,E,F,G,H,L
1350	71"	87"	16"	2" Siphon	40861	H,L	-	-
1500	64"	115"	16"	2" Siphon	40144	B,C,D,E,F,G,L	40146	B,C,F,G,L
1550	87"	65"	16"	2" Siphon	40235	A	40236	A
1700	87"	72"	16"	2" Siphon	40010	B,C,E	40012	B,C,E
2100	102"	69"	16"	2" Siphon	41399	C,E	-	-
2100	87"	87"	16"	2" Siphon	40178	B,C,D,E,F,G,L	40241	B,C,D,E,F,G,L
2500	95"	89"	16"	2" Siphon	40051	A	40052	A
3000	95"	107"	16"	3" Siphon 2" Reducer	40754	A	40755	A
4000	102"	125"	16"	3" Siphon 2" Reducer	40312	B,F,G	-	-
4200	102"	131"	16"	3" Siphon 2" Reducer	41403	C,E	-	-
5000	102"	152"	16"	3" Siphon 2" Reducer	40164	A	40166	A
5800	141"	97"	16"	3" Siphon 2" Reducer	40071	C	-	-
6000	102"	182"	16"	3" Siphon 2" Reducer	40226	B,L	40233	B,L
6100	120"	139"	16"	3" Siphon 2" Reducer	40659	C,D,F,G,H	40661	C,D,F,G,H
6500	120"	150"	16"	3" Siphon 2" Reducer	40224	B,E,L,X	40232	B,E,L,X
7800	120"	176"	16"	3" Siphon 2" Reducer	40663	B,L	40665	B,L
8400	120"	188"	16"	3" Siphon 2" Reducer	42060	L	42062	L
9000	141"	146"	22"	3" Siphon 2" Reducer	43618	B,L	40231	B,L
10,000	141"	160"	22"	3" Siphon 2" Reducer	43128	B,L,X	40353	B,L,X
12,000	141"	192"	22"	3" Stainless Steel/Siphon	43919	L,X	40541	L,X
15,500	141"	244"	22"	3" Siphon 2" Reducer	43941	L	-	-

HORIZONTAL LEG TANKS

Premium Weight - White in color; Heavy Weight - Blue in color

Gallon Capacity	Diameter	Height/Length	Fill Opening	Drain	Premium Weight Part #	Tank Availability	Heavy Weight Part #	Tank Availability
35 ∞	20"	29"	5"	3/4"	45223	A	-	-
55 ∞	23"	33"	5"	3/4"	41873	A	-	-
65 ∞	23"	43"	5"	3/4"	45191	A	-	-
125	32"	41"	8"	2" Siphon	40298	A	-	-
225	38"	49"	8"	2" Siphon	40299	A	-	-
325	38"	68"	16"	2" Siphon	40217	A	-	-
425	49"	60"	16"	2" Siphon	42016	B,C,D,E,F,L	-	-
525	49"	71"	16"	2" Siphon	40181	A	40193	A
725	49"	101"	16"	2" Siphon	40180	C,D,E,F,G	40194	C,D,E,F
1025	49"	139"	16"	2" Siphon	40089	A	40131	A
1325	66"	99"	16"	2" Siphon	41875	B,C,E	41877	B,C,E
1625	63"	134"	16"	2" Siphon	40026	C	40133	C
5025	92"	190"	16"	3" Siphon 2" Reducer	41879	B,C,E,L	41881	B,C,E,L

Note: The 725, 1025 and 1625 gallon tanks REQUIRE FULL LENGTH SUPPORT AND SUPPORT BANDS. ∞May Ship UPS

•Tank Availability Location Key: A=All; B=St. Bonifacius, MN;; C=Lancaster, OH;; D=Griffin, GA; E=Shawnee, OK; F=Tooele, UT; G=Owego, NY; H=Washougal, WA L-Hanford, CA; X=Albertville, AL

NORWESCO TANKS

DRAINABLE LEG TANKS Premium Weight - White in color; Heavy Weight - Blue in color

Gallon Capacity	Diameter	Height/Length	Fill Opening	Drain	Premium Weight Part #	Tank Availability	Heavy Weight Part #	Tank Availability
710 Horizontal	47"	104"	16"	2"	40655	E,C	40657	E,C
1010 Horizontal	47"	140"	16"	2"	40393	B,C,E,L	40395	B,C,E,L
1310 Horizontal	66"	76"/99"	16"	-	41871	B,C,E	41872	B,C,E
1610 Elliptical	69"	63"/140"	16"	-	40806	B,C,E	40808	B,C,E
2610 Elliptical	90"	70"/140"	16"	-	41382	B,C,E	41383	B,C,E
3210 Elliptical	92"	74"/178"	16"	-	40822	B,C,E	40824	B,C,E

Note: Drainable Leg Tanks REQUIRE FULL LENGTH SUPPORT AND SUPPORT BANDS.

ELLIPTICAL TANKS Premium Weight - White in color; Heavy Weight - Blue in color

Gallon Capacity	Diameter	Height/Length	Fill Opening	Drain	Premium Weight Part #	Tank Availability	Heavy Weight Part #	Tank Availability
200	40"	28"/66"	8"	1 1/4"	41252	C,D,E,F,L	-	-
300	48"	32"/70"	16"	1 1/4" x 1 1/4"	40327	B,C,D,F,L	-	-
500	57"	38"/82"	16"	1 1/4" x 1 1/4"	40328	B,C,D,F,L	-	-
750	69"	44"/88"	16"	2"	40329	B,C	-	-
1000	78"	51"/90"	16"	2"	40330	B,C,D	-	-
1600	78"	49"/138"	16"	2"	47111	B,C	-	-
1035 Leg	79"	53"/89"	16"	2" Siphon	40191	B,C,F	-	-
1235 Leg	65"	52"/128"	16"	2" Siphon	40239	B,C	-	-
1635 Leg	71"	57"/142"	16"	2" Siphon	40387	B,C,D,E,F,L	40388	B,C,D,E,F,L
2035 Leg	84"	55"/142"	16"	2" Siphon	40618	B,C,D,E,F	40623	B,C,D,E,F
2635 Leg	90"	71"/140"	16"	3" Siphon 2" Reducer	40547	B,C,D,E,F,L	40283	B,C,D,E,F,L
3135 Leg	88"	76"/151"	16"	3" Siphon 2" Reducer	40686	B,C,D,E,F,L	40688	B,C,D,E,F,L
4035 Leg	92"	77"/192"	16" Hinged	3" Siphon 2" Reducer	41267	B,C,E,L	41269	B,C,E,L

Note: Elliptical Leg Tanks REQUIRE FULL LENGTH SUPPORT AND SUPPORT BANDS.

CONE BOTTOM TANKS Premium Weight - White in color; Heavy Weight - Blue in color

Gallon Capacity	Diameter	Height/Length	Fill Opening	Drain	Premium Weight Part #	Tank Availability	Heavy Weight Part #	Tank Availability
175 w/Stand*	42"	49"/10***	16"	2"	60113	B,C,D,E,F,L	-	-
300 w/Stand*	48"	60"/9***	16"	2"	62343	B,C,D,E,F,L	-	-
310 w/Stand*	42"	71"/10***	16"	2"	62441	B,C,D,E,F,L	-	-
500 w/Stand*	48"	85"/9***	16"	2"	40289	B,C,D,E,F,L	-	-
750	72"	55"	16"	2"	40811	B	-	-
750 w/Stand*	72"	65"/10***	16"	2"	40809	B	-	-
1050	72"	74"	16"	2"	40356	B,C,D,E,F,L	-	-
1050 w/Stand*	72"	85"/11***	16"	2"	40359	B,C,D,E,F,L	-	-
1600	88"	83"	16"	2"	40817	B,C,D,E,F,L	40819	B,C,D,E,F
1600 w/Stand*	88"	94"/11***	16"	2"	40813	B,C,D,E,F,L	40815	B,C,D,E,F
1650	95"	77"	16"	2"	40082	B,C	40127	B,C
1650 w/Stand*	95"	87"/10***	16"	2"	40670	B,C	40676	B,C
2500	95"	104"	16"	2"	40066	B,C,D,F,L	40129	B,C,D,F
2500 w/Stand*	95"	114"/10***	16"	2"	40672	B,C,D,F,L	40674	B,C,D,F
3000	95"	121"	16"	2"	40170	B	40172	B
3000 w/Stand*	95"	131"/10***	16"	2"	40797	B	40799	B
3000-15° Slope	91"	119"	16"	3" Siphon 2" Reducer	45141	E	-	-
5500	118"	146"	16"	3" Siphon 2" Reducer	40549	B,C,E	40316	B,C,E
6000	102"	195"	16"	3" Siphon 2" Reducer	40931	B,C,E,L	40933	B,C,E,L
7500	141"	149"	16"	3" Siphon 2" Reducer	40551	B,C,E	40409	B,C,E

*Polyethylene Stand **Distance from bottom of cone to ground

PICKUP TRUCK TANKS Tanks are white in color

Gallon Capacity	Top Width Or Diameter	Bottom Width Or Diameter	Overall Height	Fill Opening	Drain	Premium Weight Part #	Tank Availability
210	60"/51"	48"/39"	28"	8"	2" Siphon	40300	A
325	62"	49"	32"	8"	2" Siphon	40160	A
425	65"	49"	37"	8"	2" Siphon	40102	A

•Tank Availability Location Key: A=All; B=St. Bonifacius, MN.; C=Lancaster, OH.; D=Griffin, GA; E=Shawnee, OK; F=Tooele, UT; G=Owego, NY; H=Washougal, WA; L=Hanford, CA

PRO SERIES SPRAYERS
UTV SPRAYERS
SPOT SPRAYERS
ATV SPRAYERS
TRAILER SPRAYERS
UTILITY & 3PT SPRAYERS
SKID SPRAYERS & BOOMS
PUMPS
SPRAYER ACCESSORIES
DRY MATERIAL SPREADERS
TRAILER CARTS & AERATORS
SPRAYER COMPONENTS
PARTS LIST BREAKDOWNS

NORWESCO TANKS

APPLICATOR TANKS Tanks are white in color

Gallon Capacity	Diameter	Height/Length	Fill Opening	Drain	Premium Weight Part #	Tank Availability
12 ∞	A	14" w	12"/18"	L	60521	C,D,E,F,L
20 ∞	F,L	15"	31"	L	61737	B,C,D,F,L
30 ∞	A	23"	21"	L	41799	B,C,D,F,L
55 ∞	A	23"	34"	L	45193	B,C
85 ∞	D	23"	52"	L	45105	B,C,D
110	A	30"	41"	K	45053	B,C
150	D	30"	58"	K	40648	B,C,F
150	A	32"	46"	K	45117	B,C
200	A	32"	62"	K	45059	B,C,D,E,F,L
200	A	38"	47"	K	45061	B,C,D,E,F
300	A	38"	68"	K	40135	B,C,D,E,F,L
400	B,C,F	42"	74"	K	40137	B,C,D,E,F,L
500	A	48"	75"	K	40274	B,C,E,L
150 Slim Line	D	28"	40"/50"	K	40777	
200 Slim Line	E,F	24"	46"/61"	K	41305	
200 Slim Line	D	31"	44"/48"	K	40780	

MINI BULK TANKS Tanks are white in color

Gallon Capacity	Diameter	Height/Length	Fill Opening	Drain	Premium Weight Part #	Tank Availability
120	38"	29"	5"	1 1/4"	40318	A
220	42"	42"	5"	1 1/4"	40320	A

SPECIALTY WATER TANKS Tanks are white in color

Gallon Capacity	Diameter	Height/Length	Fill Opening	Drain	Premium Weight Part #	Tank Availability
300 Free Standing	29" w	49"/62"	16"	1 1/4"	41869	B,C,D,E,G,H,L
400 Free Standing	29" w	65"/62"	16"	1 1/4"	41247	B,C,D,E,G,H,L
1000 SPHERE	78" diameter	82" high	16"	2"	41277	L
1250	80" w	35"/132"	16"	2"	40756	B,C
1500	81" w	41"/130"	16"	2"	41392	B,C
2400	90" w	51"/149"	16"	2"	40912	B,C
150	D	30"	58"	K	40648	B,C,F

SPOT SPRAYERS Tanks are white in color

Gallon Capacity	Diameter	Height/Length	Fill Opening	Drain	Premium Weight Part #	Tank Availability
14 ∞	14" W	11"/31"	5"	-	45115	A
25 ∞	18" W	16"/36"	5"	-	62080	A

INDUCTOR TANKS Tanks are white in color

Gallon Capacity	Diameter	Height/Length	Fill Opening	Drain	Premium Weight Part #	Tank Availability
15 ∞	24"	19"	16"	2"	42064	A
15 ∞	19"	23"	8"	2"	60214	A
30 ∞	24"	27"	16"	2"	42065	A
35 ∞	23"	27"	8"	2"	45098	A
60 ∞	31"	31"	16"	2"	62205	A
60 ∞	24"	41"	16"	2"	42066	A

PCO TANKS Tanks are white in color

Gallon Capacity	Width/Height/Length	Fill Opening	Drain	Premium Weight Part #	Tank Availability
30 ∞	19"/22"/25"	5"	-	41254	A
50 ∞	19"/20"/38"	5"	-	40664	A
100	30"/26"/38"	5"	-	40668	A
150	36"/26"/48"	5"	-	40669	A
200	36"/35"/48"	5"	-	41413	A
300	36"/37"/69"	5"	-	41381	A

•Tank Availability Location Key: A=All; B=St. Bonifacius, MN; C=Lancaster, OH; D=Griffin, GA; E=Shawnee, OK; F=Tooele, UT; G=Owego, NY; H=Washougal, WA; L=Hanford, CA

STEEL SUPPORTS

Part #	Size	
60313 ∞	15 Gallon Inductor Stand	See Factory for Prices
65517 ∞	35 Gallon Inductor Stand	See Factory for Prices
62204 ∞	60 Gallon Inductor Stand	See Factory for Prices
63397 ∞	15/30/60 Gallon Inductor Stand for 25" Diagonal Tanks	See Factory for Prices
60520 ∞	35 Horizontal Band	See Factory for Prices
61745 ∞	55 & 65 Horizontal Leg Band	See Factory for Prices
61744 ∞	125 Horizontal Band	See Factory for Prices
60478 ∞	225 & 325 Horizontal Band	See Factory for Prices
60057	425, 525, 725, & 1025 Horizontal Band	See Factory for Prices
60584	710 & 1010 Horizontal Leg Band, Short	See Factory for Prices
60585	1010 Horizontal Leg Band, Long	See Factory for Prices
63282	1310/1325 Drainable Leg Band	See Factory for Prices
60079	1625 Horizontal Leg Band	See Factory for Prices
63284	5025 Horizontal Leg Band	See Factory for Prices
60325	1035 Elliptical Leg Band	See Factory for Prices
60477	1235 Elliptical Leg Band	See Factory for Prices
62434	1610 Elliptical Drainable Leg Band	See Factory for Prices
60586	1635 Elliptical Leg Band	See Factory for Prices
62079	2035 Elliptical Leg Band	See Factory for Prices
63044	2610 Elliptical Drainable Leg Band, Short	See Factory for Prices
63045	2610 Elliptical Drainable Leg Band, Long	See Factory for Prices
63217	2610 Elliptical Drainable Leg Skid	See Factory for Prices
60353	2635 Elliptical Leg Band	See Factory for Prices
62097	3135 Elliptical Leg Band	See Factory for Prices
62347	3210 Elliptical Drainable Leg Band, Short	See Factory for Prices
62348	3210 Elliptical Drainable Leg Band, Long	See Factory for Prices
62906	3210 Elliptical Drainable Leg Skid	See Factory for Prices
62832	4035 Elliptical Leg Band	See Factory for Prices

Part #	Size	
60354	2635/3135 Elliptical Leg Ladder	See Factory for Prices
63047	2610/3210 Elliptical Drainable Leg Ladder	See Factory for Prices
63033	4035 Elliptical Leg Ladder	See Factory for Prices
62301	3135 Adapter Kit for Ladder	See Factory for Prices
60059	Cone Bottom Stand (1650, 2500, 3000)	See Factory for Prices
60359	Top C/B Band (optional for 1650 2500, 3000)	See Factory for Prices
60358	5500 Cone Bottom Stand	See Factory for Prices
62473	6000 Cone Bottom Stand	See Factory for Prices
61860	7500 Cone Bottom Stand	See Factory for Prices
60321 ∞	30 Saddle Assembly	See Factory for Prices
60303 ∞	55 Saddle Assembly	See Factory for Prices
60315 ∞	110 & 150 - 32" Saddle Assembly	See Factory for Prices
63019	200 - 32" Saddle Assembly	See Factory for Prices
63020	200 - 38" Saddle Assembly	See Factory for Prices
63021	300 - 38" Saddle Assembly	See Factory for Prices
63022	400 - 42" Saddle Assembly	See Factory for Prices
63023	500 - 48" Saddle Assembly	See Factory for Prices
63015	200 Elliptical Skid	See Factory for Prices
63016	300 Elliptical Skid	See Factory for Prices
63018	500 Elliptical Skid	See Factory for Prices
60371	750 Elliptical Skid	See Factory for Prices
60372	1000 Elliptical Skid	See Factory for Prices
67428	1600 Elliptical Skid	See Factory for Prices
67456	2550 Elliptical Skid	See Factory for Prices

∞ May ship UPS



BULKHEAD FITTINGS

Part #	Size	Hole Size In Tank	List Price
62834	1/2" Heavy duty double threaded polypropylene fitting	1 7/16"	\$ 6.78
60401	3/4" Double threaded polypropylene fitting	1 7/16"	\$ 5.30
62798	3/4" Heavy duty double threaded polypropylene fitting	1 5/8"	\$ 7.04
60427	1" Double threaded polypropylene fitting	2 1/4"	\$ 6.78
60403	1-1/4" Double threaded polypropylene fitting	2 1/4"	\$ 6.64
60124	1-1/2" Double threaded polypropylene fitting	3"	\$ 10.16
60405	2" Double threaded polypropylene fitting	3"	\$ 9.68
63683	2" Heavy duty polypropylene fitting w/siphon tube	3 1/4"	\$ 16.17
62299	3" Double threaded polypropylene fitting	4 5/8"	\$ 48.62
63279	1-1/2" x 12" long siphon tube		\$ 21.18
63262	2" x 12" long siphon tube		\$ 22.10
63263	3" x 12" long siphon tube		\$ 31.67
62714	4" Siphon tube for 62171		\$ 115.40
60402	3/4" EPDM gasket for 60401		\$ 1.18
60404	1" - 1-1/4" EPDM gasket for 60427 & 60403		\$ 1.64
60406	2" EPDM gasket for 60124, 60405 & 61767		\$ 2.31
60331	3" EPDM gasket for 60339 & 62299		\$ 9.29
62785	4" EPDM gasket for 62171		\$ 30.42
62786	4" Viton gasket for 62171		\$ 154.69
63316	2" MPT vent cap, anti-vortex, without screen		\$ 16.20

NORWESCO TANKS

BOLTED FITTINGS

Part #	Size	List Price
60502	3/4" Polypropylene bolted fitting w/stainless steel & EPDM	\$ 24.34
60355 (2 Required)	Type B Viton gasket for 3/4" & 1"	\$ 20.48
60497 (2 Required)	EPDM gasket for 1-1/2" & 2"	\$ 3.30
62471	3" polypropylene bolted fitting with SS bolts & EPDM gaskets	\$ 51.56
62048 (2 Required)	EPDM gasket for 3"	\$ 11.92

STAINLESS STEEL DOUBLE THREADED BOLTED FITTINGS

Part #	Size	List Price
62948	1" 316 SS double threaded bolted fitting less gasket	\$ 66.27
63205 (1 Required)	EPDM gasket for 1/2", 3/4" & 1"	\$ 10.25
63224 (1 Required)	Type B viton gasket for 1/2", 3/4" & 1"	\$ 42.72
63036	1-1/4" 316 SS double threaded bolted fitting less gasket	\$ 95.15
63206 (1 Required)	EPDM gasket for 1-1/4", 1-1/2" & 2"	\$ 14.29
62848 (1 Required)	Cross-linked polyethylene gasket for 2"	\$ 5.87
63223 (1 Required)	EPDM gasket for 3"	\$ 20.48
63226 (1 Required)	Type B viton gasket for 3"	\$ 170.37
63043 (1 Required)	Cross-linked polyethylene gasket for 3"	\$ 8.22

STAINLESS STEEL SINGLE THREADED BOLTED FITTINGS

Part #	Size	List Price
62847	2" 316 SS single threaded bolted fitting less gasket	\$ 72.19
63206 (1 Required)	EPDM gasket for 2"	\$ 14.29
63225 (1 Required)	Type B viton gasket for 2"	\$ 61.73
62848 (1 Required)	Cross-linked polyethylene gasket for 2"	\$ 5.87
63233	3" 316 SS single threaded bolted fitting, anti-vortex, less gasket	\$ 216.58
63223 (1 Required)	EPD gasket for 3"	\$ 20.48
63226 (1 Required)	Type B viton gasket for 3"	\$ 170.37
63043 (1 Required)	Cross-linked polyethylene gasket for 3"	\$ 8.22

LIDS

Part #	Size	List Price
60038	16" Lid & ring with 6" center lid with air vent	\$ 35.21
60011	16" Lid with 6" center lid with air vent	\$ 31.67
63485	16" Lid and ring with blue snap-in vent	\$ 33.21
60365	16" Lid, ventless	\$ 33.21
62532	16" Hinged lid, with ring & vent	\$ 104.24
63390	16" Hinged lid, ventless,with ring	\$ 104.24
60019	4" Lid with air vent (air vent assembly for 16" lid)	\$ 13.26
60032	8" Lid, ring & air vent	\$ 24.55
60002	8" Lid with air vent	\$ 17.53
60003	8" Ring only	\$ 7.99
63480	8" Lid with blue snap-in vent	\$ 13.56
63484	5" Lid (for tanks manufactured after 2/1/00)	\$ 11.26
63266	2" MPT vent cap with poly screen	\$ 17.53
60366	EPDM gasket for 5" lid, 60322, 62801 or 63264	\$ 6.64
62531	Lanyard (18") for 8" or 16" lid	\$ 1.33
62941	Ethafoam gasket for 16" non-hinged lid	\$ 6.67
60081	Stainless steel screw for 8" and 16" lid	\$ 0.30

HYPRO SPRAYER PUMPS

IMPORTANT NOTE: Use cast iron pumps for general spraying. Use Ni-Resist and XL (Silver series) pumps for liquid fertilizers, soil fumigants and insecticides containing phosphates.
Repair Kits Include Super Rollers, Viton Seals & O-Ring Gasket.

HYPRO®

SERIES 6500 (6 ROLLER) SPRAYER PUMP FITS (540 & 1000 RPM PTO SHAFTS)



Super Roller Equipped
Along with the 7560, the Series 6500 is one of the most widely used pumps on farms today. It's an economical way to handle: water, herbicides, insecticides, emulsions, aromatic solvents, fertilizer, and wettable powder.

9.76 GPM at 540 RPM - 18.2 GPM at 1000 RPM - Max Pressure 300 PSI - Max Speed 1200 RPM - Max Output 21.8 GPM

Code #	MFG Part #	Description	List Price
7771795	3430-0380	Repair Kit	\$ 44.25 \$ 63.50

SERIES 7560 (8 ROLLER) SPRAYER PUMP (540 & 1000 RPM PTO SPEEDS)



Super Roller Equipped The Series 7560 offers a variety of choices in materials for rollers, shaft seals and pump housing. The choice reflects your pumping needs: water, herbicides, insecticides, emulsions, aromatic solvents, fertilizer and wettable powder. Heavy duty construction with 15/16" diameter steel shaft.

12 GPM at 540 RPM - 22.5 GPM at 1000 RPM. Max Pressure 300 PSI - Max Speed 1200 RPM

Code #	MFG Part #	Description	List Price
7771794	3430-0381	Repair Kit	\$ 63.50

SERIES 7700 (7 ROLLER) PUMP (MAX. 800 RPM)



Super Roller Equipped
Plenty of pump for both spraying and agitation — 13 G.P.M. at 50 P.S.I. at 540 rpm PTO speed. Designed for wettable powder herbicides and insecticides. Avoids clogging and helps assure a proper and uniform mix.

Max. Output to 22.1 GPM - Pressure to 200 PSI. Max. Speed 800 RPM - Temperature to 140° F.

Code #	MFG Part #	Description	List Price
7771799	3430-0384	Repair Kit	\$ 87.94 \$ 63.50

SPECIFICATIONS FOR ROLLER PUMPS

Series	MAX GPM	MAX PSI	MAX RPM	SHAFT			Ports Size	Roller Material	Standard Seal	Length	Width	Height
				Height	Diameter Style							
1500	62	150	1000	5"	15/16" Solid		1-1/2" (F)NPT	Super Roller	Buna-N	7-11/16"	8-3/4"	8-1/8"
1700	45	200	1000	3-3/8"	15/16" Solid		1" (F)NPT	Super Roller	Viton	7-23/32"	8-1/4"	6-7/32"
4001	9	150	1800	1-3/4"	5/8" Solid		3/4" (F)NPT	Super Roller	Viton	5-11/32"	4-5/8"	3"
4101	7	150	2600	1-3/4"	5/8" Solid		3/4" (F)NPT	Super Roller	Viton	5-11/32"	4-5/8"	3"
6500	21.8	300	1200	3-5/32"	5/8" Solid		3/4" (F)NPT	Super Roller	Viton	5-11/32"	6"	5-1/2"
7560	22	300	1000	3-3/8"	15/16" Solid		3/4" (F)NPT	Super Roller	Viton	6-13/16"	6-5/8"	5-15/16"
7700	22.1	200	800	3-1/2"	15/16" Solid		3/4" (F)NPT	Super Roller	Viton	6-7/8"	6-5/8"	6"

FIMCO Code #	MFG Part #	Description	List Price
5271706	6500C-A	Cast Iron Pump Less Coupler	\$ 227.00
5271712	6500N-A	Ni-Resist Pump Less Coupler	\$ 510.00
5272446	*6500C-AR	Cast Iron Pump Reverse Rotation	\$ 236.00
5273024	6500XL-A	Silver Series Pump Less Coupler	\$ 704.00
5168226	3420-0023	Base Kit (Fits All 6500 Pumps)	\$ 36.75
5005047	1320-0022	540 RPM Standard Coupler	\$ 29.62
5057145	1321-0012	540 or 1000 RPM Quick Coupler	\$ 55.25
5057031	1321-0006	540 RPM Quick Coupler	\$ 55.25
5005061	1320-0053	1000 RPM Standard Coupler	\$ 40.75
5057033	1321-0008	1000 RPM Quick Coupler	\$ 66.75

*For Use With Gasoline Engine

FIMCO Code #	MFG Part #	Description	List Price
5271077	7560C-A	Cast Iron Pump Less Coupler	\$ 296.00
5271081	7560N-A	Ni-Resist Pump Less Coupler	\$ 578.00
5271509	*7560C-AR-01	Cast Iron Pump Reverse Rotation	\$ 280.00
5273025	7560XL-A	Silver Series Pump Less Coupler	\$ 839.00
5168050	3420-0003	Base Kit (Fits All 7560 Pumps)	\$ 57.75
5005054	1320-0033	540 RPM Standard Coupler	\$ 36.25
5057146	1321-0013	540 or 1000 RPM Quick Coupler	\$ 58.75
5057032	1321-0007	540 RPM Quick Coupler	\$ 59.75
5057034	1321-0009	1000 RPM Quick Coupler	\$ 65.50

*For Use With Gasoline Engine

FIMCO Code #	MFG Part #	Description	List Price
5271085	7700C-A	Cast Iron Pump Less Coupler	\$ 301.00
5271089	7700N-A	Ni-Resist Pump Less Coupler	\$ 578.00
5273026	7700XL-A	Silver Series Pump Less Coupler	\$ 859.00
5005054	1320-0033	540 RPM Standard Coupler	\$ 36.25
5057032	1321-0007	540 RPM Quick Coupler	\$ 59.75

HYPRO SPRAYER PUMPS

SERIES 1700 (5 ROLLER) PUMPS (540 & 1000 RPM PTO SPEEDS)



Super Roller Equipped. The 1700 Series handles a variety of liquids: water, herbicides, insecticides, emulsions, aromatic solvents, fertilizer and wettable powder. Use where moderate flow and pressure is desirable. Output to 45 GPM - Pressure to 200 PSI - Speed to 1000 RPM - Temperature to 140° F

Code #	MFG Part #	Description	List Price
5168816	3430-0383	Repair Kit	\$ 85.75 \$ 63.50

SERIES 1500 (6 ROLLER) PUMPS (540 & 1000 RPM PTO SPEEDS)



Super Roller Equipped. Series 1500 adapts to 1-3/8" or 1-3/4" 1000 RPM PTO shafts as well as 540 RPM. It can be used with a large variety of chemicals. Output to 62 GPM - Pressure to 150 PSI - Speed to 1000 RPM - Temperature to 140° F

Code #	MFG Part #	Description	List Price
5168817	3430-0386	Repair Kit	\$ 84.25

SERIES 4001/4101 (4 ROLLER)

SMALL, DURABLE, LOW-COST PUMPS WITH MANY INDUSTRIAL USES



Super Roller Equipped. Use Series 4001/4101 as a "pressure" pump for spraying, atomizing or blending insecticides, herbicides, fumigants, etc., or as a transfer pump for water, brine, oils, solvents, and many chemicals, or as a circulating pump for lubricants, coolants, and rinsing solutions. Series 4001, for electric motor drive

Code #	MFG Part #	Description	List Price
7771796	3430-0390	Repair Kit	\$ 37.50 \$ 63.50

POWER TAKE OFF COUPLERS



Item	FIMCO Code #	MFG Part #	Description	List Price
1	5057145	1321-0012	Hypro Quick Coupler-Fits 5/8" Shaft (540 or 1000 RPM PTO)	\$ 55.25
1	5057031	1321-0006	Hypro Quick Coupler-Fits 5/8" Shaft (540 RPM PTO)	\$ 55.25
1	5057146	1321-0013	Hypro Quick Coupler-Fits 15/16" Shaft (540 or 1000 RPM PTO)	\$ 58.75
1	5057032	1321-0007	Hypro Quick Coupler-Fits 15/16" Shaft (540 RPM PTO)	\$ 59.75
1	5057033	1321-0008	Hypro Quick Coupler-Fits 5/8" Shaft (1000 RPM PTO)	\$ 66.75
1	5057034	1321-0009	Hypro Quick Coupler-Fits 15/16" Shaft (1000 RPM PTO)	\$ 65.50
2	1323-0076		Forged Steel Coupler-Fits 15/16" Shaft (540/1000 RPM PTO)	\$ 126.00
2	1323-0077		Forged Steel Coupler-Fits 5/8" Shaft (540/1000 RPM PTO)	\$ 150.00
3	5005047	1320-0022	Standard Coupler-Fits 5/8" Shaft (540 RPM PTO) 6 Spline	\$ 29.62
3	5005054	1320-0033	Standard Coupler-Fits 15/16" Shaft (540 RPM PTO)	\$ 36.25
3	5005061	1320-0053	Standard Coupler-Fits 5/8" Shaft (1000 RPM PTO) 21 Spline	\$ 40.75
3	5005058	1320-0038	Standard Coupler-Fits 15/16" Shaft (1000 RPM PTO)	\$ 48.75
3	5005245	1320-0080	Standard Coupler-Fits 15/16" Shaft (1-3/4" 1000 RPM PTO)	\$ 76.25
	5005175	1320-0016	5/8" x 5/8" Adapter Kit	\$ 40.50
	5005240	1320-0015	3/4" x 5/8" Adapter Kit	\$ 41.50
	5026011	3250-0004	Quick Coupler. Balls Only	\$ 1.25
	5005245		1-3/4" Forged Steel PTO Adapter	\$ 76.25
	5005247		1-3/8" Forged Steel PTO Adapter	\$ 52.00
	3430-0540		Torque Arm Kit for Roller Pumps	\$ 66.50

HYPRO®

FIMCO Code #	MFG Part #	Description	List Price
5271710	1700C-A	Cast Iron Pump Less Coupler	\$ 469.00
5271709	1700N-A	Ni-Resist Pump Less Coupler	\$ 960.00
5273027	1700XL-A	Silver Series Pump Less Coupler	\$ 1,284.00
5005054	1320-0033	540 RPM Standard Coupler	\$ 36.25
5057032	1321-0007	540 RPM Quick Coupler	\$ 59.75
5005058	1320-0038	1000 RPM Standard Coupler	\$ 48.75
5057034	1321-0009	1000 RPM Quick Coupler	\$ 65.50
5005245	1320-0080	1000 RPM 1-3/4" Coupler	\$ 76.25

FIMCO Code #	MFG Part #	Description	List Price
5271539	1502C-A	Cast Iron Pump Less Coupler	\$ 720.00
5271451	1502N-A	Ni-Resist Pump Less Coupler	\$ 1,179.00
5273028	1502XL-A	Silver Series Pump Less Coupler	\$ 1,608.00
5005054	1320-0033	540 RPM Standard Coupler	\$ 36.25
5057032	1321-0007	540 RPM Quick Coupler	\$ 59.75
5005058	1320-0038	1000 RPM Standard Coupler	\$ 48.75
5057034	1321-0009	1000 RPM Quick Coupler	\$ 65.50
5005245	1320-0080	1000 RPM 1-3/4" Coupler	\$ 76.25

FIMCO Code #	MFG Part #	Description	List Price
(The Following Pumps Operate up to 1800 RPM)			
5271759	4001C-A	Cast Iron Pump 5/8" Solid Shaft	\$ 227.00
5271760	4001N-A	Ni-Resis Pump 5/8" Solid Shaft	\$ 383.00
5273029	4001XL-A	Silver Series Pump 5/8" Solid Shaft	\$ 560.00
(The Following Pumps Operate up to 2600 RPM)			
5271757	4101C-A	Cast Iron Pump 5/8" Solid Shaft	\$ 209.00
5271758	4101N-A	Ni-Resist Pump 5/8" Solid Shaft	\$ 370.00
5273030	4101XL-A	Silver Series Pump 5/8" Solid Shaft	\$ 546.00
5005175	1320-0016	5/8" Sleeve Coupler Direct To Engine Mount	\$ 40.50
5168259	3420-0025	Base Kit For Gas Engine - 4-3/16" Shaft Centerline	\$ 50.25

CENTRIFUGAL PUMPS

PTO DRIVEN CENTRIFUGAL PUMPS



FIMCO Code #	MFG Part #	Description	Wt	List Price
5271573	PTOC-600-6SP	Cast iron 1-1/4" x 1" straight centrifugal with pulleys and 10 groove belt arranged for direct mounting on 1-3/8 600RPM PTO shaft, 0-70 PSI. Equipped with 6 spline PTO drive shaft. Viton mechanical seal. Fully guarded for operator safety.	45	\$ 1,364.75
5271574	PTOC-600-QC	Cast iron 1 1/4" x 1" straight centrifugal with pulleys and 10 groove belt arranged for direct mounting on 1-3/8" 600RPM PTO shaft 0-70 PSI. Equipped with 6 spline quick coupler PTO drive shaft. Viton mechanical seal. Fully guarded for operator safety.	46	\$ 1,385.35
5271940	PTOC-600-B	Cast iron 1 1/4" x 1" straight centrifugal with pulleys and 10 groove belt. 1" Diameter stub shaft and integral mounting base 600 RPM Tumblerod drive shaft. 0-70 PSI. Equipped with Viton mechanical seal. Fully guarded for operator safety.	42	\$ 1,385.35
5271543	PTOC-1000-21SP	Cast iron 1 1/4" x 1" straight centrifugal with pulleys and 10 groove belt arranged for direct mounting on 1 3/8"1000 RPM PTO shaft. 0-70 PSI. Equipped with 21 spline split PTO drive shaft and split ring locking collar. Viton mechanical seals. Fully guarded for operator safety.	43	\$ 1,390.50
5271822	PTOC-1000-20SP	Cast iron 1 1/4" x 1" straight centrifugal with pulleys and 10 groove belt arranged for mounting on 1 3/4" 1000 RPM PTO shaft. 0-70 PSI. Equipped with split PTO drive shaft and split ring locking collar, Viton mechanical seals. Fully guarded for operator safety.	45	\$ 1,447.15
5273035	PTOC-150-600-6SP	0-100 PSI cast iron straight centrifugal with pulleys and 10 groove belt assembled for mounting on 1-3/8", 600 RPM PTO shaft. Viton mechanical seal. Fully guarded for operator safety.	51	\$ 1,534.70
5273036	PTOC-150-600-6SPQC	0-100 PSI cast iron straight centrifugal with pulleys and 10 groove belt assembled for mounting on 1-3/8", 600 RPM PTO Shaft; equipped with Quick Coupler. Viton mechanical seal. Fully guarded for operator safety	51	\$ 1,555.30
5273037	PTOC-150-1000-21SP	0-100 PSI, cast iron straight centrifugal with pulleys and 10 groove belt assembled for direct mounting on 1-3/8" 1000 RPM PTO Shaft. Equipped with 21 spline PTO shaft and locking collar. Viton Mechanical seal. Fully guarded for operator safety.	48	\$ 1,560.45
5273038	PTOC-150-1000-20SP	0-100 PSI, cast iron straight centrifugal with pulleys and 10 groove belt assembled for mounting on 1-3/4" 1000 RPM PTO shaft. Equipped with 20 spline PTO shaft and locking collar. Viton mechanical seal. Fully guarded for operator safety.	50	\$ 1,617.10

CENTRIFUGAL PUMPS - TRACTOR HYDRAULIC SYSTEM DRIVEN

Cast iron 1 1/4" x 1" frame mounted straight centrifugal pump for tractor hydraulic system applications. Assembled with hydraulic motor equipped with internal check valve to prevent reverse rotation and resulting seal damage. Also equipped with integral needle valve to control input of fluid on open center tractor hydraulic systems and a restrictor orifice to control input of fluid on closed center systems is included with Model FMC-HYD-204. (Models FMC-HYD-210 and FMC-HYD-310 are not equipped with restrictor orifice). To match pump model with tractor hydraulic system capacity, refer to chart below. Models FMC-HYD-204 and FMC-HYD-210 produce 0-100 PSI at maximum 4600 RPM and 60 GPM at open discharge. Model FMC-HYD-310 produces 0-65 PSI at maximum

3950 RPM and 60 GPM at open discharge. For open center systems which require sprayer pump pressures of from 60 to 100 PSI, pump model FMC-HYD-210 should be selected where the tractor system has a minimum of 8 GPM at 500 PSI available at the remote ports.

The New Model No. FMC-150-HYD-206 has 1-1/2" x 1-1/4" ports. Maximum pressure 120 PSI at 5100 RPM at open discharge. 7 GPM hydraulic motor can be used on pressure compensating Closed Center Systems (John Deere Type), Load Sensing Closed Center Systems (Case-IH type), and Open Center Systems Rated 7-16 GPM. Equipped with restrictor Orifice.

++ Indicates which Pumps may be used with which Hydraulic Systems

TRACTOR HYDRAULIC SYSTEM REMOTE OUTLET CAPACITY (GPM)

FIMCO Code #	MFG Part #	Pressure Compensating CLOSED SYSTEM (John Deere Type)	Load Sensing CLOSED SYSTEM (Case-IH Type)	OPEN CENTER	Wt	List Price
5271132	FMC HYD 204	++		++ 4-13 GPM	26	\$ 1,215.40
5271733	FMC HYD 210		++	++ 8-17 GPM	27	\$ 1,215.40
5271734	FMC HYD 310			++ 18-24 GPM	33	\$ 1,246.30
5273039	FMC-150-HYD-206	++	++	++ 7-16 GPM	31	\$ 1,241.15

FRAME MOUNTED CENTRIFUGAL PUMPS - COUNTER-CLOCKWISE ROTATION

FIMCO Code #	MFG Part #	Description	Wt	List Price
5271128	FMC-MIA	Cast iron 1 1/4" x 1" frame mounted straight centrifugal pump for belt drive application. 0-100 PSI at maximum 4600 RPM, 60 GPM at open discharge. Equipped with Viton mechanical seal. Mounting frame machined for idler arm.	18	\$ 576.80
5168201	FMK	Mounting kit for John Deere 1000 RPM front PTO shaft. For use with Ace counterclockwise rotation Models FMC and FMCH, when adapted to John Deere tractor Models 2510, 3010, 4010, 2520, 3020, 4020, and 4520. Includes mounting bracket, belts and splined pulley.	11	\$ 413.55
5271819	FMC-MAG	Cast iron 1 1/4" x 1" frame mounted counterclockwise rotation straight centrifugal pump assembled with 12 volt DC belt driven magnetic clutch. 0-100 PSI at max. 4600 RPM, 60 GPM at open discharge. Equipped with Viton mechanical seal.	22	\$ 1,174.20

PRO SERIES SPRAYERS
UTV SPRAYERS
SPOT SPRAYERS
ATV SPRAYERS
TRAILER SPRAYERS
UTILITY & 3PT SPRAYERS
SKID SPRAYERS & BOOMS
PUMPS
SPRAYER ACCESSORIES
DRY MATERIAL SPREADERS
TRAILER CARTS & AERATORS
SPRAYER COMPONENTS
PARTSLIST BREAKDOWNS

PARTS LIST FOR ACE CENTRIFUGAL PUMPS

TRACTOR PTO DRIVEN

PUMP REPAIR KITS: Includes Belt, VITON Seal, Gaskets & "O" Ring

5168204 (RK-PTOC-600) for Models PTOC-600-6SP, PTOC-600-QC and PTOC-600-B	\$ 117.42
5168205 (RK-PTOC-1000) for Models PTOC-1000-21SP and PTOC-1000-175-20-SP	\$ 118.45



Ref	FIMCO Code #	MFG Part #	Description	Req	List Price
1	5072114	BAC-4	Gasket, 4 Hole	1	\$ 4.12
2	5019087	BAC-5	Idler Torsion Spring	1	\$ 22.66
3	5118118	BAC-6-SS	5/8" Shaft, L. H. Thread, Stainless (Optional)	1	\$ 123.60
4	5072129	BAC-7B	Buna N Seal (Optional)	1	\$ 53.56
4	5072115	BAC-7V	VitonSeal	1	\$ 50.47
4	5072130	40160	"O" Ring For BAC-6 Shaft	1	\$ 1.03
5	5118136	BAC-10-6-SP	1 3/8" 6 Spline PTO (For PTOC-600-10-6SP)	1	\$ 309.00
6	5128001	BAC-10-6SP-QC	1 3/8" 6 Spline PTO (For PTOC-10-QC)	1	\$ 309.00
7	5118137	BAC-10-21SP	1 3/8" 21 Spline PTO (For PTOC-1000-10-21SP)	1	\$ 365.65
8	5118146	BAC-10-175-20SP	1 3/4" 20 Spline PTO (For PTOC-1000-175-20SP)	1	\$ 396.55
9	5118124	BAC-10-S	1" Stub Drive Shaft (For PTOC-600-10B)	1	\$ 303.85
10	5055021	BAC-11	Locking Collar (For BAC-10-21SP Shaft)	1	\$ 118.45
11	5055022	BAC-11-175	Locking Collar (For BAC-10-175 Shaft)	1	\$ 159.65
12	5117178	BAC-11-1	Set Screw (For BAC-11-175 Locking Collar)	1	\$ 1.03
13	5084021	BAC-12	1 1/4" x 1" Volute	1	\$ 247.20
14	5023041	BAC-13	Idler Arm	1	\$ 84.46
15	5070011	BAC-14-MIA	Mounting Frame, Mach. For Idler Arm	1	\$ 267.80
16	5271422	BAC-15	Bearing Housing (For PTO Models)	1	\$ 200.85
	5271425	BAC15-B	Bearing Housing w/base (For PTOC-600-10B)	1	\$ 278.10
17	5159048	BAC-26-Valox	Impeller Valox, L. H. Thread	1	\$ 87.55
17	5159029	BAC-26-CI	Impeller Cast Iron, L. H. Thread (Optional)	1	\$ 195.70
19	5032020	BAC-28-8	Belt, 8 Groove (PTOC-600) (Obsolete)	1	\$ 66.95
19	5032019	BAC-28-8-M	Belt, 8 Groove (PTOC-1000) (Obsolete)	1	\$ 56.65
19	5032022	BAC-28-10	Belt, 10 Groove (PTOC-600-10, & 10B)	1	\$ 58.71
19	5032025	BAC-28-10-M	Belt, 10 Groove (PTOC-1000-10)	1	\$ 59.74
20	5105022	BAC-29-10-1.5	Pully, 10 Groove	1	\$ 80.34
21	5105023	BAC-30-10	Pully, 10 Groove (PTOC-600-10, & 10B)	1	\$ 257.50
21	5105024	BAC-30-10-M	Pully, 10 Groove (PTOC-1000-10)	1	\$ 247.20
21	5105028	BAC-30-175	Pully, 10 Groove (For PTOC-1000-175-20SP)	1	\$ 267.80
22	5031148	BAC-31-1	Ball Bearing, BAC-10 Drive Shaft (792 & up)	2	\$ 49.44
23	5110084	BAC-32	External Snap Ring	2	\$ 0.52
24	5127073	BAC-32-S	Spacer	1	\$ 6.18
25	5110085	BAC-33	Internal Snap Ring	2	\$ 2.06
26	5110086	BAC-34	Internal Snap Ring	2	\$ 5.15
27	5110087	BAC-35	External Snap Ring	1	\$ 1.03
28	5110088	BAC-36	External Snap Ring	1	\$ 2.06
29	5031060	BAC-37	Sealed Ball Bearing	2	\$ 20.60
30	5127155	BAC-38-1	Bearing Spacer, For BAC-10 Drive Shaft (792 & up)	1	\$ 32.96
31	5034099	40950	Hex Head Cap Screw	4	\$ 0.54
32	5117099	BAC-40	Slotted Set Screw	3	\$ 1.03
33	5006099	40960	Jam Nut	3	\$ 0.52
38	5006101	BAC-46	5/8" Spacer	1	\$ 28.84
39	5034084	BAC-47	Cap Screw	1	\$ 8.24
40	5110089	BAC-49	Retainer Ring	1	\$ 0.77
41	5089022	BAC-50	Key	1	\$ 1.55
42	5089023	BAC-51	Key	1	\$ 5.67
43	5049015	BAC-52	1/4" Cold Shut Chain Anchor	1	\$ 4.12
44	5102038	BAC-53	1/8" NPT Pipe Plug	3	\$ 0.52
45	5108028	BAC-54	Slinger	1	\$ 1.55
46	5031066	BAC-55	Idler Bearing And Roller Assembly	1	\$ 59.74
	5271428	BAC-55-A	Idler Arm Assembly	1	\$ 182.05
47	5117100	BAC-57	Set Screw	2	\$ 0.77
	5012009	BAC-58	Zerk Fitting	1	\$ 2.58
48	5034192	41250	Cap Screw	1	\$ 2.06
49	5006035	BAC-63	Self Locking Nut	1	\$ 0.61
50	5117101	41300	Set Screw	2	\$ 0.77
52	5108032	BAC-81-QC	Ball Retainer	1	\$ 31.93
53	5019144	BAC-82-QC	Spring For Quick Coupler	1	\$ 11.33
54	5026022	BAC-83-QC	Ball For Quick Coupler	3	\$ 1.55
	5076003	BGKB	Belt Guard Kit (PTOC-Pumps)	1	\$ 147.81

PUMP MODELS

- PTOC-600-B
- PTOC-600-SP
- PTOC-600-6-SPQC
- PTOC-1000-21-SP
- PTOC-1000-175-20-SP

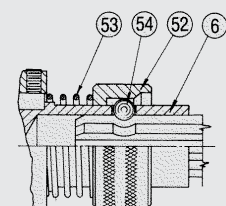
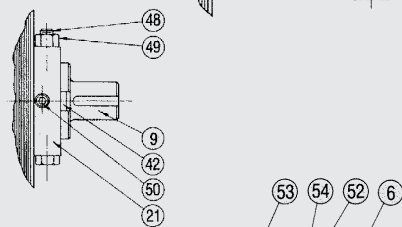
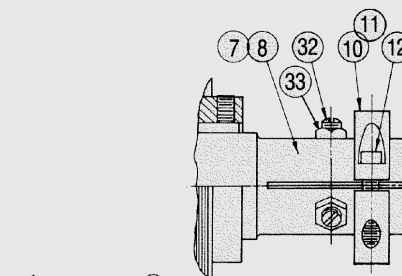
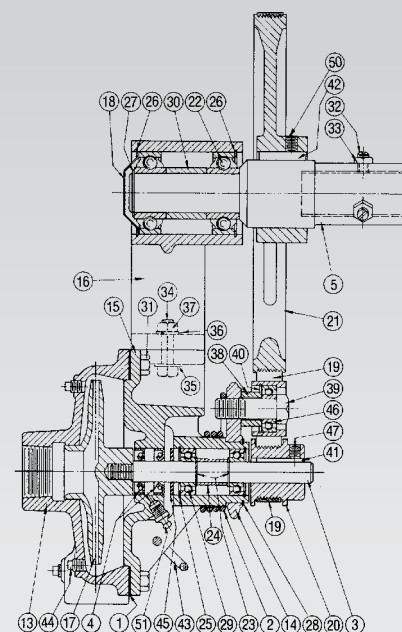

CENTRIFUGAL PUMPS

SERIES 9200 PEDESTAL MODELS



FIMCO Code #	MFG Part #	Max GPM	Max PSI	Max RPM	Description	Shpg Wt.	List Price
5271967	9202C	105	170	6000	Cast Iron - 5/8" Solid Shaft w/Viton Shaft Seal Ports (NPT): 1-1/4" Inlet, 1" Outlet	18 lbs.	\$ 548.00
5271968	9203C	140	170	6000	Cast-Iron - 5/8" Solid Shaft w/Viton Shaft Seal Ports (NPT): 1-1/2" Inlet, 1-1/4" Outlet	19 lbs	\$ 555.00
5272579	9203C-R	140	170	6000	Cast Iron -with 5/8" solid shaft, counter clockwise rotation viton seal, and 1-1/2" x 1-1/4" Ports	17 lbs.	\$ 569.00
5275540	9206C	225	80	4200	Cast iron - with 5/8" solid shaft and Viton Seal, Ports (NPT): 2" Inlet, 1-1/2" Outlet	23 lbs.	\$ 728.00

POLYPROPYLENE CENTRIFUGAL PUMPS (GEAR DRIVEN PTO)



FIMCO Code #	MFG Part #	Max GPM	Max PSI	Max RPM	Description	Shpg Wt.	List Price
5272451	9006P-O	97	83	540	Gears are safely enclosed in the factory lubricated case. It is available in a gear drive for 540 RPM for coupling to standard PTO.	37 lbs.	\$ 1,402.00
5272452	9008P-O	86	67	1000	Gears are safely enclosed in the factory lubricated case. It is available in a gear drive for 1000 RPM for coupling to standard PTO.	37 lbs.	\$ 1,437.00

POLYPROPYLENE CENTRIFUGAL PUMPS (PEDESTAL MOUNTED)



FIMCO Code #	MFG Part #	Max GPM	Max PSI	Max RPM	Description	Shpg Wt.	List Price
5272453	9203P-S	100	80	4200	The pedestal mounted centrifugal pump is designed for direct drive with an electric motor or belt and pulley drive with an electric motor or gas engine. It has a 7/8" keyed 316 Stainless Steel Shaft.	13 lbs.	\$ 688.00

POLYPROPYLENE CENTRIFUGAL PUMPS (HYDRAULIC MOTOR DRIVEN)



FIMCO Code #	MFG Part #	Max GPM	Max PSI	Max RPM	Description	Shpg Wt.	List Price
5273217	9303P-HM1C	110	130	Open / Closed	The hydraulic motor features a fixed displacement internal gear design for smooth operation. A double lip Teflon shaft seal provides excellent reliability even with hydraulic oil back pressure.	20 lbs.	\$ 1,277.00
5272454	9303P-HM3C	110	93	Open	The hardened stainless steel motor/ pump shaft is supported by two needle bearings and a ball bearing for dependable operation through years of use.	21 lbs.	\$ 1,355.00
5272455	9303P-HM4C	82	85	Open / Closed		19 lbs.	\$ 1,277.00

PLEASE CONTACT US FOR ANY SPECIAL ORDER HYPRO PRODUCT REQUESTS

DIAPHRAGM PUMPS & ENGINES

PISTON-DIAPHRAGM PUMPS are ideal for spraying agricultural spray for pest and weed control and liquid fertilizer application. The moving parts are stainless steel hermetically sealed in 100% oil bath and never come in contact with spray liquid. The only moving part of the pump in contact with the spray is the diaphragm which is resistant to most chemicals pumped. Diaphragms and valves can be replaced on the farm without special tools and are

easily accessible from the outside of the pumps. Pumps will run dry and with abrasives, they are positive displacement type pumps and self priming. They are light, and have surge chamber attached. Hose connectors are built on the pumps.

HYPRO®

MEDIUM PRESSURE DIAPHRAGM PUMPS



FIMCO Code #	Max GPM	Max PSI	Max RPM	Description	Shpg Wt.	List Price
9910-D252	6.5	290	650	2 - Diaphragm Pump	12 lbs.	\$ 913.00
9910-D30	9.6	580	550	2 - Diaphragm Pump	23 lbs.	\$ 1,141.00
9910-D403	9.9	580	550	3-Diaphragm Pump	23 lbs.	\$ 1,180.00
9910-D403GRGI	9.9	580	3600	3-Diaphragm Pump	23 lbs	\$ 2,148.00

PLEASE CONTACT US FOR ANY SPECIAL ORDER HYPRO PRODUCT REQUESTS

PRESSURE REGULATORS

The 1560A Electric Pressure Regulator is equipped with a precision high torque motor and gear reduction, and high strength valve body for heavy-duty service. Chemical resistant glass-filled nylon body, stainless steel motor shaft and butterfly, and viton seal. Low current draw, 50 MA at 12 volts. Maximum recommended pressure is 150 PSI. Speed at 12 volts is 1 RPM; at 6 volts is 1/2 RPM.

5143193 \$ 179.94
TIR 3/4" Pressure Regulator

5143224 \$ 205.60
TIR 1" Pressure Regulator



HONDA REPLACEMENT ENGINES

MFG Part #	FIMCO Code #	HP	Starter	Crankshaft Size	Oil Alert	List Price
GX160K1HX2	5152080	163cc	Rewind	Gear Reduction	Yes	\$ 1,379.93
GX160K1QX2	5152058	163cc	Rewind	3/4" Keyway	Yes	\$ 893.32
GX160K1TX2	5152086	163cc	Rewind	5/8" Threaded	Yes	\$ 997.98
GX240K1QAE2	5152090	270cc	Electric & Rewind	1" Keyway	Yes	\$ 2,047.77
GX240K1HA2	5152091	270cc	Rewind	Gear Reduction	Yes	\$ 2,092.80

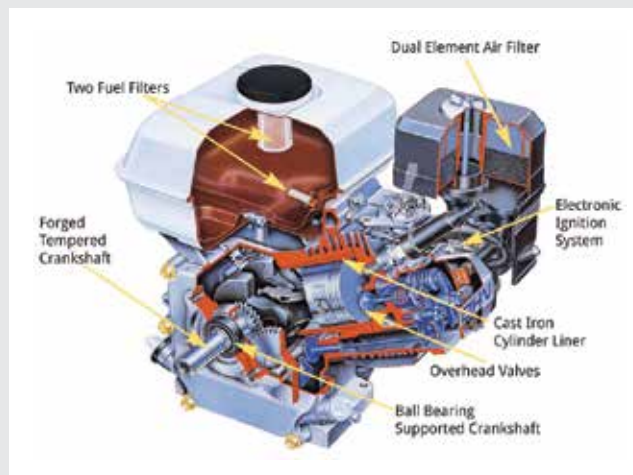

POLYPROPYLENE & NYLON FITTINGS

PRO SERIES SPRAYERS
UTV SPRAYERS
SPOT SPRAYERS
ATV SPRAYERS
TRAILER SPRAYERS
UTILITY & 3PT SPRAYERS
SKID SPRAYERS & BOOMS
PUMPS
SPRAYER ACCESSORIES
DRY MATERIAL SPREADERS
TRAILER CARTS & AERATORS
SPRAYER COMPONENTS
PARTS LIST BREAKDOWNS

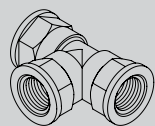

Female National Pipe Thread Tee

Description	POLYPROPYLENE			NYLON		
	FIMCO Code #	MFG Part #	List Price	FIMCO Code #	MFG Part #	List Price
1/4"	5010229	3TT14	\$ 4.58	5010154	TT14	\$ 4.94
1/2"	5010230	3TT12	\$ 5.43	5010113	TT12	\$ 6.38
3/4"	5010231	3TT34	\$ 6.38	5010089	TT34	\$ 7.85
1"	5010232	3TT100	\$ 9.99	5010130	TT100	\$ 12.48
1-1/4"	5010233	3TT114	\$ 11.54	5010131	TT114	\$ 16.02
1-1/2"	5010234	3TT112	\$ 16.29	5010132	TT112	\$ 15.59
2"	5010235	3TT200	\$ 20.70	5010133	TT200	\$ 23.27
3"	TEE300	TEE300	\$ 67.56			

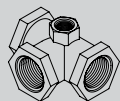

Female National Pipe Thread Tee With 1/4" Gauge Port

1/2"	5010256	3GTT1214	\$ 8.81	5010193	GTT1214	\$ 9.39
3/4"	5010257	3GTT3414	\$ 10.46	5010135	GTT3414	\$ 11.87

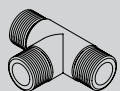

Male National Pipe Thread Tee

1/2" MNPT Tee	5010258	3R12	\$ 4.72			
---------------	---------	------	---------	--	--	--

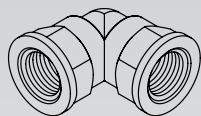

Female National Pipe Thread 90° Elbow

1/2"	5010236	3LL12	\$ 4.31	5010176	LL12	\$ 5.00
3/4"	5010237	3LL34	\$ 5.27	5010177	LL34	\$ 5.51
1"	5010238	3LL100	\$ 7.32	5010178	LL100	\$ 7.32
1-1/4"	5010239	3LL114	\$ 10.10	5010179	LL114	\$ 10.10
1-1/2"	5010240	3LL112	\$ 12.83	5010180	LL112	\$ 12.83
2"	5010241	3LL200	\$ 20.27	5010181	LL200	\$ 20.27
3"	5010260	EL300-90	\$ 57.89			

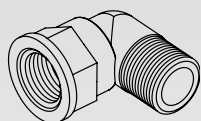

90° Street Elbow

1/4"	5010242	3SE14	\$ 2.69	5010137	SE14	\$ 3.06
3/8"	5010435	3SE38	\$ 1.87	5010343	SE38	\$ 3.75
1/2"	5010243	3SE12	\$ 3.36	5010148	SE12	\$ 3.66
3/4"	5010244	3SE34	\$ 4.35	5010144	SE34	\$ 4.61
3/4" - 45°	5010249	3SE3445	\$ 2.13	5010192	SE3445	\$ 4.25
1"	5010245	3SE100	\$ 8.10	5010146	SE100	\$ 8.10
1-1/4"	5010246	3SE114	\$ 10.32	5010147	SE114	\$ 10.32
1-1/2"	5010247	3SE112	\$ 11.63	5010149	SE112	\$ 11.81
2"	5010248	3SE200	\$ 13.35	5010145	SE200	\$ 15.06

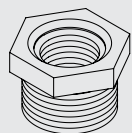

Hexagon Head Bushing MNPT x FNPT

3/8" x 1/4"	5041072	3RB3814	\$ 1.41	5041039	RB3814	\$ 1.41
1/2" x 1/4"	5041073	3RB1214	\$ 1.65	5041055	RB1214	\$ 1.52
1/2" x 3/8"	5041074	3RB1238	\$ 2.49	5041038	RB1238	\$ 2.49
3/4" x 1/8"	5041075	3RB3418	\$ 1.93	5041044	RB3418	\$ 1.98
3/4" x 1/4"	5041076	3RB3414	\$ 1.83	5041043	RB3414	\$ 1.65
3/4" x 3/8"	5041077	3RB3438	\$ 1.83	5041056	RB3438	\$ 1.65
3/4" x 1/2"	5041078	3RB3412	\$ 1.65	5041020	RB3412	\$ 1.65
1" x 1/2"	5041079	3RB10012	\$ 2.30	5041059	RB10012	\$ 3.12
1" x 3/4"	5041080	3RB10034	\$ 2.21	5041034	RB10034	\$ 2.93
1-1/4" x 3/4"	5041081	3RB11434	\$ 3.44	5041051	RB11434	\$ 4.14
1-1/4" x 1"	5041082	3RB114100	\$ 2.94	5041033	RB114100	\$ 3.56
1-1/2" x 1-1/4"	5041083	3RB112114	\$ 4.22	5041035	RB112114	\$ 5.69
2" x 1-1/4"	5041085	3RB200114	\$ 5.43	5041057	RB200114	\$ 7.25
2" x 1"	5041084	3RB200100	\$ 7.76	5041058	RB200100	\$ 8.37
2" x 1-1/2"	5041086	3RB200112	\$ 4.83	5041037	RB200112	\$ 6.38
3" x 1-1/2"	5041090	RB-300-150	\$ 21.88	5041052	RB300200	\$ 19.77
3" x 2"	5041087	3RB300200	\$ 21.27			

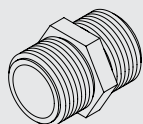

Pipe Nipples

1/4" x Close	5011137	3M14	\$ 0.74	5011110	M14	\$ 0.71
3/8" x Close	5011138	3M38	\$ 0.78	5011111	M38	\$ 0.72
1/2" x Close	5011139	3M12	\$ 0.83	5011054	M12	\$ 0.75
3/4" x Close	5011140	3M34	\$ 1.01	5011055	M34	\$ 0.93
1" x Close	5011141	3M100	\$ 1.25	5011095	M100	\$ 1.50
1-1/4" x Close	5011142	3M114	\$ 2.37	5011103	M114	\$ 2.57
1-1/2" x Close	5011143	3M112	\$ 3.96	5011104	M112	\$ 4.82

POLYPROPYLENE & NYLON FITTINGS

PRO SERIES SPRAYERS
UTV SPRAYERS
SPOT SPRAYERS
ATV SPRAYERS
TRAILER SPRAYERS
UTILITY & 3PT SPRAYERS
SKID SPRAYERS & BOOMS
PUMPS
SPRAYER ACCESSORIES
DRY MATERIAL SPREADERS
TRAILER CARTS & AERATORS
SPRAYER COMPONENTS
PARTS/ST BREAKDOWNS

POLYPROPYLENE

NYLON

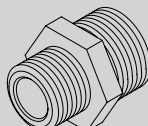
Description	POLYPROPYLENE			NYLON		
	FIMCO Code #	MFG Part #	List Price	FIMCO Code #	MFG Part #	List Price
 <p>Pipe Nipples</p>	1-1/2" x 4"	5011149	NIP150-4			\$ 9.69
	1-1/2" x 6"	5011150	NIP150-6			\$ 11.40
	2" x Close	5011144	3M200	5011105	M200	\$ 4.91
	2" x 4"	5011151	NIP200-4			\$ 9.38
	2" x 6"	5011152	NIP200-6			\$ 10.95
	3" x Short	5011148	NIP300-SH			\$ 13.95
	3" x 4"	5011153	NIP300-4			\$ 20.96
	3" x 6"	5011154	NIP300-6			\$ 27.03

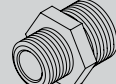
 <p>Reducing Pipe Nipples</p>	1/2" x 3/8"	5011145	3M1238	5011128	M1238	\$ 0.81
	3/4" x 3/8"	5011146	3M3438	5011114	M3438	\$ 0.92
	3/4" x 1/2"	5011147	3M3412	5011129	M3412	\$ 0.90

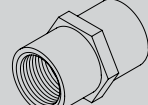
 <p>Pipe Couplings FNPT x FNPT</p>	1/2"	5010250	3FC12	5010182	FC12	\$ 3.75
	3/4"	5010251	3FC34	5010183	FC34	\$ 3.96
	1"	5010252	3FC100	5010184	FC100	\$ 4.31
	1-1/4"	5010253	3FC114	5010185	FC114	\$ 4.91
	1-1/2"	5010254	3FC112	5010186	FC112	\$ 6.32
	2"	5010255	3FC200	5010187	FC200	\$ 7.01
	3"	5010259	CPLG300			\$ 36.04

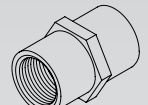
 <p>Reducing Pipe Couplings FNPT x FNPT</p>	1-1/2" x 1"	5010262	RC150-100			\$ 13.21
	1-1/2" x 1-1/4"	5010263	RC150-125			\$ 13.21
	2" x 1"	5010264	RC200-100			\$ 11.70
	2" x 1-1/4"	5010265	RC200-125			\$ 14.04
	2" x 1-1/2"	5010266	RC200-150			\$ 11.70
3" x 2"	5010267	RC300-200			\$ 41.53	

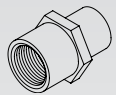
 <p>Coupling FGHT x FNPT (Reducing Coupling)</p>	3/4 FGHT x 1/2" FNPT	5005190	3J3412	5005170	J3412	\$ 2.85
--	----------------------	---------	--------	---------	-------	---------

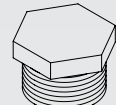
 <p>Pipe Plug</p>	1/8"	5102067	3F18	5102049	F18	\$ 0.68
	1/4"	5102068	3F14	5102022	F14	\$ 0.72
	3/8"	5102069	3F38	5102023	F38	\$ 0.75
	1/2"	5102070	3F12	5102024	F12	\$ 0.81
	3/4"	5102071	3F34	5102025	F34	\$ 0.86
	1"	5102072	3F100	5102026	F100	\$ 1.11
	1-1/4"	5102073	3F114	5102027	F114	\$ 1.68
	1-1/2"	5102075	3F112	5102085	F112	\$ 1.92
	2"	5102074	3F200	5102054	F200	\$ 2.49
	3"	5102076	PLUG300			\$ 22.91

 <p>Pipe Cap</p>	1-1/2"	5046127	CAP150			\$ 9.98
	2"	5046128	CAP200			\$ 11.57
	3"	5046129	CAP300			\$ 41.43

 <p>Male x Female Adapter</p>	1/2"FNPT x 3/4" MGHT Adapter	5005191	3G3412	5005023	GFA128	\$ 3.06
	3/4"FNPT x 3/4" MGHT Adapter	5005192	3G34	5005024	G34	\$ 2.85
	3/4"FGHT x 3/4" MNPT Adapter	5005193	3H34	5005026	H34	\$ 2.85

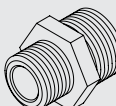
 <p>Male x Male Adapter</p>	3/8"MNPT x 3/4" MGHT Adapter	5005194	3E3438	5005020	E3438	\$ 0.93
	1/2"MNPT x 3/4" MGHT Adapter	5005195	3E3412	5005021	E3412	\$ 0.95
	3/4"MNPT x 3/4" MGHT Adapter	5005196	3E34	5005022	E34	\$ 0.93

POLYPROPYLENE & NYLON FITTINGS

POLYPROPYLENE

NYLON

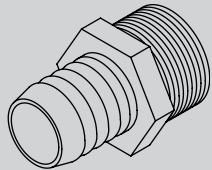

Male National Pipe Thread x Hose Barb

Description	FIMCO Code #	MFG Part #	List Price	FIMCO Code #	MFG Part #	List Price
3" x 3"	5067153	HB300	\$ 14.49			
2" x 2"	5067110	3A200	\$ 4.34	5067036	A200	\$ 5.21
1 - 1/2" x 1 - 1/2"	5067111	3A112	\$ 2.36	5067010	A112	\$ 2.85
1 - 1/2" x 1 - 1/4"	5067112	3A112114	\$ 2.22	5067095	A112114	\$ 2.69
1 - 1/4" x 1 - 1/2"	5067113	3A114112	\$ 2.36	5067093	A114112	\$ 2.85
1 - 1/4" x 1 - 1/4"	5067114	3A114	\$ 2.13	5067009	A114	\$ 2.69
1 - 1/4" x 1"	5067115	3A114100	\$ 1.92	5067072	A114100	\$ 2.49
1 - 1/4" x 3/4"	5067116	3A11434	\$ 1.95	5067094	A11434	\$ 2.49
1" x 1 1/4"	5067117	3A100114	\$ 1.88	5067008	A100114	\$ 2.22
1" x 1"	5067118	3A100	\$ 0.84	5067007	A100	\$ 0.98
1" x 3/4"	5067119	3A10034	\$ 1.28	5067086	A10034	\$ 1.26
3/4" x 3/8"	5067124	3A3438	\$ 0.95	5067011	A3438	\$ 0.87
3/4" x 1/2"	5067125	3A3412	\$ 0.96	5067012	A3412	\$ 0.92
3/4" x 5/8"	5067126	3A3458	\$ 0.95	5067013	A3458	\$ 0.92
3/4" x 3/4"	5067127	3A34	\$ 0.96	5010020	A34	\$ 0.93
3/4" x 1"	5067128	3A34100	\$ 1.13	5067014	A34100	\$ 1.25
1/2" x 1/4"	5067129	3A1214	\$ 0.78	5067015	A1214	\$ 0.75
1/2" x 3/8"	5067130	3A1238	\$ 0.84	5067016	A1238	\$ 0.81
1/2" x 1/2"	5067131	3A12	\$ 0.78	5067017	A12	\$ 0.83
1/2" x 5/8"	5067132	3A1258	\$ 0.84	5067018	A1258	\$ 0.81
1/2" x 3/4"	5067133	3A1234	\$ 0.84	5067019	A1234	\$ 0.83
3/8" x 1/4"	5067134	3A3814	\$ 0.75	5067020	A3814	\$ 0.69
3/8" x 3/8"	5067135	3A38	\$ 0.75	5010021	A38	\$ 0.72
3/8" x 1/2"	5067136	3A3812	\$ 0.81	5067021	A3812	\$ 0.74
1/4" x 1/4"	5067137	3A14	\$ 0.74	5067022	A14	\$ 0.69
1/4" x 3/8"	5067138	3A1438	\$ 0.72	5067005	A1438	\$ 0.71
1/4" x 1/2"	5067139	3A1412	\$ 0.75	5067023	A1412	\$ 0.71
1/8" x 1/4"	5067140	3A1814	\$ 0.75	5067024	A1814	\$ 0.65
1/8" x 3/8"	5067141	3A1838	\$ 0.75	5067035	A1838	\$ 0.68

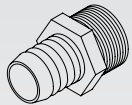

Male Garden Hose Thread x Hose Barb

3/4" x 3/8"	5067120	3D3438	\$ 0.95	5067025	D3438	\$ 0.96
3/4" x 1/2"	5067121	3D3412	\$ 0.96	5067026	D3412	\$ 0.95
3/4" x 5/8"	5067122	3D3458	\$ 0.90	5067027	D3458	\$ 0.87
3/4" x 3/4"	5067123	3D34	\$ 0.90	5067028	D34	\$ 0.92

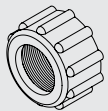

Swivel Nuts For Barbs Below

3/4" FGHT	5006209	3B34	\$ 0.57	5006055	B34	\$ 0.50
3/4" FNPT	5006210	3B35	\$ 1.71	5006056	B35	\$ 0.99
* 1" FNPT	5006211	3B100	\$ 3.56	5006155	B100	\$ 4.68

* Can Only Be Used With No. 5149038 1" Swivel Barb Below

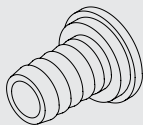

Swivel Barbs For Nuts Above

1/4" Swivel Barb	5149033	3C14	\$ 0.78	5149031	C14	\$ 0.63
3/8" Swivel Barb	5149034	3C38	\$ 0.78	5149010	C38	\$ 0.68
1/2" Swivel Barb	5149035	3C12	\$ 0.78	5149011	C12	\$ 0.69
5/8" Swivel Barb	5149036	3C58	\$ 0.78	5149012	C58	\$ 0.75
3/4" Swivel Barb	5149037	3C34	\$ 0.78	5149013	C34	\$ 0.66
* 1" Swivel Barb	5149038	3C100	\$ 1.47	5149030	C100	\$ 1.41

* Can Only Be Used With No. 5006211 1" Swivel Nut Above



Swivel Nut Gaskets

3/4" Barb Washer (G. H. Washer)	5016066	8330010	\$ 0.26			
1" Barb Washer	5016130	W405P	\$ 0.77			

POLYPROPYLENE & NYLON FITTINGS

PRO SERIES SPRAYERS
UTV SPRAYERS
SPOT SPRAYERS
ATV SPRAYERS
TRAILER SPRAYERS
UTILITY & 3PT SPRAYERS
SKID SPRAYERS & BOOMS
PUMPS
SPRAYER ACCESSORIES
DRY MATERIAL SPREADERS
TRAILER CARTS & AERATORS
SPRAYER COMPONENTS
PARTS/ST BREAKDOWNS

POLYPROPYLENE

NYLON

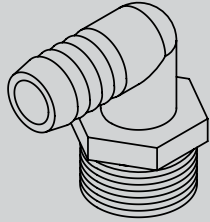

Male National Pipe Thread x Hose Barb 90° Elbow

Description MNPT x Hose Barb	FIMCO Code #	MFG Part #	List Price	FIMCO Code #	MFG Part #	List Price
1/4" x 1/2"	5010197	3EL1412	\$ 0.77	5010047	EL1412	\$ 1.14
1/4" x 3/8"	5010198	3EL1438	\$ 1.08	5010046	EL1438	\$ 0.73
1/4" x 5/8"				5010157	EL1458	\$ 2.57
3/8" x 1/4"	5010199	3EL3814	\$ 1.11	5010158	EL3814	\$ 1.16
3/8" x 3/8"	5010200	3EL38	\$ 0.83	5010042	EL38	\$ 1.17
3/8" x 1/2"	5010201	3EL3812	\$ 1.16	5010043	EL3812	\$ 1.20
3/8" x 3/4"				5010161	TLS63	\$ 2.72
1/2" x 3/8"	5010202	3EL1238	\$ 1.22	5010038	EL1238	\$ 1.23
1/2" x 1/2"	5010203	3EL12	\$ 1.23	5010039	ESSL12	\$ 1.25
1/2" x 5/8"	5010204	3EL1258	\$ 1.28	5010040	EL1258	\$ 1.41
1/2" x 3/4"	5010205	3EL1234	\$ 1.35	5010152	EL1234	\$ 1.46
3/4" x 3/8"	5010206	3EL3438	\$ 1.52	5010035	EL3438	\$ 1.52
3/4" x 1/2"	5010207	3EL3412	\$ 1.52	5010036	EL3412	\$ 1.53
3/4" x 5/8"	5010208	3EL3458	\$ 1.58	5010037	EL3458	\$ 1.53
3/4" x 3/4"	5010209	3EL34	\$ 1.61	5010028	EL34	\$ 1.56
3/4" x 1"	5010210	3EL34100	\$ 2.63	5010034	EL34100	\$ 2.79
1" x 1/2"	5010211	3EL10012	\$ 2.49	5010153	EL10012	\$ 2.57
1" x 3/4"	5010212	3EL10034	\$ 2.69	5010032	EL10034	\$ 2.57
1" x 1"	5010213	3EL100	\$ 3.44	5010033	EL100	\$ 2.79
1-1/4" x 3/4"	5010214	3EL11434	\$ 5.84	5010159	EL11434	\$ 6.21
1-1/4" x 1"	5010215	3EL114100	\$ 5.96	5010151	EL114100	\$ 4.91
1-1/4" x 1-1/4"	5010216	3EL114	\$ 4.14	5010100	EL114	\$ 4.49
1-1/4" x 1-1/2"	5010217	3EL114112	\$ 9.14	5010160	EL114112	\$ 9.29
1-1/2" x 1-1/2"	5010218	3EL112	\$ 7.76	5010143	EL112	\$ 8.18
2" x 2"	5010219	3EL200	\$ 8.18	5010150	EL200	\$ 9.74

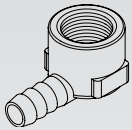

Female National Pipe Thread x Hose Barb 90° Elbow

3/4" x 1/2"	5010220	3EL3412F	\$ 3.15	5010114	EL3412F	\$ 3.42
3/4" x 3/4"	5010221	3EL34F	\$ 4.91	5010136	EL34F	\$ 3.56

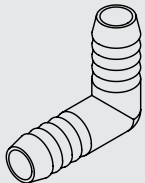

Hose Barb x Hose Barb 90° Elbow

1/4" x 1/4"				5010167	EL14HB	\$ 1.13
3/8" x 3/8"	5010222	3EL38HB	\$ 1.10	5010168	EL38HB	\$ 1.13
1/2" x 1/2"	5010223	3EL12HB	\$ 1.10	5010170	EL12HB	\$ 1.16
3/4" x 3/4"	5010224	3EL34HB	\$ 1.40	5010171	EL34HB	\$ 1.41
1" x 1"				5010172	EL100HB	\$ 2.69
1-1/4" x 1-1/4"				5010173	EL114HB	\$ 6.24
1-1/2" x 1-1/2"				5010174	EL112HB	\$ 6.54
2" x 2"				5010175	EL200HB	\$ 9.96

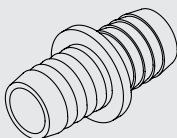

Hose Mender

1/4"	5067142	3SHM14	\$ 0.72	5067074	SHM14	\$ 0.66
3/8"	5067143	3SHM38	\$ 0.74	5067029	SHM38	\$ 0.69
1/2"	5067144	3SHM12	\$ 0.75	5067030	SHM12	\$ 0.72
5/8"	5067145	3SHM58	\$ 0.84	5067077	SHM58	\$ 0.87
3/4"	5067146	3SHM34	\$ 0.96	5067031	SHM34	\$ 1.11
1"	5067147	3SHM100	\$ 1.25	5067032	SHM100	\$ 1.49
1-1/4"	5067148	3SHM114	\$ 2.04	5067084	SHM114	\$ 2.49
1-1/2"	5067149	3SHM112	\$ 3.32	5067085	SHM112	\$ 4.28
2"	5067150	3SHM200	\$ 9.65	5067097	SHM200	\$ 15.26

POLYPROPYLENE & NYLON INSERTS

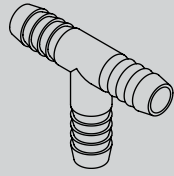

Hose Barb Tee

Description Hose Barb Size	POLYPROPYLENE			NYLON		
	FIMCO Code #	MFG Part #	List Price	FIMCO Code #	MFG Part #	List Price
1/4" x 1/4" x 1/4"	5086024	3T14	\$ 1.37	5086013	T14	\$ 1.14
3/8" x 3/8" x 3/8"	5086025	3T38	\$ 1.20	5086002	T38	\$ 1.20
1/2" x 1/2" x 1/2"	5086026	3T12	\$ 0.81	5086003	T12	\$ 0.84
1/2" x 1/2" x 3/8"	5086027	3T3812	\$ 2.10	5086016	T3812	\$ 1.23
1/2" x 1/2" x 3/4"	5086028	3T3412	\$ 3.56	5086017	T3412	\$ 3.65
5/8" x 5/8" x 5/8"	5086029	3T58	\$ 1.52	5086008	T58	\$ 1.28
3/4" x 3/4" x 3/4"	5086030	3T34	\$ 1.02	5086004	T34	\$ 1.49
1" x 1" x 1"	5086031	3T100	\$ 4.35	5086005	T100	\$ 2.27
1-1/4" x 1-1/4" x 1-1/4"	5086032	3T114	\$ 4.98	5086007	T114	\$ 4.47
1-1/2" x 1-1/2" x 1-1/2"	5086033	3T112	\$ 4.91	5086014	T112	\$ 5.16
2" x 2" x 2"	5086034	3T200	\$ 16.28	5086018	T200	\$ 16.82



Hose Barb Nozzle
Body Cross

3-3/8" Hose Barb.	5056092	3T38C	\$ 4.05	5272127	T38C	\$ 4.22
3-1/2" Hose Barb.	5056093	3T12C	\$ 4.05	5271920	T12C	\$ 4.31



Hose Barb Nozzle
Body Elbow

Fits 3/8" Hose	5056094	3NTL38	\$ 1.74	5056024	NTL38	\$ 1.88
Fits 1/2" Hose	5056095	3NTL12	\$ 1.74	5056023	NTL12	\$ 1.88
Fits 5/8" Hose	5056096	3NTL58	\$ 2.21	5056061	NTL58	\$ 2.30
Fits 3/4" Hose	5056097	3NTL34	\$ 2.42	5056057	NTL34	\$ 2.12



Hose Barb Nozzle
Body Tee

Fits 3/8" Hose	5056098	3NTT38	\$ 1.97	5056028	NTT38	\$ 1.92
Fits 1/2" Hose	5056099	3NTT12	\$ 1.97	5056027	NTT12	\$ 1.97
Fits 5/8" Hose	5056100	3NTT58	\$ 3.06	5056062	NTT58	\$ 2.42
Fits 3/4" Hose	5056101	3NTT34	\$ 2.57	5056056	NTT34	\$ 3.05

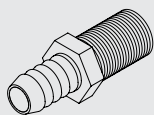

Hose Barb Nozzle
Body Straight

5002246	8400-T-406-NYB	\$ 2.64
---------	----------------	---------

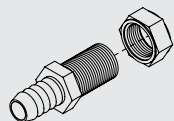

Hose Barb Nozzle
Long Shank Body
w/Locknut - Straight

3/8" H.B.	5002396	338D	\$ 1.58			
1/2" H.B.	5002397	33812D	\$ 1.58	5002359	3812D	\$ 1.65



Swivel Barb
(Fits Nozzle Cap)

3/8" H.B.	5149039	3K8438	\$ 0.69	5149019	K8438	\$ 0.72
1/2" H.B.	5149040	3K8412	\$ 0.71	5149014	K8412	\$ 0.83

PRO SERIES SPRAYERS
UTV SPRAYERS
SPOT SPRAYERS
ATV SPRAYERS
TRAILER SPRAYERS
UTILITY & 3PT SPRAYERS
SKID SPRAYERS & BOOMS
PUMPS
SPRAYER ACCESSORIES
DRY MATERIAL SPREADERS
TRAILER CARTS & AERATORS
SPRAYER COMPONENTS
PARTS LIST BREAKDOWNS

HOSE INSERTS & NYLON QUICK COUPLERS

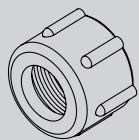

Nozzle Cap
(Swivel Nut)

POLYPROPYLENE				NYLON		
Description	FIMCO Code #	MFG Part #	List Price	FIMCO Code #	MFG Part #	List Price
Nozzle Cap	5046126	38027	\$ 0.42	5046052	8027	\$ 0.39
Blank Nozzle Cap	5046131	33942	\$ 0.39	5046130	3942	\$ 0.42

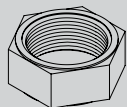

Nozzle Cap
Thread Locknut

Description	FIMCO Code #	MFG Part #	List Price	FIMCO Code #	MFG Part #	List Price
Lock Nut, NPS	5006212	3B12	\$ 0.38	5006184	B12	\$ 0.39

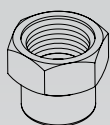

Adapter Nozzle Cap
Thread x 1/4" FNPT

Description	FIMCO Code #	MFG Part #	List Price	FIMCO Code #	MFG Part #	List Price
Adapter	5005137	4676-NYB-1/4	\$ 2.63			

NYLON QUICK COUPLER FOR HOSE

Hose savers are a three piece assembly - hose barb, fly nut and nipple - that allows you to disconnect hose from your pump without cutting or removing the hose.

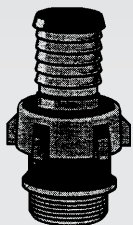

Hose Saver
Straight Assembly

MNPT	Description	FIMCO Code #	MFG Part #	List Price
3/4"	3/4"	5149053	626320N	\$ 9.74
3/4"	1'	5149054	626325N	\$ 11.46
1"	3/4"	5149055	626420N	\$ 13.41
1"	1"	5149056	626425N	\$ 11.19
1 - 1/4"	1"	5149058	626525N	\$ 13.35
1 - 1/4"	1 - 1/4"	5149059	626532N	\$ 13.53
1 - 1/4"	1 - 1/2"	5149060	626538N	\$ 12.14
1 - 1/2"	1 - 1/4"	5149061	626632N	\$ 14.12
1 - 1/2"	1 - 1/2"	5149062	626638N	\$ 17.06
1 - 1/2"	2"	5149063	626651N	\$ 26.33

- Nylon material safe for most ag chemicals
- 150 PSI Rating
- Sizes, 3/4" Thru 2"

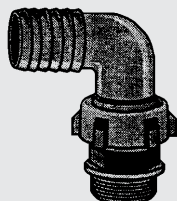









Hose Saver
Elbow Assembly

MNPT	Description	FIMCO Code #	MFG Part #	List Price
3/4"	3/4"	5149065	627320N	\$ 7.24
3/4"	1"	5149066	627325N	\$ 8.90
1"	3/4"	5149067	627420N	\$ 7.24
1"	1"	5149068	627425N	\$ 8.90
1"	1 - 1/4"	5149069	627432N	\$ 10.11
1 - 1/4"	1"	5149070	627525N	\$ 10.57
1 - 1/4"	1 - 1/4"	5149071	627532N	\$ 10.97
1 - 1/4"	1 - 1/2"	5149072	627538N	\$ 20.37
1 - 1/2"	1 - 1/4"	5149073	627632N	\$ 12.64
1 - 1/2"	1 - 1/2"	5149074	627638N	\$ 17.22
1 - 1/2"	2"	5149075	627651N	\$ 30.96
2"	2"	5149076	627751N	\$ 24.11

POLYPROPYLENE QUICK COUPLERS FOR HOSES

BANJO POLYPROPYLENE

NORWESCO POLYPROPYLENE

	BANJO POLYPROPYLENE				NORWESCO POLYPROPYLENE		
	Description	FIMCO Code #	MFG Part #	List Price	FIMCO Code #	MFG Part #	List Price
 <p>A / Male Adapter Female Thread</p>	3/4"	5005156	75A3/4	\$ 5.62	5005260	61207	\$ 4.06
	1"	5005138	100A	\$ 5.62	5005261	61215	\$ 4.32
	1-1/4"	5005157	125A	\$ 5.62	5005262	61223	\$ 4.62
	1-1/2"	5005139	150A	\$ 6.39	5005263	61231	\$ 4.81
	2"	5005140	200A	\$ 7.53	5005264	61239	\$ 5.70
	3"	5005153	300A	\$ 18.19	5005265	61247	\$ 12.93
	4"	5005253	400A	\$ 33.30	5005254	62789	\$ 21.65
 <p>F / Male Adapter Male Thread</p>	3/4"	5005158	075F	\$ 6.08	5005266	61212	\$ 4.38
	1"	5005141	100F	\$ 6.75	5005267	61220	\$ 4.95
	1-1/4"	5005159	125F	\$ 6.75	5005268	61228	\$ 4.99
	1-1/2"	5005142	150F	\$ 6.77	5005269	61236	\$ 5.15
	2"	5005143	200F	\$ 8.89	5005270	61244	\$ 6.62
	3"	5005154	300F	\$ 23.31	5005271	61252	\$ 16.31
	4"	5005255	400F	\$ 33.30	5005256	62794	\$ 21.65
 <p>E / Male Adapter Hose Shank</p>	3/4"	5005160	075E	\$ 6.08	5005272	61211	\$ 4.38
	1"	5005144	100E	\$ 6.75	5005273	61219	\$ 4.95
	1-1/4"	5005161	125E	\$ 6.75	5005274	61227	\$ 4.99
	1-1/2"	5005145	150E	\$ 6.77	5005275	61235	\$ 5.15
	2"	5005146	200E	\$ 8.89	5005276	61243	\$ 6.62
	3"	5005155	300E	\$ 23.31	5005277	61251	\$ 16.31
	4"	5005257	400E	\$ 33.30	5005258	62793	\$ 21.65
 <p>D / Female Coupler Female Thread</p>	3/4"	5057107	075D	\$ 12.86	5057180	61261	\$ 10.65
	1"	5057092	100D	\$ 14.77	5057181	61265	\$ 12.16
	1-1/4"	5057108	125D	\$ 14.77	5057182	61269	\$ 14.47
	1-1/2"	5057093	150D	\$ 17.32	5057183	61273	\$ 14.41
	2"	5057094	200D	\$ 21.09	5057184	61277	\$ 16.94
	3"	5057102	300D	\$ 35.45	5057185	61281	\$ 28.63
	4"	BJ400D	400D	\$ 70.25	5057201	62792	\$ 57.46
 <p>B / Female Coupler Male Thread</p>	3/4"	5057109	75B3/4	\$ 12.86	5057186	61259	\$ 10.65
	1"	5057095	100B	\$ 14.77	5057187	61263	\$ 12.16
	1-1/4"	5057110	125B	\$ 14.77	5057188	61267	\$ 14.47
	1-1/2"	5057096	150B	\$ 17.32	5057189	61271	\$ 14.41
	2"	5057097	200B	\$ 21.09	5057190	61275	\$ 16.94
	3"	5057103	300B	\$ 35.45	5057191	61279	\$ 28.63
	4"	5057202	400B	\$ 84.29	5057203	62790	\$ 57.46
 <p>C / Female Coupler Hose Shank</p>	3/4"	5057111	075C	\$ 12.86	5057192	61260	\$ 10.65
	1"	5057098	100C	\$ 14.77	5057193	61264	\$ 12.16
	1-1/4"	5057112	125C	\$ 14.77	5057194	61268	\$ 14.47
	1-1/2"	5057099	150C	\$ 17.32	5057195	61272	\$ 14.41
	2"	5057100	200C	\$ 21.09	5057196	61276	\$ 16.94
	3"	5057104	300C	\$ 35.45	5057197	61280	\$ 28.63
	4"	5057204	400C	\$ 57.46	5057205	62791	\$ 57.46
 <p>PL / Plug For Female Coupler</p>	3/4"	5102048	75PL	\$ 6.08	5120110	61214	\$ 3.95
	1"	5102044	100125PL	\$ 5.84	5120111	61222	\$ 4.32
	1-1/4"	5102044	100125PL	\$ 5.84	5120112	61238	\$ 4.77
	1-1/2"	5102045	150PL	\$ 7.84	5120112	61238	\$ 4.77
	2"	5102046	200PL	\$ 8.82	5120114	61246	\$ 6.44
	3"	5102047	300PL	\$ 18.48	5120115	61254	\$ 12.93
	4"	5102119	400PL	\$ 26.17	5102120	62796	\$ 17.39
 <p>CAP / Cap For Male Adapter</p>	3/4"	5046090	075CAP	\$ 12.86	5046350	61258	\$ 10.65
	1"	5046077	100125CAP	\$ 14.19	5046351	61266	\$ 11.80
	1-1/4"	5046077	100125CAP	\$ 14.19	5046352	61274	\$ 14.41
	1-1/2"	5046078	150CAP	\$ 17.32	5046352	61274	\$ 14.41
	2"	5046079	200CAP	\$ 21.09	5046354	61278	\$ 16.94
	3"	5046083	300CAP	\$ 35.45	5046355	61282	\$ 28.63
	4"	5046371	400CAP	\$ 51.23	5046372	62795	\$ 42.72
 <p>Gasket For Couplers</p>	3/4"	5072277	75G	\$ 1.01	5072482	61570	\$ 1.12
	1"	5072214	100G	\$ 1.01	5072483	61571	\$ 0.62
	1-1/4"	5072214	100G	\$ 1.01	5072484	61572	\$ 0.94
	1-1/2"	5072215	150G	\$ 1.08	5072484	61572	\$ 0.94
	2"	5072216	200G	\$ 1.14	5072486	61574	\$ 1.15
	3"	5072278	300G	\$ 1.56	5072487	61575	\$ 1.45
	4"	5072504	400G	\$ 3.66	5072505	62797	\$ 3.66

SPRAYER HOSE, CLAMPS & CUTTER

HOSE

			BULK ROLL			BOXED LENGTHS		
I.D. Size	# of Braids	Working Pressure	FIMCO Code #	Feet On Roll	Price Per Foot	FIMCO Code #	Feet Per Box	Price Per Foot
3/8	1	150	5153076	*	\$ 0.90	5550001	100	\$ 101.00
3/8	2	250	5153077	*	\$ 1.44	5550002	100	\$ 134.68
1/2	1	150	5153079	*	\$ 1.40	5550003	100	\$ 182.24
1/2	2	250	5153080	*	\$ 2.16	5550004	100	\$ 181.14
5/8	1	150	5153082	*	\$ 1.67	5550005	100	\$ 165.90
3/4	1	150	5153084	*	\$ 2.16	5550007	100	\$ 205.57
3/4	2	250	5153085	*	\$ 2.50	5550008	100	\$ 275.02
1	2	150	5153087	*	\$ 3.89	5550010	100	\$ 376.00
1-1/4	2	150	5153088	**	\$ 6.34	5550011	50	\$ 302.02
1-1/2	2	150	5153089	**	\$ 6.95	5550012	50	\$ 388.21

Note: Full Rolls vary *600 ft. to 700 ft. - **300 ft. to 400 ft.



Note: 1 Braid = 2 Spiral Braid
2 Braid = 4 Spiral Braid

I.D. Size	Working Pressure	FIMCO Code #	Feet On Roll	Price Per Roll
3/8	275	5153113	300	\$ 368.16
1/2	275	5153114	300	\$ 469.49
3/4	250	5153115	200	\$ 642.60

PVC CLEAR REINFORCED VINYL TUBING

*Sold Only In Full Rolls



I.D. Size	Working Pressure	FIMCO Code #	Feet On Roll	Price Per Roll
1-1/2	Open Discharge	5153121	300	\$ 356.93
2	Open Discharge	5153120	100	\$ 124.24
2	Open Discharge	5153098	300	\$ 372.44

PVC LAY FLAT DISCHARGE HOSE

*Sold Only In 100' & 300' Rolls



PVC SUCTION HOSE ASSEMBLY

FIMCO Code #	Size & Description	List Price
5272172	2" x 20' PVC Suction Hose Assembly Coupled w/1/2" MNPT x 1/2" FNPT	\$ 114.17

STAINLESS STEEL WORM DRIVEN HOSE CLAMPS



FIMCO Code #	MFG Part #	Fits Hose (Inside Diameter)	List Price
5051020	6202062	1/8" to 1/4"	\$ 1.31
5051021	5206052	3/8" to 1/2"	\$ 1.02
5051022	5208052	1/2" to 5/8"	\$ 1.31
5051023	5210052	5/8" to 3/4"	\$ 1.36
5051024	5212052	3/4" to 1"	\$ 1.41
5051025	5216052	1" to 1-1/4"	\$ 1.45
5051026	5224052	1-1/4" to 1-1/2"	\$ 1.58
5051027	5228052	1-1/2" to 2"	\$ 1.65

HOSE & PIPE CUTTER



li'l nipper™

Cuts: Polyethylene - Polybutylene
PVC - ABS - Rubber hose

- Fast - Clean - Safe - Small - Light
- Strong tough nylon handles
- Replaceable stainless steel blades

CLEAN
SMOOTH
CUT



FIMCO Code #	Description	List Price
5271981	Li'l Nipper Hose Cutter (Cuts up to 1-1/4" ID Hose)	\$ 32.94
5273224	Li'l Nipper Hose Cutter (Cuts up to 2" ID Hose)	\$ 40.13

PRESSURE GAUGES



1/4" Back Fitting

High Pressure, Plastic Case, Dry Gauge



1/4" Bottom Fitting
Chemical Or Ammonia Gauges

WARNING: BRASS STEM GAUGES ARE NOT TO BE USED WITH AMMONIA



1/4" Bottom Fitting

High Pressure, Stainless Steel Case, Liquid Filled, Chemical Gauges



FIMCO Code #	MFG Part #	Size	List Price
1/4" MIPT - Plastic Stem - 2" Face Back Mount			
5167097	-	0-100 PSI	\$ 10.08
1/4" MIPT - Plastic Stem - 2" Face			
5167006	SG602	0-60 PSI	\$ 8.15
5167007	SG1002	0-100 PSI	\$ 8.26
5167004	SG2002	0-200 PSI	\$ 8.15
5167005	L20	0-400 PSI	\$ 8.26
5167001	L23	0-600 PSI	\$ 7.38
1/4" MIPT - Brass Stem - 2 1/2" Face			
5167017	SG60	0-60 PSI	\$ 9.49
5167018	SG100	0-100 PSI	\$ 9.74
5167019	SG200	0-200 PSI	\$ 9.23
5167020	SG300	0-300 PSI	\$ 8.44
5167066	SG400	0-400 PSI	\$ 9.48
1/4" MIPT - Brass Stem - 4" Face			
5167026	SG604	0-60 PSI	\$ 21.05
5167022	SG1004	0-100 PSI	\$ 23.92
5167033	SG2004	0-200 PSI	\$ 23.80
1/4" MIPT - Ammonia Gauge - 2 1/2" Face			
5167011	ASG60	0-60 PSI	\$ 26.56
5167010	ASG160	0-160 PSI	\$ 26.24

1/4" MIPT - Liquid Filled - Stainless Steel Case - 2-1/2" Face

5167031	CG100	0-100 PSI	\$ 21.10
5167080	CG200	0-200 PSI	\$ 20.70
5167034	CG400	0-400 PSI	\$ 20.70
5167029	CG600	0-600 PSI	\$ 20.70
5167030	GG1000	0-1000 PSI	\$ 20.70
5167015	GG1500	0-1500 PSI	\$ 21.17
*5167027	GG2000	0-2000 PSI	\$ 21.84
*5167028	GG3000	0-3000 PSI	\$ 20.70

* Discontinued-Available only until present stock depleted.

Accessories For Gauges

5273051	23800A-1/8	Isolator Kit 1/8"	\$ 129.50
5273294	23800A-1/4	Isolator Kit 1/4"	\$ 129.50

PRO SERIES SPRAYERS
UTV SPRAYERS
SPOT SPRAYERS
ATV SPRAYERS
TRAILER SPRAYERS
UTILITY & 3PT SPRAYERS
SKID SPRAYERS & BOOMS
PUMPS
SPRAYER ACCESSORIES
DRY MATERIAL SPREADERS
TRAILER CARTS & AERATORS
SPRAYER COMPONENTS
PARTSLIST BREAKDOWNS

VALVES

std = standard port fp = full port



POLY BOLTED BALL VALVE STAINLESS STEEL BOLTS, NUTS & WASHERS

FIMCO Code #	MFG Part #	Size	List Price
5143361	60540	1/2" fp	\$ 29.89
5143362	60541	3/4" fp	\$ 29.89
5143363	60542	1" std	\$ 29.89
5143364	60543	1" fp	\$ 35.03
5143365	61734	1-1/4" std	\$ 35.03
5143366	60527	1-1/4" fp	\$ 44.17
5143367	60526	1-1/2" fp	\$ 44.17
5143368	60529	2" std	\$ 43.46
5143369	60528	2" fp	\$ 61.84
5143370	61720	3" fp	\$ 149.06
5143396	62787	4" fp	\$ 318.08

POLY BOLTED BALL VALVE WITH MALE NIPPLE



5143371	62046	2" std	\$ 43.46
5143372	61876	2" fp	\$ 64.79
5143373	62047	3" fp	\$ 149.06

ANGLE VALVE



5143374	60544	1-1/2" fp	\$ 60.41
5143375	60545	2" std	\$ 61.85
5143376	60546	2" fp	\$ 86.11

SINGLE UNION BALL VALVE



5143205	60409	1/2"	\$ 12.72
5143206	60410	3/4"	\$ 14.11
5143207	60411	1"	\$ 17.95
5143208	60412	1-1/4"	\$ 29.44
5143209	60413	1-1/2"	\$ 36.51
5143210	60414	2"	\$ 46.53
5143377	60415	3"	\$ 138.35
5143378	60479	1"/45° Nozzle Valve	\$ 18.71

MULTI-PORT BALL VALVE



5143379	60417	3/4" True Union	\$ 40.93
5143380	60418	2" Multi-Port	\$ 58.19

POLY COMPACT BALL VALVE STAINLESS STEEL BOLTS, NUTS & WASHERS



5143381	62286	2" fp/mpt x fpt	\$ 50.27
5143382	62287	2" fp/fpt x fpt	\$ 50.27
5143383	62288	2" fp/mpt x male Coupler	\$ 50.27
5143384	62314	2" fp/fpt x male Coupler	\$ 50.27



VALVES

CELCON GLOBE VALVE - FIPT



<u>FIMCO Code #</u>	<u>MFG Part #</u>	<u>Size</u>	<u>List Price</u>
5143107	SCL-0500T	1/2"	\$ 11.70
5143123	SCL-0750T	3/4"	\$ 12.33

POLY BALL VALVE



5143220	V075	3/4"	\$ 42.74
5143144	V100	1"	\$ 42.74
5143173	V125	1-1/4"	\$ 47.12
5143142	V150	1-1/2"	\$ 60.58
5143143	V200	2"	\$ 60.58
5143161	V300	3"	\$ 137.32

FULL PORT POLY BALL VALVE



5143312	V100FP	1"	\$ 47.12
5143222	V200FP	2"	\$ 85.31
5143223	V300FP	3"	\$ 203.86

BRASS BALL VALVE



5143211	101-302	3/8"	\$ 12.66
5143197	101-303	1/2"	\$ 11.78
5143190	101-304	3/4"	\$ 16.54
5143191	101-305	1"	\$ 25.13

POLY MANIFOLD



<u>FIMCO Code #</u>	<u>MFG Part #</u>	<u>Description</u>	<u>PORT SIZE</u>		<u>List Price</u>
			<u>Inlet</u>	<u>Outlet</u>	
5143358	TMO75/050	Poly Manifold	(1)3/4"	(8)1/2" - 1/4"	\$ 42.57

ALUMINUM MANIFOLD BY-PASS VALVE



5143066	2142-2	Aluminum Manifold-By-Pass 0-600 PSI	(1)1/2"	(3)3/8" - (1)1/4"	\$ 73.35
---------	--------	--	---------	----------------------	----------

HAMILTON NYLON REGULATORY VALVE



5143336	2064-05-58	Nylon Pressure Relief Valve	(1)1/2"	(1) 3/4"	\$ 23.23
5143337	2066-05-58	Nylon Pressure Relief Valve	(1)3/4"	(1) 3/4"	\$ 23.23

PRO SERIES SPRAYERS
UTV SPRAYERS
SPOT SPRAYERS
ATV SPRAYERS
TRAILER SPRAYERS
UTILITY & 3PT SPRAYERS
SKID SPRAYERS & BOOMS
PUMPS
SPRAYER ACCESSORIES
DRY MATERIAL SPREADERS
TRAILER CARTS & AERATORS
SPRAYER COMPONENTS
PARTSLIST BREAKDOWNS

PRESSURE RELIEF VALVES



FIMCO Code #	NPT Size	Description	List Price
5271298	8460-1/2 w/ 1/2" NPT Connections	Nylon Valve	\$ 72.64
5271299	8460-3/4 w/ 3/4" NPT Connections	Nylon Valve	\$ 72.64

Bypasses excess liquid. Choice of 1/2" and 3/4" NPT sizes. Chemical resistant diaphragm seals off operating parts from contact with chemicals remains resilient for chatter-free, responsive pressure control.

Nylon inlet body with aluminum bonnet. Choice of 1/2" or 3/4" NPT (M) inlet and (F) outlet connections. Flow rates to 56 GPM for 1/2" size and to 70 GPM for 3/4" size.

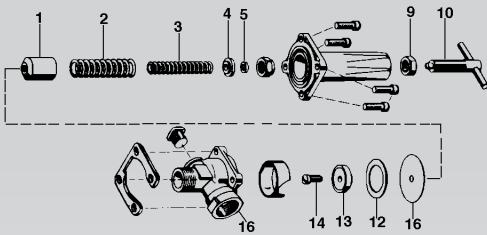

Ref #	FIMCO Code #	MFG Part #	Description	List Price
1	5124023	CP8367-AL	Guide Sleeve	\$ 8.65
*2	Available In Kit Only		Outside Spring	
*3	Available In Kit Only		Inside Spring	
4	5108026	CP8371-AL	Spring Retainer	\$ 4.66
*5	Available In Kit Only		Washer, Nylon	
9	5006073	CP5898-AL	Lock Nut	\$ 2.09
10	5271372	CP5896-AL SS	Adjusting Stem	\$ 9.65
*11	Available In Kit Only		Diaphragm	
12	5110079	CP8365-304SS	Stop Ring	\$ 5.27
*13	Available In Kit Only		Seat, Nylon	
14	5117091	CP8477-IZP	Screw	\$ 1.73
16	5002244	CP8361-1/2 NYB	Body, Nylon 1/2"	\$ 16.87
16	5002245	CP8361-3/4 NYB	Body, Nylon 3/4"	\$ 16.87
*	5168186	PK-AB8460-KIT	Repair Parts Kit-Marked w/*	\$ 26.22

PISTON TYPE PRESSURE RELIEF/REGULATING VALVES



Model 6815

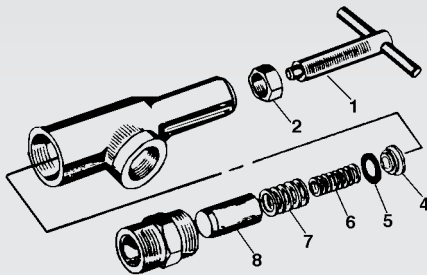

Ref #	FIMCO Code #	MFG Part #	Description	List Price
	5143031	6815-1/2-300	Brass Valve (0-300 PSI)	\$ 84.31
	5143034	6815-3/4-300	Brass Valve (0-300 PSI)	\$ 84.31
1	5271372	CP5896-ALSS	Stem, Aluminum & SS	\$ 9.65
2	5006085	CP5898	Lock Nut, Brass	\$ 2.09
2	5006073	CP5898-AL	Lock Nut, Aluminum	\$ 2.09
x4	CP6545	Available In Kit Only	Spring Retainer, Brass	\$ 2.09
x*5	CP5899-BU	Available In Kit Only	Gasket	\$ 1.73
x*6	CP6547-SS	Available In Kit Only	Inside Spring	\$ 3.64
x*7	CP6546-SS	Available In Kit Only	Outside Spring	\$ 4.19
*8	CP6544-AL	Available In Kit Only	Guide Seat, Aluminum	\$ 8.67
	5168379	PK-AB6815-300-KIT	Brass Repair Kit Marked x	\$ 18.35

- Brass with stainless steel springs. • Choice of 1/2" or 3/4" NPT (M) inlet & (F) outlet connections.
- For pressures to 300 P.S.I.

PISTON TYPE PRESSURE RELIEF/REGULATING VALVES

Bypasses excess liquid. Adjustable to maintain control of line pressure at any pressure within the valve operating range. Selected pressure setting firmly held in place by locknut. Extra large valve passages to handle large flows.



Spraying Systems Co.

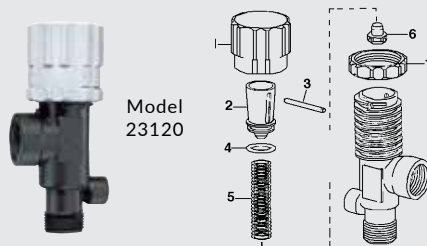

Model 23120

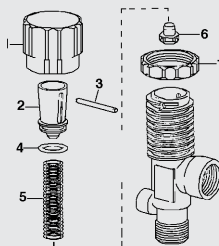

- Polypropylene with stainless steel spring
- Excellent chemical resistance
- EPDM O Rings
- For pressures to 150 psi
- 1/4" port for pressure gauge
- Choice of 1/2" or 3/4" NPT (M) inlet & (F) outlet connections

Ref #	FIMCO Code #	MFG Part #	Description	List Price
	5143200	23120-1/2-PP	1/2" Poly Valve	\$ 39.57
	5143199	23120-3/4-PP	3/4" Poly Valve	\$ 39.57
1	5046270	CP23122-NY	Adjusting Cap	\$ 12.67
*3	Available In Kit Only		Retainer Pin	
*4	Available In Kit Only		O Ring Gasket	
*5	Available In Kit Only		Spring	
6	5115078	CP23125-PP	Guide Seat	\$ 4.98
7	5110266	CP23123-PP	Lock Ring	\$ 6.79
*	5168717	PK-AB23120-KIT	Repair Kit Items Marked *	\$ 19.53

How to Order: Specify valve no. Example: 23120-1/2-PP Polypropylene

LINE STRAINERS

AA126 FLUSH-OUT LINE STRAINER



MFG Part #	Description	List Price
AA126ML-3-30	3/4" Strainer w/30 Mesh	\$ 37.56
AA126ML-3-50	3/4" Strainer w/50 Mesh	\$ 37.56
AA126ML-3-80	3/4" Strainer w/80 Mesh	\$ 37.56
AA126ML-4-30	1" Strainer w/30 Mesh	\$ 37.56
AA126ML-4-50	1" Strainer w/50 Mesh	\$ 37.56
AA126ML-5-30	1-1/4" Strainer w/30 Mesh	\$ 76.88
AA126ML-5-50	1-1/4" Strainer w/50 Mesh	\$ 76.88
AA126ML-6-30	1-1/2" Strainer w/30 Mesh	\$ 76.88

- 200 PSI (14 bar) max pressure rating
- Strainer head and bowl are made of glass-filled polypropylene with EPDM gasket
- Removable cap and gasket for flush-out or self-cleaning operations.
- Screens are made of 304SS with color-coded polypropylene frame and are removable for cleaning
- Integral mounting provision allows the strainer to be attached to machine using M10 or 3/8" diameter bolts
- Available with 3/4", 1" NPT or BSPT (F) threads and 50 or 75 series flange fitting connections or easy assembly
- Uses same screen as the AA124 line strainer

NYLON LINE STRAINER 3/4" - 1" - 1-1/4" & 1-1/2"



Complete Strainers	FIMCO Code #	MFG Part #	Description	List Price
	5116236	AA126ML-4-50	1" Nylon Strainer w/50 mesh Screen	\$ 37.56
Gaskets	5072245	CP7717-2/226-VI	Bowl Gasket, Viton for 3/4" & 1"	\$ 13.59
	5072221	CP12291-VI	Bowl Gasket, Viton for 1 1/4" & 1 1/2"	\$ 17.36
Screens	5116192	CP16903-3-SSPP	30 Mesh Screen for 3/4" & 1" Strainer	\$ 15.08
	5116193	CP16903-4-SSPP	50 Mesh Screen for 3/4" & 1" Strainer	\$ 15.08
	5116186	CP15941-2-SSPP	30 Mesh Screen for 1 1/4" & 1 1/2" Strainer	\$ 21.24
	5116187	CP15941-3-SSPP	50 Mesh Screen for 1 1/4" & 1 1/2" Strainer	\$ 21.24
Bowls	5058098	CP15403-NY	Bowl, Nylon for 3/4" & 1" Strainer	\$ 32.92
	5058099	CP12288-NY	Bowl, Nylon for 1 1/4" & 1 1/2" Strainer	\$ 57.19

- Easy Maintenance
- No tools required
- Reinforced Nylon bowls removed by hand for quick, efficient screen cleaning
- For operating pressures up to 75 p.s.i.

*** LIMITED TO CURRENT INVENTORY. REPLACED BY AA126 SERIES***

2" POLYPROPYLENE STRAINER



	FIMCO Code #	MFG Part #	Description	List Price
Complete Strainers	5116206	LS200-20	2" x 2" Line Strainer w/20 Mesh Screen	\$ 85.59
	5116207	LS200-50	2" x 2" Line Strainer w/50 Mesh Screen	\$ 85.59
	5116208	LS200-80	2" x 2" Line Strainer w/80 Mesh Screen	\$ 85.59
	5116209	LS220	20 mesh screen only	\$ 48.14
Screens	5116210	LS250	50 mesh screen only	\$ 48.14
	5116211	LS280	80 mesh screen only	\$ 48.14
Gaskets	5072295	LS200-G	Gasket	\$ 4.10

- Precision molded construction
- Corrosion resistant
- Light weight
- Fiberglass reinforced
- Easy grip end cap
- Stainless steel screen
- EPDM gasket
- Heavy duty end cap threads



PRO SERIES SPRAYERS
UTV SPRAYERS
SPOT SPRAYERS
ATV SPRAYERS
TRAILER SPRAYERS
UTILITY & 3PT SPRAYERS
SKID SPRAYERS & BOOMS
PUMPS
SPRAYER ACCESSORIES
DRY MATERIAL SPREADERS
TRAILER CARTS & AERATORS
SPRAYER COMPONENTS
PARTSLIST BREAKDOWNS

LINE STRAINERS



- Made of corrosion resistant nylon.
- Easily installed into plumbing systems.
- Simply unscrew bowl for easy cleaning.

NYLON LINE STRAINER 3/4" & 1"

	FIMCO Code #	Description	List Price
Complete Strainers	5116179	3/4" Nylon Strainer w/40 mesh screen	\$ 20.73
	5116322	3/4" Short Bowl Nylon Strainer/40 Mesh Screen	\$ 13.89
	5116182	1" Nylon Strainer w/40 mesh screen	\$ 20.73
Gaskets	5072228	Viton gasket	\$ 5.78
	5072229	EPDM gasket	\$ 5.49
Screens	5116180	40 mesh screen only	\$ 5.11
	5116323	40 mesh screen only For Short Bowl Strainer	\$ 4.74
	5116181	80 mesh screen only	\$ 5.11
Bowls	5046089	Cap for 1" strainer	\$ 9.65
Caps	5058075	Bowl for 3/4" & 1" strainer	\$ 11.71

HYPRO®

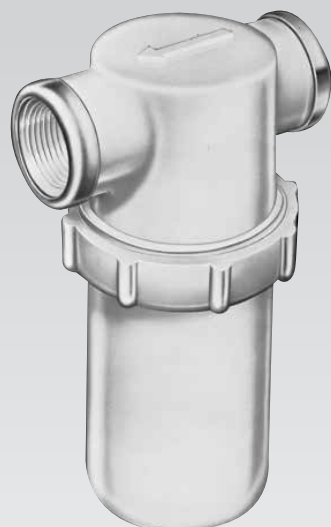

150 P.S.I. Maximum

NYLON LINE STRAINERS 1/2" - 3/4" - 1" - 1-1/4"

	FIMCO Code #	MFG Part #	Description	List Price
Complete Strainers	5117129	3350-0046	1/2" Strainer w/50 mesh screen	\$ 20.84
	5117130	3350-0043	1/2" Strainer w/80 mesh screen	\$ 23.80
	5116136	3350-0034	3/4" Strainer w/50 mesh screen	\$ 21.37
	5116141	3350-0035	3/4" Strainer w/80 mesh screen	\$ 24.08
	5116161	3350-0057	1" Strainer w/20 mesh screen	\$ 31.50
	5116162	3350-0058	1" Strainer w/50 mesh screen	\$ 31.50
	5116163	3350-0059	1" Strainer w/80 mesh screen	\$ 38.00
	5116243	3350-0071	1 1/4" Strainer w/20 mesh screen	\$ 38.00
	5116244	3350-0072	1 1/4" Strainer w/50 mesh screen	\$ 38.00
	5116245	3350-0073	1 1/4" Strainer w/80 mesh screen	\$ 42.75
Gaskets	5072149	1700-0044	Buna-N Gasket for 1/2" & 3/4" Strainer	\$ 1.04
	5072194	1700-0045	Viton gasket for 1/2" & 3/4" Strainer	\$ 7.83
	5072218	1700-0057	Buna-N Gasket for 1" & 1 1/4" Strainer	\$ 1.45
	5072219	1700-0058	Viton Gasket for 1" Strainer	\$ 10.37
Screens	5116131	3800-0025	50/mesh screen for 1/2" & 3/4" Strainer	\$ 7.22
	5116132	3800-0026	80/mesh screen for 1/2" & 3/4" Strainer	\$ 11.59
	5116165	3800-0040	20/mesh screen for 1" Strainer	\$ 10.69
	5116166	3800-0041	50/mesh screen for 1" Strainer	\$ 10.69
	5116167	3800-0042	80/mesh screen for 1" Strainer	\$ 17.98
	5116227	3800-0043	20/mesh screen for 1 1/4" Strainer	\$ 10.69
	5116228	3800-0044	50/mesh screen for 1 1/4" Strainer	\$ 10.69
Bowls	5116229	3800-0045	80/mesh screen for 1 1/4" Strainer	\$ 20.34
	5058035	3351-0005	Strainer bowl for 1/2" & 3/4" Strainer	\$ 7.12
	5058065	3351-0013	Strainer bowl for 1" & 1 1/4" Strainer	\$ 15.54
Caps	5046073	3351-0007	Strainer cap for 1/2" Strainer	\$ 9.68
	5046055	3351-0006	Strainer cap for 3/4" Strainer	\$ 12.11
	5046081	3351-0014	Strainer cap for 1" Strainer	\$ 20.54
	5046114	3351-0016	Strainer cap for 1 1/4" Strainer	\$ 24.49

HYPRO®



- Economically priced
- Reinforcing ring for durability
- Non-sticking, heavy-duty threads
- Corrosion resistant for use with most chemicals
- 125 P.S.I. Maximum

POLYPROPYLENE STRAINER 3/4" - 1" - 1-1/4" - 1-1/2"

	FIMCO Code #	MFG Part #	Description	List Price
Complete Strainers	5116213	3350-0034A	3/4" Strainer w/50 mesh screen	\$ 18.67
	5116214	3350-0035A	3/4" Strainer w/80 mesh screen	\$ 20.02
	5116215	3350-0058A	1" Strainer w/50 mesh screen	\$ 25.43
	5116216	3350-0059A	1" Strainer w/80 mesh screen	\$ 28.41
	5116217	3350-0072A	1 1/4" Strainer w/50 mesh screen	\$ 28.41
	5116218	3350-0073A	1 1/4" Strainer w/80 mesh screen	\$ 36.25
	5116219	3350-0113A	1 1/2" Strainer w/50 mesh screen	\$ 30.75
	5116220	3350-0114A	1 1/2" Strainer w/80 mesh screen	\$ 37.00
Gaskets	5072299	1700-0091	EPDM Gkt. for 3/4" Str.	\$ 1.45
	5072298	1700-0092	EPDM Gkt. for 1", 1 1/4", 1 1/2" Str.	\$ 1.82
Screens	5116246	3800-0029	3/4" screen - 20 mesh	\$ 8.55
	5116131	3800-0025	3/4" screen - 50 mesh	\$ 7.22
	5116132	3800-0026	3/4" screen - 80 mesh	\$ 11.59
	5116165	3800-0040	1" screen - 20 mesh	\$ 10.69
	5116166	3800-0041	1" screen - 50 mesh	\$ 10.69
	5116167	3800-0042	1" screen - 80 mesh	\$ 17.98
	5116227	3800-0043	1 1/4" screen - 20 mesh	\$ 10.69
	5116228	3800-0044	1 1/4" screen - 50 mesh	\$ 10.69
	5116229	3800-0045	1 1/4" screen - 80 mesh	\$ 20.34
	5116230	3800-0065	1 1/2" screen - 20 mesh	\$ 17.73
	5116231	3800-0066	1 1/2" screen - 50 mesh	\$ 15.65
5116232	3800-0067	1 1/2" screen - 80 mesh	\$ 25.28	

744A SPRAYER CONTROL KITS

FEATURES:

- Manual spray controller in a compact package
- Choice of liquid filled 100 PSI (7 bar) or 300 PSI (20 bar) gauge.
- Lighted pressure gauge for night use
- Heavy-duty switches with LED indicators
- Available in a variety of kit forms using solenoid or ball type control valves
- DirectoValve shutoff ball valves are ordered separately



144A-1 Solenoid Shutoff Valve

HOW TO ORDER

744A - 100 - L - 3
 Controller Model Gauge Scale Gauge Type Boom Sections
 744A 100 PSI/7bar L (Liquid) 1,3 or 5
 300 PSI/21 bar

MFG Part #	FIMCO Code #	Control Kit #	Description	List Price
90-50161	5273404	AAK744A-100L-30S	744A-100L-3 Sprayer Control Unit (Liquid Valve) 244C-3/4 Pressure Reg. Valve	\$ 571.52
90-50163	5275144	AAK744A-100L-33S	744A-100L-3 Sprayer Control Unit (Liquid Valve) 244C-3/4 Pressure Reg. Valve 144A DirectoValve Boom Section Valves	\$ 916.19
90-50149	5273446	744A-100L-3	744A-100L-3 Sprayer Control Unit	\$ 483.07

244 - 3/4 REMOTE CONTROL ELECTRIC REGULATING VALVE

MFG Part #	FIMCO Code #	Description	List Price
35-50049	5273448	Remote Control Electric - Regulating Value	\$ 177.65



The 244C-3/4 butterfly valve provides remote pressure control. Features two-wire lead for use in 12VDC system, reduced pressure loss (5 psi for 45 G.P.M. flow), and maximum operating pressure of 100 P.S.I. 3/4" NPT (F) connections. Two gallon per minute by-pass at 10 p.s.i. and four gallon per minute by-pass at 40 p.s.i. when the valve is fully closed. Low current draw (0.15 amp).

VALVES

DIRECTO VALVE CONTROL VALVE - MANUALLY OPERATED

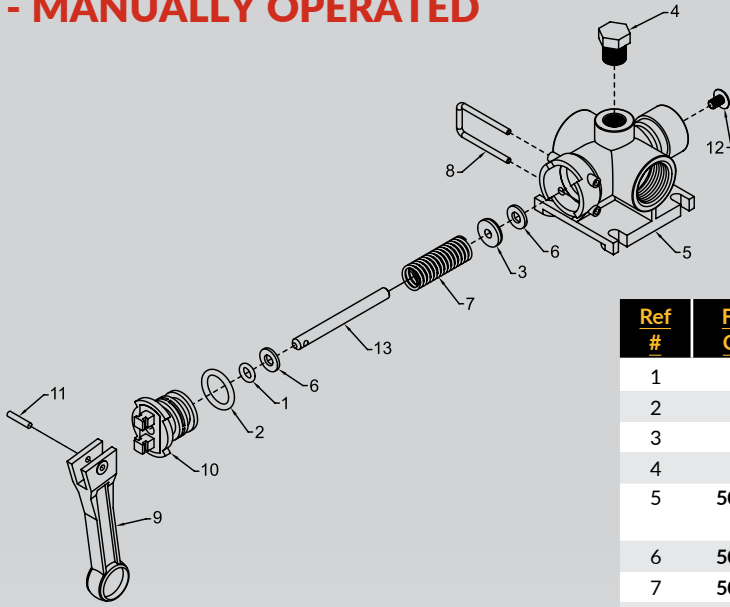

- Corrosion Resistant Materials: Wetted Parts Polypropylene, 316SS and Polyethylene.
- Maximum Pressure - 150 P.S.I.
- Large Capacity - 12.5 G.P.M. @ 5 P.S.I. Pressure Drop.
- 3/4" NPT(F) Inlet Connection.
- 1/2" NPT(F) Spray Line Connection.
- 3/4" NPT(F) Continuous By-Pass Connection.
- Valves May Be Connected w/close Nipples for Multiple Section Spray Control.



FIMCO Code #	MFG Part #	Description	List Price
5143316	AA6B	Control Valve	\$ 58.43
5168718	PK-AB6B-KIT	Repair Kit (Marked **)	\$ 24.52

Ref #	FIMCO Code #	Qty	MFG Part #	Description	List Price
1	**	1	CP7717-2/108-VI	O-Ring, Viton	\$ 5.79
2	**	1	CP7717-2/209-VI	O-Ring, Viton	\$ 5.69
3	**	1	CP38726-VI	Shut-Off Washer, Viton	\$ 8.23
4	--	1	--	Pipe Plug, 1/4" MNPT	
5	5002476	1	CP36303-PP	Poly Body (Black) for Valve Model No. AA6B	\$ 18.88
6	5016280	2	CP36307-PPB	Washer	\$ 2.12
7	5019230	1	CP36306-302SS	Spring	\$ 3.81
8	5053091	1	CP36309-302SS	Retaining Clip	\$ 3.68
9	5078178	1	CP-36301-NY	Handle, Nylon (Gray)	\$ 6.44
10	5086043	1	CP36302-PP	Poly Body Insert, (Black)	\$ 5.79
11	5101220	1	CP36308-SS	Groove Pin	\$ 1.45
12	5117281	1	CP38725-SS	#10-24 x 5/16" Phillips Truss Head Machine Screw	\$ 2.21
13	5132071	1	CP36304-SS	Stem	\$ 6.86

DIRECTO VALVE ELECTRONICALLY OPERATED VALVE

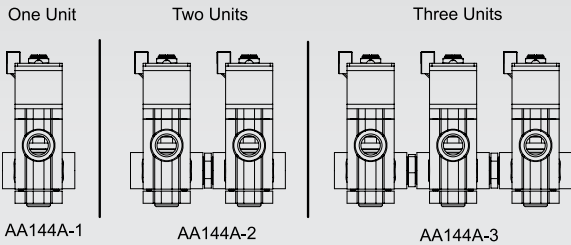

FIMCO Code #	MFG Part #	Description	List Price
5143319	AA144A-1	1 Unit Valve	\$ 177.66
5143320	AA144A-2	2 Unit Valve	\$ 359.91
5143321	AA144A-3	3 Unit Valve	\$ 542.18

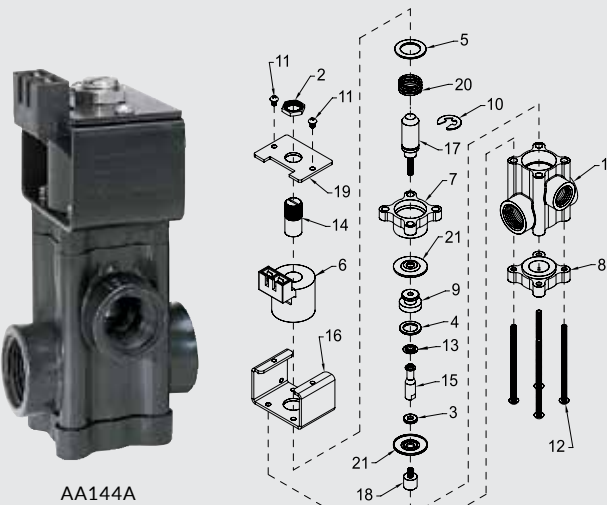

Ref #	FIMCO Code #	MFG Part #	Description	List Price
1	5002348	CP14801-PP	Body	\$ 16.87
2	5006279	CP15168-IENP	Jam Nut	\$ 5.52
3	5016143	CP14806-SS	Washer	\$ 6.27
*4	5016144	CP14802-EPR	Seat Washer	\$ 6.44
5	5016268	CP15169-SS	Washer	\$ 2.30
6	5054007	CP15163-NYB	Coil Assm, Nylon Encapsulated	\$ 58.82
7	5084087	CP15164-NYB	Upper Diaphragm Housing	\$ 6.21
8	5084088	CP15165-NYB	Lower Diaphragm Housing	\$ 23.15
9	5108037	CP14807-SS	Seat Washer Retainer	\$ 19.00
10	5108100	CP14813-1-IENP	Retaining Ring	\$ 2.30
11	5117134	CP14933-SS	#8-32 x 1/4" Round Head	\$ 1.78
12	5117135	CP14819-SS	#10-24 x 3 3/8" Round Head	\$ 2.10
13	5127048	CP14811-SS	Spacer	\$ 5.47
14	5131059	CP15161-IENP	Armature Stop	\$ 12.73
15	5132037	CP14812-SS	Stem	\$ 21.49
16	5133081	CP14927-3-I	Strap, Steel-Nitrotec Finish	\$ 9.70
17	5154046	CP15170-IENP	Armature	\$ 23.48
18	5154047	CP15162-SS	Lower Diaphragm Piston	\$ 11.95
19	CP15166-I	Coil Cover, Steel-Nitrotec Finish	\$ 5.22	
*20	CP15167-302SS	Spring	\$ 5.22	
*21	CP36101-EPR	Diaphragm	\$ 8.33	
*	5168755	PK-AB144A-1-KIT		\$ 31.91
*	5168756	PK-AB144A-1-VI-KIT		\$ 47.73

Designed for remote "on-off" control of spray booms and nozzles from operator's location. Operates on a 12 Volt DC system (2 Amp Current Draw). For pressures to 100 P.S.I.

*= Available in Spare Parts Kit

NO. 17 SELECTOR TEE VALVE



Spraying Systems Co.[®]

Choice of 7 Indexed Spray Boom Settings

Side Connection for by-pass and pressure relief valve

FIMCO Code #	MFG Part #	Description	List Price
5143295	AA17-L	3/4" FNPT Boom & 3/4" Valve & Gun Outlets	\$ 148.40
5143298	AA17-Y	3/4" FNPT Boom & 1" & 3/4" Valve & Gun Outlets	\$ 148.40

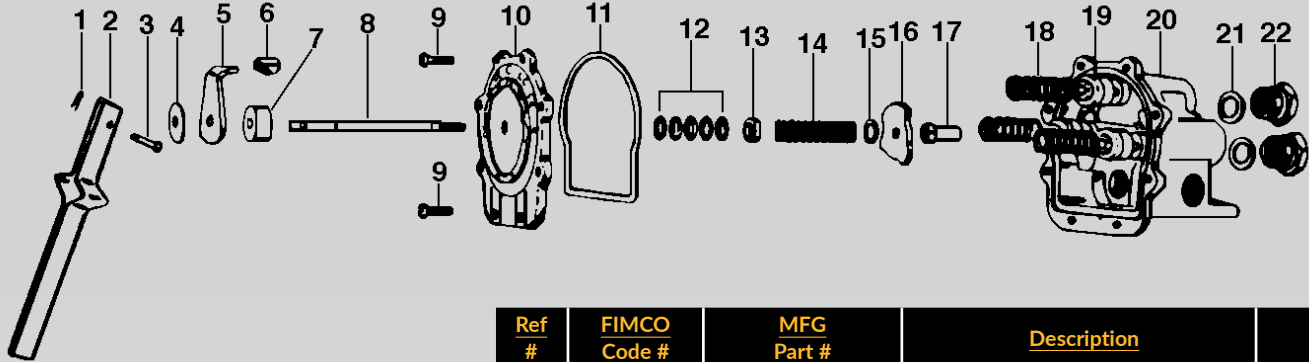

Side Connection for spray gun

Connection	Model #
Inlet Conn, 3/4" NPT	17L
Inlet Conn. 1" NPT	17Y
Boom Outlets (3)	3/4" NPT
GunJet Outlet	
Accessory Outlets	3/4" NPT

TeeValve remains shut off during selection of setting,

Lever is raised to open valve in indexed setting is lowered to close valve without changing index position. Gives fast positive "on-off" operation at ends of crop rows.

Ref #	FIMCO Code #	MFG Part #	Description	List Price
*1	Available In Kit Only		1/16" x 1/2" SS Cotter Pin	
2	5078065	CP6849-1-IZP	Handle	\$ 10.50
*3	Available In Kit Only		Rivet	
*4	Available In Kit Only		Handle Washer	
5	5120011	CP12128-IZP	Selector Shield	\$ 6.94
*6	Available In Kit Only		Selector Shield Tip, Celcon	
7	5127032	CP12129-CE	Spacer, Celcon	\$ 6.19
8	5132010	CP6972-SS	Main Stem, stainless steel	\$ 12.06
*9	Available In Kit Only		Hex Head Screw, 1/4-20 x 3/4"	
10	5017090	CP12126-AL	CoverPlate, Alum.	\$ 57.93
*11	Available In Kit Only		Gasket, Buna N	
*12	Available In Kit Only		Packing, Thermo Leather, (5 Reqd)	
13	5097032	CP12130-SS	Packing Gland, Stainless Steel	\$ 8.87
14	5019059	CP7254-SS	Main Spring, Stainless Steel	\$ 4.33
15	5016062	CP7987-SS	Washer, Stainles Steel	\$ 1.73
16	5045008	CP6971-AL	Selector Cam, Alum	\$ 4.88
17	5006068	CP6973-SS	Guide Nut	\$ 6.07
18	5019057	CP6959-SS	Spring, Stainless steel (3 Reqd)	\$ 3.75
19	5132021	CP6956-CE	Valve Stem, Celcon (3 Reqd.)	\$ 4.62
20	5002253	CP6934-3/4-AL	Body, Aluminum	\$ 67.48
*21	Available In Kit Only		Seat Plate, Poly (3 Reqd.)	
22	5005095	CP7902-AL	Outlet Adapter (3 Reqd.)	\$ 11.25
23	5005259	CP50116-AL	Inlet Adapter 1" M x 3/4"F (for17L)	\$ 12.90
5168135	PK-AB17-KIT		Repair Parts Kit Items Marked*	\$ 41.19

TEEJET VARI-SPACING NOZZLES

- For use with all interchangeable Spray Tips
- For operating pressures up to 125 p.s.i.

TeeJet Vari-Spacing Nozzles permit the construction of spray booms with adjustable nozzle spacing. Pipe, round tubing or square tubing is used to support the nozzles and nozzles are hose connected for liquid flow. A complete TeeJet Vari-Spacing Nozzle consists of clamp, lock nut, TeeJet Vari-Spacing body, TeeJet cap, internal strainer and Spray Tip of your choice TeeJet,

FloodJet or ConeJet. Nozzle bodies are made in a selection of materials brass, nylon and Celcon, with clamps made of heavy duty zinc-plated steel for rigid mounting. Choice of clamp sizes to fit 1/2", 3/4", 1" and 1-1/4" pipe or equivalent size tubing and 1", 1-1/4", & 1-1/2" Square tubing.



FIMCO Code #	MFG Part #	Description	List Price
5056094	3NTL38	Poly L Connector less cap & tip, fits 3/8" hose	\$ 1.74
5056024	NTL38	Nylon L Connector less cap & tip, fits 3/8" hose	\$ 1.88
5056095	3NTL12	Poly L Connector less cap & tip, fits 1/2" hose	\$ 1.74
5056023	NTL12	Nylon L Connector less cap & tip, fits 1/2" hose	\$ 1.88
5056096	3NTL58	Poly L Connector less cap & tip, fits 5/8" hose	\$ 2.21
5056061	NTL58	Nylon L Connector less cap & tip, fits 5/8" hose	\$ 2.30
5056097	3NTL34	Poly L Connector less cap & tip, fits 3/4" hose	\$ 2.42
5056057	NTL34	Nylon L Connector less cap & tip, fits 3/4" hose	\$ 2.12
5056014	6471B-400TD	Brass L Connector less cap & tip, fits 3/8" hose	\$ 14.39
5056007	9191B-531TD	Brass L Connector less cap & tip, fits 1/2" hose	\$ 14.39



FIMCO Code #	MFG Part #	Description	List Price
5056098	3NTT38	Poly T Connector less cap & tip, Fits 3/8" hose	\$ 1.97
5056028	NTT38	Nylon T Connector less cap & tip, fits 3/8" hose	\$ 1.92
5056099	3NTT12	Poly T Connector less cap & tip, fits 1/2" hose	\$ 1.97
5056027	NTT12	Nylon T Connector less cap & tip, fits 1/2" hose	\$ 1.97
5056100	3NTT58	Poly T Connector less cap & tip, fits 5/8" hose	\$ 3.06
5056062	NTT58	Nylon T Connector less cap & tip, fits 5/8" hose	\$ 2.42
5056101	3NTT34	Poly T Connector less cap & tip, fits 3/4" hose	\$ 2.57
5056056	NTT34	Nylon T Connector less cap & tip, fits 3/4" hose	\$ 3.05
5056015	6472B-400TD	Brass T Connector less cap & tip, fits 3/8" hose	\$ 14.39
5056008	9192B-531TD	Brass T Connector less cap & tip, fits 1/2" hose	\$ 14.39



FIMCO Code #	MFG Part #	Description	List Price
5272127	T-38C	Nylon Cross Connector less cap & tip, fits 3/8" hose	\$ 4.22
5271920	T-12C	Nylon Cross Connector less cap & tip, fits 1/2" hose	\$ 4.31

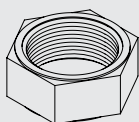

FIMCO Code #	MFG Part #	Description	List Price
5006087	CP5609	Brass lock nut	\$ 2.95
5006184	B-12	Nylon lock nut	\$ 0.39

VARI-SPACING NOZZLES & DIAPHRAGM CHECK VALVES



FIMCO Code #	MFG Part #	Description	List Price
5271963	AA111-1/2	Upper & Lower Clamp & Screw	\$ 5.19
5271964	AA111-3/4	Upper & Lower Clamp & Screw	\$ 5.19
5271965	AA111-1	Upper & Lower Clamp & Screw	\$ 5.19
5272510	AA111-1 1/4	Upper & Lower Clamp & Screw	\$ 8.68



FIMCO Code #	MFG Part #	Description	List Price
5271966	AA111SQ-1	Upper & Lower Clamp & Screw	\$ 5.96
5271933	AA111SQ-1-1/4	Upper & Lower Clamp & Screw	\$ 8.97
5272511	AA111SQ-1-1/2	Upper & Lower Clamp & Screw	\$ 10.66

DIAPHRAGM CHECK VALVES



TYPE 8360

Made of Nylon with Celcon / polypropylene end cap assembly. Check valve opens at 10 P.S.I. pressure. 1/4" NPT(M) inlet connection. For flow rates up to 2 G.P.M. Overall length 2". Weight 1 ounce.

FIMCO Code #	MFG Part #	Description	List Price
5138473	8360-NYB	Check Valve Less Cap, Tip & Strainer	\$ 18.81
5005137	4676-NYB-1/4	1/4" Nylon Adapter	\$ 2.63



TYPE 13430

Nylon with polypropylene retainer ring. Single, double or triple hose connection for 3/8" or 1/2" hose I.D. For flow rates to 3 G.P.M.

FIMCO Code #	MFG Part #	Description	List Price
5056054	13430-1L-406-NYB	L Valve, fits 3/8 I.D. Hose	\$ 24.30
5056060	13430-1R-406-NYB	L Valve, fits 3/8 I.D. Hose	\$ 24.30
5056053	13430-1L-540-NYB	L Valve, fits 1/2 I.D. Hose	\$ 24.30
5056049	13430-1R-540-NYB	L Valve, fits 1/2 I.D. Hose	\$ 24.30
5056055	13430-2-406-NYB	T Valve, fits 3/8 I.D. Hose	\$ 24.30
5056048	13430-2-540-NYB	T Valve, fits 1/2 I.D. Hose	\$ 24.30
5056077	13430-3-406-NYB	Cross Valve, fits 3/8 I.D. Hose	\$ 24.30
5056078	13430-3-540-NYB	Cross Valve, fits 1/2 I.D. Hose	\$ 24.30

REPAIR PARTS FOR DIAPHRAGM CHECK VALVES



4620 Diaphragm

FIMCO Code #	MFG Part #	Description	List Price
5063083	CP4620-FA	Diaphragm, Fairprene	\$ 0.53
5063084	CP4620-VI	Diaphragm, Viton	\$ 1.73
5046113	21950-10-NYB	Chemsaver End-Cap	\$ 4.13
5063132	CP21953-EPR	Diaphragm, EPDM rubber w/Nipples	\$ 0.53
5063133	CP21953-VI	Diaphragm, Viton w/Nipples	\$ 1.68

SPRAY NOZZLE PARTS

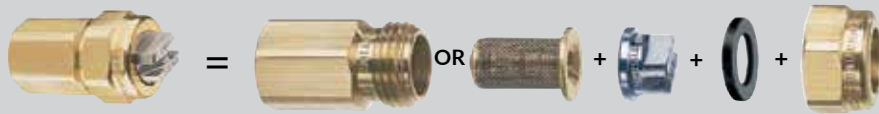

NOZZLE BODIES

Spray Nozzle Type T or TT Nozzle Body 5053 Strainer Spray Tip Optional Tip Gasket CP1325 TeeJet Cap



FIMCO Code #	MFG Part #	Description	List Price
5002298	CP1336	1/8 TT Male Brass Body	\$ 2.57
5002294	CP1322	1/4 TT Male Brass Body	\$ 2.57
5002296	CP8028-NYB	1/4 TT Male Nylon Body	\$ 1.84



FIMCO Code #	MFG Part #	Description	List Price
5002306	CP1335	1/8 T Female Brass Body	\$ 2.57
5002302	CP1321	1/4 T Female Brass Body	\$ 2.57
5002304	CP12094-NYB	1/4 T Female Nylon Body	\$ 1.78



FIMCO Code #	MFG Part #	Description	List Price
5046022	CP1325	Brass Nozzle Cap	\$ 1.56
5046118	CP20230	Brass, For Use With Ceramic Discs and Cores	\$ 1.86
5046052	8027	White Nylon Nozzle Cap	\$ 0.39
5046126	38027	Black Poly Nozzle Cap	\$ 0.42



FIMCO Code #	MFG Part #	Description	List Price
5046100	CP18032A-NYB	Winged Teejet Nylon Cap	\$ 1.45



FIMCO Code #	MFG Part #	Description	List Price
5005074	4676-1/4	1/4" Brass Adapter (Same thread as nozzle cap)	\$ 3.21
5005137	4676-NYB-1/4	1/4" Nylon Adapter (Same thread as nozzle cap)	\$ 2.63



FIMCO Code #	MFG Part #	Description	List Price
5116046	5053-50-SS	Brass Screen Assy w/50 Mesh SS Screen	\$ 3.25
5116047	5053-100-SS	Brass Screen Assy w/100 Mesh SS Screen	\$ 3.25
5116033	CP2930-50-SS	50 Mesh Stainless Steel Screen Only for 5053	\$ 1.09
5116032	CP2930-100-SS	100 Mesh Stainless Steel Screen Only for 5053	\$ 1.09
5116019	8079-PP-50	Polypropylene Screen Assy w/50 Mesh SS Screen	\$ 1.37
5116020	8079-PP-100	Polypropylene Screen Assy w/100 Mesh SS Screen	\$ 1.37



FIMCO Code #	MFG Part #	Description	List Price
5116112	4514-10	Brass Slotted Strainer 50/Mesh	\$ 1.53
5116118	4514-NY-10	Nylon Slotted Strainer 50/Mesh	\$ 1.45



FIMCO Code #	MFG Part #	Description	List Price
5116038	4067-SS-50	Stainless Steel Cup Strainer 50/Mesh	\$ 1.78
5116039	4067-SS-100	Stainless Steel Cup Strainer 100/Mesh	\$ 1.78



FIMCO Code #	MFG Part #	Description	List Price
5116040	4193A-5-50SS	Brass Check Valve & Strainer Assy w/50 Mesh Screen	\$ 5.70
5116041	4193A-5-100SS	Brass Check Valve & Strainer Assy w/100 Mesh Screen	\$ 5.70
5116160	4193A-PP-5-50SS	Poly Check Valve & Strainer Assy w/50 Mesh Screen	\$ 4.52
5116164	4193A-PP-5-100SS	Poly Check Valve & Strainer Assy w/100 Mesh Screen	\$ 4.52



FIMCO Code #	MFG Part #	Description	List Price
5143085	11750 -10	Brass Check Valve for Large Capacity Nozzles	\$ 7.52
5143187	11750-PP-5	Polypropylene Check Valve for large capacity nozzles	\$ 6.40

SPLIT-EYELET & SWIVEL SPRAY NOZZLES



<u>FIMCO Code #</u>	<u>MFG Part #</u>	<u>Description</u>	<u>List Price</u>
5056042	7421-3/4 T-NYB	Male Split Eyelet Connector, nylon body-fits 3/4" pipe	\$ 4.45
5056043	7421-1/2 T-NYB	Male Split Eyelet Connector, nylon body-fits 1/2" pipe	\$ 4.45



<u>FIMCO Code #</u>	<u>MFG Part #</u>	<u>Description</u>	<u>List Price</u>
5056044	7421-3/4 TD	Split Eyelet Nozzle-for Angle Iron Boom-fits 3/4" pipe	\$ 11.27
5056045	7421-1/2 TD	Split Eyelet Nozzle-for Angle Iron Boom-fits 1/2" pipe	\$ 10.44



<u>FIMCO Code #</u>	<u>MFG Part #</u>	<u>Description</u>	<u>List Price</u>
5005073	4676-1/8 Brass	Brass Adapter, same thread as Nozzle Cap - Replaces Nozzle Cap to provide 1/8" outlet	\$ 3.21
5005074	4676-1/4 Brass	Brass Adapter, same thread as Nozzle Cap - Replaces Nozzle Cap to provide 1/4" outlet	\$ 3.21
5005137	4676- NYB-1/4	Nylon Adapter, same thread as Nozzle Cap - Replaces Nozzle Cap to provide 1/4" outlet	\$ 2.63



<u>FIMCO Code #</u>	<u>MFG Part #</u>	<u>Description</u>	<u>List Price</u>
5002382	5000-1/4T	Body assy for Swivel, less tip, cap & strainer, brass	\$ 20.25



<u>FIMCO Code #</u>	<u>MFG Part #</u>	<u>Description</u>	<u>List Price</u>
5002383	5540-1/4TT	Body assy for Swivel, less tip, cap & strainer, brass	\$ 22.38



<u>FIMCO Code #</u>	<u>MFG Part #</u>	<u>Description</u>	<u>List Price</u>
5002385	6240-1/4TT	Body assy for Swivel, less tip, cap & strainer, brass	\$ 21.92



<u>FIMCO Code #</u>	<u>MFG Part #</u>	<u>Description</u>	<u>List Price</u>
5002386	7450-2T	Body assy for Swivel, less tip, cap & strainer, brass	\$ 36.94



<u>FIMCO Code #</u>	<u>MFG Part #</u>	<u>Description</u>	<u>List Price</u>
5143201	20900-1/4MXT	1/4M Brass Valve & Nozzle Body	\$ 66.20
5143202	20900-1/4FXT	1/4F Brass Valve & Nozzle Body	\$ 66.20

A compact quarter turn "On-Off " ball valve used with interchangeable spray tips. Brass construction. Maximum operating pressure - 400 P.S.I.

"QUICKJET" NOZZLE ASSEMBLY SYSTEM

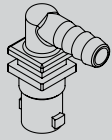

FIMCO Code #	MFG Part #	Description	List Price
5056065	18638-111-540-NYB	Single 1/2" Hose Shank Quick Teejet Nozzle Body	\$ 4.58
5056066	18719-111-785-NYB	Single 3/4" Hose Shank Quick Teejet Nozzle Body	\$ 4.58



FIMCO Code #	MFG Part #	Description	List Price
5056067	18639-112-540-NYB	Double 1/2" Hose Shank Quick Teejet Nozzle Body	\$ 4.58
5056068	18720-112-785-NYB	Double 3/4" Hose Shank Quick Teejet Nozzle Body	\$ 4.58

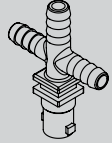

FIMCO Code #	MFG Part #	Description	List Price
5056069	18640-113-540-NYB	Triple 1/2" Hose Shank Quick Teejet Nozzle Body	\$ 4.58
5056070	18721-113-785-NYB	Triple 3/4" Hose Shank Quick Teejet Nozzle Body	\$ 4.58

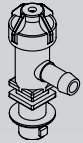

FIMCO Code #	MFG Part #	Description	List Price
5056086	22251-311-500-NYB	Single 1/2" Hose Shank w/Diaphragm Check Valve	\$ 9.39
5056087	22251-311-750-NYB	Single 3/4" Hose Shank w/Diaphragm Check Valve	\$ 9.39



FIMCO Code #	MFG Part #	Description	List Price
5056089	22252-312-500-NYB	Double 1/2" Hose Shank w/Diaphragm Check Valve	\$ 9.39
5056090	22252-312-750-NYB	Double 3/4" Hose Shank w/Diaphragm Check Valve	\$ 9.39

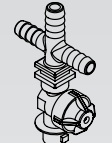

FIMCO Code #	MFG Part #	Description	List Price
5056075	19351-213-540-NYB	Triple 1/2" Hose Shank w/Diaphragm Check Valve	\$ 11.36
5056076	19351-213-785-NYB	Triple 3/4" Hose Shank w/Diaphragm Check Valve	\$ 11.36



FIMCO Code #	MFG Part #	Description	List Price
5272162	QJ111-3/4	Quick Teejet Clamp Sub Assy for 3/4" Pipe	\$ 3.02
5272163	QJ111-1	Quick Teejet Clamp Sub Assy for 1" Pipe	\$ 3.02

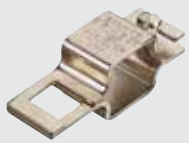

FIMCO Code #	MFG Part #	Description	List Price
5272164	QJ111SQ-1	Quick Teejet Clamp Sub Assy for 1" Sq Tube	\$ 3.02
5272165	QJ111SQ-1-1/4	Quick Teejet Clamp Sub Assy for 1 1/4" Sq Tube	\$ 3.02



FIMCO Code #	MFG Part #	Description	List Price
5002375	QJT-NYB	Quick Teejet Adapter w/ Gasket Fits Teejet Nozzle Bodies	\$ 5.83



FIMCO Code #	MFG Part #	Description	List Price
5072308	CP20266-EPDM	Gasket For QJT-NYB & QJT8360-NYB Adapter	\$ 2.10



FIMCO Code #	MFG Part #	Description	List Price
5002376	QJT8360-NYB	Same as QJT-NYB w/Diaphragm Check Valve	\$ 6.22



FIMCO Code #	MFG Part #	Description	List Price
5002380	QJ8360-NYB	Diaphragm Ck. Valve Quick Teejet Nozzle Body Assy.	\$ 5.72

"QUICKJET" NOZZLE ASSEMBLY SYSTEM

QUICK TEEJET CAPS

The Quick TeeJet Caps are designed with grooves that fit locating lugs on the nozzle body. Caps are made of Celcon and are available for use with all TeeJet spray tips.

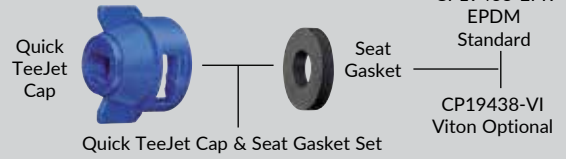

Quick TeeJet Caps	Quick TeeJet Cap Only		Quick TeeJet Cap & Seat Gasket Set		For Use With Spray Tips
	MFG Part #	List Price	MFG Part #	List Price	
	CP114440-*-CE	\$ 0.84	114441-*-CELR	\$ 1.18	TeeJet Flat Spray Tips (Smaller Capacities) TP Standard -0067 Thru -08 XR -01 Thru -08 DG -015 Thru -05 TT -01 Thru -05 AIXR -015 Thru -06
	CP25609-*-NY	\$ 0.97	25610-*-NYR	\$ 1.34	TeeJet Flat Spray Tips (Larger Capacities) TP Standard -10 Thru -20 XR -10 Thru -15
	CP114442-*-CE	\$ 0.97	114443-*-CELR	\$ 1.34	TJ TwinJet AI 015 Thru 08 No. TJ60...Spray Tip
	CP25599-*-NY	\$ 0.97	25600-*-NYR	\$ 1.34	TK-VS FloodJet Turbo FloodJet VisiFlo Spray Tip VisiFlo Spray Tip
	CP114444-*-CE	\$ 0.97	114445-*-CELR	\$ 1.34	TK FloodJet FL FullJet TX ConeJet TG Full Cone

Colors of Quick TeeJet Caps	Color Code	Colors of Quick TeeJet Caps	Color Code
Black	1	Green	5
White	2	Yellow	6
Red	3	Brown	7
Blue	4	Orange	8

* Specify color-code (see chart). Unless otherwise specified, a yellow (6) cap will be supplied.

** These Quick TeeJet caps available only in black.

How to order: For a cap and seat gasket set, specify set no. and color-code. Example: 25612-3-NYR

For cap only, specify part no. and color-code. Ex: CP25597-4-NY
For seat only, specify part no. Ex: CP19438-EPR



FIMCO Code #	MFG Part #	Description	List Price
5016157	CP19438-EPR	EPDM Seat & Gasket for cap (Standard)	\$ 0.57
5016158	CP19438-VI	VITON Seat & Gasket for cap (Optional)	\$ 2.40

XTENDER TIPS

Nozzle Size (MNPT)	Pressure (PSI)	Flow Rate (GPM)	Gallons per Acre at swath shown MPH								GAL/1000Ft ²				Swath (Ft) at 40 PSI 48 in high
			4	5	6	8	10	12	15	20	2	3	4	5	
10 (1/4")	30	0.9	8.9	7.1	5.9	4.5	3.6	3.0	2.4	1.8	0.41	0.27	0.20	0.16	13
	40	1.0	9.9	7.9	6.6	5.0	4.0	3.3	2.6	2.0	0.45	0.30	0.23	0.18	
	50	1.1	10.9	8.7	7.3	5.4	4.4	3.6	2.9	2.2	0.50	0.33	0.25	0.20	
15 (1/4")	30	1.3	10.9	8.7	7.3	5.4	4.4	3.6	2.9	2.2	0.55	0.36	0.27	0.22	14
	40	1.5	12.5	10.0	8.3	6.3	5.0	4.2	3.4	2.5	0.61	0.41	0.30	0.24	
	50	1.7	13.7	11.0	9.2	6.9	5.5	4.6	3.7	2.8	0.67	0.45	0.33	0.27	
20 (1/4")	30	1.7	13.6	10.9	9.0	6.8	5.4	4.5	3.6	2.7	0.62	0.42	0.31	0.25	15
	40	2.0	16.0	12.8	10.6	8.0	6.4	5.3	4.3	3.2	0.73	0.49	0.37	0.29	
	50	2.2	17.6	14.1	11.7	8.8	7.0	5.9	4.7	3.5	0.81	0.54	0.40	0.32	
24 (1/4")	30	2.1	16.2	13.0	10.8	8.1	6.5	5.4	4.3	3.2	0.75	0.50	0.37	0.30	16
	40	2.4	18.6	14.9	12.4	9.3	7.4	6.2	5.0	3.7	0.85	0.57	0.43	0.34	
	50	2.7	20.9	16.7	13.9	10.4	8.4	7.0	5.6	4.2	0.96	0.64	0.48	0.38	
43 (3/8")	30	3.7	31.6	25.3	21.1	15.8	12.6	10.5	8.4	6.3	1.45	0.97	0.72	0.58	14
	40	4.3	36.7	29.4	24.5	18.3	14.7	12.2	9.8	7.3	1.68	1.12	0.84	0.67	
	50	4.8	41.0	32.8	27.3	20.5	16.4	13.7	10.9	8.2	1.88	1.25	0.94	0.75	
80 (1/2")	30	6.9	68.3	54.6	45.5	34.2	27.3	22.8	18.2	13.7	3.14	2.09	1.57	1.25	13
	40	8.0	79.2	63.4	52.8	39.6	31.7	26.4	21.1	15.8	3.64	2.42	1.82	1.45	
	50	8.9	88.1	70.5	58.7	44.1	35.2	29.4	23.5	17.6	4.04	2.70	2.02	1.62	
167 (3/4")	30	9.8	97.0	77.6	64.7	48.5	38.8	32.3	25.9	19.4	4.45	2.97	2.23	1.78	15
	40	14.5	128	103	85.4	64.1	51.3	42.7	34.2	25.6	5.88	3.92	2.94	2.35	
	50	16.7	148	118	98.4	73.8	59.0	49.2	39.4	29.5	6.78	4.52	3.39	2.71	
215 (3/4")	30	18.7	165	132	110	82.6	66.1	55.1	44.1	33.1	7.59	5.06	3.79	3.03	16
	40	20.5	181	145	121	90.6	72.5	60.4	48.3	36.2	8.32	5.54	4.16	3.33	
	50	18.6	144	115	95.9	71.9	57.5	48.0	38.4	28.8	6.60	4.40	3.30	2.64	
215 (3/4")	30	21.5	166	133	111	83.1	66.5	55.4	44.3	33.3	7.63	5.09	3.82	3.05	16
	40	24.0	186	149	124	92.8	74.3	61.9	49.5	37.1	8.52	5.68	4.26	3.41	
	50	26.3	203	163	136	102	81.4	67.8	56.2	40.7	9.34	6.22	4.67	3.73	



Part #	Color	List Price
FC-XT010	GREEN	\$ 65.00
FC-XT020	BLUE	\$ 65.00
FC-XT024	YELLOW	\$ 65.00
FC-XT043	ORANGE	\$ 79.00

TEEJET SPRAY TIPS

PRO SERIES SPRAYERS
UTV SPRAYERS
SPOT SPRAYERS
ATV SPRAYERS
TRAILER SPRAYERS
UTILITY & 3PT SPRAYERS
SKID SPRAYERS & BOOMS
PUMPS
SPRAYER ACCESSORIES
DRY MATERIAL SPREADERS
TRAILER CARTS & AERATORS
SPRAYER COMPONENTS
PARTS/ST BREAKDOWNS

Type	Size Type	Orifice Insert Tip Material	Example Tip #	List Price
 XR TEEJET® EXTENDED RANGE (TAPERED FLAT SPRAY TIPS)	-01 and Larger	Stainless Steel/Celcon	XR8001VS	\$ 7.94
		Polymer (110° only)	XR11002-VP	\$ 3.57
		Ceramic (110° only)	XR11003-VK	\$ 6.14
 DG TEEJET® DRIFT GUARD (TAPERED FLAT SPRAY TIPS)	80° And 110°	With Polymer Pre-Orifice	DG11002-VP	\$ 6.55
	-01 Through -05	Stainless Steel/Celcon	DG8002VS	\$ 11.00
 TEEJET® SPRAY TIPS (TAPERED FLAT SPRAY TIPS)	-0050 Or Smaller	Brass	TP800050	\$ 4.77
	Larger Than -0050	Brass	TP800067	\$ 4.77
	Smaller Than -01	Stainless Steel	TP800067-SS	\$ 27.36
		Stainless Steel	TP8001-SS	\$ 12.23
	Hard Stainless Steel	TP8001-HSS	\$ 16.84	
	-01 And Larger	Stainless Steel/Celcon	TP8001VS	\$ 7.10
	.01 And Larger	Polymer	TP8002VP	\$ 1.01
 TEEJET® AIXR SPRAY TIPS (TAPERED FLAT SPRAY TIPS)	-01 And Larger	Polymer	AIXR110015VP	\$ 8.27
		Brass	TP8001E	\$ 4.85
 TEEJET® SPRAY TIPS (TAPERED FLAT SPRAY TIPS)	-01 And Larger	Stainless Steel	TP8001E-SS	\$ 12.45
		Hard. Stainless Steel	TP8001E-HSS	\$ 17.12
		Stainless Steel/Celcon	TP8001EVS	\$ 7.10
 TURBO TEEJET® SPRAY TIPS (WIDE ANGLE FLAT SPRAY)	-01 Thru -05	Polymer (110° Only)	TT11001-VP	\$ 7.49
		Brass	TK-3	\$ 7.82
 FLOODJET® SPRAY TIPS (WIDE ANGLE FLAT SPRAY)	All Sizes	Stainless Steel	TK-SS3	\$ 14.23
		Stainless Steel/Celcon	TK-VS3	\$ 13.54
		Stainless Steel/Celcon	TF-VS4	\$ 15.02
 TURBO FLOODJET® SPRAY TIPS (WIDE ANGLE FLAT SPRAY)	All Sizes	Polymer	TF-VP4	\$ 3.41
		Stainless Steel/Celcon	AI110015-VS	\$ 15.19
 AI TEEJET® SPRAY TIPS (TAPERED FLAT SPRAY)	-015 THRU -10	Brass	TX-1	\$ 6.70
		Brass (With Strainer)	TLX-1	\$ 10.14
		Stainless Steel	TX-SS1	\$ 42.04
		Stainless Steel	TX-VS4	\$ 7.50
		Ceramic	TX-VK4	\$ 6.78
 TX CONEJET® SPRAY TIPS (HOLLOW CONE SPRAY)	All Sizes	Stainless Steel	CP4916-49	\$ 3.57
		Brass	CP3942	\$ 0.51
		Aluminum	CP3942-AL	\$ 0.51
		Stainless Steel	CP3942-SS	\$ 0.77
 TEEJET® ORIFICE PLATES	All Sizes	Stainless Steel	CP4916-49	\$ 3.57
		Brass	CP3942	\$ 0.51
		Aluminum	CP3942-AL	\$ 0.51
 TEEJET® PLUG TIPS	All Sizes	Stainless Steel	CP3942-SS	\$ 0.77
		Aluminum	CP3942-AL	\$ 0.51

TEEJET SPRAY TIPS

VISIFLO COLOR CODED SPRAY TIPS

MFG Part #	Description	List Price
TP8001VS	Stainless Steel w/VisiFlo color-coding	\$ 7.10
TP110015VP	Polymer w/VisiFlo color-coding	\$ 1.01
TP11001-HSS	Hardened Stainless Steel	\$ 16.84
TP8001-SS	Stainless Steel	\$ 12.23
TP8001	Brass	\$ 4.77



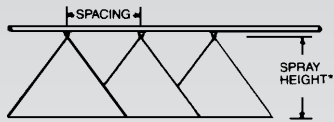

SUGGESTED MINIMUM SPRAY HEIGHT	
SPRAY ANGLE	SPRAY HEIGHT 20" SPACING
80°	17-19"
110°	10-12"



Adjust spray height in the field to overlap approximately 30% of each edge of pattern.

Tip Color VisiFlo Version	TIP NO. (STRAINER SCREEN SIZE)		Liquid Pressure in PSI	Capacity 1 Nozzle in GPM	Capacity 1 Nozzle in oz/min	GALLONS PER ACRE 20" SPACING				GALLONS PER ACRE 30" SPACING			
	80° Series	110° Series				5	6	7	8	5	6	7	8
	M.P.H.	M.P.H.				M.P.H.	M.P.H.	M.P.H.	M.P.H.	M.P.H.	M.P.H.		
ORANGE	8001 (100 Mesh)	11001 (100 Mesh)	30	.09	11	5.1	4.3	3.7	3.2	3.4	2.9	2.5	2.1
			35	.09	12	5.6	4.6	4.0	3.5	3.7	3.1	2.6	2.3
			40	.10	13	5.9	5.0	4.2	3.7	4.0	3.3	2.8	2.5
			45	.11	14	6.3	5.3	4.5	3.9	4.2	3.5	3.0	2.6
			60	.12	15	7.3	6.1	5.2	4.6	4.9	4.0	3.5	3.0
GREEN	80015 (100 Mesh)	110015 (100 Mesh)	30	.13	17	7.7	6.4	5.5	4.8	5.1	4.3	3.7	3.2
			35	.14	18	8.3	6.9	6.0	5.2	5.6	4.6	4.0	3.5
			40	.15	19	8.9	7.4	6.4	5.6	5.9	5.0	4.2	3.7
			45	.16	20	9.5	7.9	6.8	5.9	6.3	5.3	4.5	3.9
			60	.18	23	10.9	9.1	7.8	6.8	7.3	6.1	5.2	4.6
YELLOW	8002 (50 Mesh)	11002 (50 Mesh)	30	.17	22	10.3	8.6	7.4	6.4	6.9	5.7	4.9	4.3
			35	.19	24	11.1	9.3	7.9	6.9	7.4	6.2	5.3	4.6
			40	.20	26	11.9	9.9	8.5	7.4	7.9	6.6	5.7	5.0
			45	.21	27	12.6	10.5	9.0	7.9	8.4	7.0	6.0	5.3
			60	.25	32	14.6	12.1	10.4	9.1	9.7	8.1	6.9	6.1
BLUE	8003 (50 Mesh)	11003 (50 Mesh)	30	.26	33	15.4	12.9	11.0	9.7	10.3	8.6	7.4	6.4
			35	.28	36	16.7	13.9	11.9	10.4	11.1	9.3	7.9	6.9
			40	.30	38	17.8	14.9	12.7	11.1	11.9	9.9	8.5	7.4
			45	.32	41	18.9	15.8	13.5	11.8	12.6	10.5	9.0	7.9
			60	.37	47	22	18.2	15.6	13.6	14.6	12.1	10.4	9.1
RED	8004 (50 Mesh)	11004 (50 Mesh)	30	.35	45	21	17.2	14.7	12.9	13.7	11.4	9.8	8.6
			35	.37	47	22	18.5	15.9	13.9	14.8	12.3	10.6	9.3
			40	.40	51	24	19.8	17.0	14.9	15.8	13.2	11.3	9.9
			45	.42	54	25	21	18.0	15.8	16.8	14.0	12.0	10.5
			60	.49	63	29	24	21	18.2	19.4	16.2	13.9	12.1
BROWN	8005 (50 Mesh)	11005 (50 Mesh)	30	.43	55	26	21	18.4	16.1	17.2	14.3	12.3	10.7
			35	.47	60	28	23	19.8	17.4	18.5	15.4	13.2	11.6
			40	.50	64	30	25	21	18.6	19.8	16.5	14.1	12.4
			45	.53	68	32	26	23	19.7	21	17.5	15.0	13.1
			60	.61	78	36	30	26	23	24	20	17.3	15.2
GRAY	8006 (50 Mesh)	11006 (50 Mesh)	30	.52	67	31	26	22	19.3	21	17.2	14.7	12.9
			35	.56	72	33	28	24	21	22	18.5	15.9	13.9
			40	.60	77	36	30	25	22	24	19.8	17.0	14.9
			45	.64	82	38	32	27	24	25	21	18.0	15.8
			60	.74	95	44	36	31	27	29	24	21	18.2
WHITE	8008 (50 Mesh)	11008 (50 Mesh)	30	.69	88	41	34	29	26	27	23	19.6	17.2
			35	.75	96	44	37	32	28	30	25	21	18.5
			40	.80	102	48	40	34	30	32	26	23	19.8
			45	.85	109	50	42	36	32	34	28	24	21
			60	.98	125	58	49	42	36	39	32	28	24

TEEJET TIPS

Nozzles For Soybean Rust & Other Fungicide Applications	DENSITY OF CROP CANOPY			Droplet Sizes	Sizes Available	List Price
	Light	Medium	Heavy			
 TwinJet	EXCELLENT	EXCELLENT	EXCELLENT	VF ● M C	TJ60-11002VS THRU TJ60-11010VS	\$ 13.82 \$ 79.64
 XR TeeJet  XRC TeeJet	EXCELLENT	VERY GOOD	GOOD	VF ● M C VC	XR8001VS THRU 8008VS XR11001VS THRU XR1108 XRC80015-VS THRU 06 XRC110025-VS THRU 06	\$ 7.94 \$ 9.12
 Turbo TeeJet	EXCELLENT	VERY GOOD	GOOD	● M C VC XC	TT11001-VP THRU TT11008-VP	\$ 7.49
 Turbo TeeJet Duo	EXCELLENT	EXCELLENT	EXCELLENT	● M C VC XC	QJ90-2XTT11001-VP THRU QJ90-2XTT11008-VP	\$ 22.25

VF VERY FINE ● FINE M MEDIUM C COARSE VC VERY COARSE XC EXTREMELY COARSE

PRO SERIES SPRAYERS
UTV SPRAYERS
SPOT SPRAYERS
ATV SPRAYERS
TRAILER SPRAYERS
UTILITY & 3PT SPRAYERS
SKID SPRAYERS & BOOMS
PUMPS
SPRAYER ACCESSORIES
DRY MATERIAL SPREADERS
TRAILER CARTS & AERATORS
SPRAYER COMPONENTS
PARTS LIST BREAKDOWNS

TEEJET SPRAY TIPS

XR TeeJet® Extended Range Flat Spray Tips

Typical Applications:

General use tip that provides excellent coverage particularly when applying insecticides, fungicides or contact herbicides.

Features:

- Excellent spray distribution over a wide range of pressures—15–60 PSI (1–4 bar).
- Ideal for rigs equipped with sprayer controllers.
- Reduces drift at lower pressures, better coverage at higher pressures.
- Available in stainless steel, ceramic and polymer in 80° and 110° spray angles with VisiFlo® color-coding.
- Ceramic is available with corrosive-resistant polypropylene VisiFlo color-coded tip holder in 80° capacities 03–08 and 110° capacities 02–08.
- XR110025 only available in VK.
- XR80025 and XR80035 only available in VS.
- Brass available in 110° only.
- Automatic spray alignment with 114441-* -CELR Quick TeeJet® cap and gasket.
- Automatic spray alignment for sizes 10 and 15 with 25610-* -NYR Quick TeeJet cap and gasket.

Tip Size	List Price
XR8001VS thru XR8008VS	\$ 7.94
XR11001VS thru XR11008VS	\$ 7.94
For use with the 25612 TeeJet cap	
XRC80015-VS thru XRC8006-VS	\$ 9.12
XRC110025-VS thru XRC11005-VS	\$ 9.12
XR8010SS thru XR8015SS	\$ 9.43
XR11010SS thru XR11015SS	\$ 9.43
For use with the 25610 TeeJet cap	

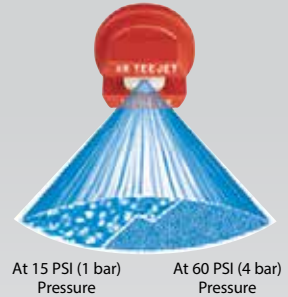

CONTACT PRODUCT	SYSTEMIC PRODUCT	DRIFT MANAGEMENT
EXCELLENT	GOOD	GOOD
GOOD*	VERY GOOD *	VERY GOOD *

*At pressures below 30 PSI (2.0 bar)

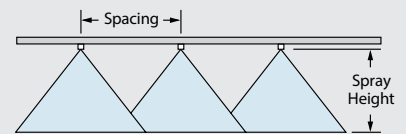

Optimum Spray Height

Spray Angle	Optimum Spray Height
80°	30"
110°	20"

Tip Size	PSI	DROPSIZE	CAPACITY ONE NOZZLE IN GPM	CAPACITY IN OZ./MIN.	GPA										GALLONS PER 1000 SQ. FT.			
					20°													
					4 MPH	5 MPH	6 MPH	8 MPH	10 MPH	12 MPH	15 MPH	20 MPH	2 MPH	3 MPH	4 MPH	5 MPH		
XR8001 XR11001 (100)	15	F	0.061	7.8	4.5	3.6	3.0	2.3	1.8	1.5	1.2	0.91	0.21	0.14	0.10	0.08		
	20	F	0.071	9.1	5.3	4.2	3.5	2.6	2.1	1.8	1.4	1.1	0.24	0.16	0.12	0.10		
	30	F	0.087	11	6.5	5.2	4.3	3.2	2.6	2.2	1.7	1.3	0.30	0.20	0.15	0.12		
	40	F	0.10	13	7.4	5.9	5.0	3.7	3.0	2.5	2.0	1.5	0.34	0.23	0.17	0.14		
	50	F	0.11	14	8.2	6.5	5.4	4.1	3.3	2.7	2.2	1.6	0.37	0.25	0.19	0.15		
60	VF	0.12	15	8.9	7.1	5.9	4.5	3.6	3.0	2.4	1.8	0.41	0.27	0.20	0.16			
XR80015 XR110015 (100)	15	M	0.092	12	6.8	5.5	4.6	3.4	2.7	2.3	1.8	1.4	0.31	0.21	0.16	0.13		
	20	F	0.11	14	8.2	6.5	5.4	4.1	3.3	2.7	2.2	1.6	0.37	0.25	0.19	0.15		
	30	F	0.13	17	9.7	7.7	6.4	4.8	3.9	3.2	2.6	1.9	0.44	0.29	0.22	0.18		
	40	F	0.15	19	11.1	8.9	7.4	5.6	4.5	3.7	3.0	2.2	0.51	0.34	0.26	0.20		
	50	F	0.17	22	12.6	10.1	8.4	6.3	5.0	4.2	3.4	2.5	0.58	0.39	0.29	0.23		
60	F	0.18	23	13.4	10.7	8.9	6.7	5.3	4.5	3.6	2.7	0.61	0.41	0.31	0.24			
XR8002 XR11002 (50)	15	M	0.12	15	8.9	7.1	5.9	4.5	3.6	3.0	2.4	1.8	0.41	0.27	0.20	0.16		
	20	M	0.14	18	10.4	8.3	6.9	5.2	4.2	3.5	2.8	2.1	0.48	0.32	0.24	0.19		
	30	F	0.17	22	12.6	10.1	8.4	6.3	5.0	4.2	3.4	2.5	0.58	0.39	0.29	0.23		
	40	F	0.20	26	14.9	11.9	9.9	7.4	5.9	5.0	4.0	3.0	0.68	0.45	0.34	0.27		
	50	F	0.22	28	16.3	13.1	10.9	8.2	6.5	5.4	4.4	3.3	0.75	0.50	0.37	0.30		
60	F	0.24	31	17.8	14.3	11.9	8.9	7.1	5.9	4.8	3.6	0.82	0.54	0.41	0.33			
XR80025 XR110025 (50)	15	M	0.15	19	11.1	8.9	7.4	5.6	4.5	3.7	3.0	2.2	0.51	0.34	0.26	0.20		
	20	M	0.18	23	13.4	10.7	8.9	6.7	5.3	4.5	3.6	2.7	0.61	0.41	0.31	0.24		
	30	F	0.22	28	16.3	13.1	10.9	8.2	6.5	5.4	4.4	3.3	0.75	0.50	0.37	0.30		
	40	F	0.25	32	18.6	14.9	12.4	9.3	7.4	6.2	5.0	3.7	0.85	0.57	0.43	0.34		
	50	F	0.28	36	21	16.6	13.9	10.4	8.3	6.9	5.5	4.2	0.95	0.63	0.48	0.38		
60	F	0.31	40	23	18.4	15.3	11.5	9.2	7.7	6.1	4.6	1.1	0.70	0.53	0.42			
XR8003 XR11003 (50)	15	M	0.18	23	13.4	10.7	8.9	6.7	5.3	4.5	3.6	2.7	0.61	0.41	0.31	0.24		
	20	M	0.21	27	15.6	12.5	10.4	7.8	6.2	5.2	4.2	3.1	0.71	0.48	0.36	0.29		
	30	F	0.26	33	19.3	15.4	12.9	9.7	7.7	6.4	5.1	3.9	0.88	0.59	0.44	0.35		
	40	F	0.30	38	22	17.8	14.9	11.1	8.9	7.4	5.9	4.5	1.0	0.68	0.51	0.41		
	50	F	0.34	44	25	20	16.8	12.6	10.1	8.4	6.7	5.0	1.2	0.77	0.58	0.46		
60	F	0.37	47	27	22	18.3	13.7	11.0	9.2	7.3	5.5	1.3	0.84	0.63	0.50			
XR80035 (50)	15	M	0.21	27	15.6	12.5	10.4	7.8	6.2	5.2	4.2	3.1	0.71	0.48	0.36	0.29		
	20	M	0.25	32	18.6	14.9	12.4	9.3	7.4	6.2	5.0	3.7	0.85	0.57	0.43	0.34		
	30	M	0.30	38	22	17.8	14.9	11.1	8.9	7.4	5.9	4.5	1.0	0.68	0.51	0.41		
	40	M	0.35	45	26	21	17.3	13.0	10.4	8.7	6.9	5.2	1.2	0.79	0.60	0.48		
	50	F	0.39	50	29	23	19.3	14.5	11.6	9.7	7.7	5.8	1.3	0.88	0.66	0.53		
60	F	0.43	55	32	26	21	16.0	12.8	10.6	8.5	6.4	1.5	0.97	0.73	0.58			
XR8004 XR11004 (50)	15	C	0.24	31	17.8	14.3	11.9	8.9	7.1	5.9	4.8	3.6	0.82	0.54	0.41	0.33		
	20	M	0.28	36	21	16.6	13.9	10.4	8.3	6.9	5.5	4.2	1.0	0.63	0.48	0.38		
	30	M	0.35	45	26	21	17.3	13.0	10.4	8.7	6.9	5.2	1.2	0.79	0.60	0.48		
	40	M	0.40	51	30	24	19.8	14.9	11.9	9.9	7.9	5.9	1.4	0.91	0.68	0.54		
	50	F	0.45	58	33	27	22	16.7	13.4	11.1	8.9	6.7	1.5	1.0	0.77	0.61		
60	F	0.49	63	36	29	24	18.2	14.6	12.1	9.7	7.3	1.7	1.1	0.83	0.67			
XR8005 XR11005 (50)	15	C	0.31	40	23	18.4	15.3	11.5	9.2	7.7	6.1	4.6	1.1	0.70	0.53	0.42		
	20	M	0.35	45	26	21	17.3	13.0	10.4	8.7	6.9	5.2	1.2	0.79	0.60	0.48		
	30	M	0.43	55	32	26	21	16.0	12.8	10.6	8.5	6.4	1.5	0.97	0.73	0.58		
	40	M	0.50	64	37	30	25	18.6	14.9	12.4	9.9	7.4	1.7	1.1	0.85	0.68		
	50	M	0.56	72	42	33	28	21	16.6	13.9	11.1	8.3	1.9	1.3	0.95	0.76		
60	F	0.61	78	45	36	30	23	18.1	15.1	12.1	9.1	2.1	1.4	1.0	0.83			
XR8006 XR11006 (50)	15	C	0.37	47	27	22	18.3	13.7	11.0	9.2	7.3	5.5	1.3	0.84	0.63	0.50		
	20	M	0.42	54	31	25	21	15.6	12.5	10.4	8.3	6.2	1.4	1.0	0.71	0.57		
	30	M	0.52	67	39	31	26	19.3	15.4	12.9	10.3	7.7	1.8	1.2	0.88	0.71		
	40	M	0.60	77	45	36	30	22	17.8	14.9	11.9	8.9	2.0	1.4	1.0	0.82		
	50	M	0.67	86	50	40	33	25	19.9	16.6	13.3	9.9	2.3	1.5	1.1	0.91		
60	M	0.73	93	54	43	36	27	22	18.1	14.5	10.8	2.5	1.7	1.2	0.99			
XR8008 XR11008 (50)	15	VC	0.49	63	36	29	24	18.2	14.6	12.1	9.7	7.3	1.7	1.1	0.83	0.67		
	20	VC	0.57	73	42	34	28	21	16.9	14.1	11.3	8.5	1.9	1.3	0.97	0.78		
	30	C	0.69	88	51	41	34	26	20	17.1	13.7	10.2	2.3	1.6	1.2	0.94		
	40	M	0.80	102	59	48	40	30	24	19.8	15.8	11.9	2.7	1.8	1.4	1.1		
	50	M	0.89	114	66	53	44	33	26	22	17.6	13.2	3.0	2.0	1.5	1.2		
60	M	0.98	125	73	58	49	36	29	24	19.4	14.6	3.3	2.2	1.7	1.3			
XR8010 † XR11010 †	15	XC	0.61	78	45	36	30	23	18.1	15.1	12.1	9.1	2.1	1.4	1.0	0.83		
	20	VC	0.71	91	53	42	35	26	21	17.6	14.1	10.5	2.4	1.6	1.2	0.97		
	30	C	0.87	111	65	52	43	32	26	22	17.2	12.9	3.0	2.0	1.5	1.2		
	40	M	1.00	128	74	59	50	37	30	25	19.8	14.9	3.4	2.3	1.7	1.4		
	50	M	1.12	143	83	67	55	42	33	28	22	16.6	3.8	2.5	1.9	1.5		
60	M	1.22	156	91	72	60	45	36	30	24	18.1	4.1	2.8	2.1	1.7			
XR8015 † XR11015 †	15	XC	0.92	118	68	55	46	34	27	23	18.2	13.7	3.1	2.1	1.6	1.3		
	20	VC	1.06	136	79	63	52	39	31	26	21	15.7	3.6	2.4	1.8	1.4		
	30	C	1.30	166</														

TEEJET SPRAY TIPS

Turbo TeeJet® Wide Angle Flat Spray Tips

Tip Size	List Price
TT1100*-VP	\$ 7.49
For use with the 25612 TeeJet cap	

Typical Applications:

Mid-range droplet size offers very good coverage with moderate drift control. Ideal for contact products, including herbicides, fungicides and insecticides.

Features:

- Tapered edge wide angle flat spray pattern for uniform coverage in broadcast spraying.
- Large, rounded internal passage to minimize clogging.
- Excellent resistance to corrosive solutions.
- Superior wear characteristics.
- Larger droplets for less drift—15–90 PSI (1–6 bar).
- Automatic spray alignment with 114441-* CELR Quick TeeJet cap and gasket for capacities 01 thru 08; 114502-* CELR for capacities 10 and 12.
- Unique internal configuration means substantially longer wear life.

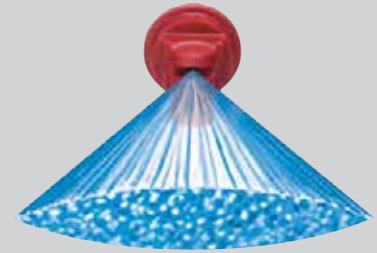

TIPO	PSI	DROPS PER MIN	CAPACITY ONE NOZZLE IN GPM	NOZZLE IN OZ./MIN	GPA										GALLONS PER 1000 SQ. FT.			
					20°													
					4 MPH	5 MPH	6 MPH	8 MPH	10 MPH	12 MPH	15 MPH	20 MPH	2 MPH	3 MPH	4 MPH	5 MPH		
TT11001 (100)	15	C	0.061	7.8	4.5	3.6	3.0	2.3	1.8	1.5	1.2	0.91	0.21	0.14	0.10	0.08		
	20	M	0.071	9.1	5.3	4.2	3.5	2.6	2.1	1.8	1.4	1.1	0.24	0.16	0.12	0.10		
	30	M	0.087	11	6.5	5.2	4.3	3.2	2.6	2.2	1.7	1.3	0.30	0.20	0.15	0.12		
	40	M	0.10	13	7.4	5.9	5.0	3.7	3.0	2.5	2.0	1.5	0.34	0.23	0.17	0.14		
	50	M	0.11	14	8.2	6.5	5.4	4.1	3.3	2.7	2.2	1.6	0.37	0.25	0.19	0.15		
TT110015 (100)	15	VC	0.092	12	6.8	5.5	4.6	3.4	2.7	2.3	1.8	1.4	0.31	0.21	0.16	0.13		
	20	C	0.11	14	8.2	6.7	5.4	4.1	3.3	2.7	2.2	1.6	0.37	0.25	0.19	0.15		
	30	C	0.13	17	9.7	7.7	6.4	4.8	3.9	3.2	2.6	1.9	0.44	0.29	0.22	0.18		
	40	M	0.15	19	11.1	8.9	7.4	5.6	4.5	3.7	3.0	2.2	0.51	0.34	0.26	0.20		
	50	M	0.17	22	12.6	10.1	8.4	6.3	5.0	4.2	3.4	2.5	0.58	0.39	0.29	0.23		
TT11002 (50)	15	VC	0.12	15	8.9	7.1	5.9	4.5	3.6	3.0	2.4	1.8	0.41	0.27	0.20	0.16		
	20	C	0.17	22	12.6	10.1	8.4	6.3	5.0	4.2	3.4	2.5	0.58	0.39	0.29	0.23		
	30	C	0.20	26	14.9	11.9	9.9	7.4	5.9	5.0	4.0	3.0	0.68	0.45	0.34	0.27		
	40	M	0.22	28	16.3	13.1	10.9	8.2	6.5	5.4	4.4	3.3	0.75	0.50	0.37	0.30		
	50	M	0.24	31	17.8	14.3	11.9	8.9	7.1	5.9	4.8	3.6	0.82	0.54	0.41	0.33		
TT110025 (50)	15	VC	0.15	19	11.1	8.9	7.4	5.6	4.5	3.7	3.0	2.2	0.51	0.34	0.26	0.20		
	20	C	0.18	23	13.4	10.7	8.9	6.7	5.3	4.5	3.6	2.7	0.61	0.41	0.31	0.24		
	30	C	0.22	28	16.3	13.1	10.9	8.2	6.5	5.4	4.4	3.3	0.75	0.50	0.37	0.30		
	40	M	0.25	32	18.6	14.9	12.4	9.3	7.4	6.2	5.0	3.7	0.85	0.57	0.43	0.34		
	50	M	0.28	36	21	16.6	13.9	10.4	8.2	6.9	5.5	4.2	0.95	0.63	0.48	0.38		
TT11003 (50)	15	VC	0.21	23	15.6	12.5	10.4	7.8	6.2	5.2	4.2	3.1	0.71	0.48	0.36	0.29		
	20	VC	0.26	33	19.3	15.4	12.9	9.7	7.7	6.4	5.1	3.9	0.88	0.59	0.44	0.35		
	30	C	0.30	38	22	17.8	14.9	11.1	8.9	7.4	5.9	4.5	1.0	0.68	0.51	0.41		
	40	M	0.34	44	25	20	16.8	12.6	10.1	8.4	6.7	5.0	1.2	0.77	0.58	0.46		
	50	M	0.37	47	27	22	18.3	13.7	11.0	9.2	7.3	5.5	1.3	0.84	0.63	0.50		
TT11004 (50)	15	XC	0.24	31	17.8	14.3	11.9	8.9	7.1	5.9	4.8	3.6	0.82	0.54	0.41	0.33		
	20	C	0.28	36	21	16.6	13.9	10.4	8.2	6.9	5.5	4.2	0.95	0.63	0.48	0.38		
	30	C	0.35	45	26	21	17.3	13.0	10.4	8.7	6.9	5.2	1.2	0.79	0.60	0.48		
	40	M	0.40	51	30	24	19.8	14.9	11.9	9.9	7.9	5.9	1.4	0.91	0.68	0.54		
	50	M	0.45	58	33	27	22	16.7	13.4	11.1	8.9	6.7	1.5	1.0	0.77	0.61		
TT11005 (50)	15	VC	0.31	40	23	18.4	15.3	12.2	9.2	7.7	6.1	4.6	1.1	0.70	0.53	0.42		
	20	C	0.35	45	26	21	17.3	13.0	10.4	8.7	6.9	5.2	1.2	0.79	0.60	0.48		
	30	C	0.43	55	32	26	21	16.0	12.8	10.6	8.5	6.4	1.5	0.97	0.73	0.58		
	40	M	0.50	64	37	30	25	18.6	14.9	12.4	9.9	7.4	1.7	1.1	0.85	0.68		
	50	M	0.56	72	42	33	28	21	16.6	13.9	11.1	8.3	1.9	1.3	0.95	0.76		
TT11006 (50)	15	VC	0.37	47	27	22	18.3	13.7	11.0	9.2	7.3	5.5	1.3	0.84	0.63	0.50		
	20	VC	0.42	54	31	25	21	15.6	12.5	10.4	8.3	6.2	1.4	0.95	0.71	0.57		
	30	C	0.52	67	39	31	26	19.3	15.4	12.9	10.3	7.7	1.8	1.2	0.88	0.71		
	40	M	0.60	77	45	36	30	22	17.8	14.9	11.9	8.9	2.0	1.4	1.0	0.82		
	50	M	0.67	86	50	40	33	25	19.9	16.6	13.3	9.9	2.3	1.5	1.1	0.91		
TT11008 (50)	15	VC	0.49	63	46	36	29	24	18.2	14.6	12.1	9.7	1.7	1.1	0.83	0.67		
	20	VC	0.57	73	54	43	36	27	22	18.1	14.5	11.1	2.0	1.4	1.0	0.82		
	30	C	0.69	88	51	41	34	26	20	17.1	13.7	10.2	2.3	1.6	1.2	0.94		
	40	M	0.80	111	59	48	40	32	26	22	17.8	12.9	2.7	1.9	1.4	1.1		
	50	M	0.89	124	66	53	44	33	26	22	17.6	13.2	3.0	2.0	1.5	1.2		
TT11010 (NEW!)	15	VC	0.85	109	63	50	42	32	25	21	16.8	12.9	2.9	1.9	1.5	1.2		
	20	VC	1.00	128	74	59	50	37	30	25	19.8	14.9	3.4	2.3	1.7	1.4		
	30	C	1.12	143	83	67	55	42	33	28	22	16.6	3.8	2.5	1.9	1.5		
	40	C	1.22	156	91	72	60	45	36	30	24	18.1	4.2	2.8	2.1	1.7		
	50	C	1.37	175	102	81	68	51	41	34	27	20	4.6	3.1	2.3	1.87		
TT11012 (NEW!)	15	UC	0.61	78	45	36	30	23	18.1	15.1	12.1	9.1	2.1	1.4	1.0	0.83		
	20	UC	0.71	91	53	42	35	26	21	17.6	14.1	10.5	2.4	1.6	1.2	0.97		
	30	VC	0.87	111	65	52	43	32	26	22	17.2	12.9	3.0	2.0	1.5	1.2		
	40	M	1.00	128	74	59	50	37	30	25	19.8	14.9	3.4	2.3	1.7	1.4		
	50	C	1.12	143	83	67	55	42	33	28	22	16.6	3.8	2.5	1.9	1.5		

CONTACT PRODUCT	SYSTEMIC PRODUCT	DRIFT MANAGEMENT
VERY GOOD	VERY GOOD	VERY GOOD
GOOD*	EXCELLENT*	VERY GOOD*

*At pressures below 30 PSI (2.0 bar)

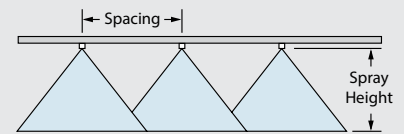

Optimum Spray Height

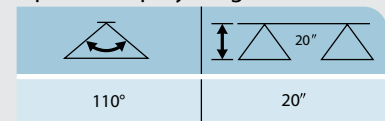

How to order:

Specify tip number.

Example:

TT11001-VP – Polymer with VisiFlo® color-coding

TT11002-VP-CE – Polymer with VisiFlo color-coding, includes Quick TeeJet cap and gasket

Note: Always double check your application rates. Tabulations are based on spraying water at 70°F (21°C).

PRO SERIES SPRAYERS
UTV SPRAYERS
SPOT SPRAYERS
ATV SPRAYERS
TRAILER SPRAYERS
UTILITY & 3PT SPRAYERS
SKID SPRAYERS & BOOMS
PUMPS
SPRAYER ACCESSORIES
DRY MATERIAL SPREADERS
TRAILER CARTS & AERATORS
SPRAYER COMPONENTS
PARTSLIST BREAKDOWNS

TEEJET SPRAY TIPS

AIXR TeeJet® Air Induction XR Flat Spray Tips

Typical Applications:

Air induction design provides good drift control while still providing coverage. Ideal for a wide range of application including post-emerge systemic products.

Features:

- 110° wide, tapered flat spray angle with air induction technology offers better drift management.
- Made of a two-piece UHMWPE polymer construction with VisiFlo® color-coding. UHMWPE provides excellent chemical resistance, including acids, as well as exceptional wear life.
- Compact size to prevent tip damage.
- Depending on the chemical, produces large air-filled drops through a Venturi air aspirator.
- Removable pre-orifice.
- Available in nine tip capacities with a wide operating pressure range: 15-90 PSI (1-6 bar).
- Automatic spray alignment with 114441*-CELR Quick TeeJet® cap and gasket for capacities 015 thru 06; 114443*-CELR for capacities 08 thru 10.



Tip Size	List Price
AIXR1100*VP	\$ 8.27

For use with the 25612 TeeJet cap

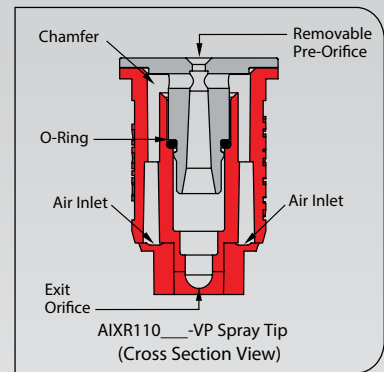

TIPOLOGY	TIPOLOGY	PSI	DROP SIZE	CAPACITY ONE NOZZLE IN GPM	CAPACITY ONE NOZZLE IN OZ./MIN.	GPA										GALLONS PER 1000 SQ. FT.			
						20"													
						4 MPH	5 MPH	6 MPH	8 MPH	10 MPH	12 MPH	15 MPH	20 MPH	2 MPH	3 MPH	4 MPH	5 MPH		
AIXR110015 (100)	15	XC	0.092	12	6.8	5.5	4.6	3.4	2.7	2.3	1.8	1.4	0.31	0.21	0.16	0.13			
	20	VC	0.11	14	8.2	6.5	5.4	4.1	3.3	2.7	2.2	1.6	0.37	0.25	0.19	0.15			
	30	C	0.13	17	9.7	7.7	6.4	4.8	3.9	3.2	2.6	1.9	0.44	0.29	0.22	0.18			
	40	C	0.15	19	11.1	8.9	7.4	5.6	4.5	3.7	3.0	2.2	0.51	0.34	0.26	0.20			
	50	M	0.17	22	12.6	10.1	8.4	6.3	5.0	4.2	3.4	2.5	0.58	0.39	0.29	0.23			
AIXR11002 (50)	15	XC	0.18	23	13.4	10.7	8.9	6.7	5.3	4.5	3.6	2.7	0.61	0.41	0.31	0.24			
	20	VC	0.21	27	15.6	12.5	10.4	7.8	6.2	5.2	4.2	3.1	0.71	0.48	0.36	0.29			
	30	C	0.23	29	17.1	13.7	11.4	8.5	6.8	5.7	4.6	3.4	0.78	0.52	0.39	0.31			
	40	C	0.26	33	19.3	15.4	12.9	9.7	7.7	6.4	5.1	3.9	0.88	0.59	0.44	0.35			
	50	M	0.30	38	22	17.8	14.9	11.1	8.9	7.4	5.9	4.4	1.0	0.68	0.51	0.41			
AIXR110025 (50)	15	XC	0.18	23	13.4	10.7	8.9	6.7	5.3	4.5	3.6	2.7	0.61	0.41	0.31	0.24			
	20	VC	0.22	28	16.3	13.1	10.9	8.2	6.5	5.4	4.4	3.3	0.75	0.50	0.37	0.30			
	30	C	0.25	32	18.6	14.9	12.4	9.3	7.4	6.2	5.0	3.7	0.85	0.57	0.43	0.34			
	40	C	0.28	36	21	16.6	13.9	10.4	8.3	6.9	5.5	4.2	0.95	0.63	0.48	0.38			
	50	M	0.31	40	23	18.4	15.3	11.5	9.2	7.7	6.1	4.6	1.1	0.70	0.53	0.42			
AIXR11003 (50)	15	XC	0.18	23	13.4	10.7	8.9	6.7	5.3	4.5	3.6	2.7	0.61	0.41	0.31	0.24			
	20	VC	0.21	27	15.6	12.5	10.4	7.8	6.2	5.2	4.2	3.1	0.71	0.48	0.36	0.29			
	30	C	0.26	33	19.3	15.4	12.9	9.7	7.7	6.4	5.1	3.9	0.88	0.59	0.44	0.35			
	40	C	0.30	38	22	17.8	14.9	11.1	8.9	7.4	5.9	4.4	1.0	0.68	0.51	0.41			
	50	M	0.34	44	25	20	16.8	12.6	10.1	8.4	6.7	5.0	1.2	0.77	0.58	0.46			
AIXR11004 (50)	15	XC	0.24	31	17.8	14.3	11.9	8.9	7.1	5.9	4.8	3.6	0.82	0.54	0.41	0.33			
	20	VC	0.28	36	21	16.6	13.9	10.4	8.3	6.9	5.5	4.2	0.95	0.63	0.48	0.38			
	30	C	0.35	45	26	21	17.3	13.0	10.4	8.7	6.9	5.2	1.2	0.79	0.60	0.48			
	40	VC	0.40	51	30	24	19.8	14.9	11.9	9.9	7.9	5.9	1.4	0.91	0.68	0.54			
	50	M	0.45	58	33	27	22	16.7	13.4	11.1	8.9	6.7	1.5	1.0	0.77	0.61			
AIXR11005 (50)	15	XC	0.31	40	23	18.4	15.3	11.5	9.2	7.7	6.1	4.6	1.1	0.70	0.53	0.42			
	20	VC	0.35	45	26	21	17.3	13.0	10.4	8.7	6.9	5.2	1.2	0.79	0.60	0.48			
	30	C	0.43	55	32	26	21	16.0	12.8	10.6	8.5	6.4	1.5	0.97	0.73	0.58			
	40	VC	0.50	64	37	30	25	18.6	14.9	12.4	9.9	7.4	1.7	1.1	0.85	0.68			
	50	M	0.56	72	42	33	28	21	16.6	13.9	11.1	8.3	1.9	1.3	0.95	0.76			
AIXR11006 (50)	15	XC	0.37	47	27	22	18.3	13.7	11.0	9.2	7.3	5.5	1.3	0.84	0.63	0.50			
	20	VC	0.42	54	31	25	21	15.6	12.5	10.4	8.3	6.2	1.4	0.95	0.71	0.57			
	30	C	0.52	67	39	31	26	19.3	15.4	12.9	10.3	7.7	1.8	1.2	0.88	0.71			
	40	VC	0.60	77	45	36	30	22	17.8	14.9	11.9	8.9	2.0	1.4	1.0	0.82			
	50	M	0.67	86	50	40	33	25	19.9	16.6	13.3	9.9	2.3	1.5	1.1	0.91			
AIXR11008 (50)	15	XC	0.49	63	36	29	24	18.2	14.6	12.1	9.7	7.3	1.7	1.1	0.85	0.67			
	20	VC	0.57	73	42	34	28	21	16.9	14.1	11.3	8.5	1.9	1.3	0.97	0.78			
	30	C	0.69	88	51	41	34	26	20	17.1	13.7	10.2	2.3	1.6	1.2	0.94			
	40	VC	0.80	102	59	48	40	30	24	19.8	15.8	11.9	2.7	1.8	1.4	1.1			
	50	M	0.89	114	66	53	44	33	26	22	17.6	13.2	3.0	2.0	1.5	1.2			
AIXR11010	15	XC	0.61	78	45	36	30	23	18.1	15.1	12.1	9.1	2.1	1.4	1.0	0.83			
	20	VC	0.71	91	53	42	35	26	21	17.6	14.1	10.5	2.4	1.6	1.2	0.97			
	30	C	0.87	111	65	52	43	32	26	22	17.2	12.9	3.0	2.0	1.5	1.2			
	40	VC	1.00	128	74	59	50	37	30	25	19.8	14.9	3.4	2.3	1.7	1.4			
	50	M	1.12	143	85	67	55	42	33	28	22	16.6	3.8	2.5	1.9	1.5			

CONTACT PRODUCT	SYSTEMIC PRODUCT	DRIFT MANAGEMENT
GOOD	EXCELLENT	EXCELLENT

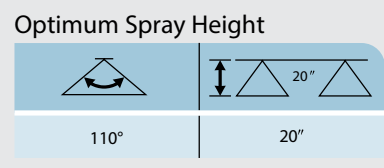
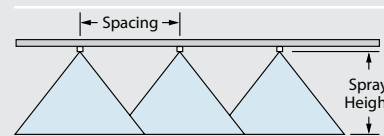

How to order:
Specify tip number.
Example:
AIXR11004VP - Polymer with VisiFlo color-coding
AIXR11003VP-CE - Polymer with VisiFlo color-coding, Includes Quick TeeJet cap and gasket

Note: Always double check your application rates. Tabulations are based on spraying water at 70°F (21°C).

TEEJET SPRAY TIPS

Turbo FloodJet® Wide Angle Flat Spray Tips

Tip Size	List Price
TF-VS*	\$ 15.02
For use with the 25600 TeeJet cap	
TF-VP*	\$ 3.41



Tip Size	PSI	DROPS PER NOZZLE	CAPACITY ONE NOZZLE IN GPM	CAPACITY ONE NOZZLE IN OZ./MIN.	40°								20°									
					GPA													GALLONS PER 1000 SQ. FT.				
					4 MPH	5 MPH	6 MPH	8 MPH	10 MPH	12 MPH	15 MPH	20 MPH	2 MPH	3 MPH	4 MPH	5 MPH						
TF-VS2 (50)	10	XC	0.20	26	7.4	5.9	5.0	3.7	3.0	2.5	2.0	1.5	0.68	0.45	0.34	0.27						
	20	XC	0.28	36	10.4	8.3	6.9	5.2	4.2	3.5	2.8	2.1	0.95	0.63	0.48	0.38						
	40	XC	0.40	51	14.9	11.9	9.9	7.4	5.9	5.0	4.0	3.0	1.4	0.91	0.68	0.54						
TF-VS2.5 (50)	10	XC	0.25	32	9.3	7.4	6.2	4.6	3.7	3.1	2.5	1.9	0.85	0.57	0.43	0.34						
	20	XC	0.35	45	13.0	10.4	8.7	6.5	5.2	4.3	3.5	2.6	1.2	0.79	0.60	0.48						
	30	XC	0.43	55	16.0	12.8	10.6	8.0	6.4	5.3	4.3	3.2	1.5	0.97	0.73	0.58						
TF-VS3 (50)	10	XC	0.30	38	11.1	8.9	7.4	5.6	4.5	3.7	3.0	2.2	1.0	0.68	0.51	0.41						
	20	XC	0.42	54	15.6	12.5	10.4	7.8	6.2	5.2	4.2	3.1	1.4	0.95	0.71	0.57						
	30	XC	0.52	67	19.3	15.4	12.9	9.7	7.7	6.4	5.1	3.9	1.8	1.2	0.88	0.71						
TF-VS4 (50)	10	XC	0.40	51	14.9	11.9	9.9	7.4	5.9	5.0	4.0	3.0	1.4	0.91	0.68	0.54						
	20	XC	0.57	73	21	16.9	14.1	10.6	8.5	7.1	5.6	4.2	1.9	1.3	0.97	0.78						
	30	XC	0.69	88	26	20	17.1	12.8	10.2	8.5	6.8	5.1	2.3	1.6	1.2	0.94						
TF-VS5	10	XC	0.50	64	18.6	14.9	12.4	9.3	7.4	6.2	5.0	3.7	1.7	1.1	0.85	0.68						
	20	XC	0.71	91	26	21	17.6	13.2	10.5	8.8	7.0	5.3	2.4	1.6	1.2	0.97						
	30	XC	0.87	111	32	26	22	16.1	12.9	10.8	8.6	6.5	3.0	2.0	1.5	1.2						
TF-VS7.5	10	XC	1.06	136	39	31	26	19.7	15.7	13.1	10.5	7.9	3.6	2.4	1.8	1.4						
	20	XC	1.30	166	48	39	32	24	19.3	16.1	12.9	9.7	4.4	2.9	2.2	1.8						
	30	XC	1.50	192	56	45	37	28	22	18.6	14.9	11.1	5.1	3.4	2.6	2.0						
TF-VS10	10	XC	1.00	128	37	30	25	18.6	14.9	12.4	9.9	7.4	3.4	2.3	1.7	1.4						
	20	XC	1.41	180	52	42	35	26	21	17.4	14.0	10.5	4.8	3.2	2.4	1.9						
	30	XC	1.73	221	64	51	43	32	26	21	17.1	12.8	5.9	3.9	2.9	2.4						
40	XC	2.00	256	74	59	50	37	30	25	19.8	14.9	6.8	4.5	3.4	2.7							

Note: Always double check your application rates. Tabulations are based on spraying water at 70°F (21°C). †Specify material.



Features:

- Excellent spray distribution for uniform coverage along the boom.
- Nozzle design incorporates a pre-orifice to produce larger droplets for less drift.
- Large, round orifice reduces clogging.
- Stainless steel or polymer with VisiFlo® color-coding band for easy size identification.

Optimum Spray Height

Tip Size	Optimum Spray Height
20°	24**
30°	30**
40°	39**

*Wide angle spray nozzle height is influenced by nozzle orientation. The critical factor is to achieve a minimum 30% overlap.

CONTACT PRODUCT	SYSTEMIC PRODUCT	DRIFT MANAGEMENT
—	VERY GOOD	EXCELLENT

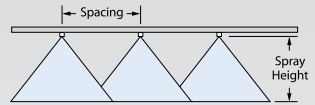

EVEN FLAT SPRAY TIPS

TYPICAL APPLICATIONS:

BEST: Pre-Emerge Herbicides for band application of surface applied herbicides. Used at medium pressures (20-40 P.S.I.) to produce medium size droplets and to control drift.

BEST: Post-Emerge Systemic Herbicides-Used at lower pressures (20-30 P.S.I.) for banding systemic herbicides.

GOOD: Post-Emerge Contact Herbicides-For band application of contact herbicides, used at 40 psi & above to produce small droplets for better coverage.

Features:

- Ideal for banding over the row or in row middles.
- Provides uniform distribution throughout the flat spray pattern.
- Easily mounted on spray boom or planter.
- Tip materials include brass, stainless steel, and hardened stainless steel.
- Available in a range of capacities in 40°, 80° and 95° spray angles.
- VisiFlo color-coded system available in 80° spray angle.

Band Width	Approximate Spray Height				Conversion Factors**
	40° Series	80° Series	95° Series	Conversion Factors**	
8"	10"	5"	4"	3.8	
10"	12"	6"	5"	3.0	
12"	14"	7"	6"	2.5	
15"	19"	9"	8"	2.0	

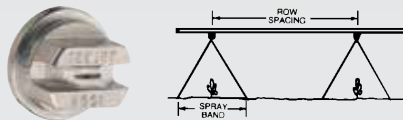

Tip Size	Type	List Price
TP8001E	Brass	\$ 4.85
TP8001E-SS	Stainless	\$ 12.45
TP8001EVs		\$ 7.10

Stainless Steel w/ VisiFlo Color Coding

Tip Color	TIP NO. (STRAINER SCREEN SIZE)	Liquid Pressure in PSI	Capacity 1 Nozzle in GPM	Capacity 1 Nozzle in oz./min	GPA - GALLONS PER ACRE*							
					3 M.P.H.		4 M.P.H.		5 M.P.H.		7 M.P.H.	
					15° SPRAY BAND	30° ROW SPACING	15° SPRAY BAND	30° ROW SPACING	15° SPRAY BAND	30° ROW SPACING	15° SPRAY BAND	30° ROW SPACING
ORANGE	8001E (100 Mesh)	20	.07	9	9.3	4.7	7.0	3.5	5.6	2.8	4.0	2.0
	30	.09	12	11.4	5.7	8.6	4.3	6.9	3.4	4.9	2.4	
	40	.10	13	13.2	6.6	9.9	4.9	7.9	4.0	5.7	2.8	
GREEN	80015E (100 Mesh)	20	.11	14	14.0	7.0	10.5	5.3	8.4	4.2	6.0	3.0
	30	.13	17	17.1	8.6	12.9	6.4	10.3	5.1	7.3	3.7	
	40	.15	19	19.8	9.9	14.8	7.4	11.9	5.9	8.5	4.2	
YELLOW	8002E (50 Mesh)	20	.14	18	18.7	9.3	14.0	7.0	11.2	5.6	8.0	4.0
	30	.17	22	23	11.4	17.1	8.6	13.7	6.9	9.8	4.9	
	40	.20	26	26	13.2	19.8	9.9	15.8	7.9	11.3	5.7	
BLUE	8003E (50 Mesh)	20	.21	27	28	14.0	21	10.5	16.0	8.4	12.0	6.0
	30	.26	33	34	17.1	26	12.9	21	10.3	14.7	7.3	
	40	.30	38	40	19.8	30	14.8	24	11.9	17.0	8.5	
RED	8004E (50 Mesh)	20	.28	36	37	18.7	28	14.0	22	11.2	16.0	8.0
	30	.35	45	46	23	34	17.1	27	13.7	19.6	9.8	
	40	.40	51	53	26	40	19.8	32	15.8	23	11.3	
BROWN	8005E (50 Mesh)	20	.35	45	47	23	35	17.5	28	14.0	20	10.0
	30	.43	55	57	29	43	21	34	17.1	24	12.2	
	40	.50	64	66	33	49	25	40	19.8	28	14.1	
GRAY	8006E (50 Mesh)	20	.42	54	56	28	42	21	34	16.8	24	12.0
	30	.52	67	69	34	51	26	41	21	29	14.7	
	40	.60	77	79	40	59	30	48	24	34	17.0	
WHITE	8008E (50 Mesh)	20	.57	73	75	37	56	28	45	22	32	16.0
	30	.69	88	91	46	69	34	55	27	39	19.6	
	40	.80	102	106	53	79	40	63	32	45	23	

*Gallons Per Acre: (15° SPRAY BAND) GPA application rate on the spray band itself. (30° ROW SPACING) Total gallons used after driving over an actual field acre.

TEEJET SPRAY TIPS

FloodJet® Wide Angle Flat Spray Tips

How to order: Specify tip number.

Examples:

- TK-VS5 – Stainless Steel with VisiFlo® color-coding
- TK-VP3 – Polymer with VisiFlo color-coding
- (B)1/4K-5 – Brass
- TK-SS5 – Stainless Steel
- (B)1/8K-SS5 – Stainless Steel
- QCK-SS100 – Stainless Steel with VisiFlo color-coding



(3/8" - 1" NPT)

Tip Size	List Price
TK-BRASS	\$ 7.82
TK-SS STAINLESS STEEL	\$ 14.23
TK-VS STAIN STEEL/VISIFLO	\$ 13.54

Tip	PSI	CAPACITY ONE NOZZLE IN GPM	GPA 40°								Tip	PSI	CAPACITY ONE NOZZLE IN GPM	GPA 60°							
			4 MPH	5 MPH	6 MPH	8 MPH	10 MPH	12 MPH	15 MPH	20 MPH				4 MPH	5 MPH	6 MPH	8 MPH	10 MPH	12 MPH	15 MPH	20 MPH
1/8K-50 TK-50 (100)	10	0.050	—	—	—	—	—	—	—	1/4K-27	10	2.70	67	53	45	33	27	22	17.8	13.4	
	20	0.071	2.6	2.1	1.8	1.3	1.1	0.88	0.70		0.53	20	3.82	95	76	63	47	38	32	25	18.9
	30	0.087	3.2	2.6	2.2	1.6	1.3	1.1	0.86		0.65	30	4.68	116	93	77	58	46	39	31	23
	40	0.10	3.7	3.0	2.5	1.9	1.5	1.2	0.99		0.74	40	5.40	134	107	89	67	53	45	36	27
1/8K-75 TK-75 (100)	10	0.075	2.8	2.2	1.9	1.4	1.1	0.93	0.74	0.56	3/8K-30 TK-30	10	3.00	74	59	50	37	30	25	19.8	14.9
	20	0.11	4.1	3.3	2.7	2.0	1.6	1.4	1.1	0.82		20	4.24	105	84	70	52	42	35	28	21
	30	0.13	4.8	3.9	3.2	2.4	1.9	1.6	1.3	0.97		30	5.20	129	103	86	64	51	43	34	26
	40	0.15	5.6	4.5	3.7	2.8	2.2	1.9	1.5	1.1		40	6.00	149	119	99	74	59	50	40	30
1/8K-1 TK-1 (100)	10	0.10	3.7	3.0	2.5	1.9	1.5	1.2	0.99	0.74	3/8K-35	10	3.50	87	69	58	43	35	29	23	17.3
	20	0.14	5.2	4.2	3.5	2.6	2.1	1.7	1.4	1.0		20	4.95	123	98	82	61	49	41	33	25
	30	0.17	6.3	5.0	4.2	3.2	2.5	2.1	1.7	1.3		30	6.06	150	120	100	75	60	50	40	30
	40	0.20	7.4	5.9	5.0	3.7	3.0	2.5	2.0	1.5		40	7.00	173	139	116	87	69	58	46	35
1/8K-1.5 TK-1.5 (50)	10	0.15	5.6	4.5	3.7	2.8	2.2	1.9	1.5	1.1	[3/8K, 1/2K]-40	10	4.00	99	79	66	50	40	33	26	19.8
	20	0.21	7.8	6.2	5.2	3.9	3.1	2.6	2.1	1.6		20	5.66	140	112	93	70	56	47	37	28
	30	0.26	9.7	7.7	6.4	4.8	3.9	3.2	2.6	1.9		30	6.93	172	137	114	86	69	57	46	34
	40	0.30	11.1	8.9	7.4	5.6	4.5	3.7	3.0	2.2		40	8.00	198	158	132	99	79	66	53	40
[1/8K, 1/4K, TK]-2 TK-2 (50)	10	0.20	7.4	5.9	5.0	3.7	3.0	2.5	2.0	1.5	3/8K-45	10	4.50	111	89	74	56	45	37	30	22
	20	0.28	10.4	8.3	6.9	5.2	4.2	3.5	2.8	2.1		20	6.36	157	126	105	79	63	52	42	31
	30	0.35	13.0	10.4	8.7	6.5	5.2	4.3	3.5	2.6		30	7.79	193	154	129	96	77	64	51	39
	40	0.40	14.9	11.9	9.9	7.4	5.9	5.0	4.0	3.0		40	9.00	223	178	149	111	89	74	59	45
[1/8K, 1/4K, TK]-2.5 TK-2.5 (50)	10	0.25	9.3	7.4	6.2	4.6	3.7	3.1	2.5	1.9	1/2K-50	10	5.00	124	99	83	62	50	41	33	25
	20	0.35	13.0	10.4	8.7	6.5	5.2	4.3	3.5	2.6		20	7.07	175	140	117	87	70	58	47	35
	30	0.43	16.0	12.8	10.6	8.0	6.4	5.3	4.3	3.2		30	8.66	214	171	143	107	86	71	57	43
	40	0.50	18.6	14.9	12.4	9.3	7.4	6.2	5.0	3.7		40	10.0	248	198	165	124	99	83	66	50
[1/8K, 1/4K, TK]-3 [TK]-3 (50)	10	0.30	11.1	8.9	7.4	5.6	4.5	3.7	3.0	2.2	1/2K-60	10	6.00	149	119	99	74	59	50	40	30
	20	0.42	15.6	12.5	10.4	7.8	6.2	5.2	4.2	3.1		20	8.49	210	168	140	105	84	70	56	42
	30	0.52	19.3	15.4	12.9	9.7	7.7	6.4	5.1	3.9		30	10.4	257	206	171	129	103	86	69	51
	40	0.60	22	17.8	14.9	11.1	8.9	7.4	5.9	4.5		40	12.0	297	238	198	149	119	99	79	59
[1/8K, TK]-4 TK-4 (50)	10	0.40	14.9	11.9	9.9	7.4	5.9	5.0	4.0	3.0	1/2K-70	10	7.00	173	139	116	87	69	58	46	35
	20	0.57	21	16.9	14.1	10.6	8.5	7.1	5.6	4.2		20	9.90	245	196	163	123	98	82	65	49
	30	0.69	26	20	17.1	12.8	10.2	8.5	6.8	5.1		30	12.1	300	240	200	150	120	100	80	60
	40	0.80	30	24	19.8	14.9	11.9	9.9	7.9	5.9		40	14.0	347	277	231	173	139	116	92	69
[1/8K, 1/4K, TK]-5 [TK]-5 (50)	10	0.50	18.6	14.9	12.4	9.3	7.4	6.2	5.0	3.7	[1/2K, 3/4K]-80	10	8.00	198	158	132	99	79	66	53	40
	20	0.71	26	21	17.6	13.2	10.5	8.8	7.0	5.3		20	11.3	280	224	186	140	112	93	75	56
	30	0.87	32	26	22	16.1	12.9	10.8	8.6	6.5		30	13.9	344	275	229	172	138	115	92	69
	40	1.00	37	30	25	18.6	14.9	12.4	9.9	7.4		40	16.0	396	317	264	198	158	132	106	79
[1/8K, 1/4K, TK]-7.5 TK-7.5 (50)	10	0.75	28	22	18.6	13.9	11.1	9.3	7.4	5.6	[1/2K, 3/4K]-90	10	9.00	223	178	149	111	89	74	59	45
	20	1.06	39	31	26	19.7	15.7	13.1	10.5	7.9		20	12.7	314	251	210	157	126	105	84	63
	30	1.30	48	39	32	24	19.3	16.1	12.9	9.7		30	15.6	386	309	257	193	154	129	103	77
	40	1.50	56	45	37	28	22	18.6	14.9	11.1		40	18.0	446	356	297	223	178	149	119	89
[1/8K, 1/4K, TK]-10 TK-10 (50)	10	1.00	37	30	25	18.6	14.9	12.4	9.9	7.4	3/4K-100	10	10.0	248	198	165	124	99	83	66	50
	20	1.41	52	42	35	26	21	17.4	14.0	10.5		20	14.1	349	279	233	174	140	116	93	70
	30	1.73	64	51	43	32	26	21	17.1	12.8		30	17.3	428	343	285	214	171	143	114	86
	40	2.00	74	59	50	37	30	25	19.8	14.9		40	20.0	495	396	330	248	198	165	132	99
[1/8K, 1/4K]-12	10	1.20	45	36	30	22	17.8	14.9	11.9	8.9	3/4K-110	10	11.0	272	218	182	136	109	91	73	54
	20	1.70	63	50	42	32	25	21	16.8	12.6		20	15.6	386	309	257	193	154	129	103	77
	30	2.08	77	62	51	39	31	26	21	15.4		30	19.1	473	378	315	236	189	158	126	95
	40	2.40	89	71	59	45	36	30	24	17.8		40	22.0	545	436	363	272	218	182	145	109
[1/8K, 1/4K]-15 TK-15	10	1.50	56	45	37	28	22	18.6	14.9	11.1	[1/2K, 3/4K]-120	10	12.0	297	238	198	149	119	99	79	59
	20	2.12	79	63	52	39	31	26	21	15.7		20	17.0	421	337	281	210	168	140	112	84
	30	2.60	97	77	64	48	39	32	26	19.3		30	20.8	515	412	343	257	206	172	137	103
	40	3.00	111	89	74	56	45	37	30	22		40	24.0	594	475	396	297	238	198	158	119
[1/8K, 1/4K]-18	10	1.80	67	53	45	33	27	22	17.8	13.4	3/4K-140	10	14.0	347	277	231	173	139	116	92	69
	20	2.55	95	76	63	47	38	32	25	19		20	19.8	490	392	327	245	196	163	131	98
	30	3.12	116	93	77	58	46	39	31	23		30	24.2	599	479	399	299	240	200	160	120
	40	3.60	134	107	89	67	53	45	36	27		40	28.0	693	554	462	347	277	231	185	139
[1/8K, 1/4K]-20 TK-20	10	2.00	74	59	50	37	30	25	19.8	14.9	QCK-150	10	15.0	371	297	248	186	149	124	99	74
	20	2.83	105	84	70	53	42	35	28	21		20	21.2	525	420	350	262	210	175	140	105
	30	3.46	128	103	86	64	51	43	34	26		30	26.0	644	515	429	322	257	215	1	

TEEJET SPRAY TIPS

TeeJet® Disc-Core Type Cone Spray Tips

For spraying pesticides at higher pressures and flow rates. Especially suitable for wettable powders and other abrasive chemicals. Larger capacity nozzles are also used in air blast sprayers.

- Produce smaller droplets for thorough coverage with contact pesticides and foliar applications.
- Maximum spray pressure to 300 PSI (20 bar).

Orifice Discs

Available in a variety of sizes and materials. Ceramic for increased wear life, hardened stainless steel, stainless steel and polymer.

Ceramic Sizes Available:

DCER-2 through DCER-8, DCER-10.

Typical Assembly with Ceramic Disc and Core

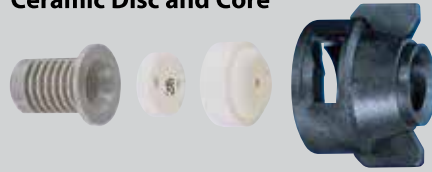

CP26277-1-NY Quick TeeJet® Cap for ceramic disc and core.



Ceramic Hardened Stainless Steel Stainless Steel Polymer

TO ORDER ORIFICE DISC ONLY, SPECIFY DISC NUMBER MATERIAL.

Part #	Description	List Price
DCER-*	Ceramic	\$ 4.68
D*	Hardened Stainless Steel	\$ 1.69
DE*	Stainless Steel	\$ 1.53
DVP-*	Polymer	\$ 1.08

TO ORDER CORE ONLY, SPECIFY CORE NUMBER MATERIAL.

Part #	Description	List Price
DC*-CER	Ceramic	\$ 7.12
DC*-HSS	Hardened Stainless Steel	\$ 7.07
DC*-AL	Aluminum	\$ 1.68
DC*	Brass	\$ 2.95
DC*-NY	Nylon	\$ 1.53

Nozzle	PSI	CAPACITY NOZZLE IN GPM	CAPACITY ONE NOZZLE IN OZ./MIN.	GPA Δ 20"								
				4 MPH	5 MPH	6 MPH	8 MPH	10 MPH	12 MPH	15 MPH	20 MPH	
D2	DC13	40	0.08	10	5.9	4.8	4.0	3.0	2.4	2.0	1.6	1.2
		60	0.10	13	7.4	5.9	5.0	3.7	3.0	2.5	2.0	1.5
		80	0.11	14	8.2	6.5	5.4	4.1	3.3	2.7	2.2	1.6
		100	0.12	15	8.9	7.1	5.9	4.5	3.6	3.0	2.4	1.8
		150	0.14	18	10.4	8.3	6.9	5.2	4.2	3.5	2.8	2.1
D3	DC13	40	0.09	12	6.7	5.3	4.5	3.3	2.7	2.2	1.8	1.3
		60	0.11	14	8.2	6.5	5.4	4.1	3.3	2.7	2.2	1.6
		80	0.12	15	8.9	7.1	5.9	4.5	3.6	3.0	2.4	1.8
		100	0.13	17	9.7	7.7	6.4	4.8	3.9	3.2	2.6	1.9
		150	0.16	20	11.9	9.5	7.9	5.9	4.8	4.0	3.2	2.4
D4	DC13	40	0.12	15	8.9	7.1	5.9	4.5	3.6	3.0	2.4	1.8
		60	0.14	18	10.4	8.3	6.9	5.2	4.2	3.5	2.8	2.1
		80	0.16	20	11.9	9.5	7.9	5.9	4.8	4.0	3.2	2.4
		100	0.17	22	12.6	10.1	8.4	6.3	5.0	4.2	3.4	2.5
		150	0.20	26	14.9	11.9	9.9	7.4	5.9	5.0	4.0	3.0
D2	DC23	40	0.10	13	7.4	5.9	5.0	3.7	3.0	2.5	2.0	1.5
		60	0.13	17	9.7	7.7	6.4	4.8	3.9	3.2	2.6	1.9
		80	0.14	18	10.4	8.3	6.9	5.2	4.2	3.5	2.8	2.1
		100	0.16	20	11.9	9.5	7.9	5.9	4.8	4.0	3.2	2.4
		150	0.19	24	14.1	11.3	9.4	7.1	5.6	4.7	3.8	2.8
D3	DC23	40	0.12	15	8.9	7.1	5.9	4.5	3.6	3.0	2.4	1.8
		60	0.14	18	10.4	8.3	6.9	5.2	4.2	3.5	2.8	2.1
		80	0.16	20	11.9	9.5	7.9	5.9	4.8	4.0	3.2	2.4
		100	0.18	23	13.4	10.7	8.9	6.7	5.3	4.5	3.6	2.7
		150	0.21	27	15.6	12.5	10.4	7.8	6.2	5.2	4.2	3.1
D4	DC23	40	0.15	19	11.1	8.9	7.4	5.6	4.5	3.7	3.0	2.2
		60	0.19	24	14.1	11.3	9.4	7.1	5.6	4.7	3.8	2.8
		80	0.21	27	15.6	12.5	10.4	7.8	6.2	5.2	4.2	3.1
		100	0.23	29	17.1	13.7	11.4	8.5	6.8	5.7	4.6	3.4
		150	0.28	36	21	16.6	13.9	10.4	8.3	6.9	5.5	4.2
D5	DC23	40	0.18	23	13.4	10.7	8.9	6.7	5.3	4.5	3.6	2.7
		60	0.22	28	16.3	13.1	10.9	8.2	6.5	5.4	4.4	3.3
		80	0.25	32	18.6	14.9	12.4	9.3	7.4	6.2	5.0	3.7
		100	0.28	36	21	16.6	13.9	10.4	8.3	6.9	5.5	4.2
		150	0.34	44	25	20	16.8	12.6	10.1	8.4	6.7	5.0
D2	DC25	40	0.16	20	11.9	9.5	7.9	5.9	4.8	4.0	3.2	2.4
		60	0.19	24	14.1	11.3	9.4	7.1	5.6	4.7	3.8	2.8
		80	0.22	28	16.3	13.1	10.9	8.2	6.5	5.4	4.4	3.3
		100	0.25	32	18.6	14.9	12.4	9.3	7.4	6.2	5.0	3.7
		150	0.29	37	22	17.2	14.4	10.8	8.6	7.2	5.7	4.3
D3	DC25	40	0.19	24	14.1	11.3	9.4	7.1	5.6	4.7	3.8	2.8
		60	0.23	29	17.1	13.7	11.4	8.5	6.8	5.7	4.6	3.4
		80	0.26	33	19.3	15.4	12.9	9.7	7.7	6.4	5.1	3.9
		100	0.29	37	22	17.2	14.4	10.8	8.6	7.2	5.7	4.3
		150	0.35	45	26	21	17.3	13.0	10.4	8.7	6.9	5.2
D4	DC25	40	0.29	37	22	17.2	14.4	10.8	8.6	7.2	5.7	4.3
		60	0.35	45	26	21	17.3	13.0	10.4	8.7	6.9	5.2
		80	0.40	51	30	24	19.8	14.9	11.9	9.9	7.9	5.9
		100	0.45	58	33	27	22	16.7	13.4	11.1	8.9	6.7
		150	0.54	69	40	32	27	20	16.0	13.4	10.7	8.0
D5	DC25	40	0.35	45	26	21	17.3	13.0	10.4	8.7	6.9	5.2
		60	0.42	54	31	25	21	15.6	12.5	10.4	8.3	6.2
		80	0.48	61	36	29	24	17.8	14.3	11.9	9.5	7.1
		100	0.54	69	40	32	27	20	16.0	13.4	10.7	8.0
		150	0.65	83	48	39	32	24	19.3	16.1	12.9	9.7
D2	DC45	40	0.20	26	14.9	11.9	9.9	7.4	5.9	5.0	4.0	3.0
		60	0.25	32	18.6	14.9	12.4	9.3	7.4	6.2	5.0	3.7
		80	0.28	36	21	16.6	13.9	10.4	8.3	6.9	5.5	4.2
		100	0.32	41	24	19.0	15.8	11.9	9.5	7.9	6.3	4.8
		150	0.38	49	28	23	18.8	14.1	11.3	9.4	7.5	5.6
D3	DC45	40	0.23	29	17.1	13.7	11.4	8.5	6.8	5.7	4.6	3.4
		60	0.28	36	21	16.6	13.9	10.4	8.3	6.9	5.5	4.2
		80	0.33	42	25	19.6	16.3	12.3	9.8	8.2	6.5	4.9
		100	0.36	46	27	21	17.8	13.4	10.7	8.9	7.1	5.3
		150	0.44	56	33	26	22	16.3	13.1	10.9	8.7	6.5
D4	DC45	40	0.36	46	27	21	17.8	13.4	10.7	8.9	7.1	5.3
		60	0.43	55	32	26	21	16.0	12.8	10.6	8.5	6.4
		80	0.50	64	37	30	25	18.6	14.9	12.4	9.9	7.4
		100	0.56	72	42	33	28	21	16.6	13.9	11.1	8.3
		150	0.68	87	50	40	34	25	20	16.8	13.5	10.1
D5	DC45	40	0.45	58	33	27	22	16.7	13.4	11.1	8.9	6.7
		60	0.55	70	41	33	27	20	16.3	13.6	10.9	8.2
		80	0.64	82	48	38	32	24	19.0	15.8	12.7	9.5
		100	0.71	91	53	42	35	26	21	17.6	14.1	10.5
		150	0.86	110	64	51	43	32	26	21	17.0	12.8



Hollow Cone Spray Pattern

Produced by Cores #13, 23, 25, 45 & 46

Cores

Standard cores are made of brass. Also available in ceramic, hardened stainless steel, aluminum and Nylon. All cores, with the exception of ceramic, are made with rear "nibs". Be sure core is always placed with the nib facing the nozzle body.

Ceramic Sizes Available:

DC13-CER, DC23-CER, DC25-CER, DC31-CER, DC33-CER, DC35-CER, DC45-CER, DC46-CER, DC56-CER.



STRAINER NOTE: For nozzles using orifice disc numbers 1, 1.5 and 2; or core numbers 31 and 33, slotted strainer number 4514-20 equivalent to 25 mesh screen size is required. For all other larger capacity discs and cores, slotted strainer number 4514-32 equivalent to 16 mesh screen size is required.

Note: Always double check your application rates. Tabulations are based on spraying water at 70°F (21°C).

TEEJET SPRAY TIPS

ConeJet® VisiFlo® Hollow Cone Spray Tips

Tip Size

List Price

TX-VS*

\$ 7.50

For use with the 25608 TeeJet cap



Typical Applications:

Excellent: Use for directed applications in air blast spraying for orchards and vineyards and other specialty crops. Also well-suited for applications of insecticides, fungicides, defolants and foliar fertilizers at pressures of 40 PSI (3 bar) and above.

Features:

- VisiFlo color-coded versions consist of stainless steel or ceramic orifice in a polypropylene body.
- Standard ConeJet spray nozzles (not color-coded) are available in brass and stainless steel with 65° (TY) and 80° (TX) spray angles.
- Finely atomized hollow cone spray pattern provides thorough coverage.
- Maximum pressure rating of 300 PSI (20 bar) [spray angle is 80° at 100 PSI (7 bar)].

Tip	Orifice Size (mm)	GPM																	
		30 PSI	40 PSI	50 PSI	60 PSI	70 PSI	80 PSI	90 PSI	100 PSI	120 PSI	140 PSI	160 PSI	180 PSI	200 PSI	220 PSI	240 PSI	260 PSI	280 PSI	300 PSI
TX-VS1	100	0.015	0.017	0.018	0.020	0.021	0.022	0.023	0.024	0.026	0.028	0.030	0.031	0.032	0.034	0.035	0.036	0.037	0.038
		VF	VF	VF	VF	VF	VF	VF	VF	VF	VF	VF	VF	VF	VF	VF	VF	VF	VF
TX-VS2	100	0.029	0.033	0.037	0.040	0.043	0.045	0.047	0.050	0.054	0.058	0.061	0.064	0.067	0.070	0.073	0.075	0.078	0.080
		VF	VF	VF	VF	VF	VF	VF	VF	VF	VF	VF	VF	VF	VF	VF	VF	VF	VF
TX-VK3	100	0.044	0.050	0.055	0.060	0.064	0.068	0.071	0.075	0.081	0.086	0.092	0.096	0.101	0.105	0.109	0.113	0.117	0.120
		F	VF	VF	VF	VF	VF	VF	VF	VF	VF	VF	VF	VF	VF	VF	VF	VF	VF
TX-VK4	50	0.058	0.067	0.074	0.080	0.086	0.091	0.096	0.101	0.110	0.118	0.125	0.132	0.139	0.145	0.151	0.157	0.162	0.167
		F	VF	VF	VF	VF	VF	VF	VF	VF	VF	VF	VF	VF	VF	VF	VF	VF	VF
TX-VK6	50	0.088	0.100	0.111	0.120	0.129	0.137	0.145	0.152	0.165	0.177	0.188	0.199	0.208	0.218	0.226	0.235	0.243	0.251
		F	F	VF	VF	VF	VF	VF	VF	VF	VF	VF	VF	VF	VF	VF	VF	VF	VF
TX-VK8	50	0.116	0.133	0.148	0.162	0.174	0.186	0.196	0.207	0.225	0.243	0.259	0.274	0.288	0.301	0.314	0.326	0.338	0.349
		F	F	VF	VF	VF	VF	VF	VF	VF	VF	VF	VF	VF	VF	VF	VF	VF	VF
TX-VK10	50	0.145	0.167	0.185	0.202	0.218	0.232	0.246	0.258	0.282	0.303	0.323	0.342	0.360	0.376	0.392	0.408	0.422	0.437
		F	F	F	F	VF	VF	VF	VF	VF	VF	VF	VF	VF	VF	VF	VF	VF	VF
TX-VK12	50	0.174	0.200	0.223	0.243	0.261	0.279	0.295	0.310	0.338	0.364	0.388	0.410	0.432	0.452	0.471	0.489	0.507	0.524
		F	F	F	F	VF	VF	VF	VF	VF	VF	VF	VF	VF	VF	VF	VF	VF	VF
TX-VK18	50	0.260	0.300	0.335	0.367	0.396	0.423	0.449	0.473	0.517	0.558	0.597	0.633	0.667	0.699	0.730	0.759	0.788	0.815
		F	F	F	F	F	F	VF	VF	VF	VF	VF	VF	VF	VF	VF	VF	VF	VF
TX-VK26	50	0.376	0.433	0.484	0.530	0.572	0.611	0.648	0.683	0.747	0.807	0.862	0.914	0.963	1.01	1.05	1.10	1.14	1.18
		F	F	F	F	F	F	VF	VF	VF	VF	VF	VF	VF	VF	VF	VF	VF	VF

Note: Always double check your application rates. Tabulations are based on spraying water at 70°F (21°C). See pages 136–157 for useful formulas and other information.

WETBOOM STYLE BOOMLESS NOZZLES

FEATURES:

- Easily Convert Handgun Sprayer To A Broadcast Sprayer (3 GPM Minimum)
- Nozzle Assemblies Fit 5100316 Stainless Steel Tube
- Center Nozzle Assembly Inlet 1/2" Hose
- Shut-Off Valves Built Into Nozzle Assembly
- 30 Foot Total Swath
- Nozzle Assemblies Have Built In Swivel



Part #	Description	List Price
5275122	Polyacetal Left/Right Nozzle Assembly, 13' Coverage	\$ 60.34
5275123	Polyacetal Center Nozzle Assembly, 4' Coverage	\$ 16.94
5100316	Stainless Steel Tube	\$ 27.16

TEEJET SPRAY TIPS

TeeJet® Disc-Core Type Cone Spray Tips

STRAINER NOTE For nozzles using Orifice Disc Nos. 1, 1.5, and 2 or core Nos. 31 and 33. Slotted Strainer No. 4514-20 equivalent to 25 mesh screen size is required. For all other larger capacity Discs and cores. Slotted Strainer No. 4514-32 equivalent to 16 mesh screen size is required.



Full Cone Spray Pattern
Produced By
Cores #31,33,
35, & 56

FULL CONE SPRAY PATTERN															
Orifice Desc. No.	Core No.	Orifice Diam.	CAPACITY GPM (Gallons Per Minute) at PSI (Pounds per Square Inch)										SPRAY ANGLE		
			10 PSI	20 PSI	30 PSI	40 PSI	60 PSI	80 PSI	100 PSI	150 PSI	200 PSI	300 PSI	20 PSI	40 PSI	80 PSI
			D1	31	.031"	.08	.11	.13	.15	.18	.20	.23	.27	.31	.37
D1.5	31	.036"	.10	.14	.17	.19	.23	.26	.29	.35	.40	.48	57°	65°	53°
D2	31	.041"	.12	.16	.19	.22	.26	.30	.33	.40	.45	.55	62°	63°	61°
D3	31	.047"	.13	.18	.21	.24	.29	.33	.37	.44	.50	.60	63°	65°	63°
D1	33	.031"	.09	.11	.12	.14	.17	.20	.22	.26	.30	.37	27°	32°	35°
D1.5	33	.036"	.12	.15	.17	.19	.23	.26	.30	.36	.41	.50	37°	43°	45°
D2	33	.041"	.13	.17	.21	.24	.29	.33	.37	.45	.52	.63	45°	52°	55°
D3	33	.047"	.15	.21	.25	.29	.36	.41	.45	.55	.63	.76	48°	54°	57°
D4	33	.063"	.20	.28	.34	.39	.47	.54	.60	.73	.83	1.02	50°	56°	61°
D1	35	.031"	.08	.11	.13	.14	.17	.20	.22	.26	.29	.35	19°	23°	26°
D1.5	35	.036"	.10	.14	.17	.19	.23	.26	.29	.34	.39	.46	23°	27°	29°
D2	35	.041"	.14	.18	.24	.25	.30	.34	.37	.45	.51	.60	40°	44°	47°
D3	35	.047"	.16	.22	.26	.30	.36	.41	.45	.55	.62	.74	45°	50°	52°
D4	35	.063"	.27	.37	.44	.50	.60	.70	.79	.93	1.1	1.3	68°	70°	71°
D5	35	.078"	.34	.48	.58	.66	.80	.92	1.0	1.2	1.4	1.7	67°	69°	71°
D2	56	.041"	—	—	.21	.25	.30	.35	.39	.47	.55	.67	—	14°	17°
D3	56	.047"	—	—	.29	.34	.41	.48	.53	.65	.75	.92	—	20°	23°
D4	56	.063"	—	.39	.48	.55	.67	.78	.87	1.06	1.23	1.51	20°	26°	29°
D5	56	.078"	.38	.54	.66	.76	.93	1.08	1.20	1.47	1.69	2.08	26°	32°	34°
D6	56	.094"	.55	.78	.95	1.10	1.35	1.55	1.74	2.13	2.46	3.02	34°	39°	41°
D7	56	.109"	.76	1.07	1.32	1.52	1.86	2.15	2.40	2.94	3.40	4.16	45°	52°	54°
D8	56	.125"	.96	1.36	1.67	1.93	2.36	2.73	3.05	3.73	4.32	5.28	52°	57°	59°
D10	56	.156"	1.35	1.91	2.34	2.70	3.31	3.82	4.26	5.22	6.03	7.39	62°	65°	67°

TYPE	SIZE	ORIFICE INSERT / TIP BODY MATERIAL	EXAMPLE TIP #	List Price
 TeeJet® ORIFICE DISCS	ALL SIZES	HARD. STAINLESS STEEL	D2	\$ 1.69
		STAINLESS STEEL	DE2	\$ 1.53
		CERAMIC	DCER-2	\$ 4.68
 TeeJet® CORES	ALL SIZES	NYLON	DC23-NY	\$ 1.53
		BRASS	DC23	\$ 2.95
		HARD. STAINLESS STEEL	DC23-HSS	\$ 7.07
		CERAMIC	DC25-CER	\$ 7.12

PRO SERIES SPRAYERS
UTV SPRAYERS
SPOT SPRAYERS
ATV SPRAYERS
TRAILER SPRAYERS
UTILITY & 3PT SPRAYERS
SKID SPRAYERS & BOOMS
PUMPS
SPRAYER ACCESSORIES
DRY MATERIAL SPREADERS
TRAILER CARTS & AERATORS
SPRAYER COMPONENTS
PARTS LIST BREAKDOWNS

TEEJET SPRAY TIPS

FieldJet® Boomless Nozzles with Extra-Wide Flat Spray Projection



Type 1/4 KLC and Type 3/4 KLC 1/4" NPT MALE and 3/4" NPT MALE pipe connections.

One-piece nozzle design, projects spray to both sides to form wide swath flat spray. Made in choice of brass, aluminum and stainless steel.

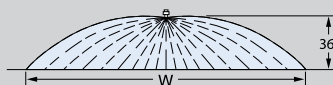

How to order:
Specify part number and material.
Example: 1/4KLC-SS18 - Stainless Steel

Tip Size	List Price
1/4KLC Brass	\$ 48.17
1/4KLC-SS Stainless Steel	\$ 78.82
3/4KLC Brass	\$ 67.32
3/4KLC-SS Stainless Steel	\$ 98.95

FieldJet Nozzle No.	Liquid Press In PSI	Capacity in GPM	"W" Feet	GALLONS PER ACRE					
				4 M.P.H.	5 M.P.H.	7.5 M.P.H.	10 M.P.H.	15 M.P.H.	20 M.P.H.
1/4KLC-5	20	.7	17	5.2	4.1	2.8	2.1	1.4	1.0
	30	.9	18	6.0	4.8	3.2	2.4	1.6	1.2
	40	1.0	21	5.9	4.7	3.1	2.3	1.5	1.1
1/4KLC-9	20	1.3	18	8.8	7.0	4.7	3.5	2.3	1.8
	30	1.6	19	10.1	8.1	5.4	4.1	2.7	2.0
	40	1.8	21	10.6	8.5	5.7	4.2	2.8	2.1
1/4KLC-18	20	2.5	20	15.5	12.4	8.3	6.2	4.1	3.1
	30	3.1	21	18.3	14.6	9.7	7.3	4.9	3.7
	40	3.6	22	20	16.2	10.8	8.1	5.4	4.1
1/4KLC-36	20	5.1	22	29	23	15.3	11.5	7.6	5.7
	30	6.3	24	32	26	17.1	12.9	8.6	6.4
	40	7.2	26	34	27	18.3	13.7	9.1	6.9
3/4KLC-50	20	7.1	23	38	30	20	15.2	10.1	7.6
	30	8.7	26	41	33	22	16.5	11.0	8.2
	40	10.0	28	44	35	24	17.7	11.8	8.8
3/4KLC-72	20	10.2	25	50	40	27	20	13.4	10.1
	30	12.5	29	53	43	28	21	14.2	10.6
	40	14.4	31	57	46	31	23	15.3	11.5
3/4KLC-108	20	15.2	28	67	54	36	27	17.9	13.4
	30	18.7	33	70	56	37	28	18.7	14.0
	40	21.6	36	74	59	40	30	19.8	14.9

BoomJet® Boomless Nozzles with Extra-Wide Flat Spray Projection

Type 5880 BoomJet and 5430 BoomJet Nozzles combine two off-center tips and three VeeJet nozzles to produce an overall wide swath flat spray. Nozzle assembly provides good distribution for the wide pattern coverage obtained. Supplied with one additional 1/4" NPT pipe plug and one blank tip for setting BoomJet to spray to one side only. Type 5880 also has a 1/4" NPT pressure gauge port.



W = Maximum effective coverage with nozzle mounted at 36" height.



TYPE 5880 - 3/4" NPT FEMALE back inlet connection.
WEIGHTS: Brass 2 POUNDS



TYPE 5430 - 3/4" NPT FEMALE top inlet connection.
WEIGHTS: Brass 2-1/2 pounds

COMPLETE BOOMJETS	List Price
5880-3/4-2TOC	\$ 295.68
5430-3/4-2TOC	\$ 261.85
OFFCENTER BRASS TIPS ONLY	List Price
6733-OC06	\$ 50.72
OC-10	\$ 52.93
OC-20	\$ 52.93
OC-40	\$ 52.93

Fimco CODE NO.	BoomJet NOZZLE NO.	OC TIPS (Two)	VeeJet Top Nozzles (Two)	VeeJet Bottom Nozzle	Liquid Pressure p.s.i.	Total Capacity G.P.M.	"W" Feet	GALLONS PER ACRE				
								4 M.P.H.	5 M.P.H.	7.5 M.P.H.	10 M.P.H.	15 M.P.H.
5138554	5880-3/4-2TOC06	6733-OC06	H1/4VV-1506	H1/4VVL-9502 with 50 mesh strainer	20	1.8	33-1/2	6.8	5.4	3.5	2.7	1.8
5138557	5430-3/4-2TOC06				30	2.3	34	8.2	6.6	4.4	3.3	2.2
					40	2.6	34-1/2	9.3	7.5	5.0	3.7	2.5
5138475	5880-3/4-2TOC10	OC-10	H1/4U-0508HE	H1/4VVL-11004 with 50 mesh strainer	20	2.8	39-1/2	8.9	7.1	4.7	3.5	2.4
5138539	5430-3/4-2TOC10				30	3.5	40	10.7	8.6	5.7	4.3	2.9
					40	4.0	40-1/2	12.2	9.8	6.5	4.9	3.3
5138555	5880-3/4-2TOC20	OC-20	H1/4U-0520HE	H1/4VVL-9506 with 50 mesh strainer	20	6.1	47	16.0	12.8	8.5	6.4	4.3
5138558	5430-3/4-2TOC20				30	7.4	50	18.4	14.7	9.8	7.4	4.9
					40	8.6	52	20	16.4	10.9	8.2	5.5
5138556	5880-3/4-2TOC40	OC-40	H1/4U-0540HE	H1/4U-9510	20	12.0	56	27	21	14.2	10.6	7.1
5138559	5430-3/4-2TOC40				30	14.7	60	30	24	16.2	12.1	8.1
					40	17.0	63	33	27	17.8	13.4	8.9

TEEJET SPRAY TIPS & CALIBRATION CONTAINER

OFF-CENTER FLAT SPRAY TIPS - SMALLER CAPACITIES

TeeJet Off-Center spray tips are commonly installed in double and single swivel nozzle bodies. Because these bodies are adjustable for angular position, a wide spray swath is easily obtained.

How To Order: Specify tip no., material.
Example: OC-02 brass.

Extra Wide Flat Spray Coverage

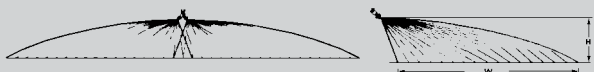

Part #	Description	List Price
OC	Brass Off Center Tip	\$ 12.69
OC-SS	Stainless Steel Off Center Tip	\$ 18.76

FieldJet Nozzle No.	Liquid Press In PSI	Capacity in GPM	SPRAYING HEIGHT "H" = 18"						SPRAYING HEIGHT "H" = 24"					
			"W" in Inches	GALLONS PER ACRE*			"W" in Inches	GALLONS PER ACRE*						
				3 M.P.H.	4 M.P.H.	5 M.P.H.		3 M.P.H.	4 M.P.H.	5 M.P.H.				
OC-02	30	.17	68	4.9	3.7	3.0	75	4.5	3.4	2.7				
	40	.20	70	5.6	4.2	3.4	77	5.1	3.9	3.1				
	60	.25	72	6.9	5.1	4.1	78	6.3	4.7	3.8				
OC-03	30	.26	77	6.7	5.0	4.0	80	6.4	4.8	3.9				
	40	.30	80	7.5	5.6	4.5	83	7.1	5.3	4.3				
	60	.37	82	8.9	6.7	5.3	85	8.6	6.3	5.2				
OC-04	30	.35	91	7.6	5.7	4.6	93	7.4	5.6	4.5				
	40	.40	93	8.5	6.4	5.1	94	8.4	6.3	5.1				
	60	.49	94	10.5	7.7	6.2	95	10.2	7.6	6.1				
OC-06	30	.52	99	10.4	7.8	6.2	108	9.5	7.1	5.7				
	40	.60	101	11.7	8.8	7.0	110	10.8	8.1	6.5				
	60	.73	102	14.2	10.6	8.5	111	13.0	9.8	7.8				
OC-08	30	.69	100	13.6	10.2	8.2	110	12.4	9.3	7.4				
	40	.80	102	15.5	11.6	9.3	112	14.1	10.6	8.5				
	60	.98	104	18.6	14.0	11.2	113	17.2	12.9	10.4				
OC-12	30	1.0	102	20	15.1	12.1	113	18.2	13.7	10.9				
	40	1.2	104	23	17.1	13.7	115	21	15.5	12.4				
	60	1.5	105	28	21	16.6	116	25	18.8	15.1				
OC-16	30	1.4	132	21	15.7	12.5	142	19.4	14.6	11.6				
	40	1.6	138	23	17.2	13.8	146	22	16.3	13.0				
	60	2.0	143	27	20	16.2	148	26	19.7	15.7				

* Gallons Per Acre coverage is based on water.
See page 3 for Conversion Factors for other weight solutions.

TEEJET CALIBRATION CONTAINER AND CLEANING BRUSH



CALIBRATION CONTAINER



TEEJET CLEANING BRUSH

FIMCO Part #	MFG Part #	Description	List Price
5167037	CP24034A-PP	TeeJet Calibration Container	\$ 46.85
5167039	CP20016-NY	TeeJet Tip Cleaning Brush	\$ 10.38

FIMCO FIELD SPRAYER CALIBRATOR



Direct reading Calibration Scale tells exactly how many gallons per acre being applied. No complex calibration table, charts, etc.

HERE'S ALL YOU DO:

1. Attach Spra-Check to any nozzle outlet.
2. Travel a test run of 150 feet.
3. Read actual "spray rate per acre" on scale.

CALIBRATION CHECK LIST:

1. Inspect sprayer tank. Make sure it is free of rust, scale, dirt, and other foreign matter that could damage vital sprayer parts.
2. Rinse tank and half fill with clean, filtered water. (Filter through a 100 mesh screen before it is put into tank).
3. Remove and clean all nozzles and screens by soaking and brushing them with a stiff-bristled brush. (Do not attempt to clean parts by scraping them with a hard object).

4. Replace suction screen and flush all hoses, controls and booms with clean water.
5. Inspect nozzle screens for correct mesh size. Inspect nozzles for wear and damage and to verify they are all the same size. Spray pattern, spray angle and capacity. Replace all screens and nozzles that do not pass inspection.
6. Align each tip with spray boom.
7. Inspect pressure regulator, valves, controls, pressure gauge and other parts for proper operation.
8. Check all hoses and connections for leaks.
9. Calibrate sprayer over same soil and terrain conditions that will be traveled when actually spraying.

Part #	Description	List Price
5167014	(SC70)Calibrator	\$ 9.43

HANDGUNS

SPRAYING SYSTEMS NO. AA18-AL

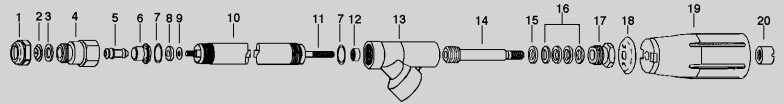

FIMCO Code #	MFG Part #	Description	List Price
5163021	AA18-AL6	20" Aluminum Gun	\$ 92.16

Ref #	FIMCO Code #	MFG Part #	Description	List Price
1	5046033	CP1325-AL	Cap Alum	\$ 1.49
2	5063071	D6	Orifice Disc	\$ 1.69
*3	Available in Kit Only		Tip Gasket, Buna-N	
4	5084050	CP5869-AL	Spray Housing, Alum	\$ 7.68
*5	Available in Kit Only		Core, Rivet & Core Body Sub-Asb., Alum	
6	5077030	CP5872-AL	Guide Sleeve, Alum	\$ 3.45
7	5072285	CP4143-CU	Gasket, Copper	\$ 1.78
*8	Available in Kit Only		Seat Plate, Nylon	
*9	Available in Kit Only		Washer, Type 302 SS	
10	5009278	CP5878-AL	Tubing, Alum	\$ 24.48
11	5132051	CP5879-AL	Stem, Alum	\$ 10.23
12	5006192	CP6618-AL	1/4-28 Nut, Alum	\$ 1.73
13	5002378	CP6896-AL	Inlet Body, Alum	\$ 33.32
14	5134023	CP5882-NP	Hand Grip Stud, Brass, Nickel plated	\$ 12.57
15	5016069	CP5883-AL	Packing Washer, Alum	\$ 1.78
16	5097031	CP5809-LEA	Packing, Thermo-Leather (4 Req'd)	\$ 1.78
17	5117068	CP5811-AL	Packing Screw, Alum	\$ 3.92
18	5016149	CP5884-INP	Hand Grip Collar, Steel, Nickel plated	\$ 9.21
19	5078112	CP5994-NY	Plastic Hand Grip, Nylon	\$ 10.69
20	5006070	CP5813-AL	Hand Grip Nut, Alum	\$ 2.95
*	5168368	PK-AB18-AL-KIT	Spare Parts Kit (Items Marked*)	\$ 25.93

HEAVY DUTY TYPE ROTATING HANDLE CONTROL

Handle rotates 360° to operate spray gun valve from shut-off to maximum flow position. As handle is turned, spray changes from initial cone spray through intermediate cone spray to straight stream. Corrosion and abrasion resistant hardened stainless steel interchangeable orifice discs. Discs may be purchased separately as desired. TeeJet Tips may also be used with these GunJets.

For Pressures: Up To 800 P.S.I.
Overall length: 20"
Weight: 1lbs.

SPRAYING SYSTEMS NO. AA143-AL

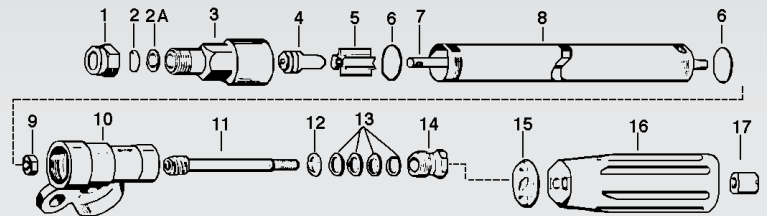

GunJet No. 143-AL-GH--length 22-1/4". Weight 1 - 1/4 pounds, 3/4" Female garden hose thread inlet connection, aluminum.

FIMCO Code #	MFG Part #	Description	List Price
5163014	AA143-AL-GH-6 Gun	3/4" GHT female garden hose connection	\$ 104.06 \$ 92.16

Ref #	FIMCO Code #	MFG Part #	Description	List Price
1	5046033	CP1325-AL	Cap	\$ 1.49
2	5063071	D6	Orifice Disc	\$ 1.69
*2A	Available in Kit Only		Gasket	
3	5084016	CP10566-AL	Housing	\$ 20.27
*4	Available in Kit Only		Seat Plug	
5		CP10571-3-NYB	Guide Vane	\$ 9.56
*6	Available in Kit Only		Gasket(2 Req'd)	
7	5132007	CP10576-416SS	Stem	\$ 22.90
8	5009080	CP6604-AL	Tube	\$ 43.27
9	5006192	CP6618-AL	Nut	\$ 1.73
10	5002195	CP6898-GH-AL	Inlet Body (GH)	\$ 36.70
**11	5134023	CP5882-NP	Hand Grip Stud	\$ 12.57
12	5016069	CP5883-AL	Washer	\$ 1.78
*13	Available in Kit Only		Packing (4 Req'd)	
14	5117068	CP5811-AL	Screw	\$ 3.92
**16	5078112	CP5994-NY	Nylon Hand Grip	\$ 10.69
**17	5006070	CP5813-AL	Hand Grip Nut	\$ 2.95
*	5168187	PK-AB143-AL-KIT	Kit Marked	\$ 33.57

Handle rotates 360° to operate spray gun valve from shut-off to maximum flow position. As handle is turned, spray changes from initial cone spray through intermediate cone spray to straight stream. Corrosion and abrasion resistant hardened stainless steel interchangeable orifice discs. Discs may be purchased separately as desired. TeeJet Tips may also be used with these GunJets.

For Pressures: Up to 800 P.S.I.
Overall length: 22-1/4"
Weight: 1-1/4 lbs.

** Parts necessary to replace handle on older guns

PRO SERIES HANDGUNS & ADAPTERS

22" & 13" PRO SERIES LONG RANGE ERGONOMIC HANDGUNS

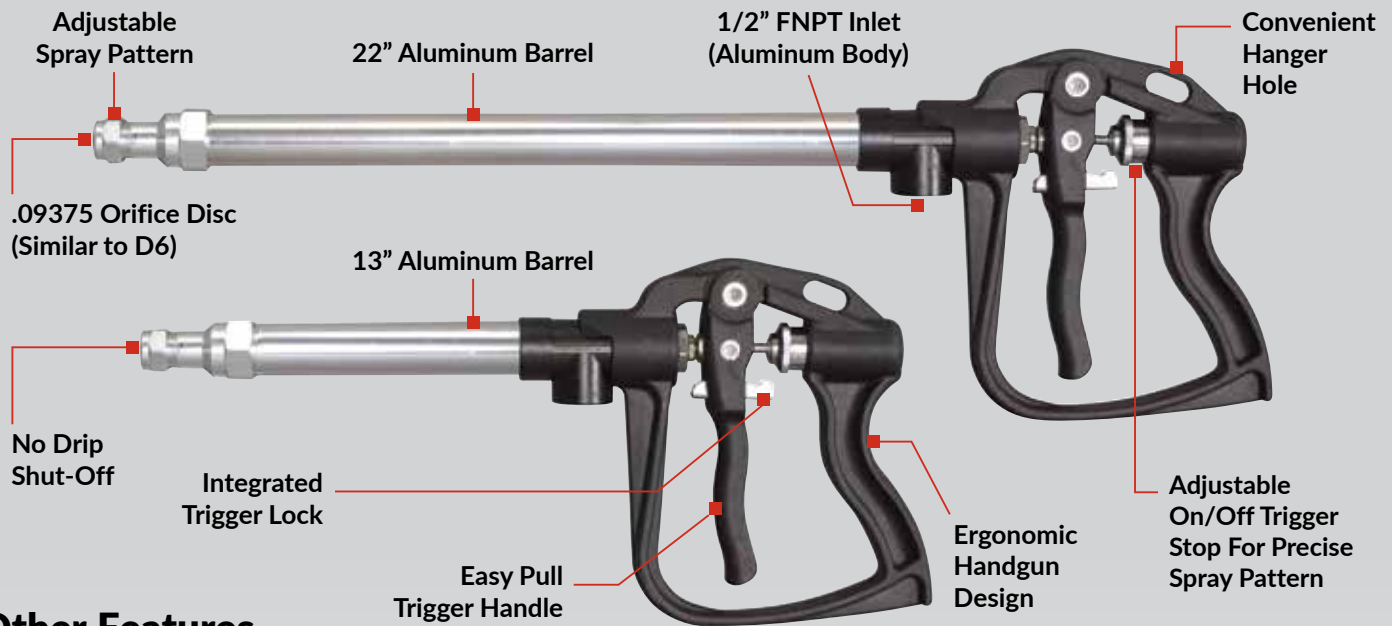

Other Features

- 600 PSI
- 8 GPM
- Chemical Resistant Construction

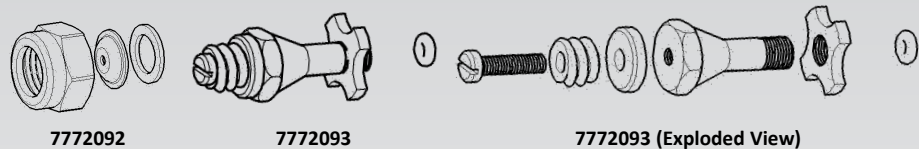

Spray Distance

- 38' Max Horizontal
- 27' Max Vertical

FIMCO Code #	Description	UPC Code	List Price
5163136	22" Long Range Pro Series Handgun	733029115782	\$ 69.00
5163137	13" Long Range Pro Series Handgun	733029115799	\$ 65.00
7772092	End Cap Replacement Kit (End Cap, Gasket, Orifice Disc)		\$ 8.57
7772093	Repair Kit (O-Ring, Valve Core Assembly)		\$ 10.16

BRASS HANDGUN SWIVEL

- The 900 Swivel promotes a compact design for 3/8 NPT fluid hose and air line applications
- The 901 Swivel promotes a compact design for 1/2 NPT fluid hose and air line applications
- The 901 Swivel promotes a compact design for 1/4 NPT fluid hose and air line applications
- Maximum Operating Pressure - 1000 psi
- Bronze Thrust Bearing for low torque with a Buna-N seal is standard

FIMCO Code #	Description	List Price
5930190	3/8" SWIVEL 900-4F4M-F (Viton)	\$ 26.55
5960190	1/2" SWIVEL 901-8F8M-F (Viton)	\$ 41.36
6160190	1/4" SWIVEL 902-6F6M-F (Viton)	\$ 26.73



No. 3056 ADAPTER

Attaches to outlet of No. 46 Trigger Valve, to convert valve to spray gun. Choice of 1/4", 3/8", and 1/2" NPT female outlet connections for attachment of nozzles or extensions.



No. 11740B SWIVEL ADAPTER

Made with 3/4" garden hose thread connections to fit all GunJet Spray Guns above with similar size inlet connections. Provides free-Swiveling, leak-proof connections at pressures up to 800 psi.

FIMCO Code #	MFG Part #	Description	List Price
5005072	3056-1/4	1/4" Brass Adapter	\$ 11.87
5005134	3056-3/8	3/8" Brass Adapter	\$ 11.87
5005135	3056-1/2	1/2" Brass Adapter	\$ 11.87
5057090	11740B	3/4" Garden Hose Swivel Brass	\$ 41.17



HIGH PRESSURE SPRAY GUN, HAND VALVE & TIP

TRIGGER HAND GUN SPRAYING SYSTEM NO. 43H

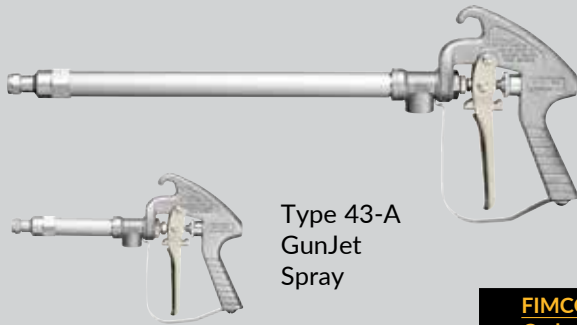

Type 43-A
GunJet
Spray

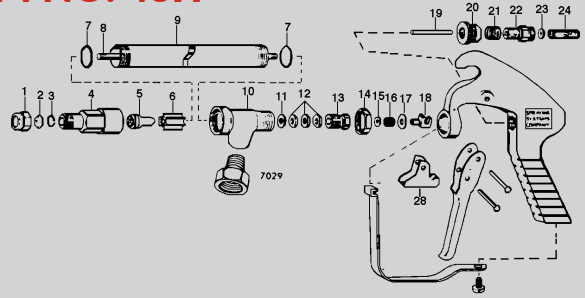

Available in Brass or Aluminum. No. 43H for operating pressures from 200 to 800 PSI

Trigger handle control 1/2" NPT(F) inlet connection for livestock, orchard and nursery spraying field spot spraying and cleaning barns and equipment operate at pressures from 30 to 800 P.S.I.

FIMCO Code #	MFG Part #	Description	List Price
5163006	AA43H-6	23" Brass Gun	\$ 194.29
5163005	AA43H-AL6	23" Aluminum Gun	\$ 161.43
5163007	AA43HA-6	14" Brass Gun	\$ 176.04
5163004	AA43HA-AL6	14" Aluminum Gun	\$ 154.61
5005119	(7029-AL) GHT(F) x 1/2" NPT(M)	Inlet Adapter w/Gasket, Aluminum for No. 43 Gunjets	\$ 13.07

BRASS GUN

ALUMINUM GUN

Ref #	Description	FIMCO Code #	MFG Part #	List Price	FIMCO Code #	MFG Part #	List Price
1	Cap	5046022	CP1325	\$ 1.49	5046033	CP1325-AL	\$ 1.49
2	Orifice Disc, Stainless Steel	5063071	D6	\$ 1.69	5063071	D6	\$ 1.69
3	Orifice Disc, Stainless Steel	Available In Spare Parts Kit Only (Items Marked)					
4	Nozzle Housing	5084023	CP10566	\$ 21.04	5084016	CP10566-AL	\$ 20.27
5	Seat Plug, Assembly	Available In Spare Parts Kit Only (Items Marked)					
6	Guide Vane	-	CP10571-2-NYB	\$ 9.25	-	CP10571-2-NYB	\$ 9.25
7	Gasket, Alum (2 Req'd)	5072172	CP6943-AL	\$ 1.78	5072172	CP6943-AL	\$ 1.78
8	Stem, Stainless Steel	5132039	CP19238-416SS	\$ 26.66	5132039	CP19238-416SS	\$ 26.66
9	Tubing (23")	5009120	CP6604	\$ 43.27	5009080	CP6604-AL	\$ 43.27
10	Inlet Body	5002204	CP6492	\$ 47.99	5002203	CP6492-AL	\$ 33.78
11	Packing Washer	Available In Spare Parts Kit Only (Items Marked)					
12	Packing, (3 Req'd)	Available In Spare Parts Kit Only (Items Marked)					
13	Packing Screw	5117164	CP19237	\$ 5.80	5117165	CP19237-AL	\$ 5.80
14	Locknut	5006063	CP6599	\$ 3.92	5006350	CP6599-NP	\$ 3.92
15	Stem Nut, Steel-Plated	5006244	CP9641-INP	\$ 6.35	5006244	CP9641-INP	\$ 6.35
16	Trigger Stop Spring	5019083	CP6595-SS	\$ 3.44	5019083	CP6595-SS	\$ 3.44
17	Washer	5016061	CP7991-IZP	\$ 1.73	5016061	CP7991-IZP	\$ 1.73
18	Trigger Guide	5166017	CP6597-INP	\$ 18.02	5166017	CP6597-INP	\$ 18.02
19	Spring Stud	5134010	CP6591-SS	\$ 4.10	5134010	CP6591-SS	\$ 4.10
20	Stop Adjusting Nut	5006072	CP6589-IZP	\$ 5.36	5006072	CP6589-IZP	\$ 5.36
21	Spring	5019069	CP6594-SS	\$ 1.84	5019069	CP6594-SS	\$ 1.84
22	Spring Screw	5117070	CP6588-IZP	\$ 5.65	5117070	CP6588-IZP	\$ 5.65
23	Guide Washer	5016071	CP6592-302SS	\$ 2.87	5016071	CP6592-302SS	\$ 2.87
24	Main Spring (For 43H)	5019107	CP6593-2-SS	\$ 5.80	5019107	CP6593-2-SS	\$ 5.80
28	Trigger Stop	5131012	CP6510-INP	\$ 6.00	5131012	CP6510-INP	\$ 6.00
	Spare Parts Kit (Item *)	5168370	PK-AB43-KIT	\$ 44.51	5168190	PK-AB43-AL-KIT	\$ 44.51

HAND VALVE & CONEJET TIP



5138552 &
5138553



5143155



5002294

FIMCO Code #	MFG Part #	Description	Connection		List Price
			In	Out	
5143155	AA36-1/4	Trigger Valve w / Lock	1/4 FNPT	1/4 FNPT	\$ 79.64
5002294	CP1322	Brass Male Nozzle Body	1/4 MNPT	Nozzle Body	\$ 2.57
5138552	5780-AX45	Brass Adjustable Cone Jet Tip	Fits Nozzle Body (1322)		\$ 34.30
5138553	5780-AX60	Brass Adjustable Cone Jet Tip	Fits Nozzle Body (1322)		\$ 34.30

SPRAY GUNS

SPRAY GUN NO. 5163100

- Overall Gun Length is 29"
- Metal Extension is 19" Long w/30° Offset Tip
- Hose Shank Connection is 3/8"
- Tip Has Adjusting Pattern From Cone Spray To Straight Stream
- Maximum Operating Pressure is 100 P.S.I.
- Trigger Locks For Continuous Operation



FIMCO Code #	Description	List Price
5163100	29" Trigger Gun	\$ 12.94
5018330	X-26 Tip Only (Poly)	\$ 5.37

TELESCOPIC WAND HANDGUN - GREAT FOR TREES, HOUSES AND OTHER HARD TO REACH PLACES!



FIMCO Code #	Description	Weight	List Price
5163117	Telescoping wand	3 lbs.	\$ 38.50

SPRAY GUN NO. 22670

22670-PP



22650 TriggerJet

22670-PP Includes:

- 22650 Triggerjet Spray Gun (1/4" FNPT Only)
- 15" or 24" Extension Wand
- 8079 50 Mesh Strainer
- 5500 PPB-X8 Adjustable Conejet Spray Tip
- Straight and 45° adapter
- Maximum Operating Pressure 150 PSI

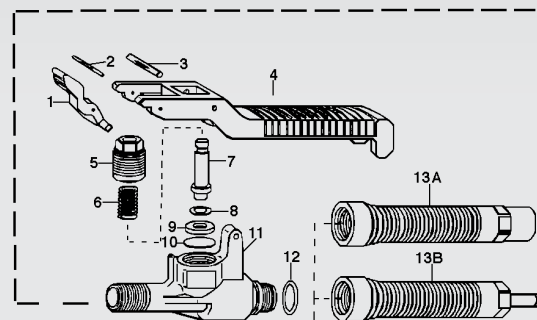
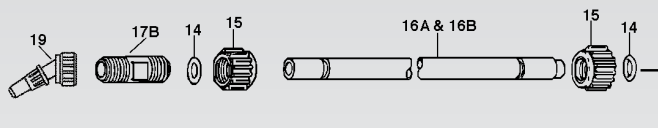

FIMCO Code #	MFG Part #	Extension Length	List Price
5163040	22650-PP-1/4	Without Extension	\$ 31.88
5163034	22670-PP-15 1/4	15"	\$ 50.24
5272927	22670-PP-24 1/4	24"	\$ 57.91

Ref #	FIMCO Code #	MFG Part #	Description	List Price	Ref #	FIMCO Code #	MFG Part #	Description	List Price
1	5077031	CP22656-NY	Trigger Lock	\$ 2.17	*14	Available In Kit Only Marked *			
2	5101129	CP22671-IZP	Groove Pin	\$ 1.39	15	5046122	CP22668-PP	Cap, (2 Required)	\$ 1.73
3	5101130	CP22672-IZP	Groove Pin	\$ 1.39	16A	5065039	CP22663-15-FRP	Extension Tube, 15"	\$ 11.33
4	5092007	CP22655-PP	Trigger	\$ 3.82	16B	5065043	CP22663-24-FRP	Extension Tube, 24"	\$ 18.41
5	5108060	CP22658-PP	Spring Retainer		17A	5005187	CP22673-PP	45° Adapter	\$ 2.00
*6	Available In Kit Only Marked *				17B	5005188	CP22664-PP	Straight Adapter	\$ 2.08
7	5132054	CP22657-NY	Stem	\$ 1.98	5065045	22665-15-PP	Extension Tube Sub-Assembly, 15" (Includes 14, 15, 16A, 17A & 17B)	\$ 12.84	
*8	Available In Kit Only Marked *				5065046	22665-24-PP	Extension Tube Sub-Assembly, 24" (Includes 14, 15, 16A, 17A & 17B)qw	\$ 21.38	
9	5016186	CP22659-PP	Washer	\$ 2.59	19	5018312	38720-PPB-X8	Nozzle Assembly	\$ 7.47
*10	Available In Kit Only Marked *				19	5018313	38720-PPB-X18	Nozzle Assembly* (Includes items marked with *)	
11	5002394	CP22651-PP	Body	\$ 9.85					
*12	Available In Kit Only Marked *								
13A	5078133	CP22654-PP	Handle (1/4" NPT (F) Conn. Poly)	\$ 6.35					
13B	5078168	CP22653-1/4-PP	Handle (with 1/4" hose shank Conn.) Poly	\$ 6.35					

PRO SERIES SPRAYERS
UTV SPRAYERS
SPOT SPRAYERS
ATV SPRAYERS
TRAILER SPRAYERS
UTILITY & 3PT SPRAYERS
SKID SPRAYERS & BOOMS
PUMPS
SPRAYER ACCESSORIES
DRY MATERIAL SPREADERS
TRAILER CARTS & AERATORS
SPRAYER COMPONENTS
PARTSLIST BREAKDOWNS

GUNJET HAND GUNS & ADJUSTABLE TIPS

GUNJET NO. AA23L-7676

Maximum Pressure 250 PSI 23L-7676 with choice of 8", 18", 24", 36", and 48" Extensions Shut-Off Seat At Spray Tip End. Valve needle extends through length of extension

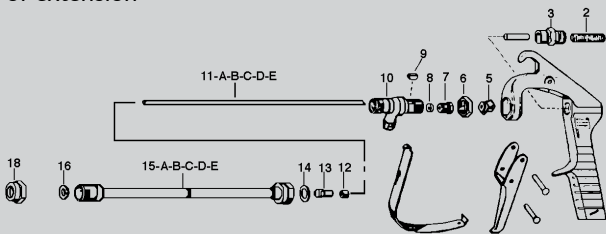

FIMCO Code #	MFG Part #	Extension Length	List Price
5163031	AA23L-7676-8"	Gunjet w/ 8" Extension	\$ 116.78
5163026	AA23L-7676-18"	Gunjet w/18" Extension	\$ 124.50
5163027	AA23L-7676-24"	Gunjet w/24" Extension	\$ 131.96
5163028	AA23L-7676-36"	Gunjet w/36" Extension	\$ 142.60
5163030	AA23L-7676-48"	Gunjet w/48" Extension	\$ 169.81

*Price of Gun Does Not Include 5500 Tip as Shown In Picture. Order 5500 Tip, separately, as shown on the bottom of this page.

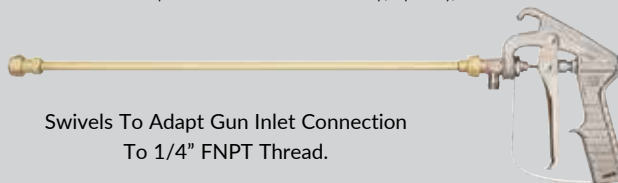

Swivels To Adapt Gun Inlet Connection To 1/4" FNPT Thread.

Ref #	FIMCO Code #	MFG Part #	Description	List Price
*2	Available In Kit Only		Spring, 302 Stainless Steel	
3	5117065	CP7480-IZP	Spring Screw	\$ 5.64
5	5077029	CP8591-IZP	Trigger Guide	\$ 2.12
6	5006065	CP7486-IENP	Locknut, Steel Zinc Plated	\$ 5.27
7	5117137	CP16071-NP	Packing Screw	\$ 3.75
*8	Available In Kit Only		Cup Packing Buna-N	\$ 12.57
9	5089030	CP7892-IZP	Key	\$ 3.45
10	5002356	CP16052-NP	Inlet Body, Brass Nickel Plated	\$ 25.93
11A	5132040	CP7677-8-SS	Stem, Stainless Steel (For 8" Extension)	\$ 24.69
11B	5132041	CP7677-18-SS	Stem, Stainless Steel (For 18" Extension)	\$ 30.51
11D	5132043	CP7677-36-SS	Stem, Stainless Steel (For 36" Extension)	\$ 53.85
11E	5132044	CP7677-48-SS	Stem, Stainless Steel (For 48" Extension)	\$ 70.85
12	5132045	CP7679-1	Stem Guide	
*13	Available In Kit Only		Stem end, brass	
14	5072272	CP4743-TEF	Gasket Teflon	\$ 6.27
15A	5065014	7715-8	Extension, Brass (For 8" Length) Extension Assembly,	\$ 13.61
	5065030	13206-8	Brass (Incl. Items 11A, 12, 13, 14, & 15A) For 8" Length	\$ 45.05
15B	5065015	7715-18	Extension, Brass (For 18" Length) Extension Assembly,	\$ 17.14
	5065031	13206-18	Brass (Incl. Items 11B, 12, 13, 14, & 15B) For 18" Length	\$ 53.62
15C	5065016	7715-24	Extension, Brass (For 24" Length) Extension Assembly,	\$ 18.51
	5065032	13206-24	Brass (Incl. Items 11C, 12, 13, 14, 15C) For 24" Length	\$ 63.10
15D	5065018	7715-36	Extension, Brass (For 36" Length) Extension Assembly,	\$ 23.43
	5065033	13206-36	Brass (Incl. Items 11D, 12, 13, 14, & 15D) For 36" Length	\$ 80.06
15E	5065019	7715-48	Extension, Brass (For 48" Length) Extension Assembly,	\$ 28.38
	5065034D	13206-48	Brass (Incl. Items 11-E, 12, 13, 14, & 15E) For 48" Length	\$ 99.62
*16	5115025	CP7490-BRTF	Valve Seat Teflon	\$ 6.59
18	5046043	CP1325-NP	Cap, Brass Nickel Plated	\$ 2.60
*	5168244	AB23L-7676 -KIT	Spare Parts Kit Items Marked *	\$ 19.82
19	5057086	11990-10	Swivel 1/4 NPS x 1/4 FNPT Female	\$ 19.57
20	5010101		Connector 1/4 NPS x 1/4 FNPT (Does Not Swivel When Tight)	\$ 6.30

ADJUSTABLE TIPS NO. 5500

Adjustable ConeJet Tip No.	Performance	Liquid Pressure in PSI											
		20 PSI Setting		30 PSI Setting		40 PSI Setting		60 PSI Setting		100 PSI Setting		60 PSI Setting	
		A	B	A	B	A	B	A	B	A	B	A	B
5500-X2	Capacity-GPM	.025	.091	.03	.11	.033	.13	.04	.16	.05	.20	.058	.25
	Spray Angle	40°	—	60°	—	68°	—	75°	—	80°	—	83°	—
	Max. Throw Ft.	1.5	23	1.5	26	2	27	2	28	2	28	2	28
5500-PPB-X3	Capacity-GPM	.037	.13	.045	.17	.05	.19	.058	.23	.073	.30	.088	.37
	Spray Angle	57°	—	68°	—	72°	—	76°	—	80°	—	82°	—
	Max. Throw-Ft.	2	27	2	30	2	31	2	31	3	31	3	31
5500-X5	Capacity-GPM	.061	.21	.076	.26	.082	.30	.10	.37	.13	.48	.15	.58
	Spray Angle	61°	—	70°	—	74°	—	77°	—	80°	—	81°	—
	Max. Throw-Ft.	2.5	31	2.5	34	3	35	3	35	3	35	3	35
5500-X8	Capacity-GPM	.097	.33	.12	.40	.13	.47	.16	.57	.21	.74	.25	.90
	Spray Angle	66°	—	71°	—	74°	—	77°	—	80°	—	80°	—
	Max. Throw-Ft.	3	34	3	37	3	38	3	38	4	38	4	38

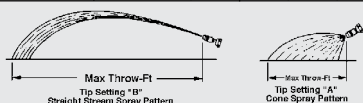

POLYPROPYLENE OR BRASS



Adjustable ConeJet Tips fit standard TeeJet Spray Nozzle body. Body of No. 5500 rotates for spray selection from wide angle cone to straight stream. For capacities from .02 to .04 GPM at 40 p.s.i.

FIMCO Code #	MFG Part #	Description	List Price
5138543	5500-X2	Brass Adjustable Tip	\$ 22.20
5138544	5500-X3	Brass Adjustable Tip	\$ 22.20
5138564	5500-PPB-X3	Polypropylene Adjustable Tip	\$ 10.12
5138545	5500-X5	Brass Adjustable Tip	\$ 22.20
5138565	5500-PPB-X5	Polypropylene Adjustable Tip	\$ 10.12
5138453	5500-X8	Brass Adjustable Tip	\$ 22.20
5138566	5500-PPB-X8	Polypropylene Adjustable Tip	\$ 10.12
5138659	5500-X18	Brass Adjustable Tip	\$ 22.20
5138654	5500-PPB-X18	Polypropylene Adjustable Tip	\$ 10.12
5138661	5500-X26	Brass Adjustable Tip	\$ 22.20

SPRAY GUNS & SHUT-OFF VALVES

Top quality hand valves for use with spray nozzles, extensions and handles to suit your application needs. Hand valve assemblies may be made from parts shown on this page. The "typical assembly" shown at right includes 4727 handle, 4688 valve, 4673-8 curved extension with swivel body, TeeJet cap and flat spray tip.

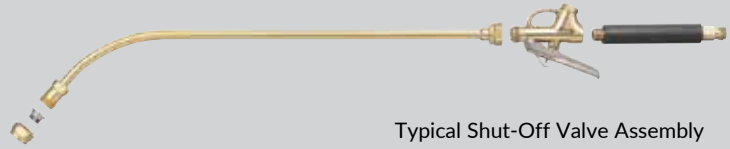

Typical Shut-Off Valve Assembly

TRIGGERS FOR SPRAY GUNS

	FIMCO Code #	MFG Part #	Description	Connection		Max Flow	Max Press	List Wt.	List Price
				In	Out				
	5143152	4688	Trigger Valve w/lock	1/4 FIPT	Tee Jet Cap	2 GPM	250	5 oz	\$ 54.13
	5143153	6466	Same as 4688 less Trigger lock w/extra long Handle	1/4 FIPT	Tee Jet Cap	2 GPM	250	5 oz	\$ 58.35
	5143154	6104	Trigger Valve w/lock	1/4 FIPT	1/4 FIPT	2 GPM	250	5 oz	\$ 53.63
	5143174	6590	Trigger Valve less lock	1/4 FIPT	1/4 FIPT	2 GPM	250	5 oz	\$ 54.47
	5143155	AA36-1/4	Trigger Valve w/lock	1/4 FIPT	1/4 FIPT	7 GPM	150	13 oz	\$ 79.64
	5143216	AA36-3/8	Trigger Valve w/lock	3/8 FIPT	3/8 FIPT	7 GPM	150	13 oz	\$ 79.64

VALVE HANDLES

CHOICE OF VALVE HANDLES-for above valves. Outlet connections are 1/4" NPT(M) to fit 1/4" NPT (F) inlets of all valves shown. Choice of types for every need.

	5078102	4727	Brass Rubber Covered	1/4 MNPS	1/4 MIPT	4 1/4 oz.	\$ 13.65
	5078103	4754	Brass Rubber Covered	3/4 FGHT	1/4 MIPT	5 1/4 oz.	\$ 18.35
	5078152	4725	1/8" Brass Pipe w/ Bushing Slip Hose over Pipe to form Handle	3/8" OD	1/4 MIPT	1 1/2 oz.	\$ 11.84

EXTENSIONS & POLYPROPYLENE SPRAY GUNS

EXTENSIONS FOR SPRAY GUNS



FIMCO Code #	MFG Part #	Extension Length	List Price
5065014	7715-8	8"	\$ 13.61
5065015	7715-18	18"	\$ 17.14
5065016	7715-24	24"	\$ 18.51
5065017	7715-30	30"	\$ 22.20
5065018	7715-36	36"	\$ 23.43
5065019	7715-48	48"	\$ 28.38



CURVED WITH SWIVEL BODY (Pressure to 125 PSI)			
FIMCO Code #	MFG Part #	Extension Length	List Price
5065008	4673-8	8"	\$ 22.77
5065009	4673-18	18"	\$ 26.49
5065010	4673-24	24"	\$ 27.82
5065011	4673-30	30"	\$ 30.62
5065012	4673-36	36"	\$ 32.75
5065013	4673-48	48"	\$ 37.49

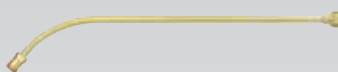

CURVED WITH FIXED BODY (Pressure to 250 PSI)			
FIMCO Code #	MFG Part #	Extension Length	List Price
5065002	6671-8	8"	\$ 15.90
5065003	6671-18	18"	\$ 19.39
5065004	6671-24	24"	\$ 20.02
5065005	6671-30	30"	\$ 22.64
5065006	6671-36	36"	\$ 25.76
5065007	6671-48	48"	\$ 29.79



CURVED WITH HIGH PRESSURE (Pressure to 1000 PSI)			
FIMCO Code #	MFG Part #	Extension Length	List Price
5065020	9527-8	8"	\$ 42.86
5065021	9527-18	18"	\$ 49.60
5065022	9527-24	24"	\$ 50.82
5065023	9527-36	36"	\$ 65.88
5065024	9527-48	48"	\$ 71.28

STRAIGHT WITH FIXED BODY (Pressure to 250 PSI)

4673- for pressures to 125 P.S.I. 6671- & 7715- for pressures to 250 psi Fits Models 23L, 31 GunJet spray Guns and trigger valves. Designed for use with TeeJet strainers, caps, and spray tips.

Use when spraying pressures will be greater than 250 P.S.I. Fits models 23H and 31 GunJet Spray Guns. Body designed for use with TeeJet strainers, caps and spray tips. Fixed position body, brass constructed with rubber covered handle (except in 8" length). Warning: Do not use at pressure higher than those specified for valve or spray gun.

TRIGGERJET POLYPROPYLENE SPRAY GUNS

AA30L-PP

- Inlet Is 1/4" FIPT
- Flow Rates to 5 G.P.M.
- Maximum Pressure 150 P.S.I.
- Wetted Parts Are Polypropylene
- Stainless Steel and Viton



AA30L-PP-15

w/15" Extension and Adjustable ConeJet Tip

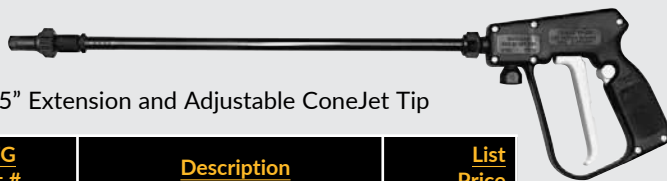

MFG Part #	Description	List Price
AA30L-PP	Without Extension or Tip	\$ 59.87
AA30L-PP-15	W/ 15" Extension & Adj. Tip	\$ 78.73

5273959 PISTOL GRIP HANDGUN

- Flow Rates Up to 5 G.P.M.; 300 P.S.I.
- Comfortable Pistol Grip Handgun
- 18" Aluminum Wand
- Adjustable Pattern Tip (Cone to Straight Stream)



MFG Part #	Description	List Price
5273959	Handgun w/X-26 Tip	\$ 35.88
5018331	X-26 Tip Only (Brass)	\$ 9.14

HIGH PRESSURE SPRAY GUNS & WANDS

AA23H GUNJET SERIES SPRAY GUN

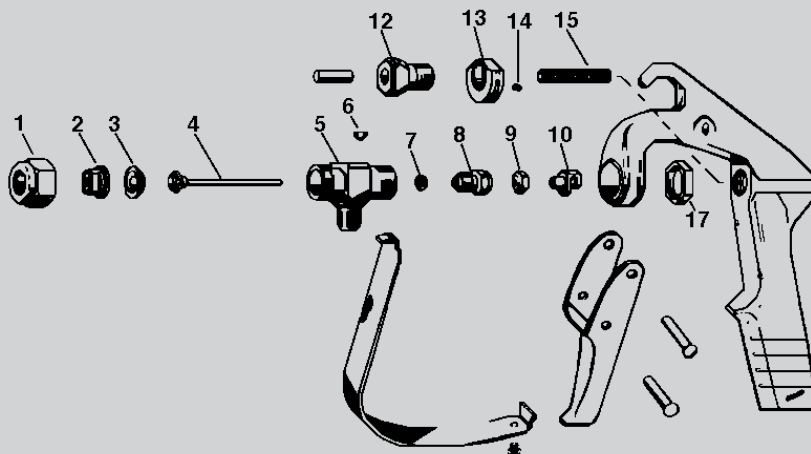
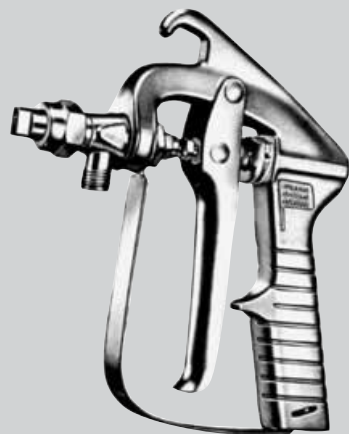

Instant shut-off with valve seat directly behind orifice tip. Use with any TeeJet Tip and with low and high pressure. Flow rates to 5 GPM. With comfortable trigger grip. Trigger guard helps prevent accidental discharge. Trigger lock holds trigger in "off" position. 1/4" NPS (M) inlet connection.

NOTE:

Slide #14255-1 cup packing onto stem before inserting packing completely into inlet body, making sure cupped side of packing is facing inlet body.

How To Install #7490 - Valve Seat And Replace #14255 - 1 Cup Packing

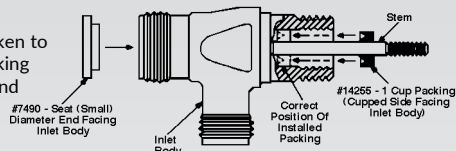

CAUTION:

Extra care should be taken to prevent damage to packing from threads on stem and inlet body.

FIMCO Code #	MFG Part #	Description	List Price
5271814	AA23H	Gunjet w/Cap less tip	\$ 80.84

Ref #	FIMCO Code #	MFG Part #	Description	List Price
1	5046082	CP7890-NP	Cap Brass - I.N.P.	\$ 9.47
2			Spray Tip (Order By No.)	
*3	5115025	CP7490-BRTF	Valve Seat, Teflon	\$ 6.59
*4	Available In Kit Only		Main Stem Assembly	
5	5002356	CP16052-NP	Inlet Body	\$ 25.93
6	5089030	CP7892-I ZP	Key	\$ 3.45
*7	Available In Kit Only		Packing Cup	
8	5117137	CP16071-NP	Packing Screw	\$ 3.75
9	5006064	CP7484-SS	Stem Nut	\$ 3.60
10	5077009	CP7481-INP	Trigger Guide	\$ 13.21
12	5117138	CP9421-INP	Safety Lock	\$ 9.30
13	5045010	CP39698-NY	Safety Lock Cam	\$ 11.55
14	5117139	CP9423-I	Set Screw	\$ 3.35
*15	Available In Kit Only		Main Spring	
17	5006065	CP7486-IENP	Lock Nut	\$ 5.27
	5168238	PK-AB23H-KIT	Repair Kit Marked*	\$ 27.02
	5010101		Swivel - 1/4FNPT x 1/4FNPS (Does Not Swivel After Tight)	\$ 6.30
	5057086	11990-10	Swivel 1/4FNPT x 1/4FNPS	\$ 19.57

NO. AA31 GUNJET

For flow rates up to 5 GPM. No. 31 for pressures up to 500 P.S.I. Comfortable palm fitting gun. For use with any TeeJet spray tip. 1/4" NPS (M) inlet connection.

FIMCO Code #	MFG Part #	Description	List Price
5163015	AA 31	Gun, Less Tip	\$ 84.67
5163016	*AA 31TL	Gun, Less Tip	\$ 76.67
	PK-AB31-KIT	Kit	\$ 20.46

*Trigger Lock Included

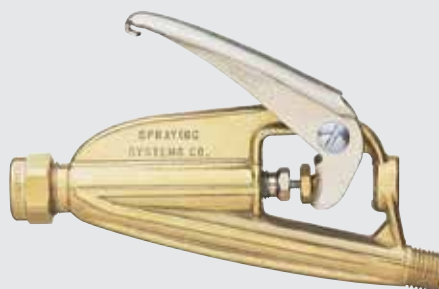











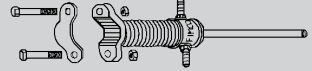

SWIVELS FOR GUN CONNECTIONS

Ref #	FIMCO Code #	Description	List Price
1	5057086	(11990-10)1/4" FNPS x 1/4 FNPT Female Brass Swivel	\$ 19.57
2	5010101	Connector 1/4" FNPS x 1/4" FNPT Female (Does Not Swivel after tight)	\$ 6.30



DROP PIPES & SWIVELS

Drop Pipes are Nylon or Aluminum Pipe with 1/4" Male Pipe Thread on lower end. Attachment fitting type and sizes are listed below.

	FIMCO Code #	MFG Part #	Description	List Price
 1/4" MIPT Male Connection	5056032	11-D	16" Male Aluminum Drop Pipe	\$ 23.31
	5056033	20-D	20" Male Aluminum Drop Pipe	\$ 37.15
 11/16" - 16 F Nozzle Cap Connection	5056034	12-D	16" Female Aluminum Drop Pipe	\$ 30.87
	5056035	21-D	20" Female Aluminum Drop Pipe	\$ 83.17
 11/16" - 16 F Nozzle Cap Connection	5065053	21354-15-NYB	15" Female Nylon Drop Pipe	\$ 8.98
 Quick TeeJet Nozzle Cap Connection	5056134	21353-6-15-NYB	15" QuickTeeJet Nylon Hose Drop	\$ 13.59
	5056135	21353-6-24-NYB	24" QuickTeeJet Nylon Hose Drop	\$ 13.59
 Clamp Fits 7/8", 1", & 1-5/16" Round Tubing, 1-1/4" & 1-1/2" Sq. Tubing, & 2" Diamond Bar. 1/2" Hose Connection.	5056133		16" Heavy Duty Spring Loaded Drop Pipe	\$ 110.45
	5002180	8600-2-1/4T-NYB	Nylon Double Swivel, Less Cap & Tip	\$ 11.72
	5002442	QJ8600-2-1/4-NYB	QuickJet Double Swivel	\$ 10.07
	5002326	7620-T	1/4" Brass Single Swivel Less Cap & Tip	\$ 29.64
	5002349	8600-1/4T-NYB	1/4" Nylon Single Swivel Less Cap & Tip	\$ 9.70
	5002441	QJ8600-1/4-NYB	QuickJet Single Swivel	\$ 8.37
	5002439	QJ1/4T-NYB	Adaptor 1/4" FIPT Adapts to Quick Jet Caps	\$ 3.14
	046186	19843-NYR	QuickJet Shutoff Cap	\$ 2.56
	5005074	4676-1/4	1/4" Brass Adapter (Has same thread as- Nozzle Cap)	\$ 3.21
	5005073	4676-1/8	1/8" Brass Adapter (Nozzle Cap)	\$ 3.21
 TWIN ORIFICE TIPS *For Rate Charts See Page 113		TQ150-0*	Double-Outlet Tip, Brass	\$ 10.38
			TQ150-0*-SS	Double-Outlet Tip, Stainless Steel

TANK ACCESSORIES

HYPRO JET AGITATOR

Jet action increases pump output as much as 3 and 4 times. Delivers volume needed for effective agitation of spray tanks to keep spray materials from settling out. Low pressure unrestricted discharge reduces foaming. Complete with three sizes of interchangeable nozzles that permit control of discharge. Tough, special formula nylon construction. Inlet is 1/2 inch NPT (female) outlet is 3/4 inch NPT (male).

FIMCO Code #	MFG Part #	Description	List Price
5014005	3371	3/4" NPT (M) Out 1/2" NPT (F) in	\$ 6.40
5014014	3371-0019	3/4" NPT (M)	\$ 7.31
5010258	3R12	1/2" NPT (M) Poly Tee	\$ 4.72
High Volume Jet Agitator			
	3371-0028	3/4" NPT (M)	\$ 46.00

*INCLUDES BODY, SPACER RING, & 3 NOZZLES (1 EACH OF 3 SIZES)



JET AGITATOR

Agitator Mounts in bottom of 3/4" Tank Fitting. Additional 3/4" Thread protrudes to attach Female Pipe Coupling or Hose Barb to Agitator. For larger tanks, extra agitator may also be mounted in End Tank Fitting, to obtain Dual Agitation.

FIMCO Code #	Description	List Price
5014011	3/4" Polypropylene Agitator	\$ 8.97
5010220	3/4" FNPT x 1/2 HB Poly Elbow	\$ 3.15
5010114	3/4" FNPT x 1/2 HB Nylon Elbow	\$ 3.42
5010221	3/4" FNPT x 3/4 HB Poly Elbow	\$ 4.91
5010136	3/4" FNPT x 3/4 HB Nylon Elbow	\$ 3.56

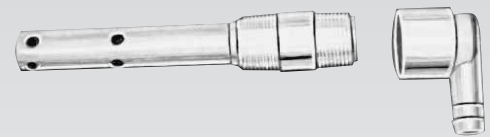

EDUCTOR NOZZLE (AGITATOR)

- Allows small pumps to circulate large volumes of liquid.
- Manufactured of glass filled polypropylene for excellent corrosion and chemical resistance.
- Large flow opening minimizes plugging

FIMCO Code #	MFG Part #	Description	List Price
5014015	Y33180-PP	3/8" Agitator-9 GPM Inlet Flow	\$ 70.31
5014016	Y9270-PP	3/4" Agitator-13.5 GPM Inlet Flow	\$ 70.31



FIMCO Code #	MFG Part #	Description	List Price
5133207	F12512	2" Poly Tank Strap (Per Foot)	\$ 1.29
5133220	F12841	3" Poly Tank Strap (150 Ft. Roll - Sold In Full Rolls Only)	\$ 1.89
5108041	FI 8041	Buckle (Bent) for 1-3/4" Tank Strap	\$ 6.46
5108042	FI 8042	Buckle (Straight) for 1-3/4" Tank Strap	\$ 2.44
5108112	FI 8112	Buckle (Bent) for 3" Tank Strap	\$ 5.68
5108111	FI 8111	Buckle (Straight) for 3" Tank Strap	\$ 6.00
5034298	FI 4298	Hook Bolt 3/8 x 6"	\$ 4.18
5034111	FI 4111	Hook Bolt for Buckle 1/2" x 6"	\$ 4.23

PRO SERIES SPRAYERS
UTV SPRAYERS
SPOT SPRAYERS
ATV SPRAYERS
TRAILER SPRAYERS
UTILITY & 3PT SPRAYERS
SKID SPRAYERS & BOOMS
PUMPS
SPRAYER ACCESSORIES
DRY MATERIAL SPREADERS
TRAILER CARTS & AERATORS
SPRAYER COMPONENTS
PARTS LIST BREAKDOWNS

TANK REPAIR PARTS

SOLAR PLASTICS TANK PARTS

FIMCO Code #	MFG Part #	Description	Hole Size In Tank	List Price
--------------	------------	-------------	-------------------	------------

Fittings for Solar Tanks



5271585	SP37044	Complete 3/4" Double Threaded Fitting For Poly Tank	1-3/8"	\$ 26.69
5271690	SP37113	Complete 1-1/4" Double Threaded Fitting For Poly Tank	2"	\$ 32.82
5271752	SP37071	Complete 2" Double Threaded Fitting For Poly Tank	3"	\$ 86.15
5275014	10058	1/2" Ace Bulkhead Fitting	1-1/4"	\$ 7.70

Gaskets for Solar Polyethylene Tanks



5016128	SP37151	Gasket, EPDM For 3/4" Fitting For Poly Tank		\$ 6.36
5016131	SP37085	Gasket, EPDM For 1-1/2" & 2" Fitting For Poly Tank		\$ 7.59

Lids for Solar Polyethylene Tanks



5058090	SP37142	5" Screw Type Lid (for 25 Gal Solar Tank)		\$ 25.23
5072494	SP37218	5" Lid Gasket		\$ 11.52

Lids for FIMCO Sprayer Tanks



5058188		5" Screw Type Lid (10, 15, 20, 25, 30, 35, 40, 55, 60 Gal. Tanks)		\$ 10.98
	10525	8" Screw Type Lid w/Air Breather		\$32.78
5058170		Tether Only For 5058188 Lid		\$ 1.13

Threaded Lids for Solar Tanks



5058122	SP37426	10" Polyethylene Tank Lid (Threaded Lid For Solar Tank)		\$ 72.83
5110271	SP37427	10" Polyethylene Tank Lid Fillwell Ring (Threaded Solar Lid Above)		\$ 44.58

Snyder Fittings

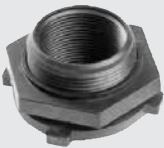

5010286	SNW340001	Complete 3/4" Single Threaded Fitting For Poly Tank	2-1/4"	\$ 16.57
5010287	SN340002	Complete 1" Single Threaded Fitting For Poly Tank	2-1/4"	\$ 16.82
5010288	SN340003	Complete 1-1/4" Single Threaded Fitting For Poly Tank	2-1/4"	\$ 23.10
5010289	SN340004	Complete 1-1/2" Single Threaded Fitting For Poly Tank	2-1/4"	\$ 24.01

Snyder Gaskets



5072463	SN331040	EPDM "O" Ring For All Snyder Fittings Above		\$ 6.90
---------	----------	---	--	---------

Lids for Snyder Tanks



5058144	SN343080	10" Threaded Lid - Female Thread		\$ 76.25
5058148	SN343047	6" Threaded Lid		\$ 55.73

PRO SERIES SPRAYERS
UTV SPRAYERS
SPOT SPRAYERS
ATV SPRAYERS
TRAILER SPRAYERS
UTILITY & 3PT SPRAYERS
SKID SPRAYERS & BOOMS
PUMPS
SPRAYER ACCESSORIES
DRY MATERIAL SPREADERS
TRAILER CARTS & AERATORS
SPRAYER COMPONENTS
PARTS LIST BREAKDOWNS

REPAIR PARTS: LG-15-EC & LG-25-EC

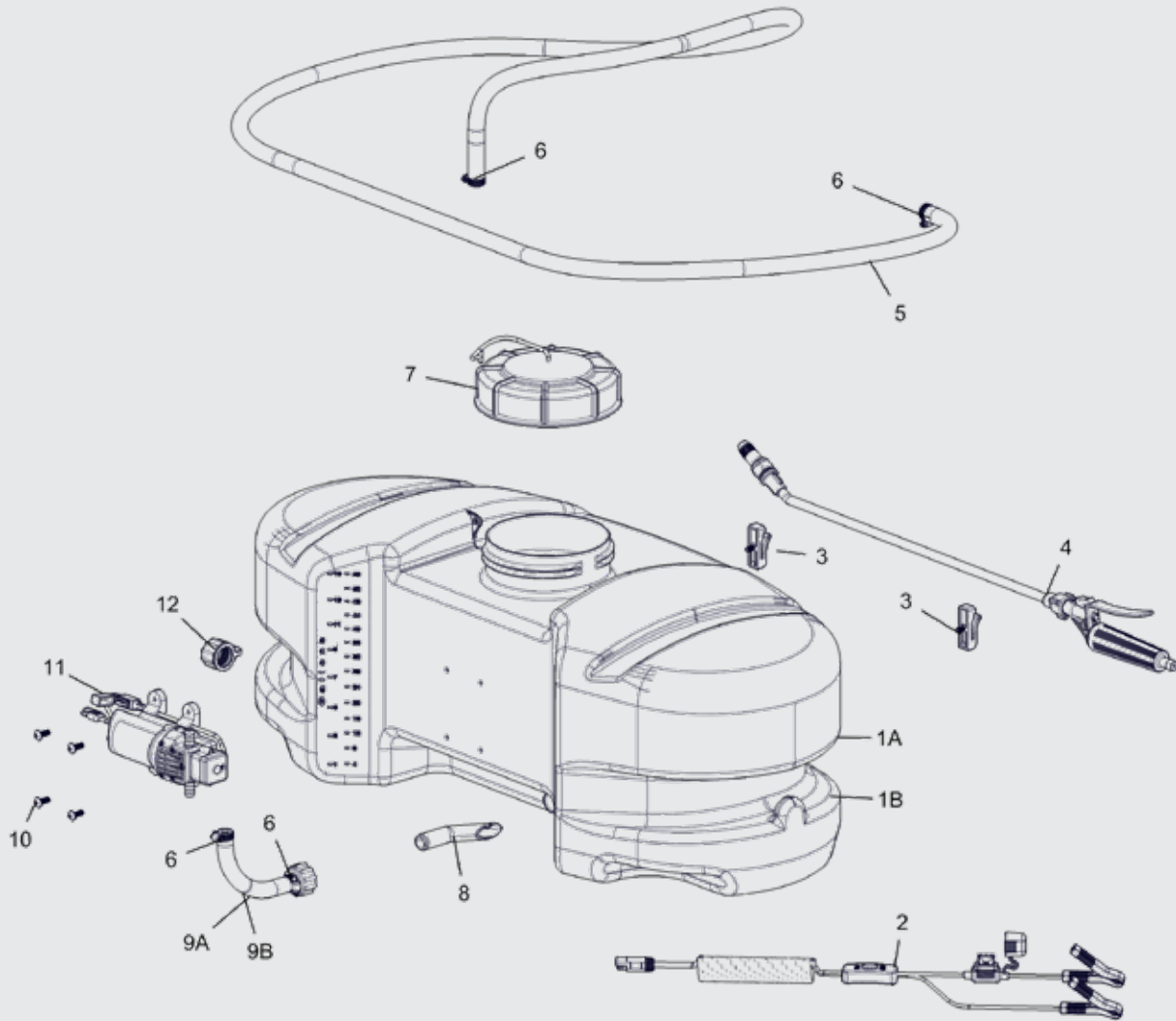

Ref. #	Part #	Description	Qty
1A	5169242	15 Gallon Tank (White) (LG-15-EC)	1
1B	5169243	25 Gallon Tank (White) (LG-25-EC)	1
2	5278017	Lead Wire Assembly w/5A Fuse & 30A Clips (96" Long)	1
3	5274880	Handgun Clips & Screws (Pkg/2) (#10-24 Thread)	1
4	5163100	Low-Flow Spray Wand w/X-26 Tip	1
5	5020524	Hose, 3/8"-1 Brd. x 15 Ft.	1
6	5051144	Hose Clamp, 3/8"	4
7	5058188	Tank Lid w/Lanyard	1
8	5100452	Siphon Tube	1
9A	5275511	Inlet Sub-Assembly (LG-15-EC)	1
9B	5275526	Inlet Sub Assembly (LG-25-EC)	1
10	5117167	#10-24 x 5/8" Phillips Truss Head Machine Screw	4
11	5277980	High Flo Gold Series 1.0 GPM Pump	1
12	5274373	Drain Plug Cap, Tether, and Washer Assembly	1

REPAIR PARTS: LG-14-PM & LG-14-SM & LG-25-PM & LG-25-SM

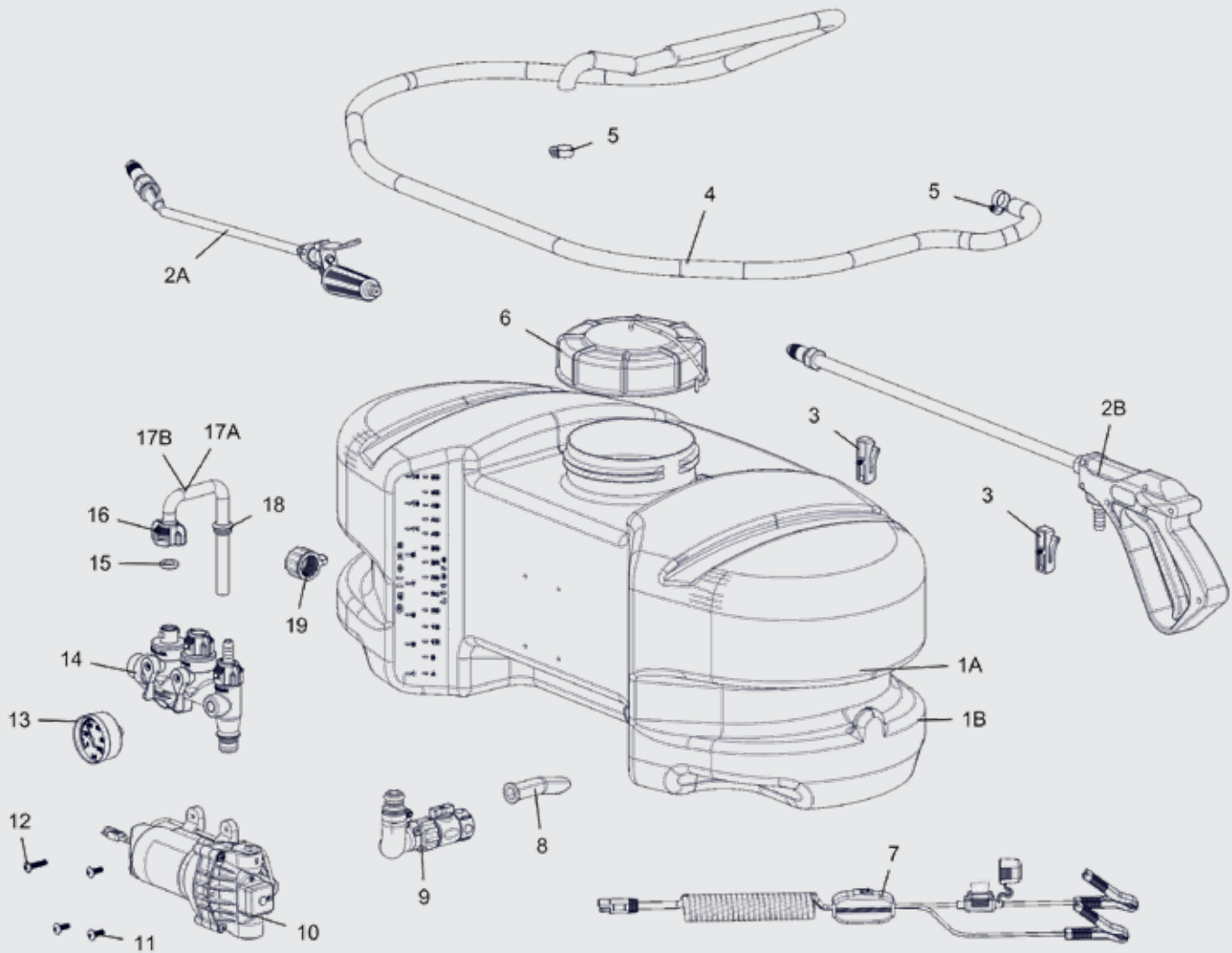

Ref. #	Part #	Description	Qty
1A	5169242	15 Gallon Tank (White) (LG-14-PM & LG-14-SM)	1
1B	5169243	25 Gallon Tank (White) (LG-25-PM & LG-25-SM)	1
2A	5163100	Sprayer Handgun w/X-26 Tip (LG-14-PM & LG-25-PM)	1
2B	5273959	Pistol-Grip Handgun w/X-26 Tip (LG-14-SM & LG-25-SM)	1
3	5274880	Handgun Clips & Screws (Pkg/2) (#10-24 Thread)	1
4	5020524	Hose, 3/8"-1 Brd. x 15 Ft.	1
5	5051144	Hose Clamp - 3/8"	2
6	5058188	Tank Lid w/Lanyard	1
7	5278114	Lead Wire Assembly w/15A Fuse & 30A Clips (96" Long)	1
8	5100452	Siphon Tube	1
9	5275877	Intake Sub-Assembly	1
10	5277981	Gold Series 2.1 g.p.m. Pump (60 psi, 8 amp)	1
11	5117167	#10-24 x 5/8" Phillips Truss Head Machine Screw	3
12	5117168	#10-24 x 1" Truss Head Machine Screw	1
13	5167097	2" Dry 100# Back Mount Pressure Gauge	1
14	5302348	Quick Connect Manifold Assembly	1
15	5143430	Flat Washer - Hose Barb Seal	1
16	5143429	QC Manifold - QC Quarter Turn Cap	1
17A	5100804	Rigid By-Pass Tube Assembly (LG-14-PM & LG-14-SM)	1
17B	5100803	Rigid By-Pass Tube Assembly (LG-25-PM & LG-25-SM)	1
18	5075018	Grommet	1
19	5274373	Drain Plug Cap, Tether, and Washer Assembly	1

PRO SERIES SPRAYERS
UTV SPRAYERS
SPOT SPRAYERS
ATV SPRAYERS
TRAILER SPRAYERS
UTILITY & 3PT SPRAYERS
SKID SPRAYERS & BOOMS
PUMPS
SPRAYER ACCESSORIES
DRY MATERIAL SPREADERS
TRAILER CARTS & AERATORS
SPRAYER COMPONENTS
PARTS LIST BREAKDOWNS

REPAIR PARTS: ATV-15-2-QR

See Page 170 For Boom Parts List

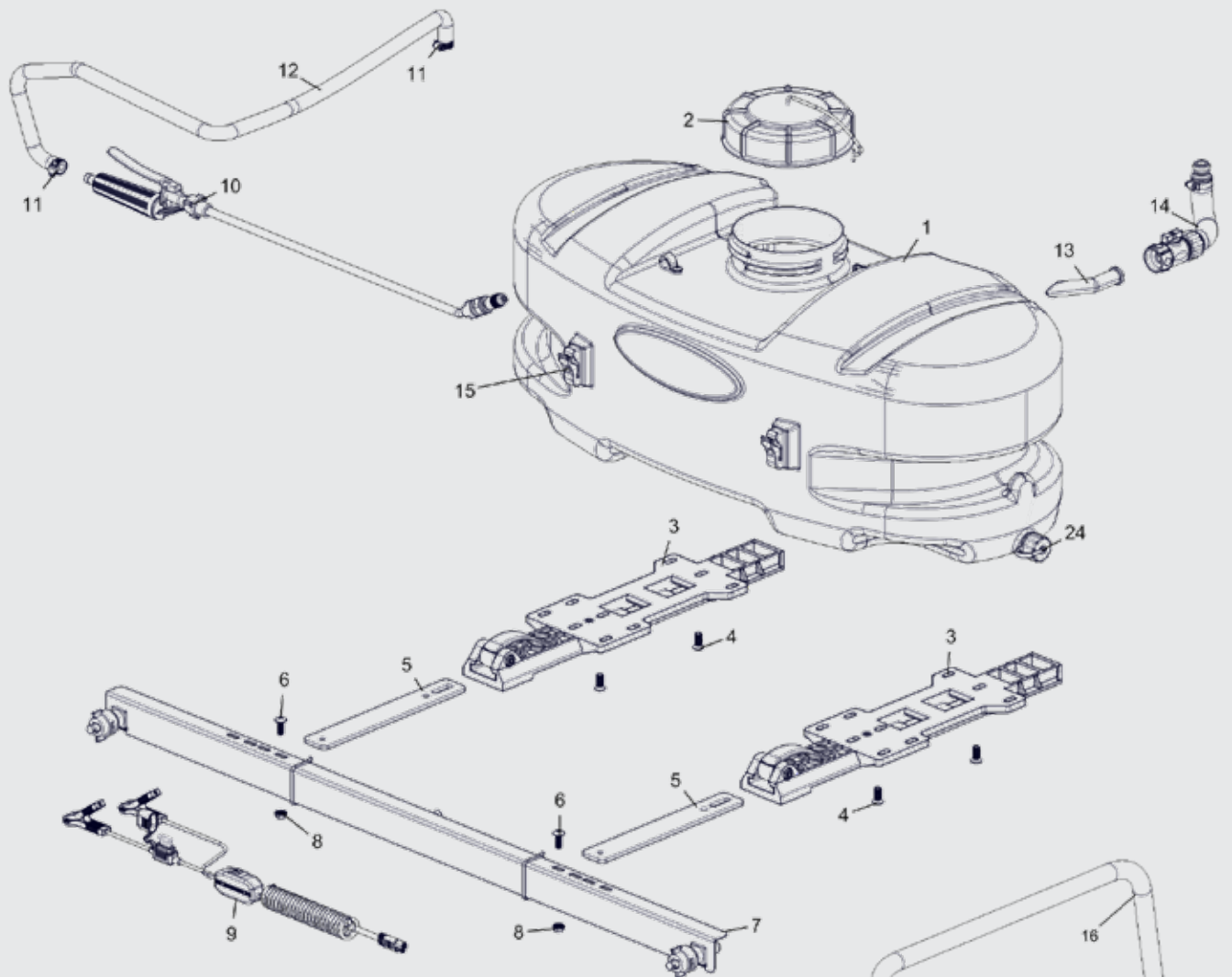

Ref. #	Part #	Description	Qty
1	5169242	15 Gallon Tank (White)	1
2	5058188	Tank Lid w/Lanyard	1
3	5278222	ATV Quick Release Bracket Assembly	2
4	5034149	5/16-18nc x 3/4" lg Flat Head Screw (100) W/Locking Patch	4
5	5038873	Quick Release Boom Mount Bracket - Fixed Height	2
6	5117287	1/4"-20 x 3/4" Phillips Truss Head Machine Screw	2
7	5278237	Rigid 2-Nozzle ATV-15/20 Boom Assembly	1
8	5006306	1/4-20nc Hex Flanged Whiz Nut Gr. 5	2
9	5278114	Lead Wire Assembly w/15A Fuse & 30A Clips (96" Long)	1
10	5163100	Low-Flow Spray Wand w/X-26 Tip	1
11	5051144	Hose Clamp, 3/8"	4
12	5020524	Hose, 3/8"-1 Brd. x 15 Ft.	1
13	5100452	Siphon Tube	1
14	5275877	Intake Sub-Assembly	1
15	5274880	Handgun Clips & Screws (Pkg. 2)	1
16	5020538	Hose, 3/8"-1 Brd. x 43"	1
17	5143430	Flat Washer - Hose Barb Seal	1
18	5143429	QC Manifold - QC Quarter Turn Cap	1
19	5100804	Rigid By-Pass Tube Assembly	1
20	5075018	Grommet, 1/2" I.D.	1
21	5302793	Quick Connect Manifold Assembly	1
22	5167097	2" Dry 100# Back Mount Gauge	1
23	5277981	High Flo Gold Series 2.1 GPM Pump	1
24	5274373	Drain Plug Cap, Tether, and Washer Assembly	1

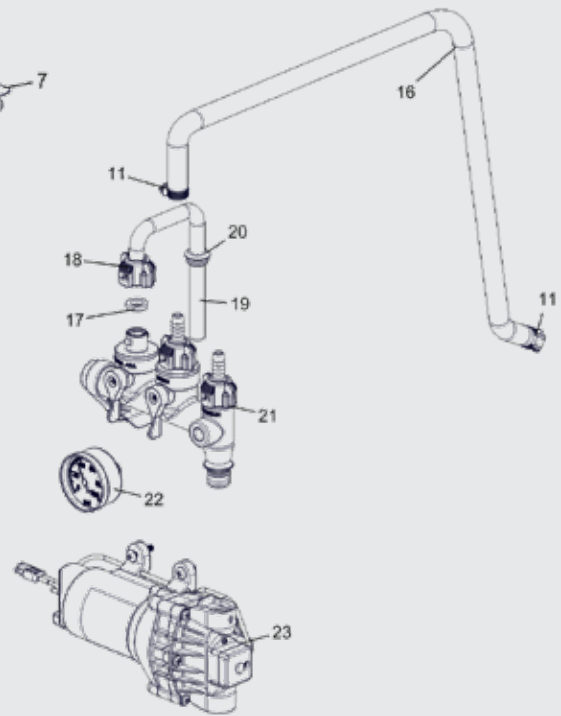

PRO SERIES SPRAYERS
UTV SPRAYERS
SPOT SPRAYERS
ATV SPRAYERS
TRAILER SPRAYERS
UTILITY & 3PT SPRAYERS
SKID SPRAYERS & BOOMS
PUMPS
SPRAYER ACCESSORIES
DRY MATERIAL SPREADERS
TRAILER CARTS & AERATORS
SPRAYER COMPONENTS

REPAIR PARTS: ATV-25-71-QR

PRO SERIES SPRAYERS
 UTV SPRAYERS
 SPOT SPRAYERS
 ATV SPRAYERS
 TRAILER SPRAYERS
 UTILITY & 3PT SPRAYERS
 SKID SPRAYERS & BOOMS
 PUMPS
 SPRAYER ACCESSORIES
 DRY MATERIAL SPREADERS
 TRAILER CARTS & AERATORS
 SPRAYER COMPONENTS
PARTS LIST BREAKDOWNS

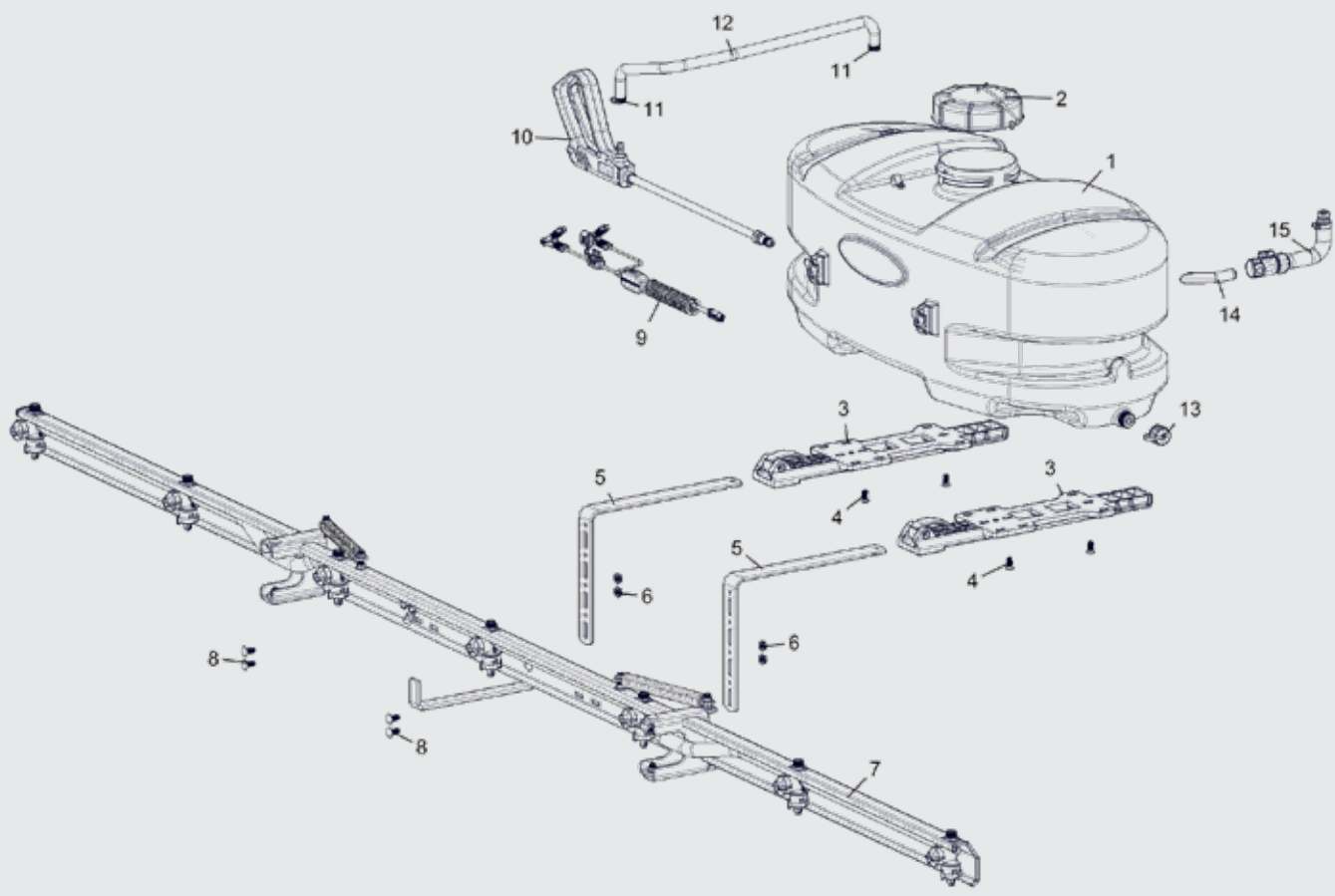

Ref. #	Part #	Description	Qty
1	5169243	25 Gallon Tank (White)	1
2	5058188	Tank Lid w/Lanyard	1
3	5278222	ATV Quick Release Bracket Assembly	2
4	5034149	5/16-18nc x 3/4" Flat Head Screw W/Locking Patch	4
5	5038872	Quick Release Bracket - Bent Adjustable Height	2
6	5006307	5/16"-18 Hex Whiz (Flange) Locknut	4
7	5302485	7-Nozzle Deluxe QR Boom Assembly	1
8	5034578	Carriage Bolt, 5/16"-18 x 3/4" (short neck)	4
9	5278114	Lead Wire Assembly w/15A Fuse & 30A Clips (96" Long)	1
10	5273959	Deluxe Pistol-Grip Handgun w/X-26 Tip	1
11	5051144	Hose Clamp, 3/8"	2
12	5020524	Hose, 3/8"-1 Brd. x 15 Ft.	1
13	5274373	Drain Plug Cap, Tether, and Washer Assembly	1
14	5100452	Siphon Tube	1
15	5275877	Intake Sub-Assembly	1
16	5051114	Hose Clamp, 1/2"	2
17	5020122	Hose, 1/2"-1 Brd. x 48"	1
18	5143430	Flat Washer - Hose Barb Seal	1
19	5143429	QC Manifold - QC Quarter Turn Cap	1
20	5100822	Rigid By-Pass Tube Assembly	1
21	5075018	Grommet, 1/2" I.D.	1
22	5302349	Quick Connect Manifold Assembly	1
23	5167097	2" Dry 100# Back Mount Gauge	1
24	5277982	Hi Flo Gold Series 3.8 GPM Pump	1

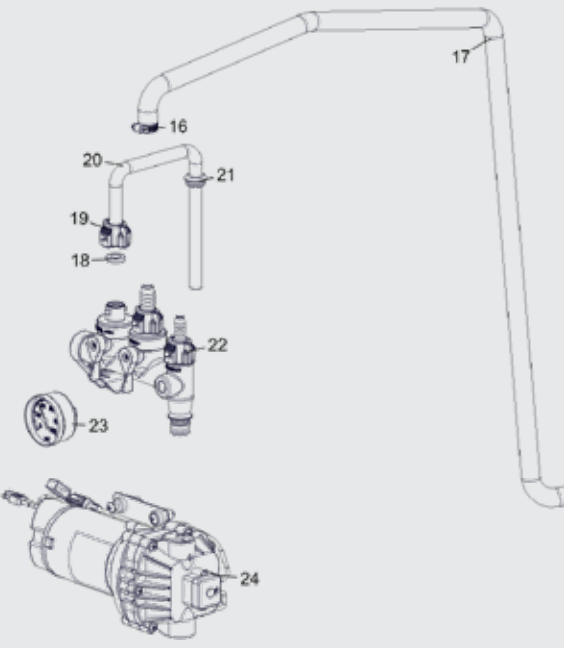

REPAIR PARTS: LG-3025-QR

See Page 171 For Boom Parts List

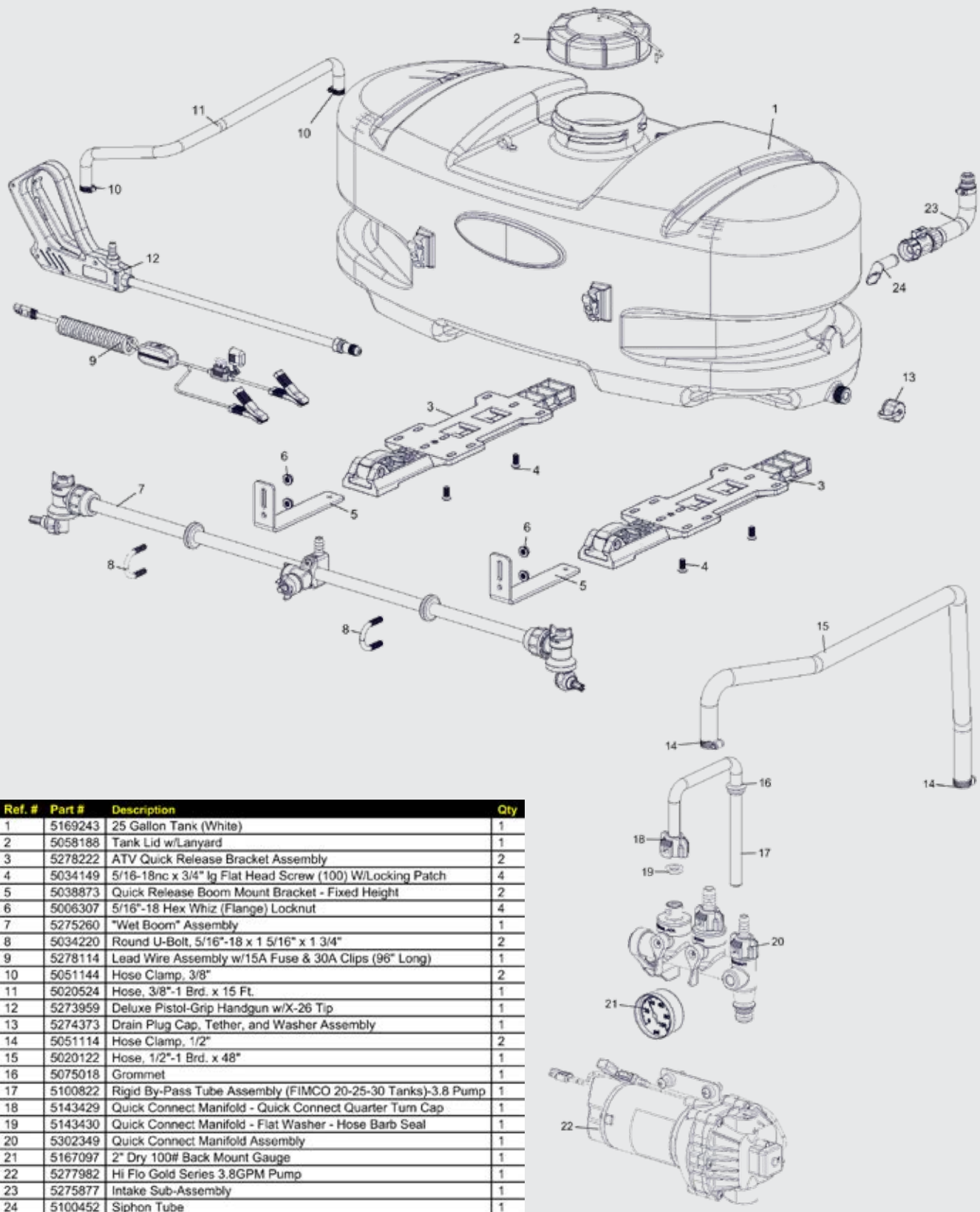

Ref. #	Part #	Description	Qty
1	5169243	25 Gallon Tank (White)	1
2	5058188	Tank Lid w/Lanyard	1
3	5278222	ATV Quick Release Bracket Assembly	2
4	5034149	5/16-18nc x 3/4" lg Flat Head Screw (100) W/Locking Patch	4
5	5038873	Quick Release Boom Mount Bracket - Fixed Height	2
6	5006307	5/16"-18 Hex Whiz (Flange) Locknut	4
7	5275260	"Wet Boom" Assembly	1
8	5034220	Round U-Bolt, 5/16"-18 x 1 5/16" x 1 3/4"	2
9	5278114	Lead Wire Assembly w/15A Fuse & 30A Clips (96" Long)	1
10	5051144	Hose Clamp, 3/8"	2
11	5020524	Hose, 3/8"-1 Brd. x 15 Ft.	1
12	5273959	Deluxe Pistol-Grip Handgun w/X-26 Tip	1
13	5274373	Drain Plug Cap, Tether, and Washer Assembly	1
14	5051114	Hose Clamp, 1/2"	2
15	5020122	Hose, 1/2"-1 Brd. x 48"	1
16	5075018	Grommet	1
17	5100822	Rigid By-Pass Tube Assembly (FIMCO 20-25-30 Tanks)-3.8 Pump	1
18	5143429	Quick Connect Manifold - Quick Connect Quarter Turn Cap	1
19	5143430	Quick Connect Manifold - Flat Washer - Hose Barb Seal	1
20	5302349	Quick Connect Manifold Assembly	1
21	5167097	2" Dry 100# Back Mount Gauge	1
22	5277982	Hi Flo Gold Series 3.8GPM Pump	1
23	5275877	Intake Sub-Assembly	1
24	5100452	Siphon Tube	1

PRO SERIES SPRAYERS
UTV SPRAYERS
SPOT SPRAYERS
ATV SPRAYERS
TRAILER SPRAYERS
UTILITY & 3PT SPRAYERS
SKID SPRAYERS & BOOMS
PUMPS
SPRAYER ACCESSORIES
DRY MATERIAL SPREADERS
TRAILER CARTS & AERATORS
SPRAYER COMPONENTS
PARTS LIST BREAKDOWNS

REPAIR PARTS: LG-1500-303 & LG-2500-303

See Page 170 For Boom Parts List

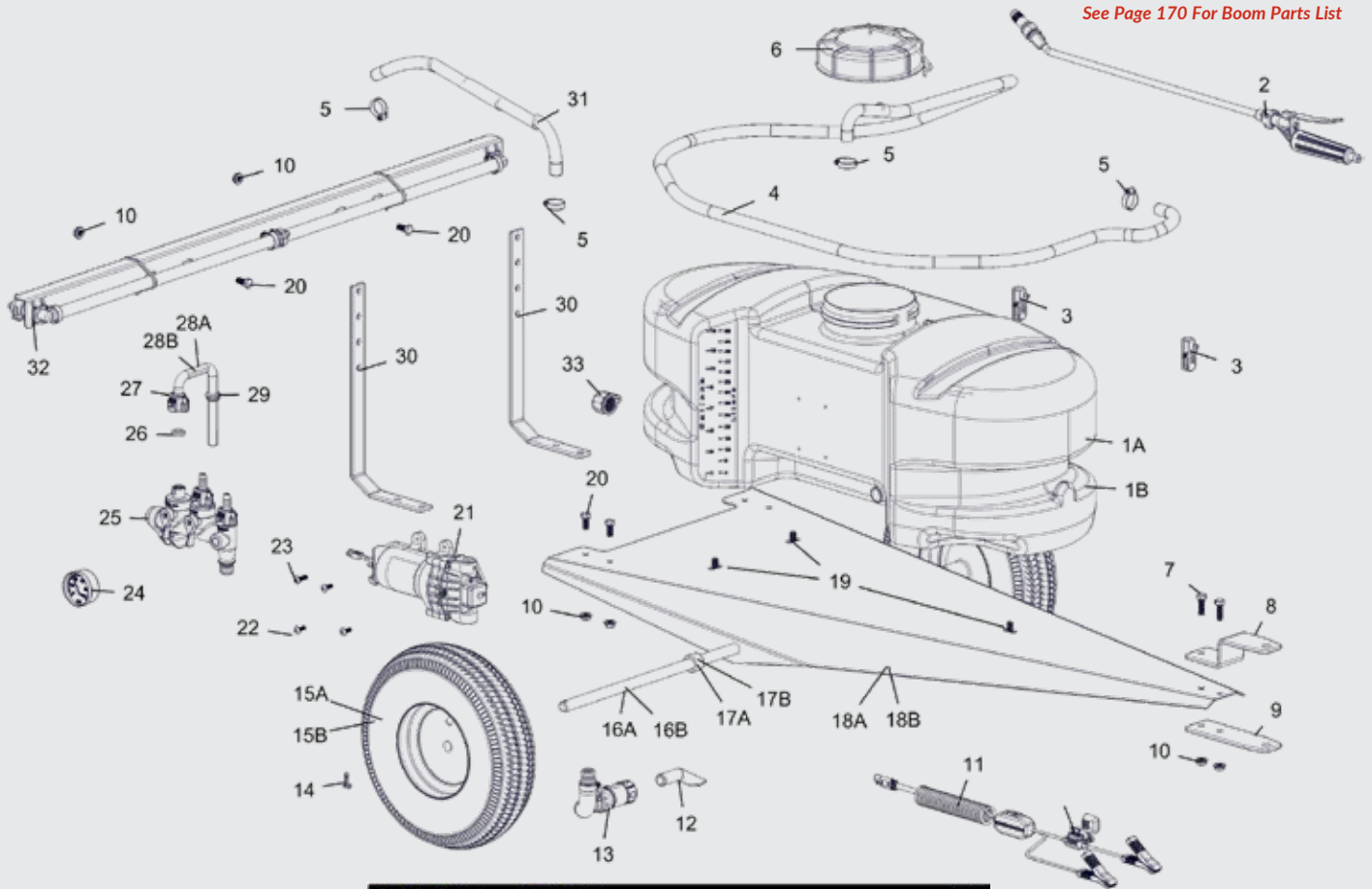

Ref. #	Part #	Description	Qty
1A	5169242	15 Gallon Tank (White) (LG-1500-303)	1
1B	5169243	25 Gallon Tank (White) (LG-2500-303)	1
2	5163100	Sprayer Handgun w/X-26 Tip	1
3	5274880	Handgun Clips & Screws (Pkg/2) (#10-24 Thread)	1
4	5020524	Hose, 3/8"-1 Brd. x 15 Ft.	1
5	5051144	Hose Clamp - 3/8"	4
6	5058188	Tank Lid w/Lanyard	1
7	5117300	H.H.C.S. 5/16"-18nc x 1" Long	2
8	5038517	Hitch Bracket (Formed)	1
9	5038518	Hitch Bracket (Flat)	1
10	5006307	5/16"-18 Hex Whiz (Flange) Locknut	8
11	5278114	Lead Wire Assembly w/15A Fuse & 30A Clips (96" Long)	1
12	5100452	Siphon Tube	1
13	5275877	Intake Sub-Assembly	1
14	5101077	Cotter Pin, 1/8" x 1"	2
15A	5021092	4.10/3.50-4 Wheel (White) (5/8" Bearing) (LG-1500-303)	2
15B	5021102	4.10/3.50-6 Wheel (White) (5/8" Bearing) (LG-2500-303)	2
16A	5024105	Axle (5/8" Dia. x 24") (LG-1500-303)	1
16B	5024102	Axle (5/8" Dia. x 26-3/8") (LG-2500-303)	1
17A	5127219	Spacer (LG-1500-303)	2
17B	5127189	Spacer, 1-5/8" Long (LG-2500-303)	2
18A	5070066	Trailer Frame (Red), 5/8" Axle (LG-1500-303)	1
18B	5070060	Trailer Frame (Red), 5/8" Axle (LG-2500-303)	1
19	5034531	5/16"-18 x 5/8" Flange Lock Screw	3
20	5117323	H.H.C.S. 5/16"-18nc x 3/4" Long	6
21	5277981	High Flo Gold Series 2.1 g.p.m. Pump (60 psi, 8 Amp)	1
22	5117167	#10-24 x 5/8" Phillips Truss Head Machine Screw	3
23	5117168	#10-24 x 1" Truss Head Machine Screw	1
24	5167097	2" Dry 100# Back Mount Gauge	1
25	5302793	Quick Connect Manifold Assembly	1
26	5143430	Flat Washer	1
27	5143429	QC Manifold - QC Quarter Turn Cap	1
28A	5100804	Rigid By-Pass Tube Assembly (LG1500-303)	1
28B	5100804	Rigid By-Pass Tube Assembly (LG-2500-303)	1
29	5075018	Grommet - 1/2" I.D.	1
30	5095198	Boom Bracket (Light Duty)	2
31	5020133	Hose, 3/8"-1 Brd. x 30"	1
32	5277774	2-Nozzle Boom (QJ)	1
33	5274373	Drain Plug Cap, Tether, and Washer Assembly	1

PRO SERIES SPRAYERS
UTV SPRAYERS
SPOT SPRAYERS
ATV SPRAYERS
TRAILER SPRAYERS
UTILITY & 3PT SPRAYERS
SKID SPRAYERS & BOOMS
PUMPS
SPRAYER ACCESSORIES
DRY MATERIAL SPREADERS
TRAILER CARTS & AERATORS
SPRAYER COMPONENTS
PARTS LIST BREAKDOWNS

REPAIR PARTS: LG-20-TRL & LG-30-TRL

See Page 170 For Boom Parts List

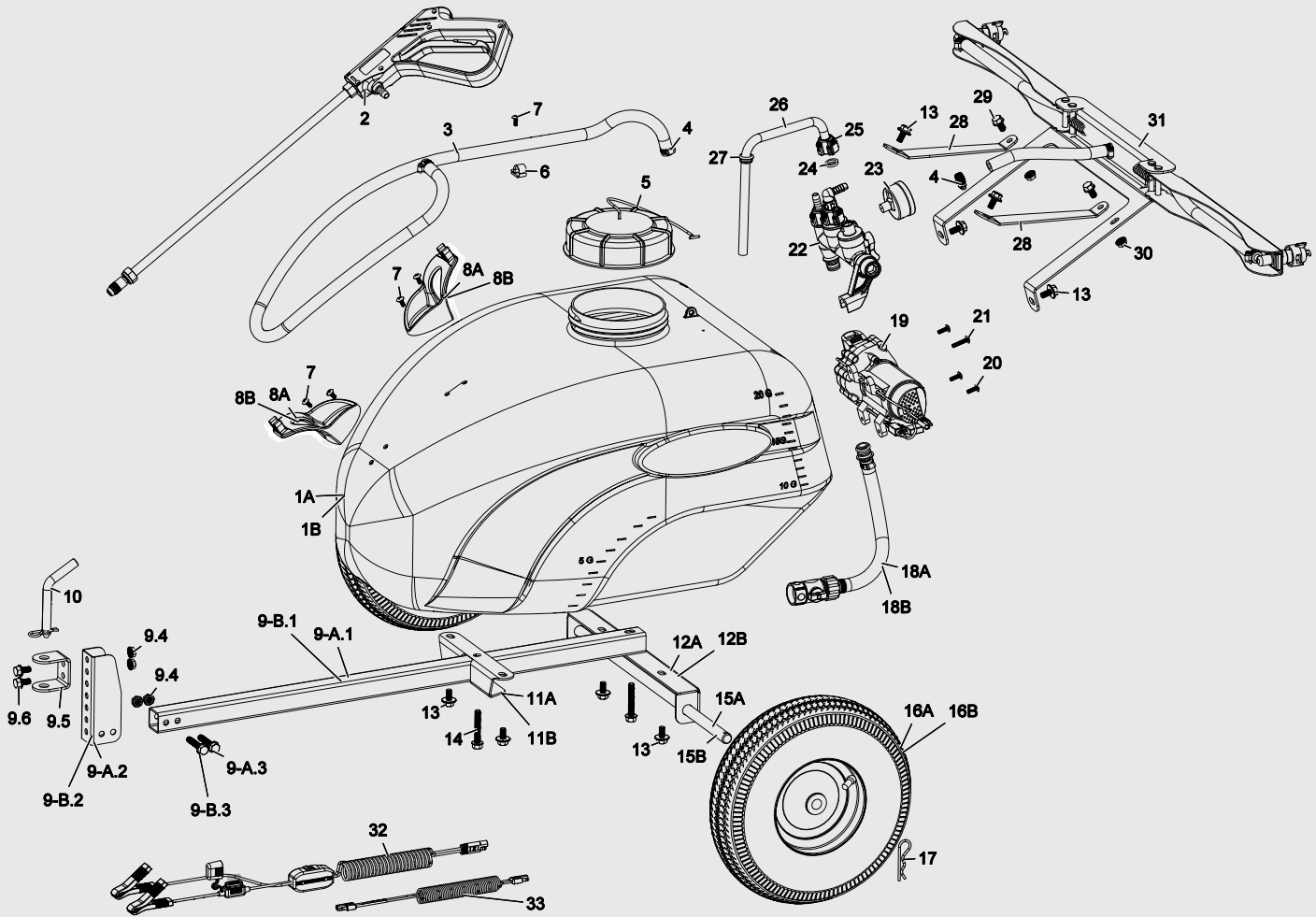

Ref. #	Part #	Description	Qty
1A	5169320	20 Gallon Trailer Tank (LG-20-TRL)	1
1B	5169321	30 Gallon Trailer Tank (LG-30-TRL)	1
2	5273959	Deluxe Pistol-Grip Handgun w/X-26 Tip	1
3	5020524	Hose, 3/8"-1 Bnd. x 15 Ft.	1
4	5051144	Hose Clamp, 3/8"	3
5	5058188	Tank Lid w/Lanyard	1
6	5051122	5/8" Black Nylon Loom Cable Clamp	1
7	5117234	#10-24 x 1/2" Phillips Truss Head Machine Screw	5
8A	5133275	20 Gallon Hose Wrap (LG-20-TRL)	2
8B	5133276	30 Gallon Hose Wrap (LG-30-TRL)	2
9-A	5278145	Tongue Assembly (LG-20-TRL)	1
9-A.1	5096113	Trailer Tongue (LG-20-TRL)	1
9-A.2	5038853	Hitch Bracket (LG-20-TRL)	1
9-A.3	5034639	H.H.C.S. Flanged 5/16"-18nc x 1 3/4" Long (LG-20-TRL)	2
9-B	5278141	Tongue Assembly (LG-30-TRL)	1
9-B.1	5096112	Trailer Tongue (LG-30-TRL)	1
9-B.2	5038870	Hitch Bracket (LG-30-TRL)	1
9-B.3	5034641	H.H.C.S. Flanged 5/16"-18nc x 1 3/4" Long (LG-30-TRL)	2
9.4	5006307	5/16-18nc Hex Flanged Whiz Nut Gr. 5	4
9.5	5038854	Hitch	1
9.6	5034634	H.H.C.S. Flanged 5/16"-18nc x 5/8" Long	2
10	5101202	Bent Clevis Pin (1/2" Dia.) w/Clip	1
11A	5095374	20 Gallon Tank Support (LG-20-TRL)	1
11B	5095373	30 Gallon Tank Support (LG-30-TRL)	1
12A	5095372	Axle Mount (LG-20-TRL)	1
12B	5095371	Axle Mount (LG-30-TRL)	1

Ref. #	Part #	Description	Qty
13	5034531	5/16"-18 x 5/8" Flange Lock Screw	8
14	5034640	H.H.C.S. Flanged 5/16"-18nc x 2" Long	2
15A	5024132	5/8" x 19-7/8" Axle (LG-20-TRL)	1
15B	5024133	3/4" x 21-13/16" Axle (LG-30-TRL)	1
16A	5021102	4.10/3.50-6 Wheel w/2 1/4" Offset & 5/8" BB (LG-20-TRL)	2
16B	5021090	4.80/400-8 Wheel w/2 1/4" Offset & 3/4" BB (LG-30-TRL)	2
17	5101065	#211 Hitch Pin Clip (Zinc Plated)	2
18A	5278280	Intake Assembly (LG-20-TRL)	1
18B	5278143	Intake Assembly (LG-30-TRL)	1
19	5277981	High Flo Gold Series 2.1 GPM Pump	1
20	5117167	#10-24 x 5/8" Phillips Truss Head Machine Screw	3
21	5117168	#10-24 x 1" Phillips Truss Head Machine Screw	1
22	5302352	Quick Connect Manifold Assembly	1
23	5167097	2" Dry 100# Back Mount Gauge	1
24	5143430	Flat Washer - Hose Barb Seal	1
25	5143429	Quarter Turn Cap	1
26	5149152	Rigid By-Pass Tube	1
27	5075018	Grommet, 1/2" I.D.	1
28	5037868	Boom Top Strap	2
29	5034634	H.H.C.S. Flanged 5/16"-18nc x 5/8" Long	2
30	5006307	5/16-18nc Hex Flanged Whiz Nut Gr. 5	2
31	5281003	2-Nozzle Boom (LG-TRL)	1
32	5278114	Lead Wire Assembly w/15A Fuse (96" Long)	1
33	5273212	5 Ft. Extension Cable	1

PRO SERIES SPRAYERS
UTV SPRAYERS
SPOT SPRAYERS
ATV SPRAYERS
TRAILER SPRAYERS
UTILITY & 3PT SPRAYERS
SKID SPRAYERS & BOOMS
PUMPS
SPRAYER ACCESSORIES
DRY MATERIAL SPREADERS
TRAILER CARTS & AERATORS
SPRAYER COMPONENTS
PARTS LIST BREAKDOWNS

REPAIR PARTS: TR-40-EX

See Page 172 For Boom Parts List

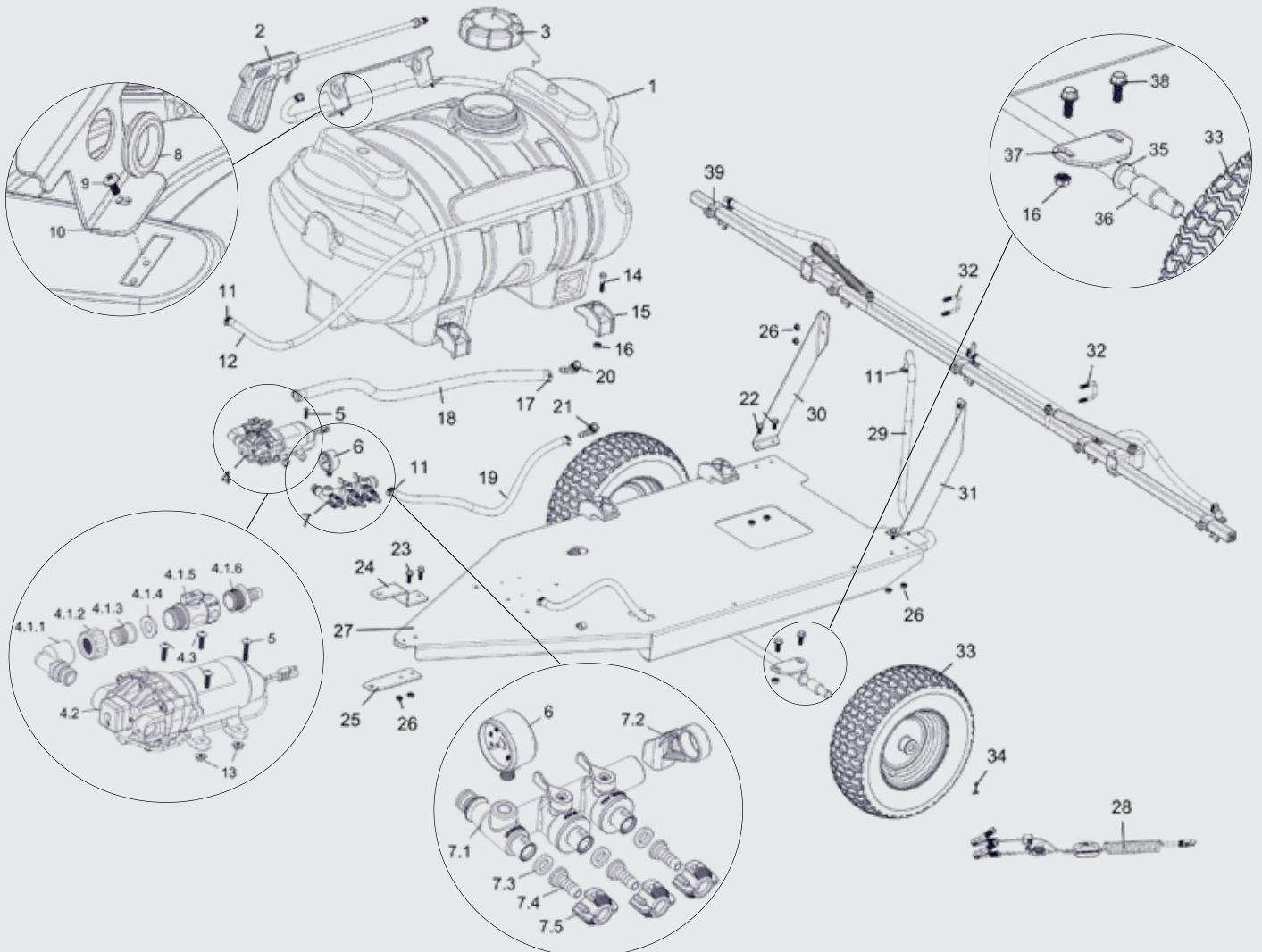

Ref. #	Part #	Description	Qty
1	5169245	40 Gallon Elliptical Tank (White)	1
1.1	5275014	1/2" Bulkhead Fitting Assembly	2
2	5273959	Deluxe Pistol-Grip Handgun w/X-26 Tip	1
3	5058188	Tank Lid w/Lanyard	1
4	5278022	Pump/Filter Sub-Assembly	1
4.1	5275570	Filter/Valve Sub-Assembly	1
4.1.1	5010430	Port Kit Elbow, 1/2" FNPT	1
4.1.2	5006209	Poly Knurled Swivel Nut, 3/4" FGHT	1
4.1.3	5005241	Nylon Swivel Adapter Spud, 1/2" NPT	1
4.1.4	5116242	Strainer, 1" Filter Washer	1
4.1.5	5143419	Swivel Shut-Off Valve, 3/4" GHT	1
4.1.6	5067121	Poly Hose Fitting, 3/4" MGHT 1/2" HB	1
4.2	5277981	High Flo Gold Series 2.1 GPM Pump	1
4.3	5117176	#10-24 x 3/4" Phillips Truss Head Machine Screw	3
5	5117168	#10-24 x 1" Phillips Truss Head Machine Screw	1
6	5167007	Pressure Gauge, 0-100 p.s.i.	1
7	5302791	Quick Connect Manifold Assembly	1
7.1	5302347	Quick Connect Manifold	1
7.2	5143422	QC Manifold - Support Bracket	1
7.3	5143430	Flat Washer - Hose Barb Seal	3
7.4	5143431	QC Manifold - 3/8" Hose Barb - Straight	3
7.5	5143429	QC Manifold - QC Quarter Turn Cap	3
8	5075014	Rubber Grommet (Black)	2
9	5117234	#10-24 x 1/2" Phillips Truss Head Machine Screw	3
10	5038775	Handgun Bracket	1
11	5051144	Hose Clamp, 3/8"	6
12	5020527	Hose, 3/8"-1 Brd. x 25 Ft.	1
13	5006186	#10-24 Hex Whiz (Flange) Locknut	5

Ref. #	Part #	Description	Qty
14	5034101	H.H.C.S., 3/8"-16 x 1 3/4"	4
15	5038698	Plastic Tank Hold-Down Leg Clip	4
16	5006259	3/8-16nc Hex Flanged Whiz Nut Gr. 5	8
17	5051114	Hose Clamp, 1/2"	2
18	5020028	Hose 1/2"-1 Brd. x 33"	1
19	5020529	Hose, 3/8"-1 Brd. x 34"	1
20	5010203	Poly Elbow, 1/2" MNPT x 1/2" HB	1
21	5010202	Poly Elbow, 1/2" MNPT x 3/8" HB	1
22	5117323	H.H.C.S. Flanged 5/16"-18nc x 3/4" Long	4
23	5117300	H.H.C.S. Flanged 5/16"-18nc x 1" Long	2
24	5038517	Hitch Bracket (Formed)	1
25	5038518	Hitch Bracket (Flat)	1
26	5006307	5/16-18nc Hex Flanged Whiz Nut Gr. 5	10
27	5278035	TR-40 Frame Weldment (Red)	1
28	5278114	Lead Wire Assembly w/15A Fuse & 30A Clips (96" Long)	1
29	5020127	Hose, 3/8"-1 Brd. x 72"	1
30	5038833	Boom Mount R.H.	1
31	5038834	Boom Mount L.H.	1
32	5034159	Square U-Bolt, 5/16" x 1 5/16" x 1 7/8"	2
33	5021089	Wheel, 16 x 6.50-8, Turf Tread	2
33.1	5031141	3/4" Bearing	2
34	5101207	Cotter Pin, 5/32" x 1-3/4"	2
35	5041094	Machinery Bushing, 3/4" ID x 1-1/4" OD	2
36	5127213	3/4" Dia. Axle Spacer x 1 1/2" Long	2
37	5274972	Axle Weldment (40 Gallon)	1
38	5117307	H.H.C.S. Flanged 3/8"-16nc x 1" Long	4
39	5301966	5-Nozzle Boom Assembly	1

PRO SERIES SPRAYERS
UTV SPRAYERS
SPOT SPRAYERS
ATV SPRAYERS
TRAILER SPRAYERS
UTILITY & 3PT SPRAYERS
SKID SPRAYERS & BOOMS
PUMPS
SPRAYER ACCESSORIES
DRY MATERIAL SPREADERS
TRAILER CARTS & AERATORS
SPRAYER COMPONENTS
PARTS LIST BREAKDOWNS

REPAIR PARTS: ATVTS-60-12V

See Page 172 For Boom Parts List

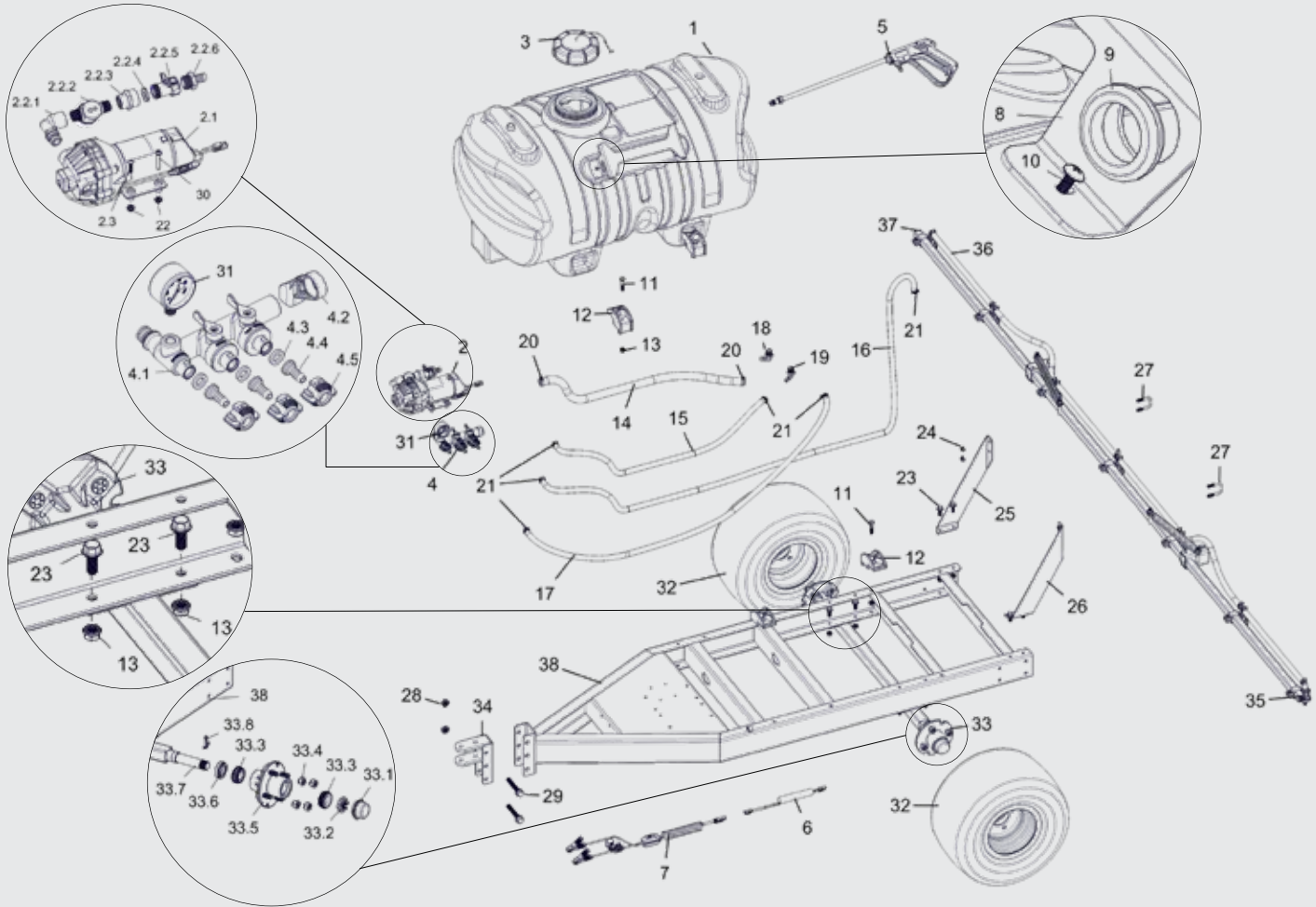

Ref. #	Part #	Description	Qty
1	5169249	60 Gallon Elliptical Tank (White)	1
1.1	5275014	1/2" Bulkhead Fitting Assembly	2
2	5278066	Pump/Strainer Assembly	1
2.1	5277982	Hi Flo Gold Series 3.8GPM Pump	1
2.2	5277174	Strainer/Valve Assembly	1
2.2.1	5010430	Port Kit Elbow, 1/2" FNPT	1
2.2.2	5116417	Nylon 'TEE' Line Strainer (1/2" MNPT, 50 Mesh)	1
2.2.3	5005190	Poly Adapter Coupler, 3/4" FGHT x 1/2" FNPT	1
2.2.4	5016066	Garden Hose Washer	1
2.2.5	5143419	Nylon Shut-Off Valve (3/4" GHT)	1
2.2.6	5067121	Poly Hose Fitting, 3/4" MGHT 1/2" HB	1
2.3	5117168	#10-24 x 1" Phillips Truss Head Machine Screw	3
3	5058188	Tank Lid w/Lanyard	1
4	5302791	Quick Connect Manifold Assembly	1
4.1	5302347	Quick Connect Manifold	1
4.2	5143422	QC Manifold - Support Bracket	1
4.3	5143430	Flat Washer - Hose Barb Seal	3
4.4	5143431	QC Manifold - 3/8" Hose Barb - Straight	3
4.5	5143429	QC Manifold - QC Quarter Turn Cap	3
5	5273959	Deluxe Pistol-Grip Handgun w/X-26 Tip	1
6	5273212	5 Ft Extension Cable	1
7	5278114	Lead Wire Assembly w/15A Fuse & 30A Clips (96" Long)	1
8	5038775	Handgun Bracket	1
9	5075014	Rubber Grommet (Black)	2
10	5117234	#10-24 x 1/2" Phillips Truss Head Machine Screw	3
11	5034101	H.H.C.S., 3/8"-16 x 1 3/4"	4
12	5038698	Plastic Tank Hold-Down Leg Clip	4
13	5006259	3/8-16nc Hex Flanged Whiz Nut Gr. 5	12
14	5020228	Hose, 1/2"-1 Brd. x 36"	1
15	5020538	Hose, 3/8"-1 Brd. x 43"	1
16	5020131	Hose, 3/8"-1 Brd. x 90"	1

Ref. #	Part #	Description	Qty
17	5020527	Hose, 3/8"-1 Brd. x 25 Ft.	1
18	5010203	Poly Elbow, 1/2" MNPT x 1/2" HB	1
19	5010202	Poly Elbow, 1/2" MNPT x 3/8" HB	1
20	5051114	Hose Clamp 1/2"	2
21	5051144	Hose Clamp, 3/8"	6
22	5006186	#10-24 Hex Whiz (Flange) Locknut	5
23	5117307	H.H.C.S. Flanged 3/8"-16nc x 1" Long	8
24	5006307	5/16-18nc Hex Flanged Whiz Nut Gr. 5	4
25	5038833	Boom Mount R.H.	1
26	5038834	Boom Mount L.H.	1
27	5034159	Square U-Bolt, 5/16" x 1 5/16" x 1 7/8"	2
28	5006337	1/2-13nc Hex Flanged Whiz Nut Gr. 5	2
29	5034700	H.H.C.S. Flanged 1/2"-13nc x 3 1/2" Long	2
30	5117338	#10-24 x 1 1/2 Long Truss Head Machine Screw	1
31	5167007	Pressure Gauge, 0-100 p.s.i.	1
32	5272464	Wheel, 18 x 9.5 x 8 - 4-Bolt	2
33	5274955	Axle & Hub Assembly	1
33.1	5046327	Grease Cap	2
33.2	5006300	Castle Nut, 1"	2
33.3	5031139	Cone Bearing	4
33.4	5006301	1/2"-20 Hex Cone Wheel Nut	8
33.5	5085018	Hub Assembly (4-Stud)	2
33.6	5072471	Grease Seal	2
33.7	5274954	Axle Weldment (ATVTS-60)	1
33.8	5101081	Cotter Pin, 5/32" x 2-1/4"	2
34	5273204	Hitch Clevis Weldment	1
35	5277923	Boom Clamp Assembly (1 In. Sq.)	7
36	5277696	7-Nozzle Harness (3/8")	1
37	5277780	7-Nozzle Boom Assembly	1
38	5278077	Frame Weldment (ATVTS-60) (Red)	1

PRO SERIES SPRAYERS
UTV SPRAYERS
SPOT SPRAYERS
ATV SPRAYERS
TRAILER SPRAYERS
UTILITY & 3PT SPRAYERS
SKID SPRAYERS & BOOMS
PUMPS
SPRAYER ACCESSORIES
DRY MATERIAL SPREADERS
TRAILER CARTS & AERATORS
SPRAYER COMPONENTS
PARTS LIST BREAKDOWNS

REPAIR PARTS: LG-40-3PT-12V

See Page 171 For Boom Parts List

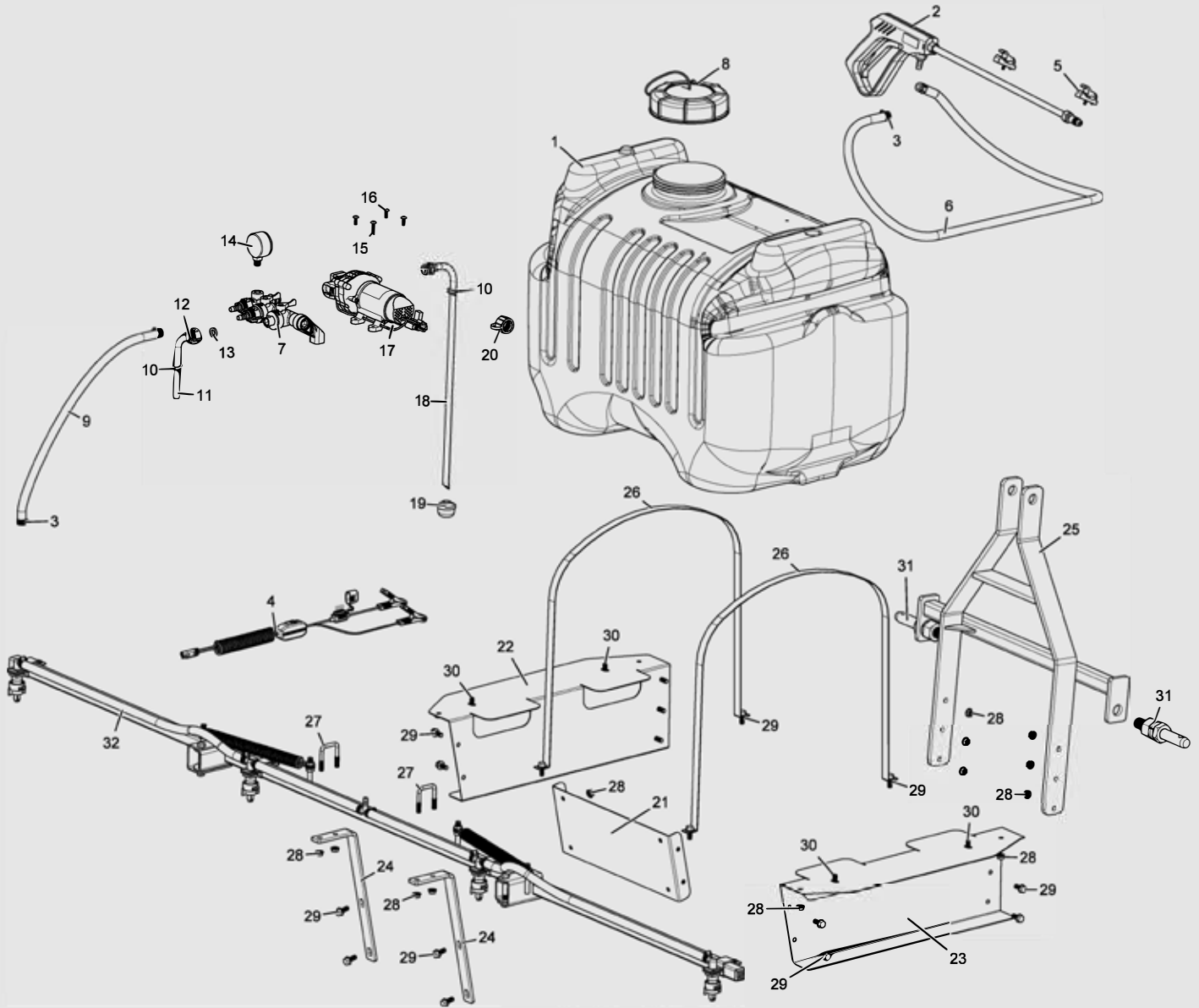

Ref. #	Part #	Description	Qty
1	5169296	40G. White Tank	1
2	5273959	Deluxe Pistol-Grip Handgun w/X-26 Tip	1
3	5051144	Hose Clamp, 3/8"	4
4	5278114	Lead Wire Assembly w/15A Fuse & 30A Clips (96" Long)	1
5	5278348	Deluxe Wand Clips & Screws (Pkg/2) (#10-24 Thread)	1
6	5020527	Hose, 3/8"-1 Brd. x 25 Ft.	1
7	5302793	Quick Connect Manifold Assembly	1
8	5058188	Tank Lid w/Lanyard	1
9	5020534	Hose, 3/8"-1 Brd. x 21"	1
10	5075018	Grommet, 1/2" I.D.	2
11	5100809	Rigid By-Pass Tube Assembly	1
12	5143429	Quick Connect Quarter Turn Cap	1
13	5143430	Flat Washer - Hose Barb Seal	1
14	5167007	Pressure Gauge, 0-100 p.s.i.	1
15	5117168	#10-24 x 1" Phillips Truss Head Machine Screw	1
16	5117167	#10-24 x 5/8" Phillips Truss Head Machine Screw	3
17	5277981	High Flo Gold Series 2.1 GPM Pump	1

Ref. #	Part #	Description	Qty
18	5100785	Intake Tube 90 Deg.w/Port & O-ring 21 1/2" Long	1
19	5116251	Strainer, Suction Line	1
20	5274373	Drain Plug Cap, Tether, and Washer Assembly	1
21	5027276	Back Tie Plate	1
22	5027277	Bolt Together 3PT Left Side	1
23	5027278	Bolt Together 3PT Right Side	1
24	5028314	Boom Support Bar	2
25	5277639	Front Frame Weldment	1
26	5133271	40 Gallon Tank Strap	2
27	5034159	Square U-Bolt, 5/16" x 1 5/16" x 1 7/8"	2
28	5006307	5/16-18nc Hex Flanged Whiz Nut Gr. 5	22
29	5117323	H.H.C.S. Flanged 5/16"-18nc x 3/4" Long	14
30	5034531	5/16"-18 x 5/8" Flange Lock Screw	4
31	5101294	Lift Arm Pin - Cat 1	2
32	5302290	4-Nozzle Boom Assembly	1

PRO SERIES SPRAYERS
UTV SPRAYERS
SPOT SPRAYERS
ATV SPRAYERS
TRAILER SPRAYERS
UTILITY & 3PT SPRAYERS
SKID SPRAYERS & BOOMS
PUMPS
SPRAYER ACCESSORIES
DRY MATERIAL SPREADERS
TRAILER CARTS & AERATORS
SPRAYER COMPONENTS
PARTS LIST BREAKDOWNS

REPAIR PARTS: LG-60-3PT

See Page 172 For Boom Parts List

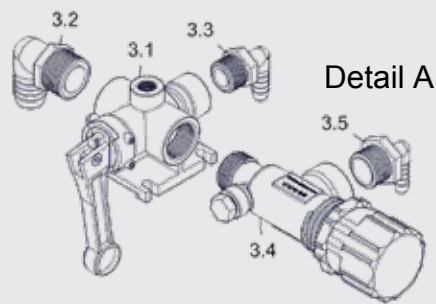
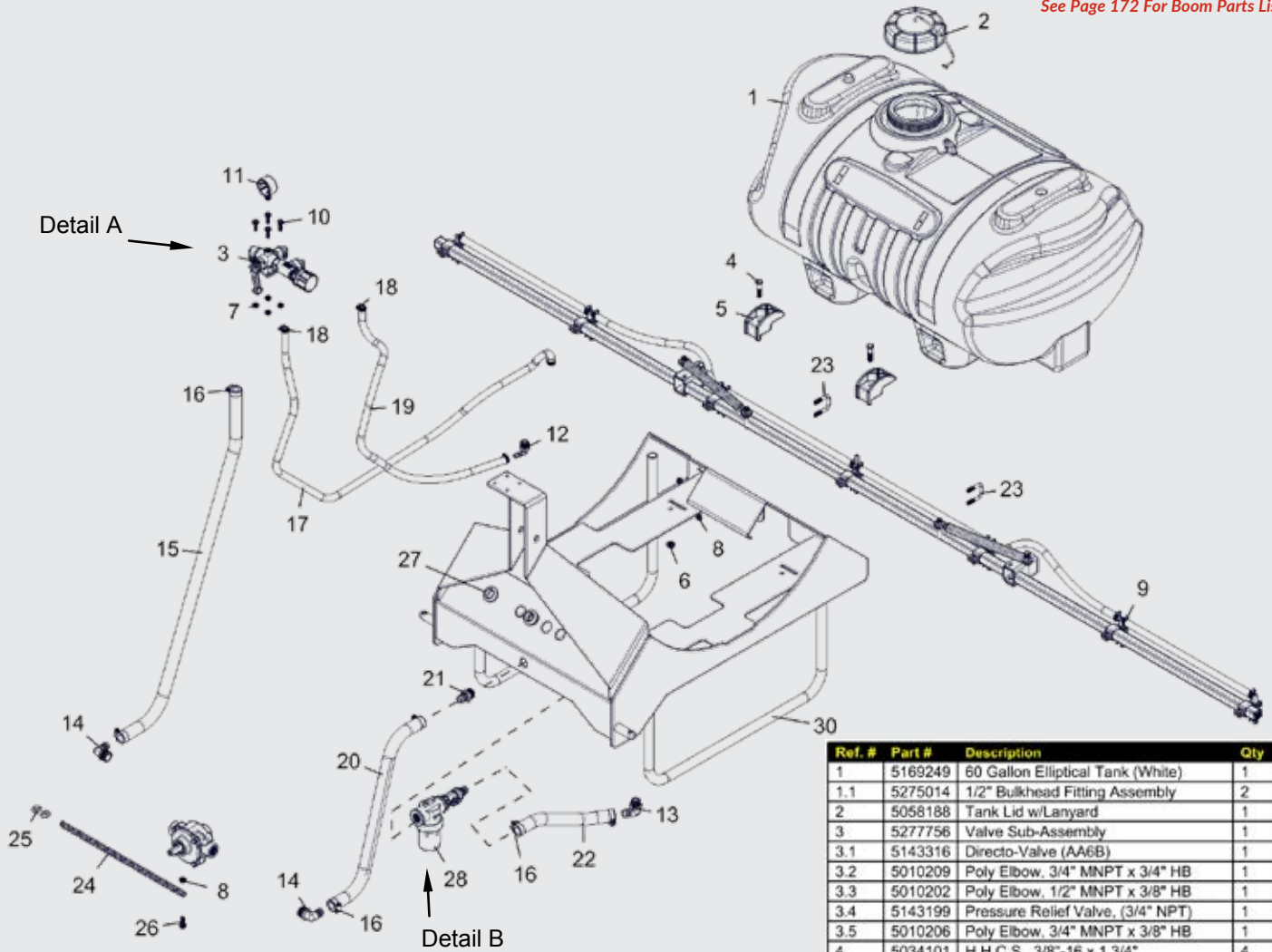

Detail A

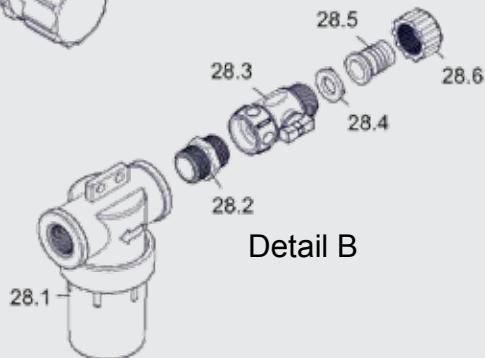

Detail B

Ref. #	Part #	Description	Qty
1	5169249	60 Gallon Elliptical Tank (White)	1
1.1	5275014	1/2" Bulkhead Fitting Assembly	2
2	5058188	Tank Lid w/Lanyard	1
3	5277756	Valve Sub-Assembly	1
3.1	5143316	Directo-Valve (AA6B)	1
3.2	5010209	Poly Elbow, 3/4" MNPT x 3/4" HB	1
3.3	5010202	Poly Elbow, 1/2" MNPT x 3/8" HB	1
3.4	5143199	Pressure Relief Valve, (3/4" NPT)	1
3.5	5010206	Poly Elbow, 3/4" MNPT x 3/8" HB	1
4	5034101	H.H.C.S., 3/8"-16 x 1 3/4"	4
5	5038698	Plastic Tank Hold-Down Leg Clip	4
6	5006259	3/8"-16 Hex Whiz (Flange) Locknut	4
7	5006306	1/4"-20 Hex Whiz (Flange) Locknut	4
8	5006307	5/16"-18 Hex Whiz (Flange) Locknut	5
9	5301197	7-Nozzle Boom Assembly (BK-70A)	1
10	5117301	1/4"-20 x 1" Hex Flange Screw	4
11	5167005	Gauge, 0-400 p.s.i. (Dry)	1
12	5010202	Poly Elbow, 1/2" MNPT x 3/8" HB	1
13	5010205	Poly Elbow, 1/2" MNPT x 3/4" HB	1
14	5010209	Poly Elbow, 3/4" MNPT x 3/4" HB	2
15	5020227	Hose, 3/4"-1 Brd. x 48"	1
16	5051024	Hose Clamp, 3/4"	6
17	5020519	Hose, 3/8"-1 Brd. x 64"	1
18	5051144	Hose Clamp, 3/8"	4
19	5020514	Hose, 3/8"-1 Brd. x 43"	1
20	5020105	Hose, 3/4"-2 Brd. x 36"	1
21	5067127	Poly Fitting, 3/4" MNPT x 3/4" HB	1
22	5020290	Hose, 3/4"-2 Brd. x 16"	1
23	5034159	Square U-Bolt, 5/16" x 1 5/16" x 1 7/8"	2
24	5049017	Torque Chain, 24"	1
25	5082006	"S" Hook	1
26	5117300	5/16"-18 x 1" Flange Whiz Lock Screw	1
27	5075015	Rubber Grommet	2
28	5274745	Strainer Sub-Assembly	1
28.1	5116322	3/4" Black Poly Strainer	1
28.2	5005196	Poly Adapter, 3/4" MNPT x 3/4" MGHT	1
28.3	5143419	Swivel Shut-Off Valve	1
28.4	5016066	Garden Hose Washer	1
28.5	5149037	Poly Swivel, 3/4" Flat Seat Hose Barb	1
28.6	5006209	Poly Knurled Swivel Nut, 3/4" FGHT	1
30	5275762	60 Gallon 3-Point Carrier (RED)	1

PRO SERIES SPRAYERS
UTV SPRAYERS
SPOT SPRAYERS
ATV SPRAYERS
TRAILER SPRAYERS
UTILITY & 3PT SPRAYERS
SKID SPRAYERS & BOOMS
PUMPS
SPRAYER ACCESSORIES
SPRAYER MATERIAL SPREADERS
TRAILER CARTS & AERATORS
SPRAYER COMPONENTS
PARTS LIST BREAKDOWNS

REPAIR PARTS: UTV BOOMLESS SPRAYERS

See Pages 171 & 172 For Boom Parts List

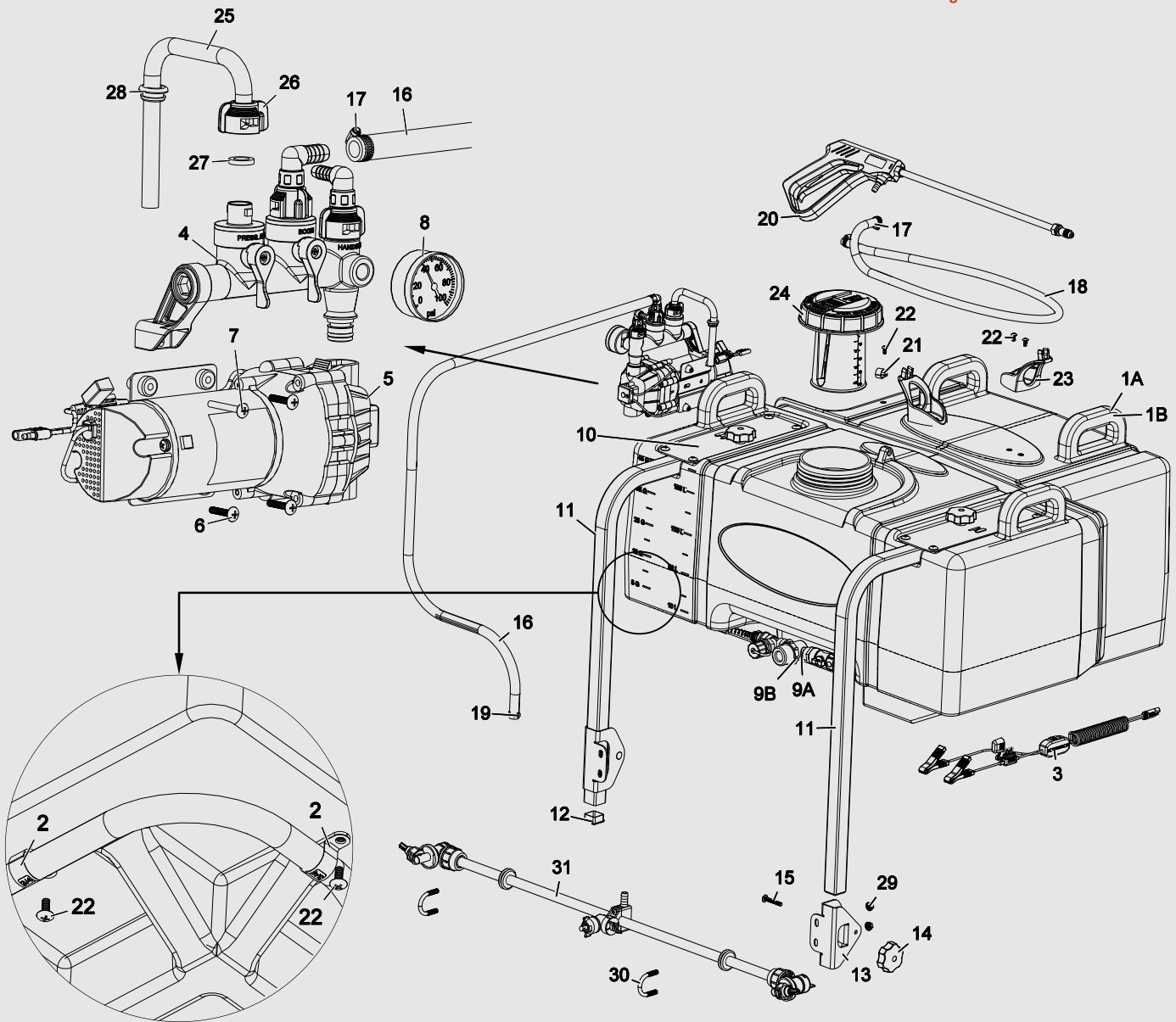

Ref. #	Part #	Description	Qty
1A	5169329	45 Gallon UTV Tank (UTV-45-BL)	1
1B	5169325	65 Gallon UTV Tank (UTV-65-BL)	1
2	5051152	3/4" Black Nylon Loom Clamp	2
3	5278114	Lead Wire Assembly w/15A Fuse (96" Long)	1
4	5278781	BL Quick Connect Manifold Assembly	1
5	5277982	Hi Flo Gold Series 3.8 GPM Pump	1
6	5117168	#10-24 x 1" Phillips Truss Head Machine Screw	3
7	5117338	#10-24 x 1 1/2 Long Truss Head Machine Screw	1
8	5167097	2" Dry 100# Back Mount Gauge	1
9A	5278928	45G UTV Intake Plumbing (UTV-45-BL)	1
9B	5278718	65G UTV Intake Plumbing (UTV-65-BL)	1
10	5278715	UTV Boom Mount	2
11	5095395	UTV Boom Mount	2
12	5046448	Square Cap, Black (1 1/4")	4
13	5051151	Boom Clamp	2
14	5088026	5 Lobe Knob 1/4-20UNC	2
15	5034807	1/4-20nc X 1.75" Carriage Bolt	2

Ref. #	Part #	Description	Qty
16	5020152	Hose, 1/2"-1 Brd. x 6 Ft. (72")	1
17	5051144	Hose Clamp, 3/8"	2
18	5020527	Hose, 3/8"-1 Brd. x 25 Ft.	1
19	5051114	Hose Clamp, 1/2"	2
20	5273959	Deluxe Pistol-Grip Handgun w/X-26 Tip	1
21	5051122	5/8" Black Nylon Loom Cable Clamp	1
22	5117234	#10-24 x 1/2" Phillips Truss Head Machine Screw	7
23	5133276	Hose Wrap	2
24	5058200	32 oz -1000 ml Multi-LID Complete Assembly	1
25	5149157	Rigid By-Pass Tube Assembly	1
26	5143429	Quick Connect Quarter Turn Cap	1
27	5143430	Flat Washer - Hose Barb Seal	1
28	5075018	Grommet, 1/2" I.D.	1
29	5006307	5/16-18nc Hex Flanged Whiz Nut Gr. 5	4
30	5034220	Round U-Bolt, 5/16"-18 x 1 5/16" x 1 3/4"	2
31	5275260	"Wet Boom" Assembly	1

PRO SERIES SPRAYERS
UTV SPRAYERS
SPOT SPRAYERS
ATV SPRAYERS
TRAILER SPRAYERS
UTILITY & 3PT SPRAYERS
SKID SPRAYERS & BOOMS
PUMPS
SPRAYER ACCESSORIES
DRY MATERIAL SPREADERS
TRAILER CARTS & AERATORS
SPRAYER COMPONENTS
PARTS LIST BREAKDOWNS

REPAIR PARTS: UTV-7-NOZZLE SPRAYERS

See Pages 171 & 172 For Boom Parts List

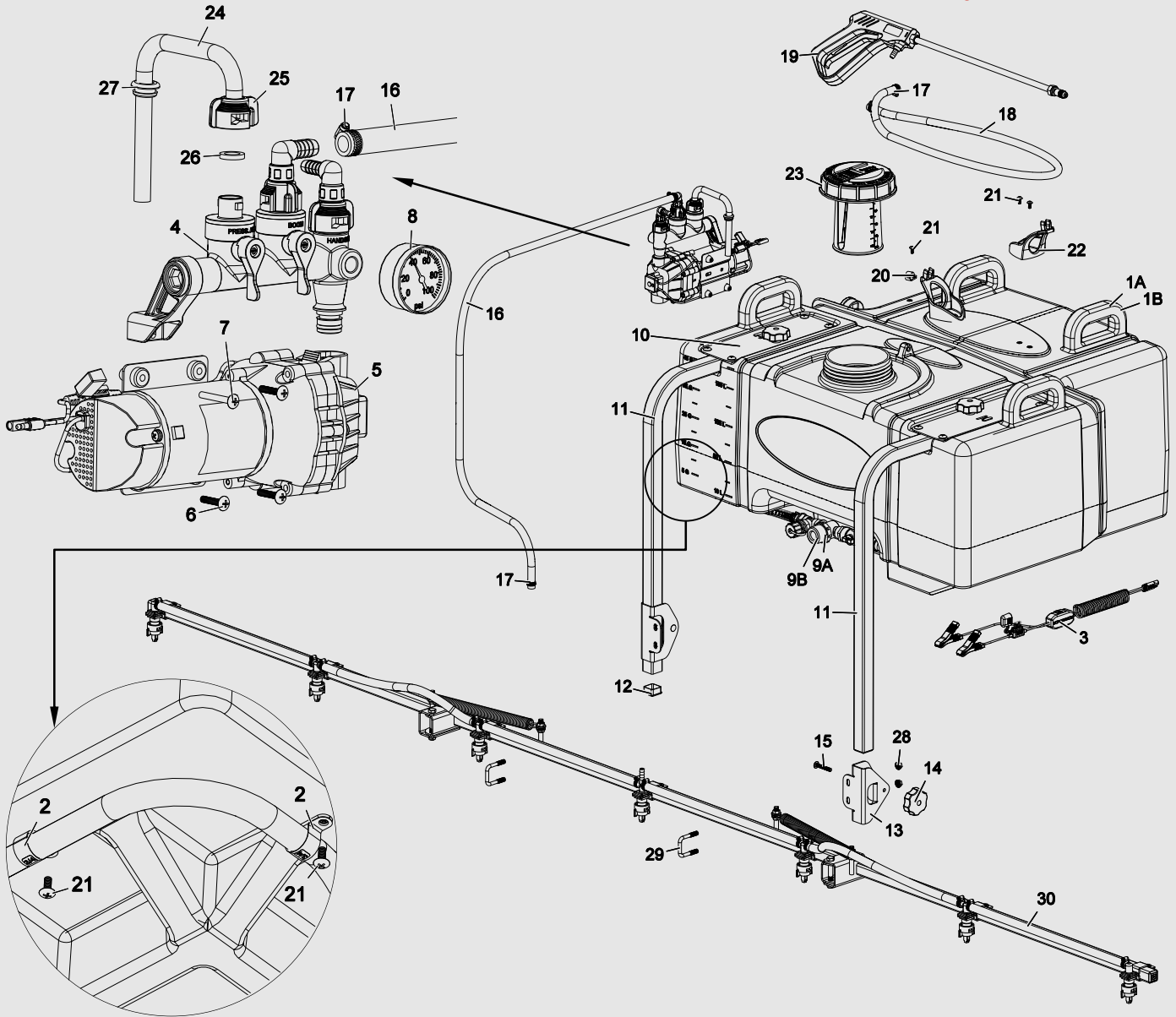

Ref. #	Part #	Description	Qty
1A	5169329	45 Gallon UTV Tank (UTV-45-7)	1
1B	5169325	65 Gallon UTV Tank (UTV-65-7)	1
2	5051152	3/4" Black Nylon Loom Clamp	2
3	5278114	Lead Wire Assembly w/15A Fuse (96" Long)	1
4	5278714	Quick Connect Manifold Assembly	1
5	5277982	Hi Flo Gold Series 3.8 GPM Pump	1
6	5117168	#10-24 x 1" Phillips Truss Head Machine Screw	3
7	5117338	#10-24 x 1 1/2 Long Truss Head Machine Screw	1
8	5167097	2" Dry 100# Back Mount Gauge	1
9A	5278928	45G UTV Intake Plumbing (UTV-45-7)	1
9B	5278718	65G UTV Intake Plumbing (UTV-65-7)	1
10	5278715	UTV Boom Mount	2
11	5095395	UTV Boom Mount	2
12	5046448	Square Cap, Black (1-1/4")	4
13	5051151	Boom Clamp	2
14	5088026	5 Lobe Knob 1/4-20UNC	2
15	5034807	1/4-20nc X 1.75" Carriage Bolt	2

Ref. #	Part #	Description	Qty
16	5020127	Hose, 3/8"-1 Brd. x 72"	1
17	5051144	Hose Clamp, 3/8"	4
18	5020527	Hose, 3/8"-1 Brd. x 25 Ft.	1
19	5273959	Deluxe Pistol-Grip Handgun w/X-26 Tip	1
20	5051122	5/8" Black Nylon Loom Cable Clamp	1
21	5117234	#10-24 x 1/2" Phillips Truss Head Machine Screw	7
22	5133276	Hose Wrap	2
23	5058200	32 oz -1000 ml Multi-LID Complete Assembly	1
24	5149157	Rigid By-Pass Tube Assembly	1
25	5143429	Quick Connect Quarter Turn Cap	1
26	5143430	Flat Washer - Hose Barb Seal	1
27	5075018	Grommet, 1/2" I.D.	1
28	5006307	5/16-18nc Hex Flanged Whiz Nut Gr. 5	4
29	5034159	Square U-Bolt, 5/16" x 1 5/16" x 1 7/8"	2
30	5301897	7-Nozzle Boom Assembly	1

PRO SERIES SPRAYERS
UTV SPRAYERS
SPOT SPRAYERS
ATV SPRAYERS
TRAILER SPRAYERS
UTILITY & 3PT SPRAYERS
SKID SPRAYERS & BOOMS
PUMPS
SPRAYER ACCESSORIES
DRY MATERIAL SPREADERS
TRAILER CARTS & AERATORS
SPRAYER COMPONENTS
PARTS LIST BREAKDOWNS

REPAIR PARTS: ATV BOOMS

PRO SERIES SPRAYERS
UTV SPRAYERS
SPOT SPRAYERS
ATV SPRAYERS
TRAILER SPRAYERS
UTILITY & 3PT SPRAYERS
SKID SPRAYERS & BOOMS
PUMPS
SPRAYER ACCESSORIES
DRY MATERIAL SPREADERS
TRAILER CARTS & AERATORS
SPRAYER COMPONENTS
PARTS LIST BREAKDOWNS

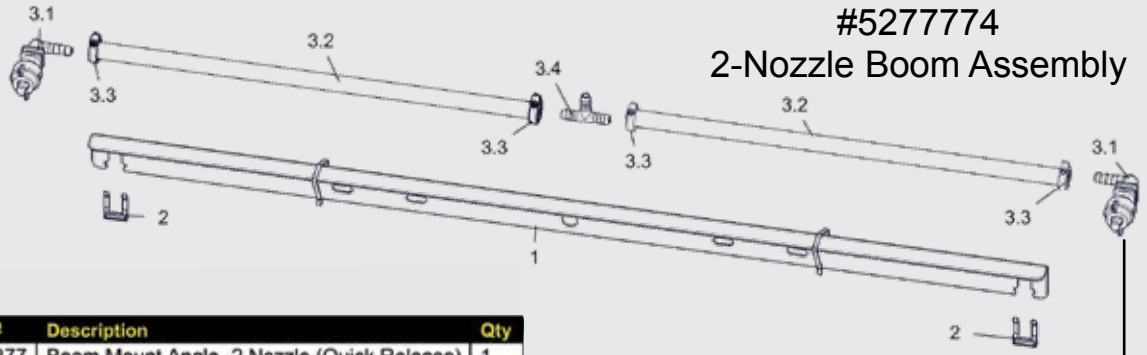

#5277774
2-Nozzle Boom Assembly

Ref. #	Part #	Description	Qty
1	5095377	Boom Mount Angle -2 Nozzle (Quick Release)	1
2	5053110	Plastic Retaining Clip (14 & 16 Ga.)	2
3	5277692	2-Nozzle Harness (3/8")	1
3.1	5281306	ELL Nozzle Sub-Assembly (3/8")	2
3.1.1	5056113	Single Hose Shank (3/8" Hose)	1
3.1.2	5143543	Check Valve Strainer, 50 Mesh, 5 PSI	1
3.1.3	5016157	Seat Washer (QJ Caps)	1
3.1.4	5018274	Turbo FloodJet Tip (TF-VP3)	1
3.1.5	5046251	QJ Cap Only (Black)	1
3.2	5020510	Hose, 3/8"-1 Brd. x 19-3/8"	2
3.3	5051144	Hose Clamp, 3/8"	4
3.4	5086025	Poly Hose Tee, 3/8" HB	1

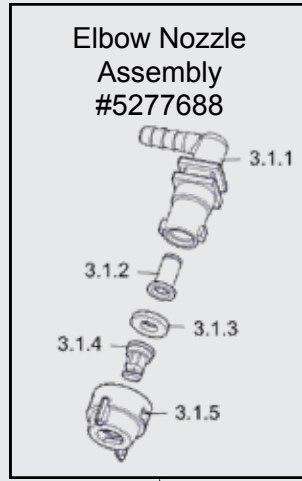

NOTE: 3.1.2 - All Booms Manufactured Prior To 10/01/17 Will Use #5116019

#5281003
2-Nozzle Boom Assembly

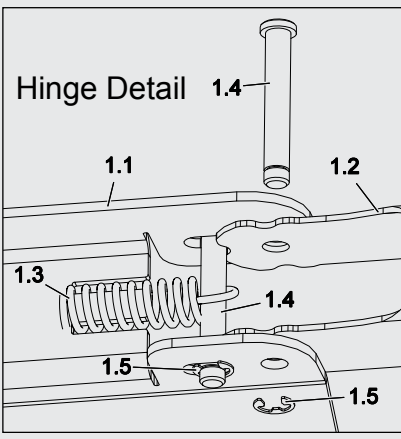
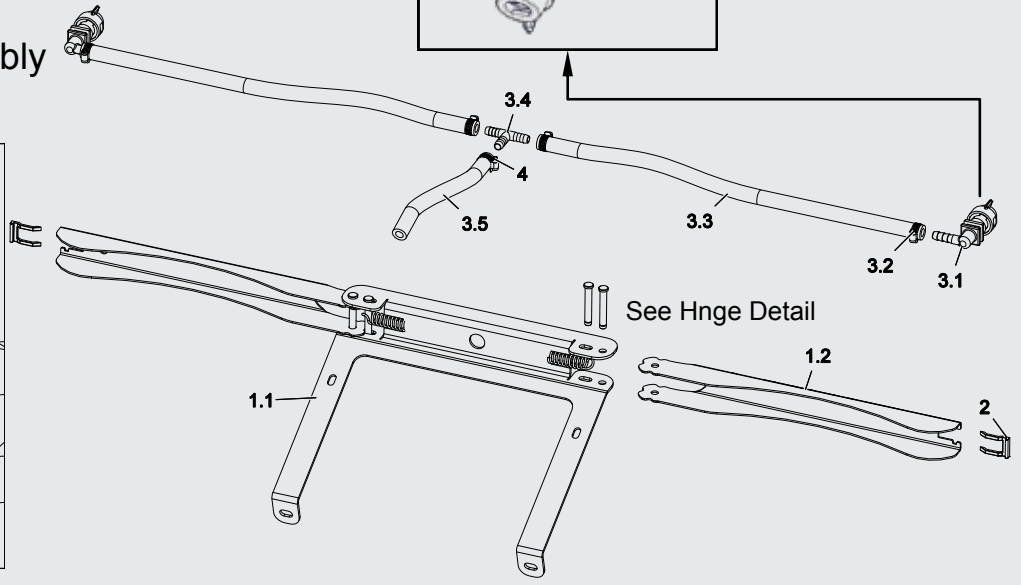

Ref. #	Part #	Description	Qty
1	5280993	2-Nozzle Boom Sub Assembly (LG-TRL)	1
1.1	5037922	Break Away Boom Lower Support	1
1.2	5030923	Break Away Boom	2
1.3	5019755	Boom Detent Spring	2
1.4	5101366	5/16 X 2 Grooved Clevis Pin	4
1.5	5053117	5/16 E CLIP	4
2	5053110	Plastic Retaining Clip (14 & 16 Ga.)	2
3	5281004	2-Nozzle Boom Harness Assembly (LG-TRL)	1
3.1	5281306	ELL Nozzle Sub-Assembly (3/8")	2
3.1.1	5056113	Single Hose Shank (3/8" Hose)	1

Ref. #	Part #	Description	Qty
3.1.2	5143543	Check Valve Strainer, 50 Mesh, 5 PSI	1
3.1.3	5016157	Seat Washer (QJ Caps)	1
3.1.4	5018274	Turbo FloodJet Tip (TF-VP3)	1
3.1.5	5046251	QJ Cap Only (Black)	1
3.2	5051144	Hose Clamp, 3/8"	4
3.3	5020534	Hose, 3/8"-1 Brd. x 21"	2
3.4	5086025	Poly Hose Tee, 3/8" HB	1
3.5	5020585	Hose, 3/8"-1 Brd. X 8"	1
4	5051144	Hose Clamp, 3/8"	1

REPAIR PARTS: ATV BOOMS

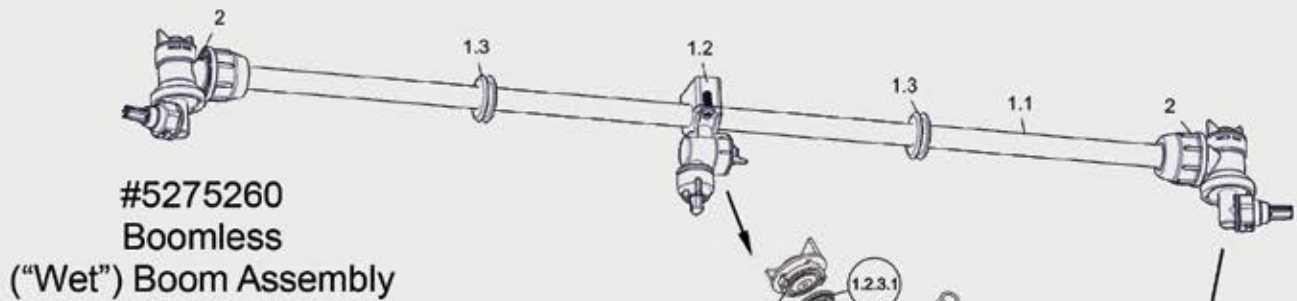

#5275260
Boomless
("Wet") Boom Assembly

Ref. #	Part #	Description	Qty
1	5275712	Wet Boom Sub-Assembly	1
1.1	5100316	Boom Tube	1
1.2	5275123	Center Nozzle Assembly (Wet Boom)	1
1.2.1	5274862	Center Boomless Nozzle Cap w/Gasket	1
1.2.2	5018329	Center Spray Tip	1
1.2.3	5088024	Valve (On/Off) Knob w/Diaphragm	1
1.2.3.1	5063255	Diaphragm	1
1.3	5075016	Rubber Grommet	2
2	5275122	End Nozzle Assembly (Wet Boom)	2
2.1	5274861	XT Spray Nozzle, Cap, & O-Ring	1
2.2	5088024	Valve (On/Off) Knob w/Diaphragm	1
2.2.1	5063255	Diaphragm	1

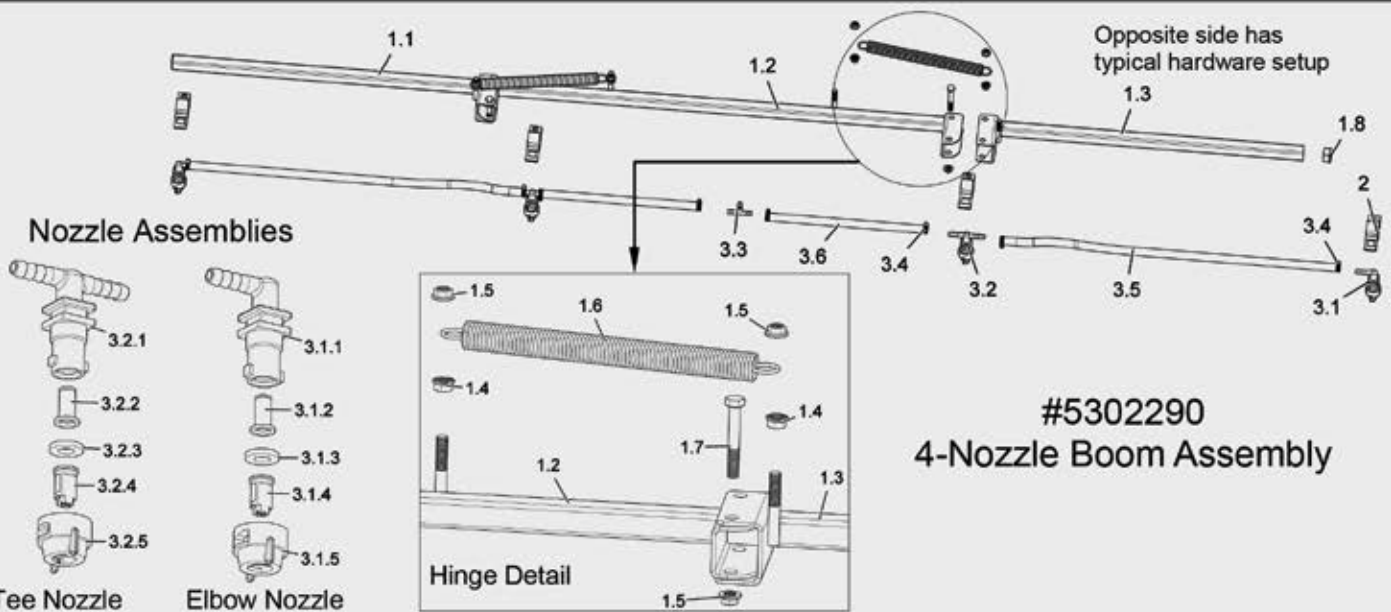

#5302290
4-Nozzle Boom Assembly

Ref. #	Part #	Description	Qty
1	5277778	4-Nozzle Boom Only	1
1.1	5277832	Outer Boom Weldment 1" Sq. Tube L.H.	1
1.2	5277831	Center Boom Weldment 1" Sq. Tube	1
1.3	5277833	Outer Boom Weldment 1" Sq. Tube R.H.	1
1.4	5006259	3/8-16nc Hex Flanged Whiz Nut Gr. 5	4
1.5	5006345	3/8"-16 Flange Locknut (Grade F)	6
1.6	5019228	Extension Spring	2
1.7	5034169	H.H.C.S., 3/8"-16 x 2 1/2"	2
1.8	5046106	Square Cap, Black (1" Square Tube)	2
2	5272164	Nozzle Clamp (1" Sq. Tube)	4
3	5277694	4-Nozzle Harness (3/8")	1
3.1	5281304	"ELL" Nozzle Sub-Assembly (3/8")	2
3.1.1	5056113	Single Hose Shank (3/8" Hose)	1
3.1.2	5143543	Check Valve Strainer, 50 Mesh, 5 PSI	1

Ref. #	Part #	Description	Qty
3.1.3	5016157	Seat Washer (QJ Caps)	1
3.1.4	5018371	Air-Induction XR Flat Spray Tip (AIXR11002VP)	1
3.1.5	5046219	Quick TeeJet Cap ONLY (Yellow)	1
3.2	5281307	"TEE" Nozzle Sub-Assembly (3/8")	2
3.2.1	5056114	Double Hose Shank (3/8" Hose)	1
3.2.2	5143543	Check Valve Strainer, 50 Mesh, 5 PSI	1
3.2.3	5016157	Seat Washer (QJ Caps)	1
3.2.4	5018371	Air-Induction XR Flat Spray Tip (AIXR11002VP)	1
3.2.5	5046219	Quick TeeJet Cap ONLY (Yellow)	1
3.3	5086025	Poly Hose Tee, 3/8" HB	1
3.4	5051144	Hose Clamp, 3/8"	8
3.5	5020523	Hose, 3/8"-1 Brd. x 31"	2
3.6	5020522	Hose, 3/8"-1 Brd. x 13-3/4"	2

PRO SERIES SPRAYERS
 ATV SPRAYERS
 SPOT SPRAYERS
 ATV SPRAYERS
 TRAILER SPRAYERS
 UTILITY & 3PT SPRAYERS
 SKID SPRAYERS & BOOMS
 PUMPS
 SPRAYER ACCESSORIES
 DRY MATERIAL SPREADERS
 TRAILER CARTS & AERATORS
 SPRAYER COMPONENTS
PARTS LIST BREAKDOWNS

REPAIR PARTS: ATV BOOMS

PRO SERIES SPRAYERS
UTV SPRAYERS
SPOT SPRAYERS
ATV SPRAYERS
TRAILER SPRAYERS
UTILITY & 3PT SPRAYERS
SKID SPRAYERS & BOOMS
PUMPS
SPRAYER ACCESSORIES
DRY MATERIAL SPREADERS
TRAILER CARTS & AERATORS
SPRAYER COMPONENTS
PARTS LIST BREAKDOWNS

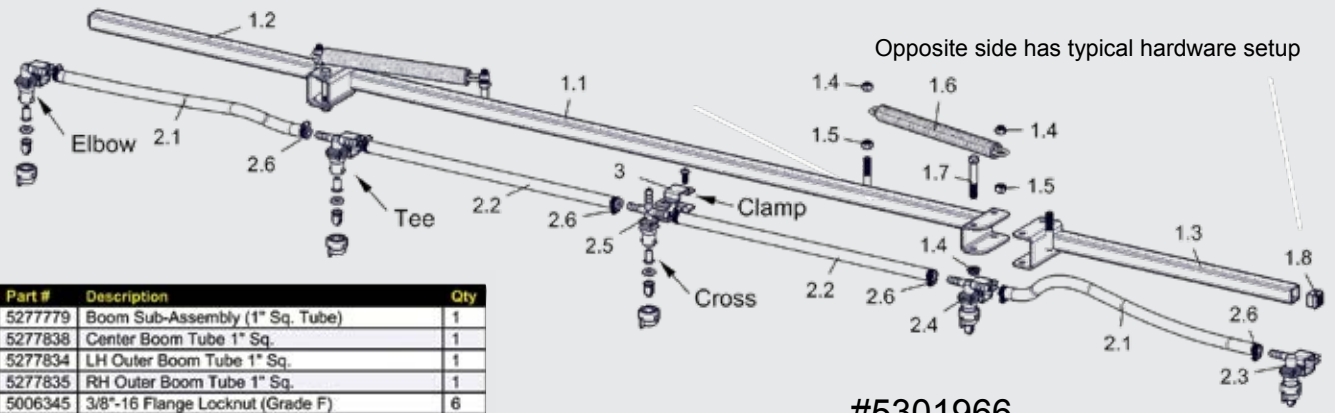

#5301966
5-Nozzle Boom Assembly

NOTE: 2.3.2; 2.4.2; 2.5.2 - All Booms Manufactured Prior To 10/01/17 Will Use #5116019

Ref. #	Part #	Description	Qty
1	5277779	Boom Sub-Assembly (1" Sq. Tube)	1
1.1	5277838	Center Boom Tube 1" Sq.	1
1.2	5277834	LH Outer Boom Tube 1" Sq.	1
1.3	5277835	RH Outer Boom Tube 1" Sq.	1
1.4	5006345	3/8"-16 Flange Locknut (Grade F)	6
1.5	5006259	3/8"-16 Hex Whiz (Flange) Locknut	4
1.6	5019228	Extension Spring	2
1.7	5034169	H.H.C.S., 3/8"-16 x 2 1/2"	2
1.8	5046106	Square Cap, Black (1" Square Tube)	2
2	5277695	5-Nozzle Harness (3/8" & 1" Sq Tube)	1
2.1	5020534	Hose, 3/8"-1 Brd. x 21"	2
2.2	5020531	Hose, 3/8"-1 Brd. x 19-3/8"	2
2.3	5281304	"ELL" Nozzle Sub-Assembly (3/8")	2
2.3.1	5056113	Single Hose Shank (3/8" Hose)	1
2.3.2	5143543	Check Valve Strainer, 50 Mesh, 5 PSI	1
2.3.3	5016157	Seat Washer (QJ Caps)	1
2.3.4	5018371	Air-Induction XR Flat Spray Tip (AIXR11002VP)	1
2.3.5	5046219	Quick TeeJet Cap ONLY (Yellow)	1
2.4	5281307	"TEE" Nozzle Sub-Assembly (3/8")	2
2.4.1	5056114	Double Hose Shank (3/8" Hose)	1
2.4.2	5143543	Check Valve Strainer, 50 Mesh, 5 PSI	1
2.4.3	5016157	Seat Washer (QJ Caps)	1
2.4.4	5018371	Air-Induction XR Flat Spray Tip (AIXR11002VP)	1
2.4.5	5046219	Quick TeeJet Cap ONLY (Yellow)	2
2.5	5281308	"Cross" Nozzle Sub-Assembly (3/8")	1
2.5.1	5056115	Triple Hose Shank (3/8" Hose)	1
2.5.2	5143543	Check Valve Strainer, 50 Mesh, 5 PSI	1
2.5.3	5016157	Seat Washer (QJ Caps)	1
2.5.4	5018371	Air-Induction XR Flat Spray Tip (AIXR11002VP)	1
2.5.5	5046219	Quick TeeJet Cap ONLY (Yellow)	1
2.6	5051144	Hose Clamps, 3/8"	8
3	5277923	Boom Clamp Assembly (1in Sq.)	5

5-Nozzle Boom & 7-Nozzle Boom Nozzle Assemblies

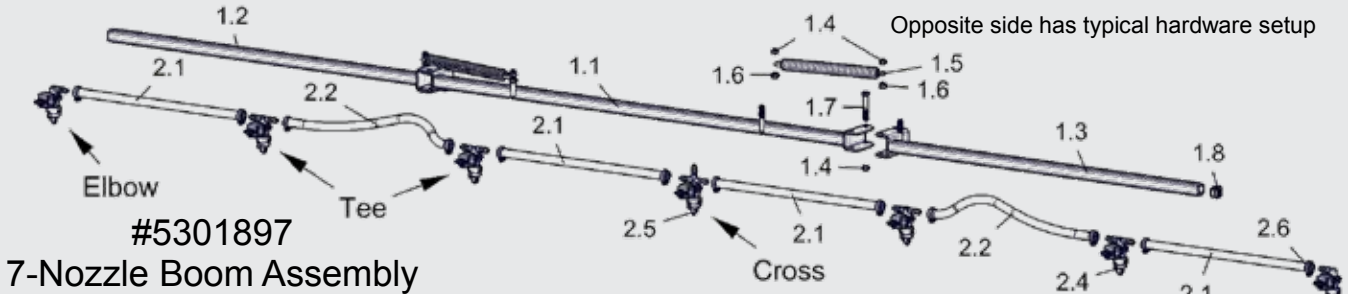
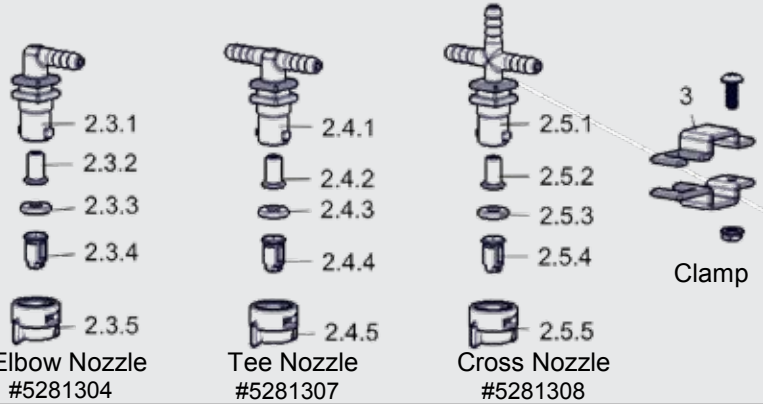

#5301897
7-Nozzle Boom Assembly

Ref. #	Part #	Description	Qty
1	5277780	7-Nozzle Boom Assembly	1
1.1	5100764	Center Boom Tube 1" Sq.	1
1.2	5100765	Outer Boom Tube 1" Sq.	1
1.3	5100765	Outer Boom Tube 1" Sq.	1
1.4	5006345	3/8"-16 Hex Locknut	6
1.5	5019228	Extension Spring	2
1.6	5006259	3/8"-16 Hex Nut	4
1.7	5034169	H.H.C.S., 3/8"-16 x 2 1/2"	2
1.8	5046106	Square Cap, Black (1" Square Tube)	2
2	5277696	7-Nozzle Harness (3/8")	1
2.1	5020531	Hose, 3/8"-1 Brd. x 19-3/8"	4
2.2	5020534	Hose, 3/8"-1 Brd. x 21"	2
2.3	5281304	"ELL" Nozzle Sub-Assembly (3/8")	2
2.3.1	5056113	Single Hose Shank (3/8" Hose)	1
2.3.2	5143543	Check Valve Strainer, 50 Mesh, 5 PSI	1
2.3.3	5016157	Seat Washer (QJ Caps)	1
2.3.4	5018371	Air-Induction XR Flat Spray Tip (AIXR11002VP)	1

Ref. #	Part #	Description	Qty
2.3.5	5046219	Quick TeeJet Cap ONLY (Yellow)	1
2.4	5281307	"TEE" Nozzle Sub-Assembly (3/8")	4
2.4.1	5056114	Double Hose Shank (3/8" Hose)	1
2.4.2	5143543	Check Valve Strainer, 50 Mesh, 5 PSI	1
2.4.3	5016157	Seat Washer (QJ Caps)	1
2.4.4	5018371	Air-Induction XR Flat Spray Tip (AIXR11002VP)	1
2.4.5	5046219	Quick TeeJet Cap ONLY (Yellow)	1
2.5	5281308	"Cross" Nozzle Sub-Assembly (3/8")	1
2.5.1	5056115	Triple Hose Shank (3/8" Hose)	1
2.5.2	5143543	Check Valve Strainer, 50 Mesh, 5 PSI	1
2.5.3	5016157	Seat Washer (QJ Caps)	1
2.5.4	5018371	Air-Induction XR Flat Spray Tip (AIXR11002VP)	1
2.5.5	5046219	Quick TeeJet Cap ONLY (Yellow)	1
2.6	5051144	Hose Clamp - 3/8"	12
3	5277923	Vari-Quick Clamp (1" Sq. Tube)	7

SPRAYING INFORMATION

THE PERFORMANCE OF ANY AGRICULTURAL CHEMICAL DEPENDS UPON THE PROPER APPLICATION OF THE CORRECT AMOUNT BASED ON THE CHEMICAL MANUFACTURERS RECOMMENDATION. BE SURE THAT YOUR EQUIPMENT HAS BEEN PROPERLY CALIBRATED BEFORE SPRAYING.

IN THE FIELD

Having established the proper spray tip style and size, spraying pressure and nozzle spacing the tractor throttle setting to provide the required rig speed should be determined. Because of wheel slippage, the actual rig speed, as determined from the tables below, may differ from the speedometer readings. Mark off a distance of 100, 200, and 300 feet in a field where the spraying is to be done - and run the tractor over this distance, carefully marking the throttle setting or speedometer reading. To make measurement of the test run, begin from standing start far enough ahead of first marker so that your rig is at full speed before traveling the 100, 200, or 300 foot distances.

TRACTOR SPEEDS

Speed in MPH (Miles Per Hour)	Time Required In SECONDS To Travel A Distance Of:		
	100 feet	200 feet	300 feet
3.0	23	45	68
3.5	20	39	58
4.0	17	34	51
4.5	15	30	45
5.0	14	27	41
6.0	-	23	34
7.0	-	19	29
7.5	-	18	27
8.0	-	17	26
9.0	-	15	23

Adjust The Spray Height To Give Proper Spray Overlap.

SUGGESTED MINIMUM SPRAY HEIGHT

Spray Angle	Spray Height	
	20" Spacing	30" Spacing
65°	21" to 23"	32" to 34"
73°	20" to 22"	27" to 29"
80°	17" to 19"	24" to 26"
110°	10" to 12"	14" to 18"

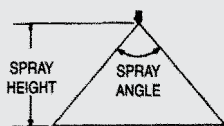

SPRAY COVERAGE INFORMATION

THEORETICAL SPRAY COVERAGE AT VARIOUS SPRAY HEIGHTS (AT 40 PSI)				
Spray Height	65° Spray Angle	73° Spray Angle	80° Spray Angle	150° Spray Angle
6"	7.6"	8.8"	10.1"	45"
9"	11.5"	13.3"	15.1"	67"
12"	15.3"	17.8"	20"	90"
15"	19.1"	22"	25"	112"
18"	23"	27"	30"	134"
21"	27"	31"	35"	157"
24"	31"	36"	40"	179"
27"	34"	40"	45"	202"
30"	38"	44"	50"	224"
33"	42"	49"	55"	246"
36"	46"	53"	60"	269"

AFTER SPRAYING

Rinse And Clean All The Spraying equipment - including the spray tips, being careful not to use a metal probe in the orifice. This cleaning routine is especially important after spraying wettable powders. Wash spray tips thoroughly with water or cleaning solution (appropriate for chemical sprayed). Blow out orifice clean and dry. If orifice remains clogged, clean it with a fine bristle (not wire) brush or with a toothpick. Do not damage the orifice. Water - rinse and dry tips before storing.

CAUTION:

AGRICULTURAL CHEMICALS CAN BE DANGEROUS. IMPROPER SELECTION OR USE CAN SERIOUSLY INJURE PERSONS, ANIMALS, PLANTS, SOIL, OR OTHER PROPERTY. BE SAFE: SELECT THE RIGHT CHEMICAL FOR THE JOB. HANDLE IT WITH CARE. FOLLOW THE INSTRUCTIONS ON THE CONTAINER LABEL AND INSTRUCTIONS FROM THE EQUIPMENT MANUFACTURER.

MISCELLANEOUS CONVERSION FACTORS

One Acre = 43,560 square feet = 0.405 Hectares.
 One Hectare = 2.471 Acres.
 One Gallon Per Acre = 9.35 Liters Per Hectare.
 One Mile = 5280 feet = 1610 Meters = 1.61 KM.
 One Gallon = 128 fluid ounces = 8 Pints = 4 Quarts
 One Gallon = 3.79 Liters = 0.83 Imperial Gallons
 One Pound Per Square Inch = 0.069 bar. = 6.896 Kilopascal
 One Mile Per Hour = 1.609 Kilometers Per Hour

ABBREVIATIONS

GPA - Gallons Per Acre
 GPM - Gallons Per Minute
 GPH - Gallons per Hour
 NPT - Tapered Pipe Thread
 MPH - Miles Per Hour
 PSI - Pounds per Square Inch (gauge pressure)

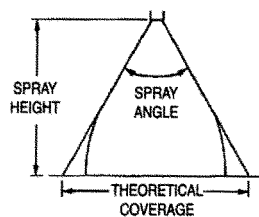

This table lists the theoretical coverage of spray patterns as calculated from the included spray angle of the spray and the distance from the nozzle orifice. These values are based on the assumption that the spray angle remains the same throughout entire spray distance. In actual practice, the tabulated spray angle does not hold for long spray distances.

PRO SERIES SPRAYERS
 UTILITY SPRAYERS
 SPOT SPRAYERS
 ATV SPRAYERS
 TRAILER SPRAYERS
 UTILITY & 3PT SPRAYERS
 SKID SPRAYERS & BOOMS
 PUMPS
 SPRAYER ACCESSORIES
 DRY MATERIAL SPREADERS
 TRAILER CARTS & AERATORS
 SPRAYER COMPONENTS
 PARTS LIST BREAKDOWNS

SPRAYING INFORMATION

SELECTION OF SPRAY TIP OR NOZZLE

To provide the variety of spray patterns and capacities used in farm spray applications, Spraying Systems Co. offers a complete line of nozzles and spray tips. Generally, standard flat spray TeeJet tips, with tapered pattern edges, mounted on a boom with overlapping spray patterns are used for applying herbicides and some insecticides. For band spraying applications requiring even spray distribution, the flat Even spray TeeJet tips are considered ideal. For spraying insecticides and fungicides hollow cone type ConeJet spray tips or disc core tips are used. This cone spray pattern provides better foliage coverage and is usually applied at higher pressures. For the surface application of liquid fertilizers, FloodJet tips and FloodJet nozzles - as well as boomless type FliedJet nozzles are usually recommended especially for suspension and slurry type fertilizers. In all cases follow the recommendations of the chemical manufacturers, Agricultural Extension Service and the USDA keeping driftage to a minimum.

USEFUL FORMULAS

$$\text{GPM (Per Nozzle)} = \frac{\text{GPA} \times \text{M.P.H.} \times \text{W}^*}{5940}$$

$$\text{GPA} = \frac{5940 \times \text{GPM (Per Nozzle)}}{\text{M.P.H.} \times \text{W}^*}$$

*W - Nozzle spacing (in boom spraying) or spray swath (in boomless) in inches.

SIZE SELECTION OF SPRAY TIP OR NOZZLE

Based on the chemical manufacturer's recommendations on GPA application rates and nozzle types, a suitable spray tip size is chosen from the catalog tabulations. Since all the tabulations are based on spraying water, which weighs 8.34 lbs. per USA gallon, conversion factors must be used when spraying solutions which are heavier or lighter than water. Using conversion factors from the tables below multiply by the catalog tabulated GPM and GPA rates - to arrive at the values for the solution to be sprayed.

Weight of solution	Specific Gravity	Conversion Factors
7.0 lbs. per gallon	.84	.92
8.0 lbs. per gallon	.96	.98
8.34 lbs. per gallon - WATER	1.00	1.00
9.0 lbs. per gallon	1.08	1.04
10.0 lbs. per gallon	1.20	1.10
10.65 lbs. per gallon - 28% nitrogen	1.28	1.13
11.0 lbs. per gallon	1.32	1.15
12.0 lbs. per gallon	1.44	1.20
14.0 lbs per gallon	1.68	1.30

NOZZLE SPACING

If the nozzle spacing on your boom is different than those tabulated, also multiply the tabulated or calculated GPA coverages by one of the following factors.

Where Tables Are Based on 20" Nozzle Spacing

Other Spacing	8"	10"	12"	14"	16"	18"	22"	24"	30"
Conversion Factor	2.5	2	1.67	1.43	1.25	1.11	.91	.83	.66

Where Tables Are Based on 30" Nozzle Spacing

Other Spacing	26"	28"	32"	34"	36"	38"	40"	42"	44"
Conversion Factor	1.15	1.07	.94	.88	.83	.79	.75	.71	.68

Where Tables Are Based on 40" Nozzle Spacing

Other Spacing	28"	30"	32"	34"	36"	38"	42"	44"	48"
Conversion Factor	1.43	1.33	1.25	1.18	1.11	1.05	.95	.91	.83

BEFORE YOU GO INTO THE FIELD

Check all your equipment - make certain that all components are clean including the tank, pump, control valves, check valves, hoses, boom, strainers, nozzles, and spray tips. **WARNING:** never use a metal object in cleaning nozzle orifices. Use a plastic or wooden probe.

Check the flow rate from all nozzles using a master pressure gauge mounted in the boom close to the nozzles. (After the test remove the master pressure gauge and plug the connection). While this nozzle flow test is being conducted, check the pressure reading on the rig pressure gauge to compare its reading to the pressure at the nozzles. The flow rates can be determined from the flow charts contained in this catalog. Remember, the catalog tabulations are based on pressures at the nozzles.

NOTE: If the ball type check valves are used, the actual nozzle pressure will be approximately 5 P.S.I. lower than the gauge reading, depending on spring rating and flow rate.

CHOICE AND CARE OF SPRAY EQUIPMENT

All the factors in today's spraying application, including chemical costs, pollution and driftage control, point to the importance of choosing the proper spray equipment and maintaining it in an efficient operating order. Therefore, the original purchased equipment should be made of materials which resist corrosion and wear such as stainless steel spray tips. Since usage of spray nozzles usually brings about orifice clogging problems, erosion, etc., it is very important that the tips be cleaned after each operation, and tested before using again. Finally even when using precision spray tips, it is necessary to control all the other factors in the spraying application - such as rig speed, spraying pressure, spray height, etc., in order to place the proper amount of chemicals in the proper areas. An established routine of proper maintenance will soon pay for itself.

WEIGHTS & MEASUREMENTS

Model #	Item #	UPC Code	UPS Weight	Shipping Weight	Carton L x W x H	# Of Units Per Pallets	Shipping Class	Cubic Feet
LG-4-3-1	5302314	733029109989	22#	20	14 x 11 x 23	42	150	2.1
LG-8-P	5302164	733029007841	45#	24#	19 x 17 x 23	18	150	4.3
LG-10-EC	5301547	733029005250	32#	14#	31 x 14 x 12	28	150	3.1
LG-15-EC	5301302	733029003058	46#	15#	34 x 16 x 14	24	150	4.5
LG-20-EC	5301548	733029005267	62#	17#	38 x 18 x 15	15	150	6
LG-25-EC	5301378	733029003195	74#	20#	40 x 19 x 16	15	150	7.1
LG-13-P	5300393	733029001009	46#	17#	34 x 16 x 14	24	150	4.5
LG-14-PM	5301144	733029002549	46#	17#	34 x 16 x 14	24	150	4.5
LG-14-SM	5301145	733029002556	46#	17#	34 x 16 x 14	24	150	4.5
LG-25-PM	5301146	733029002563	74#	23#	40 x 19 x 16	15	150	7.1
LG-25-PRO	5302922	733029116864	74#	23#	32 x 15 x 20		150	5.7
LG-25-SM	5301147	733029002570	74#	23#	40 x 19 x 16	15	150	7.1
LG-25-HV	5301222	733029002990	74#	24#	40 x 19 x 16	15	150	7.1
LG-28-S	5301063	733029002310	74#	22#	40 x 19 x 16	15	150	7.1
LG-29-P	5300632	733029001443	74#	22#	40 x 19 x 16	15	150	7.1
LG-40-DLX	5302186	733029107336	-	30#	30 x 20 x 24	12	150	8.4
LG-40-SS	5301335	733029003096	-	55#	40 x 26 x 25	6	150	15.1
LG-1500-303	5301064	733029002266	99#	49#	48 x 20 x 17	8	150	9.5
LG-2500-303	5301065	733029002273	109#	59#	50 x 20 x 18	8	150	10.5
TR-20-EX	5301549	733029005274	109#	51#	50 x 20 x 18	8	150	10.5
LG-20-TRL	5302316	733029110008	74#	54#	36 x 20 x 17	8	150	7.1
TR-30-EX	5301486	733029004703	115#	64#	50 x 20 x 19	8	150	11
LG-30-TRL	5302317	733029110015	109#	65#	45 x 20 x 20	8	150	11
TR-40-EX	5301338	733029003126	-	*205#	65 x 26 x 31	2	150	30.4
TR-40-GAS	5301339	733029003133	-	*230#	65 x 26 x 31	2	150	30.4
LG-50-TRL-PRO	5302928	733029117441			55 x 41 x 28		150	36.6
ATVTS-60-12V	5301192	733029002686	-	*295#	74 x 35 x 30	2	150	45
ATVTS-60-12V-BL	5301305	733029003249	-	*269#	74 x 35 x 30	2	150	45
SK-61-12V	5301304	733029003225	-	*180#	65 x 26 x 31	2	150	30.4
SK-61-4R	5301336	733029003102	-	*205#	65 x 26 x 31	2	150	30.4
SK-110-8R	5301052	733029004260	-	*279#	79 x 41 x 49	1	150	91.9
9-150	5300431	733029001214	-	*314#	79 x 41 x 49	1	150	91.9
TSSK-60	5301161	733029002587	-	*215#	65 x 26 x 31	2	150	30.4
LSS-280	5300467	733029001139	-	*446#	79 x 41 x 49	1	150	91.9
TSSK-300	5301337	733029003164	-	*636#	-	1	250	
ATV-15-2QR	5302318	733029110022	74#	27#	40 x 19 x 16	15	150	7.1
ATV-20-2QR	5302319	733029110039	74#	28#	40 x 19 x 16	10	150	7.1
ATV-25-700-PRO	5302927	73302911734			56 x 15 x 26		150	12.7
ATV-25-700-QR	5302320	733029110046	142#	63#	56 x 20 x 21	8	150	13.7
ATV-25-71-QR	5302321	733029110053	142#	68#	56 x 20 x 21	8	150	13.7
LG-3025-PRO	5302926	733029117427			38 x 15 x 20		150	6.6
LG-3025-QR	5302322	733029110060	62#	35#	38 x 18 x 15	10	150	6
UTL-40-5	5301399	733029003355	-	*167#	44 x 44 x 36	3	150	40.4
UTL-40-12V	5301343	733029003379	-	*164#	44 x 44 x 36	3	150	40.4
UTL-40-12V-BL	5301344	733029003386	-	*158#	44 x 44 x 30	3	150	33.7
UTL-60-7	5301400	733029003362	-	*185#	44 x 44 x 36	3	150	40.4
UTL-60-12V	5301347	733029003416	-	*173#	44 x 44 x 36	3	150	40.4
UTL-60-12V-BL	5301348	733029003423	-	*166#	44 x 44 x 30	3	150	33.7
UTV-45-7	5302864	733029114839	-	*130#	37 x 31 x 19	4	150	12.7
UTV-45-BL	5302865	733029114822	-	*125#	37 x 31 x 19	4	150	12.7
UTV-65-7	5302830	733029114433	-	*135#	47 x 36 x 18	4	150	17.7
UTV-65-BL	5302843	733029114327	-	*130#	47 x 36 x 18	4	150	17.7
LG-40-3PT-12V	5302032	733029010513	139#	*90#	40 x 24 x 24	6	150	13.4
LG-40-3PT-PRO	5302929	733029117458	139#	*90#	40 x 24 x 24	6	150	13.4
LG-55-3PT	5300576	733029001146	-	*180#	43 x 34 x 42	2	150	45
LG-60-3PT	5301160	733029002617	-	*265#	45 x 41 x 40	2	150	43
110 3PT	5300438	733029001573	-	*388#	50 x 45 x 84	1	150	109.4
200 3PT	5300758	733029001580	-	*511#	90 x 48 x 53	1	150	132.6
300 3PT	5300653	733029001597	-	*606#	90 x 48 x 53	1	150	132.6
257-8	5300658	733029004710	-	*174#	94 x 27 x 10	5	85	14.7
TC-10-P	5301461	733029003614	149#	75#	49 x 36 x 14	7	85	14.3
TC-10-18	5301546	733029005243	127#	103#	44 x 34 x 14	7	85	12.2
TC-17	5301397	733029003331	-	*250#	61 x 39 x 17	5	85	23.4
TC-17-4	5301398	733029003348	-	*277#	61 x 39 x 17	4	85	23.4
ATV-DMS-12V	5301845	733029008633	81#	69#	29 x 21 x 22	9	85	7.8

***** Commercial and Residential Shipping Rates Vary *****

* Includes 50# for pallet

THANK YOU

We at Fimco Industries want to express our appreciation for the business you have given us. We are committed to building high quality sprayers and providing a combination of high caliber product lines, knowledgeable sales staff and prompt service all at competitive prices. We will continue to do our very best to provide the same high standards of product and service you have come to expect from us.

LIMITED WARRANTY

All warranties are subject to the warranty of the original manufacturer. Fimco Industries' products are warranted for one year from date of purchase against material or workmanship defects for personal or homeowner usage. Fimco Industries products are warranted for 90 days for commercial users. Any unauthorized modification of a Fimco product will void the warranty. Warranty claims will be processed by Fimco Industries after the items are returned freight prepaid to the Fimco Industries location where the product was purchased. Examination and determination of warranty, if applicable, will be subject to and limited by the warranty of the original manufacturer. Fimco Industries assumes no liability for any unwarranted equipment. All items must be returned within 30 days of failure.

LIQUID CARRYING VESSEL WARRANTY

Liquid carrying vessels are subject to the applicable warranty only. The loss of chemicals within the vessel is not covered by warranty. Expenses, inconveniences or other damages that may occur are not subject to warranty consideration. The warranty is void if the vessel or vessel lining failed because of inadequate support of the vessel, misuse or lack of reasonable care or use of chemical formulations not recommended by the vessel manufacturer. The user shall check all labels for the information on known chemicals that are detrimental to vessel or vessel lining. The user shall determine the suitability of the product for his intended use and assume all risks and liability in connection therewith. The entire limited warranty is embodied in this writing. Fimco Industries neither assumes nor authorizes any person to assume for it any other liability in connection with its equipment.

RETURN FOR CREDIT

Merchandise may be returned for credit only upon authorization by Fimco Industries. Upon authorization, merchandise must be returned freight prepaid within 30 days of purchase. All returns must specify the invoice number and the date the items were purchased. Credit will be issued for the net invoice cost less all allowances, freight charges, a handling charge and additional charges for any items not received in saleable condition. Special orders cannot be returned. The final credit issued, in any event, will be subject to Fimco Industries inspection to determine condition.

CHECK MERCHANDISE IMMEDIATELY UPON RECEIPT

If a shipment is received in bad condition or there is a shortage, note this fact on the carriers receipt. Report any problems to Fimco Industries immediately.

PRICES

Prices shown are FOB Fimco Industries or FOB manufacturer and are current to the best of our knowledge. However, prices may change at any time without notice or obligation as some of our suppliers implement price changes throughout the year. Prices charged will be the current pricing at the time of shipment. If you have any questions, please contact us at Fimco Industries.



PRO SERIES
SPRAYERS
UTV
SPRAYERS
SPOT
SPRAYERS
ATV
SPRAYERS
TRAILER
SPRAYERS
UTILITY &
3PT
SPRAYERS
SKID
SPRAYERS
&
BOOMS
PUMPS
SPRAYER
ACCESSORIES
DRY
MATERIAL
SPREADERS
TRAILER
CARTS
&
AERATORS
SPRAYER
COMPONENTS
PARTS/LIST
BREAKDOWNS

INDEX

A			
Ace Pumps.....	107-108	Hypro Roller Pump	105-106
Accessories for Gauges.....	119	Hypro Roller Pump Repairs.....	105-106
Accessories, Pump.....	77, 105-106	K	
Accessories, Tank.....	1, 99, 155	Kit, Gauge Isolator.....	119
Agitators, Tank.....	155	Kits, Hand Gun.....	67, 77
ATV Sprayer Comparison.....	28-29	Kits, Pump Repair (Roller Pump).....	105-106
ATV Mounted Sprayers.....	6-7, 31-35	L	
B		Lawn Attachments.....	90-97
Bodies, Nozzle.....	115, 128-129, 132	Lawn Rollers.....	89
Boom Assemblies.....	64-66, 77, 82-83	Line Strainers.....	123-124
Boomless Nozzles.....	78-81, 83, 142, 144	M	
C		Manifolds.....	121
Calibration Container.....	145	Multifunction Sprayer.....	25
Caps, Nozzle.....	78-80, 116, 130-131, 133	Multi-Lid.....	1, 4
Centrifugal Pumps.....	107-109	N	
Color Coded Tips.....	135-140, 142	Nozzle Components.....	128-133
Couplers, Pump & PTO.....	105-106	Nozzles.....	133-144
D		Nylon Quick Couplers for Hoses.....	116
Diaphragm Check Valve Nozzles.....	129-130, 132	Nylon Fittings.....	111-114
Diaphragm Pumps, Hypro.....	110	Nylon Hose Inserts.....	115-116
Drop Pipes & Swivels.....	154	P	
Dry Material Spreader, ATV.....	84-85	Packaged Parts.....	78-81
Dry Material Spreader, ATV Pull Behind.....	86-87	Pasture Blaster.....	47
Dry Material Spreader, 3 Point Hitch.....	88	Poly Hose Couplers (Banjo Camlever).....	117
Dry Material Spreader, Truck Hitch.....	85	Polypropylene Hose Inserts.....	115-116
E		Polypropylene Fittings.....	111-114
Electric Diaphragm Pump (12 Volt).....	68-76	Polypropylene Quick Couplers for Hose.....	117
Electric Valves.....	110, 125-126	Polypropylene Spray Guns.....	149, 152
Electric Sprayer Controls.....	125	Polyethylene Tanks.....	98-102
EPDM, EVA and PVC Sprayer Hoses.....	118	Pre-emergence Tips.....	134, 139
F		Pressure Relief Valves.....	121-122
Fire Fighting Units.....	60-61	Pro Series Sprayer Comparison.....	2-3
Fitting Nylon, Pipe.....	111-114	Pro Series Spot Sprayer.....	5
Foam For Marker.....	98	Pro Series ATV Sprayers.....	6-7
Foam Marker.....	98	Pro Series 3PT Sprayer.....	8
G		Pro Series Trailer Sprayers.....	9
Gasoline Engine Driven Pumps.....	67, 110	Pump Accessories.....	105-106
Gasoline Engine Skid Sprayers.....	59-62	Pump Repair Kits.....	70-73, 75-76, 105-106
Gauge Isolator Kit.....	119	Pumps.....	68-76, 105-106, 107-110
Gauges.....	119	Pumps, Gasoline Engine Driven.....	67
Gauges Accessories.....	119	R	
H		Remote Control Kit (Remote Switch).....	1
Hand Guns & Parts.....	78-80, 146-154	Roller, Lawn.....	89
Hand Gun Kits.....	67, 77	Row Crop Sprayers.....	53-55
Hand Gun, Lithium Ion Powered.....	27	S	
Hitch (3 Point) Sprayers.....	49-55	Saddles & Straps for Polyethylene Tanks.....	53-55, 99
Hose Assemblies.....	118	Screen, Nozzle.....	130
Hose Barbs.....	71, 73, 113-116	Selector Valves, Boom.....	125-127
Hose Clamps.....	118	Shipping Information.....	175
Hose & Pipe Cutter.....	118	Shut Off Valves.....	120-121
Hose Reels.....	63	Skid Sprayers (Lawn & Garden).....	58-59
Hose for Sprayer.....	118	Skid Mounted Sprayers (Ag.).....	60-62
Hydraulic Lift Kit.....	67	Skid Mounted Commercial Sprayers.....	60-62
Hypro Diaphragm Pump & Kits.....	110	Spot Sprayer Comparison.....	14-15
Hypro Centrifugal Pumps.....	109	Spot Sprayers.....	5, 16-23, 25-26
		Spray Guns.....	146-153
		Spray Nozzle Parts.....	130
		Spray Tips, Off-Center.....	145
		Sprayer Controls.....	125
		Sprayer Hoses.....	118
		Sprayer Selector Valves.....	126-127
		Spraying Information.....	173-174
		Strainer, Line.....	123-124
		Swivels, Connector.....	131, 154
		T	
		Tanks.....	98-102
		Tank Accessories.....	1, 99, 155
		Tank Cleaning Agent.....	1, 24
		Tank Repair Parts.....	156
		TeeJet Tips.....	134-145
		Terms & Conditions.....	176
		Three Point Hitch Sprayer Comparison.....	48
		Three Point Hitch Sprayers.....	8, 49-55
		Tips, Nozzles.....	133-145
		Trailer Carts.....	93-97
		Trailer Kits Lawn & Garden.....	77
		Trailer Sprayer Comparison Lawn & Garden.....	36-37
		Trailer Type Sprayers Lawn & Garden.....	9, 39-47
		U	
		Utility Lawn & Garden Sprayers.....	56
		UTV Sprayer Comparison.....	10
		UTV Sprayer.....	11-13
		V	
		Valves, Boom.....	125-127
		Valve, Diaphragm Check (for Nozzles).....	129-130, 132
		Valve, Electric.....	125-126
		Valve, Pressure Relief.....	121-122
		Valves, Shut-Off.....	120-121
		Vari-Spacing Nozzles.....	128-129
		W	
		Wand, High Pressure.....	148, 153
		Weights & Measurements.....	175
		Wheeled Spot Sprayer Comparison.....	24
		Wheeled Spot Sprayers.....	25-26
		REPAIR PARTS LIST FOR SPRAYERS	
		ATV-15-2-QR.....	159
		ATV-25-71-QR.....	160
		ATVTS-60-12V.....	165
		Boom Assemblies.....	170-172
		LG-15-EC.....	157
		LG-25-EC.....	157
		LG-14-PM.....	158
		LG-14-SM.....	158
		LG-25-PM.....	158
		LG-25-SM.....	158
		LG-1500-303.....	162
		LG-2500-303.....	162
		LG-20-TRL.....	163
		LG-30-TRL.....	163
		LG-3025-QR.....	161
		LG-40-3PT-12V.....	166
		LG-60-3PT.....	167
		TR-40-EX.....	164
		UTV Boomless Units.....	168
		UTV 7-Nozzle Units.....	169



**PRO PUMP. PRO HANDGUN.
PROFESSIONAL GRADE SPRAYER.**



2018 CATALOG &
PARTS BOOK

NORTH SIOUX CITY, SD • 1000 FIMCO LN 57049

PHONE: 605.232.6800 • FAX: 605.232.6814

TOLL FREE: 800.831.0027 • TOLL FREE FAX: 800.494.0440

WWW.FIMCOINDUSTRIES.COM • INFO@FIMCOINDUSTRIES.COM